

(19) **DANMARK**

(10) **DK/EP 3208088 T3**



(12)

Oversættelse af europæisk patentskrift

Patent- og
Varemærkestyrelsen

-
- (51) Int.Cl.: **B 41 F 16/00 (2006.01)** **B 41 F 19/02 (2006.01)**
- (45) Oversættelsen bekendtgjort den: **2019-03-11**
- (80) Dato for Den Europæiske Patentmyndigheds bekendtgørelse om meddelelse af patentet: **2019-01-02**
- (86) Europæisk ansøgning nr.: **17152360.8**
- (86) Europæisk indleveringsdag: **2017-01-20**
- (87) Den europæiske ansøgnings publiceringsdag: **2017-08-23**
- (30) Prioritet: **2016-02-18 DE 102016202476**
- (84) Designerede stater: **AL AT BE BG CH CY CZ DE DK EE ES FI FR GB GR HR HU IE IS IT LI LT LU LV MC MK MT NL NO PL PT RO RS SE SI SK SM TR**
- (73) Patenthaver: **Heidelberger Druckmaschinen AG, Kurfürsten-Anlage 52-60, 69115 Heidelberg, Tyskland**
- (72) Opfinder: **Schadl, Hans, Weiher 37, 92242 Hirschau, Tyskland**
- (74) Fuldmægtig i Danmark: **Plougmann Vingtoft A/S, Strandvejen 70, 2900 Hellerup, Danmark**
- (54) Benævnelse: **APPARAT TIL VARMFOLIEPRÆGNING**
- (56) Fremdragne publikationer:
EP-A1- 2 886 360
DE-A1- 2 556 414
DE-A1-102015 212 279

Description

5 The invention relates to a device for hot-foil stamping according to the preamble of claim 1.

Prior art

So-called hot-foil stamping belongs inter alia to the well-known sorts of finishing in the printing industry.

10 Mirror-finished planar elements in gold, silver, copper, aluminium and other metallic colours can be transferred in a hot-foil stamping printing procedure onto the print substrate. A carrier film is coated with the colouring layer and a heat-meltable adhesive (adhesive layer). Under the action of pressure and heat, the picture can be transferred with a heated stereotype (letterpress plate). Suitable machines are either rotative
15 processing stations in printing machines or flatbed punch and/or stamping machines. The hot-foil stamping is used primarily in a wide assortment of sheet and roll products, such as packings for cosmetics, confectionary and beverages and for high-quality brochures.

In DE 10 2009 019 590 A1 is described a rotative hot-foil stamping station, which is shown in its figure 8. Document EP-A-2 886 360 discloses a device according to the
20 preamble of claim 1.

Disadvantageous in devices of this sort for hot-foil stamping is the high cost and time expenditure involved in the manufacture of the tools, that is the stereotypes for a respective order.

25 Task definition

Task of the present invention, therefore, is the creation of a device for hot-foil stamping which does not have the disadvantages of the prior art and facilitates a hot-foil stamping in only one processing station without expensive stamping tools individual to each order.

30 This task is solved with a device for hot-foil stamping with the characteristics of claim 1. The device according to the invention for hot-foil stamping on print substrates, such as sheets or webs, in particular made of paper, cardboard or plastic, includes a stamping element, a counter-pressure element assigned to this stamping element and a

device for providing stamping foil. According to the invention, the device includes a laser unit for partially heating stamping foil in the region of the stamping elements, wherein the stamping element is formed transparent such that the laser beams of the laser unit penetrate through the stamping element and the stamping foil is partially heated at the
5 desired points. The advantage of this device is that no tools need to be created specifically for the order. In this way, it is possible within a very short time to change the pattern of the hot-foil stamping. This means that a motive can also be altered during on-going production. By means of the direct heating of the stamping foil it is ensured that the hot-foil stamped motive has a high degree of contour sharpness.

10 The device according to the invention includes a control unit at least for actuating the laser unit. Additionally, a sensor having a data communication link with the control unit is provided to monitor the print substrate such that a precise controlling of the laser unit can be achieved. In this way, the hot-foil stamping can be applied precisely to a printed picture which has already been printed on the print substrate.

15 In an advantageous further development of the device according to the invention, the stamping element is made of glass. The counter-pressure element can have a rubber-coated surface.

In a first embodiment variation, stamping element and counter-pressure element are designed respectively as cylinders, in a second embodiment variation, stamping
20 element and counter-pressure element are designed respectively as plates.

In the first embodiment variation, a cooling device can be provided adjacent to the stamping cylinder.

The described invention and the described advantageous further developments of the invention constitute also in combination with one another - inasmuch as this is
25 technically sensible - advantageous further developments of the invention.

With respect to further advantages and developments of the invention advantageous in constructional and functional respect, reference is made to the sub-claims and the description of embodiment examples with reference to the accompanying
30 figures.

Embodiment example

The invention is to be described in still more detail with reference to attached figures. Elements and components corresponding to one another are labelled in the

figures with the same reference signs. In order to achieve an improved visibility of the figures, no true-to-scale representation has been made. In schematic representation:

figure 1 shows a first embodiment variation of a device according to the invention for hot-foil stamping

5 figure 2 shows a second embodiment variation of a device according to the invention for hot-foil stamping

figure 3 shows a printing machine in an overview representation.

Figure 3 shows as an example of a processing machine 100 a rotary printing machine for printing a substrate web 1. The substrate web 1 is here transported in transport direction T through a plurality of processing facilities and hereby processed. The processing facilities are conventional printing facilities 11, a digital printing facility 14, a stamping facility 12 and a punching and scoring facility 13. Adjacent to the web run of the substrate web 1, one (or also several) inspection system 4 can be provided which is for example in the form of a camera, in order to monitor continuously the substrate web 1.

15 Instead of the conventional embossing facility 12, a device for hot-foil stamping 10, such as described hereinafter, can come into use.

Especially advantageous is the use of a device of this sort for hot-foil stamping 10 in processing machines 100 which have exclusively digital processing stations.

Figure 1 shows a first embodiment variation of the device for hot-foil stamping 10 which provides cylinders as processing tools: the device 10 includes a transparent cylinder 21 and a counter-pressure cylinder 16. The counter-pressure cylinder 16 can here be rubber coated. Through the pressure gap between the transparent cylinder 21, for example in the form of a glass cylinder, and the counter-pressure cylinder 16, both a substrate web 1 and a foil 2 are guided. Provision and guiding of the film web 2 are carried out by a device, not shown in more detail, having transport rollers for providing stamping foil. Within the transparent cylinder 21 is disposed a laser unit 19 which is controlled by a control unit 3 (not shown here). The laser beams 20 emitted by the laser unit 19 penetrate the transparent cylinder 21 and heat in a targeted and local manner the foil 2. At this locally heated point, metal particles can then be transferred from the carrier foil 2 onto the substrate web 1 and are "ironed-on" to the substrate web 1 by reason of the pressing force F between transparent cylinder 21 and counter-pressure cylinder 16, which results in the generation of the hot-foil stamping.

In figure 2 is shown an alternative embodiment form of the device for hot-foil stamping 10. Instead of the cylinder, here plates are used, specifically a transparent plate 22 as stamping element, which can be in the form of a glass plate, and a counter-pressure plate 23 as counter-pressure element. Also here, the counter-pressure plate 23 can have a rubber coated surface.

While the variation equipped with cylinders 16, 19 according to figure 1 facilitates a continuous processing of a print substrate 1, with the embodiment variation according to figure 2 having the plates 22, 23, only a discontinuous processing of the print substrate 1 can be achieved. This means, for each stamping procedure, the print substrate 1 must be stopped for a short time.

List of reference signs

	1	substrate web (print substrate)
	2	foil
5	3	control unit (machine controlling with interface)
	4	inspection system
	10	device for hot-foil stamping
	11	printing facility
10	12	stamping facility
	13	punching and scoring facility
	14	digital printing facility
	15	print cylinder
	16	counter-pressure cylinder
15	17	stamping cylinder
	18	punching cylinder
	19	laser unit
	20	laser beam
	21	transparent cylinder (glass cylinder)
20	22	transparent plate (glass plate)
	23	counter-pressure plate
	24	cooling device
	100	printing machine
25	F	pressing force
	T	web transport direction

Patentkrav

1. Apparat (10) til varmfolieprägning på ark eller baner (1), på hvilke der
5 allerede er trykt et billede, med et prægeelement (21, 22), et
kontraprægeelement (16, 23) og en indretning til tilvejebringelse af prægefolie
(2),
idet apparatet har en lasereinheit (19) til partiel opvarmning af prægefolie (2) i
prægeelementets område (21, 22), og
10 idet prægeelementet (21, 22) udformet transparent,
kendetegnet ved,
at apparatet har en styreenhed (3) i det mindste til styring af laserenheden (19),
og
at apparatet har en med styreenheden (3) dataoverføringsteknisk forbunden
15 sensor (4) til overvågning af arkene eller banerne (1) og til styring af
laserenheden (19) i register, således at varmfolieprägningen påføres på arkene
eller banerne (1) i register med det allerede i forvejen påtrykte billede.
2. Apparat til varmfolieprägning ifølge krav 1,
20 **kendetegnet ved,**
at prægeelementet (21, 22) er af glas.
3. Apparat til varmfolieprägning ifølge et af de foregående krav,
kendetegnet ved,
25 **at** kontraprægeelementet (16, 23) har en gummieret overflade.
4. Apparat til varmfolieprägning ifølge et af de foregående krav,
kendetegnet ved,
at prægeelementet (21) og kontraprægeelementet (16) hvert især er udformet
30 som cylinder.
5. Apparat til varmfolieprägning ifølge krav 4,
kendetegnet ved,
at en køleindretning er anbragt stødende op til prægecylinderen (21).

6. Apparat til varmfolieprägning ifølge et af kravene 1 til 3,
kendetegnet ved,

at prægeelementet (22) og kontraprægeelementet (23) hvert især er udformet som plade.

5

7. Trykmaskine (100) med mindst et trykværk (11) og nedstrøms for dette med et apparat (10) ifølge et af de foregående krav.

8. Trykmaskine (100) ifølge krav 7 udformet som digital trykmaskine.

10

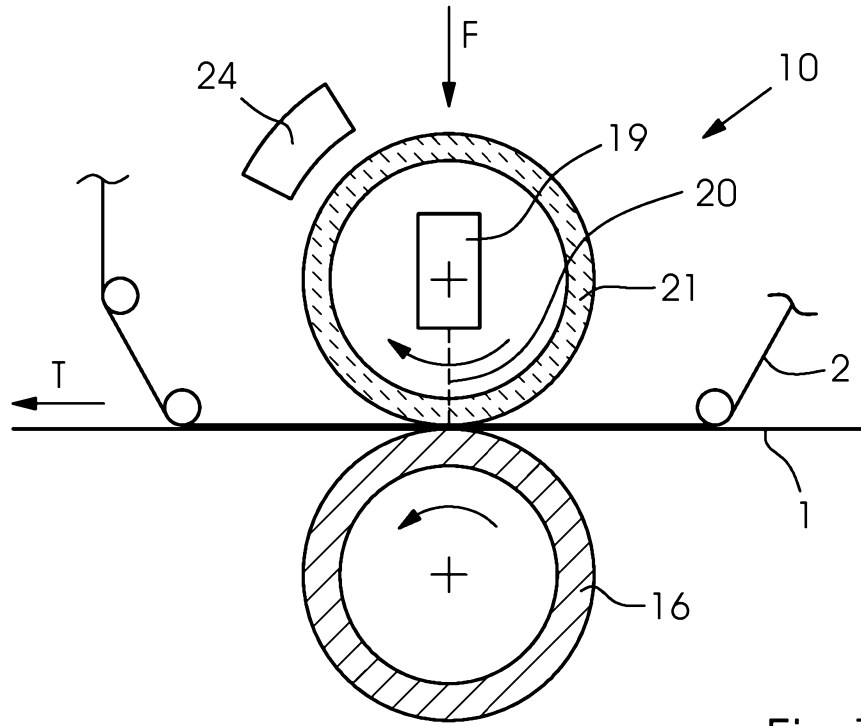

Fig. 1

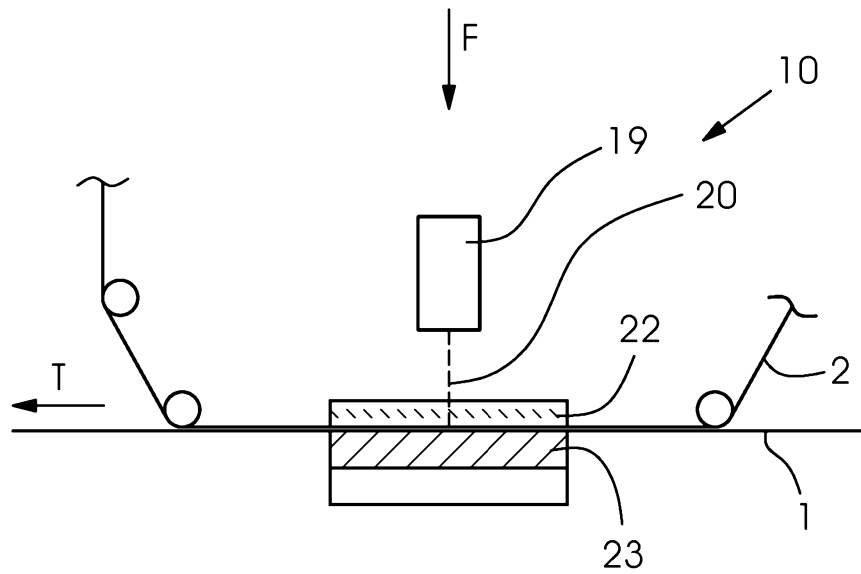

Fig. 2

