

(No Model.)

J. H. HEBBLETHWAITE.  
NUT LOCK.

No. 522,661.

Patented July 10, 1894.

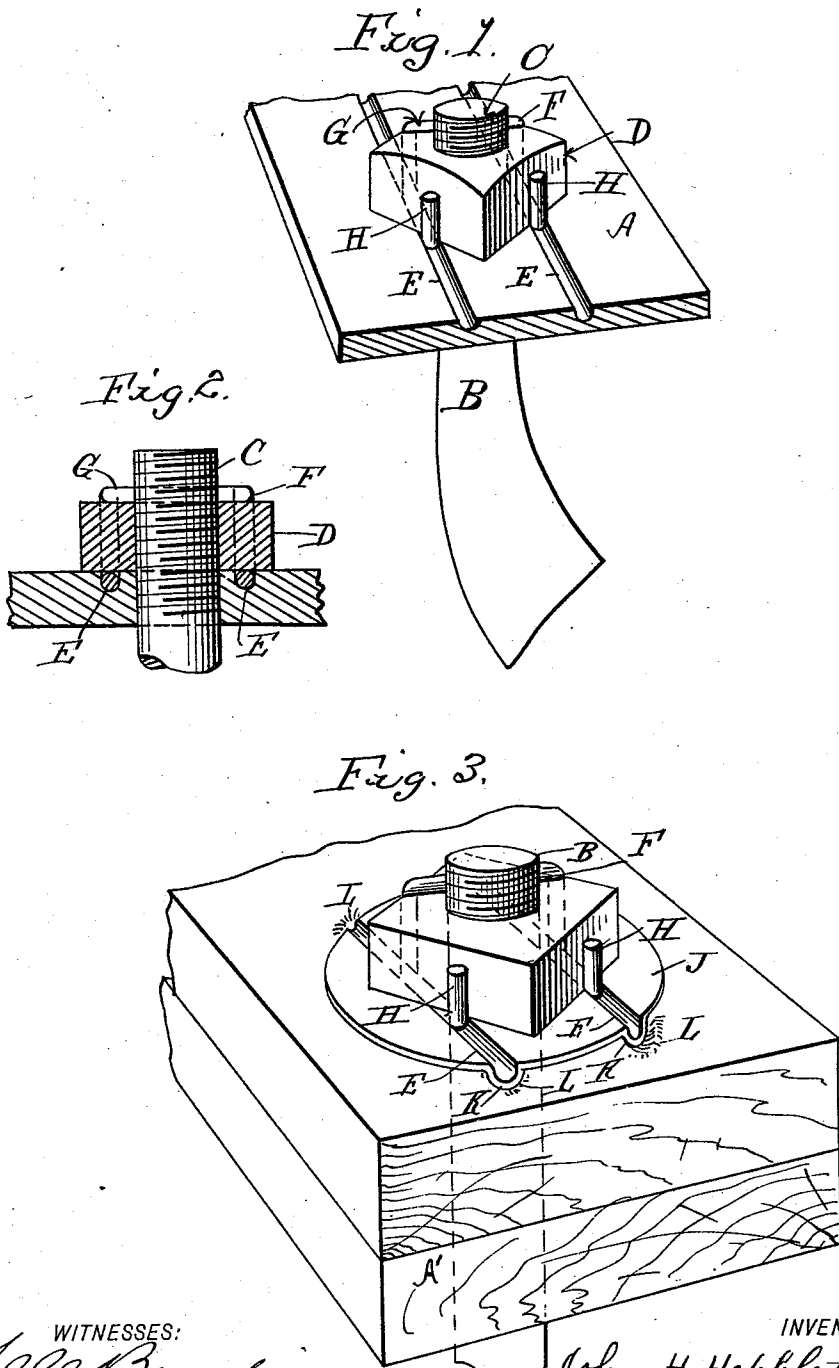

WITNESSES:  
*W. B. Bull*  
*C. B. Bull*

INVENTOR  
*John H. Hebblethwaite.*  
BY  
*John G. Marchant*  
His ATTORNEY.

# UNITED STATES PATENT OFFICE.

JOHN H. HEBBLETHWAITE, OF ROCK FALLS, ILLINOIS, ASSIGNOR OF ONE-HALF TO JOSEPH WRIGHT, OF SAME PLACE.

## NUT-LOCK.

SPECIFICATION forming part of Letters Patent No. 522,661, dated July 10, 1894.

Application filed January 9, 1894. Serial No. 496,242. (No model.)

*To all whom it may concern:*

Be it known that I, JOHN H. HEBBLETHWAITE, a citizen of the United States, residing at Rock Falls, in the county of Whiteside and State of Illinois, have invented certain new and useful Improvements in Nut-Locks; and I do declare the following to be a full, clear, and exact description of the invention, such as will enable others skilled in the art to which it appertains to make and use the same, reference being had to the accompanying drawings, and to letters of reference marked thereon, which form a part of this specification.

My invention has reference to improvements in nut-locks, and contemplates a mode of permanently and securely preventing the untwisting or loosening of the nut upon threaded bolts in every situation and locality in which the latter are utilized.

It is well known that threaded and nuted bolts are used in innumerable and variant conditions, in many of which the absolute fixity of the nut upon the bolt is very essential, in fact frequently vital, not only to the operation of the machinery, but to the safety of the latter as well. Further, the situation is frequently such that it is impracticable to keep constant watch in the premises, so that reliance must be necessarily had upon the inherent stability of the nut. In many situations where threaded bolts are used there is more or less jar of the parts, which has a tendency to loosen the nut, however firmly the latter may have been tightened. This general necessity for an assured permanency in the seating of the nut has led to the originating of various forms of nut-locks, some of which doubtless are efficient, so far as securing the nut is concerned; but are objectionable either in the expense of applying the device, or in the inconvenience or loss in the necessary removals of the nut.

In my invention I obviate these objections by providing a simple, cheap and efficient, mode of permanently locking the nut, which can be easily put in operation, and offers no serious obstacle to the removal of the nut, and is further adapted to be replaced with very trifling expense.

The situations in which nuts are usually

seated upon bolts are of two general characters,—one, in which the nut is seated against an iron surface; the other, in which the bolt is projected through wood, and the nut seated against the latter. I will, therefore show the application of my invention in both of said situations.

I attain the above result by the mechanism illustrated in the accompanying drawings, in which—

Figure 1 is a perspective of a cylinder tooth of the usual thrashing machine, seated by means of my invention. Fig. 2 is a vertical cross-section of the same. Fig. 3 is a perspective of my invention, as applied to mutually attaching two pieces of wood or of wood and metal, the wood or wooden member being that against which the nut is seated.

Similar letters refer to similar parts throughout the several views.

Referring to Fig. 1, as illustrating one method of the application of my invention, A is the usual metallic transverse bar, of either the cylinder or concave of an ordinary thrashing machine.

B is a tooth seated therein by being projected through said bar, and provided with the usual threads upon its shank or projected end C.

D is the usual angled nut seated on the threaded portion C against the bar A, oppositely to the main portion of the tooth B.

In the surface of the bar A, adjacent to the nut D, are formed two substantially parallel grooves E—E, of sufficient size to receive the wire intended to be employed.

F is a wire loop normally of staple formation, having its respective limbs placed in the grooves E. The nut D is then screwed down on the threaded shank C into place against the adjacent side of the bar A, in which condition the wire F will lie in the grooves E interposed between said nut and bar. After the nut is driven into its desired position, the loop end G of the wire F is by any suitable means turned over the adjacent angle of said nut, in position to embrace such angle of the latter. The opposite ends H of the wire F are then severally turned up against said nut on the respective sides of an opposite angle of the latter. In this position the walls or

sides of the nut are not only held at four different localities, but what is more important, the projection of the wire above the grooves at the base of the nut, and at four different localities, interposes a wedge-like resistance against the rotation of the nut in either direction. This compound lock, at the four several points of contact of said nut with the plate A, precludes any undue pressure of the nut against the bent-up portions of said wire, and to that extent prevents any casual straightening of said wire. The grooves E can be readily formed in the face of the bar A by either stamping or planing them therein.

Referring to Fig. 3, A represents a wooden bar adapted to be attached to a secondary bar A' of either metal or wood.

B is an ordinary bolt, having the usual head at one end, and a threaded shank C at the other.

J is a washer, provided with the same parallel grooves E—E shown in Figs. 1 and 2. In the formation of the grooves E—E in the washer J, corrugations or ribs K are formed on the opposite sides of said washer, so that when the nut D is seated, as aforesaid, the compression forces the ribs K slightly into the adjacent surface of the wood A, causing depressions L therein and thereby preventing the rotation of said washer, so long as the latter is held firmly against the adjacent surface of A.

The residue of the parts and their construction and operation are the same as heretofore described in reference to the seating of the nut upon a metallic base.

The wire F may, if preferred, be made in sections, in which event it would normally consist of two straight members. It may be that one of said wires would be sufficient, but inasmuch as too much security cannot be attained, I think the double lock shown is preferable. Should there be occasion for a removal and replacing of the nut, the bent extremities of the wire F are turned down to permit the rotation of the nut, and either replaced in the subsequent seating of the nut, or new wires used.

The advantage of my invention consists in the fact that it can be very easily applied, and that it insures absolute permanency in the seating of the nut, and as it occupies no greater space than that taken by the nut and the bolt shank, it is susceptible of adaptation in every conceivable locality in which a nutted and threaded bolt is employed.

What I claim as my invention, and desire to secure by Letters Patent of the United States, is—

1. A nut-lock comprising a seat provided with grooves, a bolt fitting in said seat, a nut upon said bolt and seated in part over said grooves, and a staple the legs of which rest in the grooves, the closed end of said staple being bent up and passing over said nut, the free ends of said staple being also bent out of line to hold the nut in place; substantially as described.

2. A nut-lock comprising a seat, a bolt fitting therein, a plate provided with grooves fitting over the bolt so that the said bolt projects between the grooves, a nut upon said bolt and seated in part over said grooves, a staple the legs of which rest in said grooves, the closed end of said staple being bent up and passing over said nut, the free ends of said staple being also bent out of line to hold the nut in place, and means for securing the plate upon the seat against rotation; substantially as described.

3. In a nut lock, the combination of the bar A provided with indentations L, bolt B seated in said bar, washer J provided with groove or grooves E and with rib or ribs K, nut D seated in part over said grooves, and wire F interposed between said nut and washer in groove E and slightly bent over the adjacent angle of said nut; substantially as described.

In testimony whereof I affix my signature in presence of two witnesses.

JOHN H. HEBBLETHWAITE.

Witnesses:

JOHN G. MANAHAN,  
JOSEPH WRIGHT.