

(19) World Intellectual Property Organization  
International Bureau



(43) International Publication Date  
11 June 2009 (11.06.2009)

PCT

(10) International Publication Number  
**WO 2009/071956 A2**

(51) International Patent Classification: Not classified

(21) International Application Number:  
PCT/HU2008/000043

(22) International Filing Date: 7 May 2008 (07.05.2008)

(25) Filing Language: English

(26) Publication Language: English

(30) Priority Data:  
P0700773 3 December 2007 (03.12.2007) HU

(71) Applicant and

(72) Inventor: **TÓTH, Miklós** [HU/HU]; Petöfi u. 50., H-3555 Harsány (HU).

(74) Agent: **PINTZ, György**; Georg Pintz & Partners, Pf. 590, H-1539 Budapest (HU).

AO, AT, AU, AZ, BA, BB, BG, BH, BR, BW, BY, BZ, CA, CH, CN, CO, CR, CU, CZ, DE, DK, DM, DO, DZ, EC, EE, EG, ES, FI, GB, GD, GE, GH, GM, GT, HN, HR, HU, ID, IL, IN, IS, JP, KE, KG, KM, KN, KP, KR, KZ, LA, LC, LK, LR, LS, LT, LU, LY, MA, MD, ME, MG, MK, MN, MW, MX, MY, MZ, NA, NG, NI, NO, NZ, OM, PG, PH, PL, PT, RO, RS, RU, SC, SD, SE, SG, SK, SL, SM, SV, SY, TJ, TM, TN, TR, TT, TZ, UA, UG, US, UZ, VC, VN, ZA, ZM, ZW.

(84) Designated States (unless otherwise indicated, for every kind of regional protection available): ARIPO (BW, GH, GM, KE, LS, MW, MZ, NA, SD, SL, SZ, TZ, UG, ZM, ZW), Eurasian (AM, AZ, BY, KG, KZ, MD, RU, TJ, TM), European (AT, BE, BG, CH, CY, CZ, DE, DK, EE, ES, FI, FR, GB, GR, HR, HU, IE, IS, IT, LT, LU, LV, MC, MT, NL, NO, PL, PT, RO, SE, SI, SK, TR), OAPI (BF, BJ, CF, CG, CI, CM, GA, GN, GQ, GW, ML, MR, NE, SN, TD, TG).

**Published:**  
— without international search report and to be republished upon receipt of that report

(81) Designated States (unless otherwise indicated, for every kind of national protection available): AE, AG, AL, AM,

(54) Title: ELECTRIC POWER GENERATING SOLAR ROOF TILE AND A PROCEDURE FOR ITS PRODUCTION

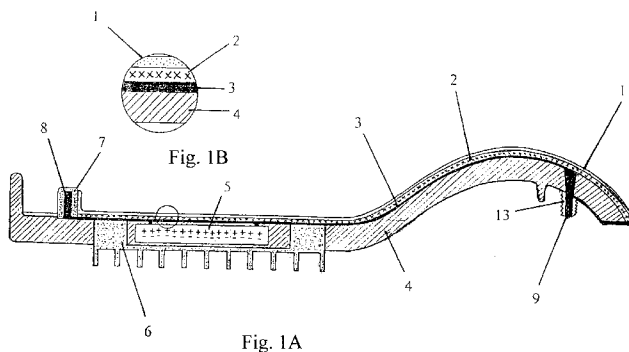

(57) Abstract: The invention relates to an electric power generating solar roof tile and a procedure for its production. The invention is characterized in that the solar cell roof tile (10) possesses a substrate (4) made from plastic or synthetic resin formed into the appropriate shape and size and a flexible solar cell layer (2) containing solar cells applied to the outer surface of the substrate (4), there are conductive rails (3) and connectors in and/or on the surface of the substrate (4), furthermore the solar cell layer (2) is either directly or via a conductive stud (9) connected to the conductive rails (3), and the solar cell layer (2) is sealed in a waterproof manner by a transparent protective layer (1) that tightly conforms to the shape of the outer surface of the substrate (4).

WO 2009/071956 A2

## **Electric Power Generating Solar Roof Tile and a Procedure for its Production**

The subject of the invention is an electric power generating solar roof tile which is covered with solar cells on its outer surface. The solar cells are equipped with conductors and connectors. Further object of the invention is the production process of the power generating solar roof tile. The solar roof tile can be installed into a roof cladding consisting of roof tiles of any shape. It fits exactly in place of the existing tile. It follows the surface and design of the existing tile. The solar roof tiles can be used for solar roofing, facades and building paneling.

The direct conversion of sunlight into electric power by solar panels and cells has been known for a long time. However, during the last century, solar panel experiments had more academic significance than practical applications because of their expensive production and low efficiency. On the other hand, recent technological developments of photovoltaic production made the broad use of solar panels cost-efficient compared to traditional and increasingly expensive coal, oil or gas fuelled power generating systems. That is why the number of patent applications related to this topic has been growing over the past decades.

Hungarian patent specification No. HU 209 222 on equipment utilizing solar power by solar cells is worth mentioning. This patent specification describes a specific arrangement of interconnected solar cells on a support structure. The solar cells made from foil strips or sheets create a solar panel complex and are fitted in a frameless support. The solar panel complex features a trough shaped channel for cooling and for diverting power.

Another Hungarian patent specification under publication number P9901088 introduces a solar panel roof whose overlapped roof components with the built-in solar cells are connected by a bituminous composite material. The solar cells feature extremely thin glass sheets and are in a configuration that prevents other roof components from overlapping them.

Both solar cell inventions described above involve incorporation in an existing roof structure, therefore, they are distinct from the solar cell roof tile subject to the invention.

Document under publication No. JP2001342725 likewise refers to the incorporation of planar solar cells in a roof structure, at the same time exemplifying an embodiment of a solution where solar cells featuring a protective coating of organic resin are strengthened by ribs in order to eliminate the effects of wind pressure.

A US description under publication No. US2006266406 deals with the composition and structural design of devulcanized photoelectric tile covering materials with particular regard to integrating and melting the solar cell into the roof tile substrate. Apart from describing the manner of fabrication and the materials built in, this invention provides no guidance as to the specific design of the roof tile and neither does it attach any relevant drawings.

The document under publication No. MXPA04006204, British publication document filed under No. GB2414114 and Japanese publication document filed under No. JP2005264483 deal with the design of roofing materials and paneling containing solar cells. All three documents deal with the most advantageous design and means of interconnection of solar cells built into carrier and support panels for the benefit of achieving the desired effect and an adequately high voltage.

The roof structure featured in publication document No. US6065256 and Japanese publication document No. JP10018514 is suitable for cooling roofs fitted with solar cells and heating them in the winter in order to melt snow, with the provision that air ducts have been incorporated therein.

The solutions in the inventions featured in the last five publication documents fall far from the alternative in our invention as they address the implementation of certain details or problems only.

The inventions which refer to the production process of solar cells employ the metalloid silicon in most cases. The description under publication No. DE 3626450 is suitable for creating building components containing such solar cells. This alternative is well suited to glazed roofs where the solar cell is created by incorporating and/or applying a plastic film onto which a 0.05 to 1.00 micron amorphous layer of silicon has been applied.

The utility model No. DE 299 15 196 U features flat or specially formed solid, pan-shaped roofing materials containing solar cells, each of which contain a large quantity of solar cells on a thick substrate.

Compared to the solar roof tile subject to our invention, it is clear that solution under the above invention employs relatively large-sized, expensive roofing elements of special design, containing several rows of solar cells. These cannot be combined with existing roof tiles or other sheet metal, etc. roofs through simple replacement as the entire roof must be replaced if the said components are used.

It is a well-know criterion with regard to generally used roof tiles that, when laid up, they fit with the adjacent tiles at the bottom, to and on either side, in other words in every direction, and that they drain the rainwater away. Therefore, any roof sections containing solar cells consisting of planar sheets must be separately sealed in a waterproof fashion from every direction when fitted. This renders their implementation complicated and costly.

Most closely resembling what is embodied in our invention, German publication document No. DE 44 08 508 describes a solution that addresses the above-mentioned criteria for roof tiles. This invention solves the problem by fashioning a roof tile whose bottom, top and side edges are identical in design to the original roof tile. Thus, such tiles can be incorporated in a tiled roof, in place of normal roof tiles, without the need for additional seals. In this alternative, the planar solar cells are only integrated into the central, flat portion of the roof tile so the entire roof surface does not participate in generating electric power, only a portion thereof.

In order to eliminate the above-mentioned deficiencies, our objective is to create a solar cell roof tile and a process for its production in accordance with our invention whereby it is possible to fashion roof tiles that are not only partly but completely identical in shape, form and color, and bear a solar cell layer on their entire outer surface. Therefore, if someone wishes to implement a solar cell roof, they can do so without disrupting the original roof structure or overall appearance thereof, simply by substituting the original roof tiles with the solar cell roof tiles subject to our invention.

The subject of the present invention is an electric power generating solar roof tile which is covered with solar cells on its outer surface. The solar cells are equipped with wires and connectors and it is designed to be fitted in place of any kind of roof tile.

The essence of the solar cell roof tile subject to our invention is that it possesses a substrate made from plastic or synthetic resin formed into the appropriate shape and size with a flexible solar cell layer containing solar cells applied to the outer surface of the substrate, there are conductive rails and connectors in and/or on the surface of the substrate, furthermore the solar cell layer is either directly or via a conductive stud connected to the conductive rails, and the solar cell layer is sealed in a waterproof manner by a transparent protective layer that tightly conforms to the shape of the outer surface of the roof tile fitted with solar cells.

In its preferred embodiment, the unit subject to the invention is implemented as described in Claim 1. The individual examples of embodiment can be implemented according to Claims 2-9.

The essence of the process used to production of the solar cell roof tile subject to our invention is that a negative form or template of the substrate in the form and size intended to be manufactured or used is prepared then the conductive rails and electric connectors are either placed in the negative form or space is left for them to be installed later. In addition, a recess is prepared depending on the type of roof tile for the controller electronics and battery to be installed later then the substrate is produced by pressing, casting or injection molding the chosen plastic material into the negative form.

Then a flexible solar cell layer is applied to both the flat and convex surfaces of the solidified substrate, the solar cell layer is electrically coupled at the appropriate points to the conductive rails and connectors then the substrate fitted with the solar cell layer is covered by a transparent weather, heat and frost resistant layer that protects the tile from mechanical damage and closely fits to the substrate.

The individual process variants are described in Claims 11-15.

The solar cell roof tile described in the invention is introduced in detail in drawings wherein:

- Figure 1a shows an A-A sectional drawing of the solar cell roof tile in a battery equipped embodiment,
- Figure 1b shows a magnified detail of the A-A section described in Figure 1a,
- Figure 2 shows an exploded drawing of the solar cell roof tile subject to the invention.

Figure 1a shows an A-A sectional drawing of the solar cell roof tile according to invention while Figure 2 shows an exploded drawing thereof. Figure 1b shows separately in magnified view the conductive rails 3 mounted on the substrate 4, the solar cell layer 2 and the protective layer 1. It can be clearly seen in these figures that the solar cell roof tile 10 consists of a substrate 4 made from plastic or synthetic resin molded into a roof tile of the desired shape and size with a flexible solar cell layer 2 containing solar cells applied to the outer surface of the substrate 4.

Figure 1a shows a sectional drawing of the solar cell roof tile 10 in an embodiment where the conductive rails 3 are mounted on the surface of the substrate 4. A kind of connector consisting of a socket 7 and a female connector 8 therein is likewise depicted on the surface of the substrate 4. Another kind of connector consisting of a conducting stud 9 is built into the substrate 4. The solar cell layer 2 is electrically connected – partly directly and partly via the conductive stud 9 – with the conductive rails 3 in a configuration corresponding to the proper polarity. The conductive stud 9 is equipped

with an O-ring 13. The solar cell layer 2 completely covers the illuminated outer surface of the substrate 4. In addition, the solar cell layer 2 is sealed in a waterproof manner by a transparent protective layer that conforms to the shape of the outer surface of the substrate 4.

In the embodiment of the solar cell roof tile 10 shown, there is a recess 11 designed to accommodate and facilitate the connection of a battery 5 and controller electronics in the substrate 4, and there is a battery 5 mounted in the recess 11. In the embodiment lacking a battery 5, the recess 11 can be omitted. In the solar cell roof tile 10, optional cooling is provided by a heat sink 6 mounted on the substrate 4, preferably near the recess 11. Figure 1a does not indicate so, but if required a heating filament may be incorporated in the substrate 4 or the protective layer 1 for the purpose of melting snow.

Figure 2 shows that the solar cell roof tile 10 is designed to be laid up in an overlapping fashion with normal roof tiles of matching shape and size. Wherever the solar cell roof tiles 10 overlap, the conductance of electric power between them is provided by conductive studs 9 and female connectors 8 mounted at the appropriate points which interconnect. The figure also shows the error indication light source 12 which is mounted in the upper, non-overlapped part of the substrate 4. Figure 2 includes the marking and configuration of the conductive rails 3 solely for the sake of understanding operation as they are covered by the solar cell layer 2 and the transparent protective layer 1 in reality.

The solar cell roof tile produced using the process subject to the invention has several advantages. The solar roof tile can be installed into a roof cladding consisting of roof tiles of any shape. It does not disrupt the form and unity of the roof surfaces and fits in well. It can even be used on listed buildings because it can be fashioned in any form and color using the process subject to the invention. Furthermore, there is no need to perform any conversions to the roof structure or build in separate units.

An additional advantage of the invention is that the solar cell roof tiles weigh only half as much as conventional roof tiles. A battery can also be fitted to the solar cell roof tile,

which facilitates utilization of the power accumulated during sunny periods at night or on overcast days.

A further advantage is that any defective solar cell roof tiles will indicate if there is an error by illuminating the built-in error indicator light. Thus any malfunctioning solar cell roof tiles can be easily located and replaced.

## CLAIMS

1. An electric power generating solar roof tile whose outer surface is fitted with solar cells where the solar cells are equipped with conductors and connectors **characterized in** that the solar cell roof tile (10) possesses a substrate (4) made from plastic or synthetic resin formed into the appropriate shape and size and a flexible solar cell layer (2) containing solar cells applied to the outer surface of the substrate (4), there are conductive rails (3) and connectors in and/or on the surface of the substrate (4), furthermore the solar cell layer (2) is either directly or via a conductive stud (9) connected to the conductive rails (3), and the solar cell layer (2) is sealed in a waterproof manner by a transparent protective layer (1) that tightly conforms to the shape of the outer surface of the substrate (4).
2. The solar cell roof tile according to Claim 1 **characterized in** that the solar cell layer (2) completely covers the illuminated outer surface of the substrate (4).
3. The solar cell roof tile according to Claim 1 or and 2 **characterized in** that the transparent protective layer (1) is a clear, weather, heat and frost resistant film laminated to the substrate (4) fitted with solar cells.
4. The solar cell roof tile according to any of the Claims 1-3 **characterized in** that it is designed to be laid up in an overlapping fashion with normal roof tiles of matching shape and size.
5. The solar cell roof tile according to any of the Claims 1- 4 **characterized in** that there is a recess (11) designed to accommodate and facilitate connection of a battery (5) and controller electronics in the substrate (4), and there is a battery (5) mounted in the recess (11).
6. The solar cell roof tile according to any of the Claims 1-5 **characterized in** that the bottom surface of the substrate (4), preferably near the recess (11), is fitted with heat sinks (6).

7. The solar cell roof tile according to any of the Claims 1-6 **characterized in** that an error indicator light source (12) is built into the substrate (4) and/or protective layer (1).

8. The solar cell roof tile according to any of the Claims 1-7 **characterized in** that the material of the substrate (4) is a strong, heat, frost and cracking resistant, non-combustible plastic or synthetic resin mixed to provide the appropriate color, or a mixture thereof enriched with a filler material, preferably graded sand.

9. The solar cell roof tile according to any of the Claims 1-8 **characterized in** that a heating filament is built into the substrate (4).

10. A process for manufacturing the solar cell roof tile according to any of the Claims 1-9 **characterized in** that a negative form or template of the substrate (4) in the form and size intended to be manufactured or used is prepared then the conductive rails (3) and electric connectors are either placed in the negative form, or space is left for them to be installed later, while the substrate (4) is produced by pressing, casting or injection molding the chosen plastic material into the negative form then a flexible solar cell layer is applied to both the flat and convex surfaces of the solidified substrate (4), and the solar cell layer (2) is then electrically coupled at the appropriate points to the conductive rails (3) and/or connectors then the substrate (4), already fitted with the solar cell layer, is covered with a transparent, weather, heat and frost resistant protective layer (1) that protects the tile from mechanical damage and closely fits to the substrate (4).

11. The process used to produce the solar cell roof tile according to Claim 10 **characterized in** that, depending on the type of roof tile (10) to be produced, a recess (11) is left for the controller electronics and battery.

12. The process used to produce the solar cell roof tile according to Claim 10 or 11 **characterized in** that the solar cell layer (2) is applied to the surface of the substrate (4) either by integration or gluing, furthermore, when the protective layer (1) covering its surface is being prepared, the substrate (4) fitted with the solar cell layer (2) is covered

throughout its entire surface, including the edges, with a transparent, UV-resistant plastic film preferably 0.5-1 mm thick which is then sealed in a waterproof manner by shrinking it onto the substrate.

13. The process used to produce the solar cell roof tile according to any of the Claims 10-12 **characterized in** that, prior to or during the application of the protective layer (1), an error indication light source (12), preferably a blinking red LED light, is built into the substrate (4) or the edge of the protective layer (1).

14. The process used to produce the solar cell roof tile according to any of the Claims 10-13 **characterized in** that the controller electronics and battery (5) are built into the recess (11) formed in the substrate (4).

15. The process used to produce the solar cell roof tile according to any of the Claims 10-14 **characterized in** that a heat sink (6) made from a good thermal conductor is mounted or glued onto the substrate (4), preferably near the recess (11).

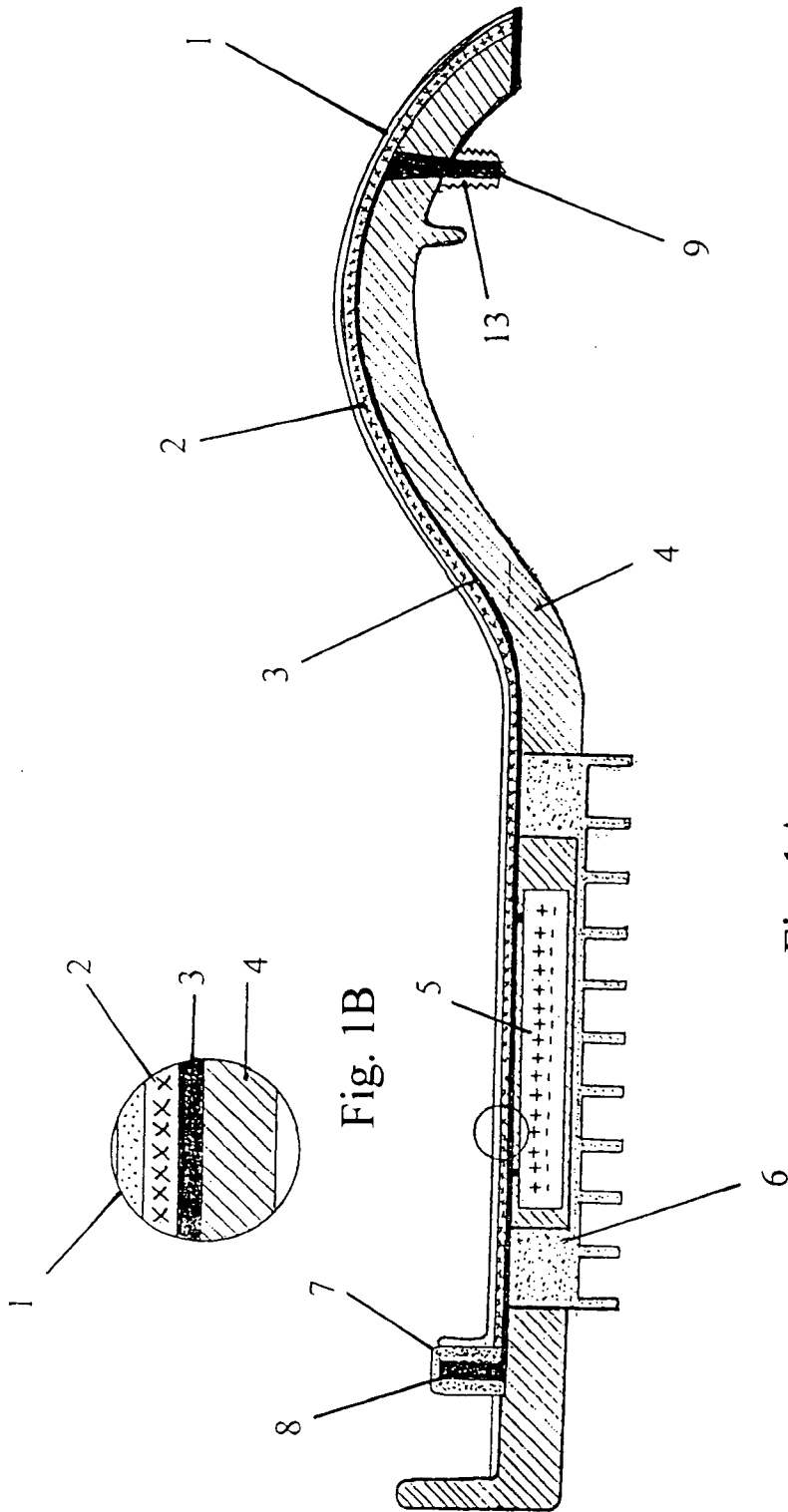

Fig. 1A

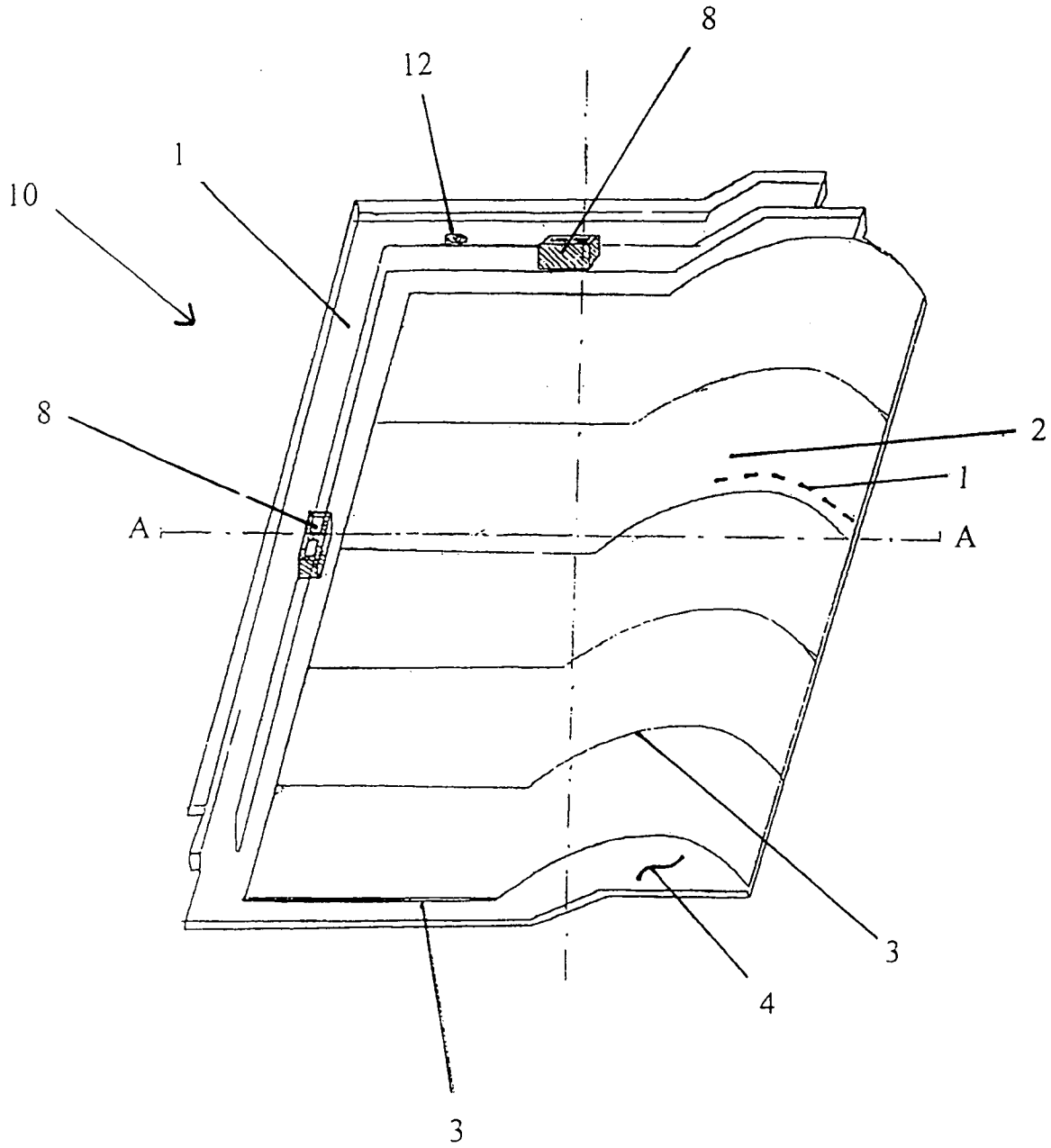

Fig. 2