



- (51) International Patent Classification:
B29C 33/10 (2006.01) F16K 24/04 (2006.01)
B29D 30/06 (2006.01)
- (21) International Application Number: PCT/FI2014/050207
- (22) International Filing Date: 21 March 2014 (21.03.2014)
- (25) Filing Language: Finnish
- (26) Publication Language: English
- (30) Priority Data: 20135278 22 March 2013 (22.03.2013) FI
- (71) Applicant: **WD RACING OY** [FI/FI]; Kuljuntie 9, FI-37200 Siuro (FI).
- (72) Inventor: **PENKKIMÄKI, Pekka**; Kuljuntie 9, FI-37200 Siuro (FI).
- (74) Agent: **HEINÄNEN OY**; Äyritie 8 D, FI-01510 Vantaa (FI).

- (81) Designated States (unless otherwise indicated, for every kind of national protection available): AE, AG, AL, AM, AO, AT, AU, AZ, BA, BB, BG, BH, BN, BR, BW, BY, BZ, CA, CH, CL, CN, CO, CR, CU, CZ, DE, DK, DM, DO, DZ, EC, EE, EG, ES, FI, GB, GD, GE, GH, GM, GT, HN, HR, HU, ID, IL, IN, IR, IS, JP, KE, KG, KN, KP, KR, KZ, LA, LC, LK, LR, LS, LT, LU, LY, MA, MD, ME, MG, MK, MN, MW, MX, MY, MZ, NA, NG, NI, NO, NZ, OM, PA, PE, PG, PH, PL, PT, QA, RO, RS, RU, RW, SA, SC, SD, SE, SG, SK, SL, SM, ST, SV, SY, TH, TJ, TM, TN, TR, TT, TZ, UA, UG, US, UZ, VC, VN, ZA, ZM, ZW.
- (84) Designated States (unless otherwise indicated, for every kind of regional protection available): ARIPO (BW, GH, GM, KE, LR, LS, MW, MZ, NA, RW, SD, SL, SZ, TZ, UG, ZM, ZW), Eurasian (AM, AZ, BY, KG, KZ, RU, TJ, TM), European (AL, AT, BE, BG, CH, CY, CZ, DE, DK, EE, ES, FI, FR, GB, GR, HR, HU, IE, IS, IT, LT, LU, LV, MC, MK, MT, NL, NO, PL, PT, RO, RS, SE, SI, SK, SM, TR), OAPI (BF, BJ, CF, CG, CI, CM, GA, GN, GQ, GW, KM, ML, MR, NE, SN, TD, TG).

[Continued on next page]

(54) Title: AIR VENTING VALVE

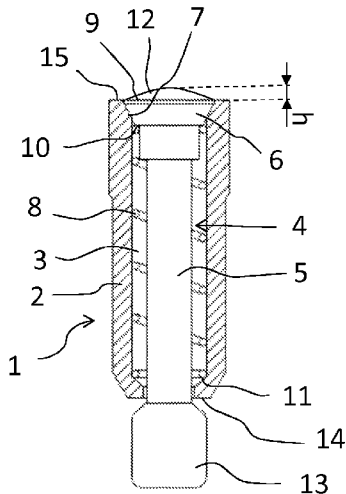
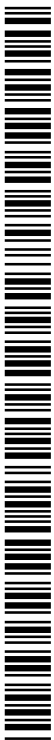

Fig. 1

(57) Abstract: An air venting valve (1) for removing air from a vulcanising mould of a vehicle tyre. The air venting valve (1) comprises a valve sleeve (2), an air venting channel (3) arranged inside the valve sleeve (2), and a movable inner part (4) arranged in the valve sleeve (2), which comprises a stem (5), the end of which is provided with a valve disc (6) for opening and closing the air venting channel (3). The valve disc (6) is against a stop surface (7) of the valve sleeve (2) in a closed position of the air venting valve (1) and in an open position at a clearance from said stop surface (7). Furthermore, the air venting valve (1) comprises a spring member (8) for forcing the inner part (4) towards opening position. The front surface (9) of the valve disc (6) comprises a bulge (12).



Published:

— *with international search report (Art. 21(3))*

AIR VENTING VALVE

This invention relates to an air venting valve for removing air from a vulcanising mould of a vehicle tyre.

5

In vulcanising moulds of vehicle tyres, air venting holes or channels are used because, in the vulcanising of a tyre, a tyre blank smaller than the inner dimensions of the mould is placed inside the mould, after which the mould is closed. After closing, the tyre blank is caused to expand, whereby it presses
10 against the surface of the mould in its plastic mode acquiring the size and shape of a tyre. In connection with closing the vulcanising mould, air between the tyre blank and the mould surface has to be removed in order for the surface of the tyre blank to come into a tight contact with the mould surface. There should be several of these air removal holes or channels in order for air to be
15 removed completely at each point of the mould and no air pockets to remain between the tyre and the mould.

An air venting valve typically used in air venting channels in vulcanising moulds of vehicle tyres comprises a stem inside the air venting channel, which stem is
20 thinner than the diameter of the channel, and a valve disc, which is fastened in the stem and is placed in the area of the mould surface. On the inner surface of the mould, there is a stop recess for the valve disc. A coil spring is arranged around the stem which coil spring supports itself in the mould and in the valve disc either directly or via the stem and via a flange fastened to the stem. The
25 spring aims to press the valve disc away from the mould wall towards the tyre blank, whereby air is able to exit from the mould via a clearance between the valve disc and the stop recess and further via a gap between the stem and the air venting channel. As the material being vulcanised, when expanding, advances towards the mould surface, it pushes ahead of it the valve disc, which
30 then finally presses tightly in the stop recess closing the air channel, whereby the material being vulcanised cannot access the air venting channel. The spring then opens the valve while the tyre blank is being removed from the mould.

A disadvantage of the solution described above is that the material being
35 vulcanised is soft, whereby material might pass the valve disc towards the air venting channel before the valve disc is closed. The material being vulcanised thus blocks the valve and prevents it from closing.

The aim of the present invention is to provide an air venting valve, which eliminates the problem described above.

The aim according to the invention is achieved as described in claim 1. An air venting valve according to the invention comprises a valve sleeve, an air venting channel arranged inside the valve sleeve, and a movable inner part arranged in the valve sleeve, which inner part comprises a stem, an end of which is provided with a valve disc for opening and closing the air venting channel. The valve disc is against a stop surface of the valve sleeve in a closed position of the air venting valve and in an open position at a clearance from said stop surface. Furthermore, the air venting valve comprises a spring member for forcing the inner part towards the open position. A front surface of the valve disc is provided with a bulge.

With the solution according to the invention, significant advantages are achieved. The bulge in the front surface of the valve disc causes the air venting valve to close sooner than normally, whereby no material being vulcanised passes the valve disc into the air venting channel before the air venting valve is closed. In that way the air venting valve is prevented from being blocked. With the aid of a bulge an impression, e.g. a logo, of a desired shape, can be made to the material being vulcanised by shaping the bulge appropriately.

In the following, the invention will be described in more detail by means of examples with reference to the attached drawings, wherein

25

Fig. 1 presents one embodiment of an air venting valve according to the invention, and

Figs. 2–7 present different inner parts of the valve that can be used in the air venting valve of Fig.1.

30

The inner surface of a vulcanising mould of a vehicle tyre provides a vulcanised tyre its outer surface shape and tread patterns with their details in the tread area. Thus, on the mould surface of the vulcanising mould, which shapes the tread there are, inter alia, bulges forming tread grooves and recesses forming pattern parts. In the vulcanising mould there are a number of air venting valves 1 through which air from between the tyre blank and mould surface can be removed. There are different numbers of air venting valves 1 in vulcanising

35

moulds of vehicle tyres depending on the size and type of the tyre. For example, there are generally 1200–2000 and 2000–4500 air venting valves 1, respectively, in the summer and winter tyres of passenger cars.

5 Fig. 1 presents an air venting valve 1 for removing air from a vulcanising mould of a vehicle tyre. The air venting valve 1 comprises a valve sleeve 2. The valve sleeve 2 is of cylindrical shape, its outer surface is smooth or provided with outer threads. An air venting channel 3 is arranged inside the valve sleeve 2 for removing air from between the tyre blank and mould surface. The air venting
10 channel 3 extends through the wall of the vulcanising mould from inside of the mould to outside of the mould.

The air venting valve 1 comprises also a movable inner part 4 arranged in the valve sleeve 2, comprising a stem 5 the end of which is provided with a valve
15 disc 6 for opening and closing the air venting channel 3. A stop surface 7 is arranged in the valve sleeve 2 for the valve disc 6. The valve disc 6 is in a closed position of the air venting valve 1 against the stop surface 7 and in an open position at a clearance from said stop surface 7. In the open position the valve disc 6 protrudes from an end 15 of the valve sleeve 2. The valve disc 6
20 comprises a front surface 9, which is directed towards the inner part of the vulcanising mould and which comes in contact with outer face of the tyre blank while the air venting valve 1 is closing. The tyre material, when expanding, thus forces the air venting valve 1 towards the closing position. The other end of the stem 5 in the inner part is provided with a projecting part 13, which is adjusted
25 to support itself on the other end 14 of the valve sleeve 2 while the air venting valve 1 is in open position. The projecting part 13 thus limits the movement of the inner part 4 in the open position. The maximum stroke of the air venting valve 1, i.e. the maximum travel of the inner part 4 is in the longitudinal direction
0.2-0.5 mm.

30 The air venting valve 1 comprises a spring member 8 for forcing the inner part 4 towards the open position. The spring member 8 is arranged inside of the valve sleeve 2 between a back surface 10 of the valve disc 6 and a support surface 11 arranged in the valve sleeve 2. The spring member 8 is arranged around the
35 stem 5 of the inner part. The spring member 8 can be e.g. a coil spring.

The front surface 9 of the valve disc 6 is provided with a bulge 12, which causes the air venting valve 1 to close sooner than normally. Then the material being

vulcanised does not pass the valve disc into the air venting channel 3 before the air venting valve is closed. In that way the air venting valve is being prevented from blocking. The height (h) of the bulge 12 is 0.01-1.5mm, generally 0.5-1mm. The height (h) of the bulge can be, e.g. 0.1-0.6mm. The height h is the distance
5 between the end 15 of the valve sleeve and the front point of the bulge in the longitudinal direction of stem 5 while the air venting valve 1 is in a closed position. Different embodiments of the bulge 12 are shown in figures 2-7.

10 In Fig. 2 the bulge 12 is convex and it extends over the whole area of the front surface 9 of the valve disc.

In Fig. 3 the bulge 12 is convex and it extends only over the part of the front surface 9 area.

15 In Fig. 4 the bulge 12 is of cylindrical shape.

In Fig. 5 the bulge 12 is of the shape of a truncated cone. The broader end of the bulge 12 is in front.

20 In Fig. 6 the bulge 12 is of the shape of a truncated cone. The narrower end of the bulge 12 is in front. The bulge 12 extends over the whole area of the front surface 9 of the valve disc.

25 In Fig. 7 the bulge 12 is of cone apex shape. The bulge 12 extends over the whole area of the front face 9 of the valve disc.

In the closed position of figure 1 the whole front surface 9 (bulge 12) of the valve disc 6 protrudes from the valve sleeve 2 (embodiments of figures 2, 6 and 7), or a part of the front surface 9 (bulge 12) protrudes from the valve sleeve 2
30 and the other part of the front surface 9 is on the same level as the end 15 of the valve sleeve (embodiments of figures 3, 4 and 5). In the embodiments of figures 2, 3, 6 and 7 the bulge 12 narrows towards its top. The air venting valve 1 according to the invention functions for removing air from a vulcanising mould of a vehicle tyre during the vulcanising of a tyre as follows. A tyre blank is set in
35 the vulcanising mould, which tyre blank is caused to expand by pressing air and/or steam inside of it, whereby the outer surface of the tyre blank presses against the mould surface gaining its final surface shape, i.e. the surface pattern of the tyre tread, from it. At the same time, the vulcanising mould is heated for

vulcanising the rubber material of the tyre blank and for achieving the finished tyre. In order for the outer surface of the tyre blank to set as precisely as possible against the inner surface of the mould, air is removed from between the tyre blank and the mould surface via air venting valves 1 according to the invention.

The spring member 8 keeps the air venting valve 1 in an open position, whereby air can be removed via the air venting channel 3 from between the tyre blank and the mould surface. As the tyre material, when expanding, advances towards the mould surface, it pushes ahead of it the valve disc 6, which then finally presses against the stop surface 7 thus closing the air channel 3, whereby the tyre material cannot access the air venting channel 3. When the tyre blank is removed from the mould, a spring member 8 moves the inner part 4 to open position.

The bulge 12 in the front surface 9 of a valve disc causes the air venting valve 1 to close sooner than in the ordinary air venting valve (smooth front surface), whereby no material being vulcanised passes the valve disc 6 into the air venting channel 3 before the air venting valve 1 is closed. In that way the air venting valve 1 is prevented from being blocked. With the aid of the bulge 12 an imprint, e.g. a logo, of a desired shape, can be made to the material being vulcanised by shaping the bulge 12 appropriately.

It is obvious to the person skilled in the art that the different embodiments of the invention are not solely limited to the example described above, but they may vary within the scope of the claims presented below. The invention can also be applied to others than the vulcanising moulds of a vehicle tyre.

30

CLAIMS

1. An air venting valve (1) for removing air from a vulcanising mould of a vehicle tyre, which air venting valve (1) comprises
- 5 - a valve sleeve (2),
- an air venting channel (3) arranged inside the valve sleeve (2), and
- a movable inner part (4) arranged in the valve sleeve (2), which comprises a stem (5), the end of which is provided with a valve disc (6) for opening and closing the air venting channel (3),
- 10 which valve disc (6) is against a stop surface (7) of the valve sleeve (2) in a closed position of the air venting valve (1) and in an open position at a clearance from said stop surface (7), and
- a spring member (8) for forcing the inner part (4) towards the open
- 15 position, **characterised** in that the front surface (9) of the valve disc (6) is provided with a bulge (12).
2. An air venting valve (1) according to claim 1, **characterised** in that the height (h) of the bulge (12) is 0.01–1.5mm.
- 20 3. An air venting valve (1) according to claim 1 or 2, **characterised** in that the bulge (12) is convex.
4. An air venting valve (1) according to claim 1 or 2, **characterised** in that the bulge (12) is of the shape of a truncated cone.
- 25 5. An air venting valve (1) according to claim 1 or 2, **characterised** in that the bulge (12) is of the cylindrical shape.
- 30 6. An air venting valve (1) according to any one of preceding claims, **characterised** in that the bulge (12) extends over the whole front surface (9) area or only over a part of the front surface (9) area.
7. An air venting valve (1) according to any one of preceding
- 35 claims, **characterised** in that the other end of the stem (5) is provided with a projecting part (13), which is arranged to support itself to the other end (14) of the valve sleeve while the air venting valve (1) is in the open position.

8. An air venting valve according to any one of preceding claims, **characterised** in that the whole front surface (9) of the valve disc (6) protrudes from the valve sleeve (2) or that a part of the front surface (9) protrudes from the valve sleeve (2) and the other part of the front surface (9) is on the same level as the end (15) of the valve sleeve when the air venting valve (1) is in the closed position.

9. An air venting valve according to any one of preceding claims, **characterised** in that the bulge (12) narrows towards its top.

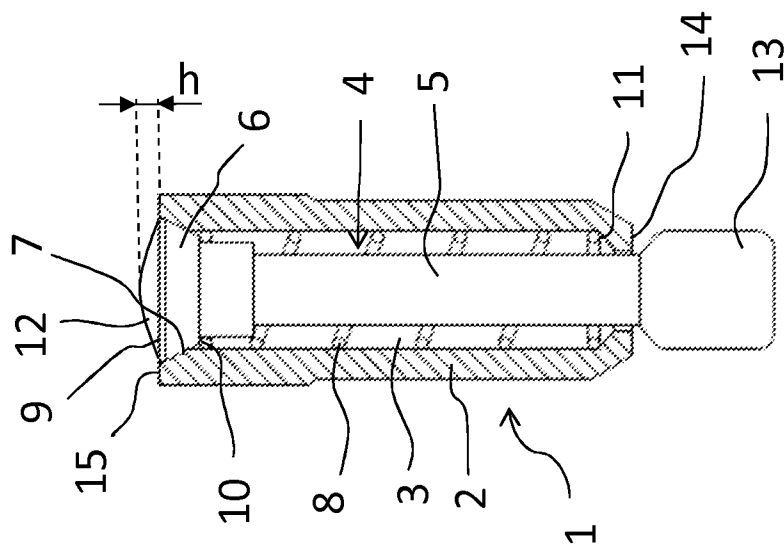

Fig. 1

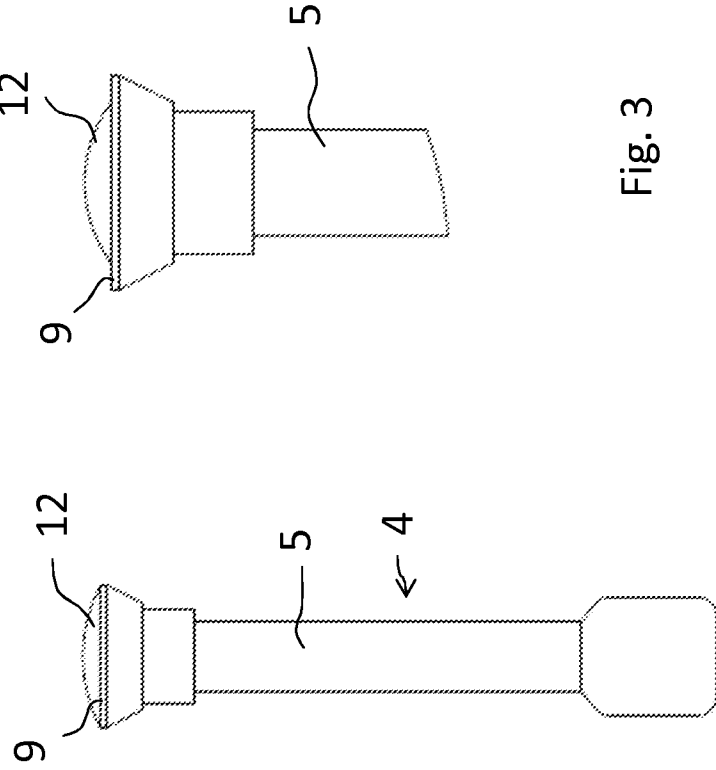

Fig. 2

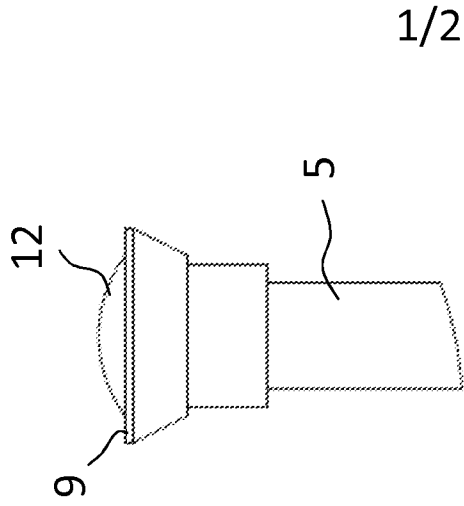

Fig. 3

1/2

2/2

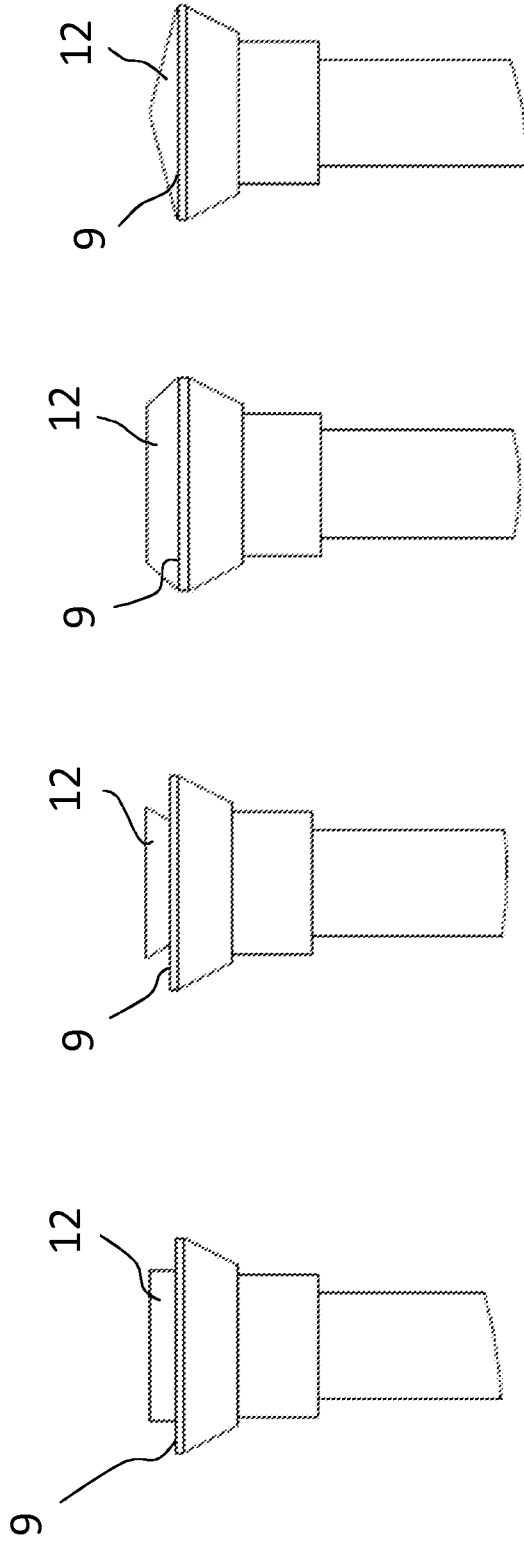

Fig. 7

Fig. 6

Fig. 5

Fig. 4

INTERNATIONAL SEARCH REPORT

International application No.

PCT/FI2014/050207

A. CLASSIFICATION OF SUBJECT MATTER

See extra sheet

According to International Patent Classification (IPC) or to both national classification and IPC

B. FIELDS SEARCHED

Minimum documentation searched (classification system followed by classification symbols)

IPC: B29C, B29D, F16K

Documentation searched other than minimum documentation to the extent that such documents are included in the fields searched

FI, SE, NO, DK

Electronic data base consulted during the international search (name of data base and, where practicable, search terms used)

EPO-Internal, WPI

C. DOCUMENTS CONSIDERED TO BE RELEVANT

Category*	Citation of document, with indication, where appropriate, of the relevant passages	Relevant to claim No.
X	US 2012027880 A1 (CAZZANTI STEFANO [IT] et al.) 02 February 2012 (02.02.2012) whole document, especially page 4, paragraph [0070] - page 5, paragraph [0080]; figures 2 and 4	1, 2, 4, 6, 7, 9
Y		3
X	JP 2011116012 A (YOKOHAMA RUBBER CO LTD) 16 June 2011 (16.06.2011) figures 1-5 & abstract [online] EPOQUENET PAJ	1, 4-8
Y		3
Y	KR 100957800 B1 (YUN HEA SEOG [KR]) 13 May 2010 (13.05.2010) figures 7-8b & abstract [online] EPOQUENET EPODOC & WPI	3
Y	EP 2524787 A1 (CONTINENTAL REIFEN DEUTSCHLAND [DE]) 21 November 2012 (21.11.2012) abstract; column 4, paragraph [0020]; figures 2 and 3	3

 Further documents are listed in the continuation of Box C.
 See patent family annex.

* Special categories of cited documents:	"T" later document published after the international filing date or priority date and not in conflict with the application but cited to understand the principle or theory underlying the invention
"A" document defining the general state of the art which is not considered to be of particular relevance	"X" document of particular relevance; the claimed invention cannot be considered novel or cannot be considered to involve an inventive step when the document is taken alone
"E" earlier application or patent but published on or after the international filing date	"Y" document of particular relevance; the claimed invention cannot be considered to involve an inventive step when the document is combined with one or more other such documents, such combination being obvious to a person skilled in the art
"L" document which may throw doubts on priority claim(s) or which is cited to establish the publication date of another citation or other special reason (as specified)	"&" document member of the same patent family
"O" document referring to an oral disclosure, use, exhibition or other means	
"P" document published prior to the international filing date but later than the priority date claimed	

Date of the actual completion of the international search

23 June 2014 (23.06.2014)

Date of mailing of the international search report

24 June 2014 (24.06.2014)

Name and mailing address of the ISA/FI
Finnish Patent and Registration Office
P.O. Box 1160, FI-00101 HELSINKI, Finland
Facsimile No. +358 9 6939 5328

Authorized officer
Lauri Louhiluoto
Telephone No. +358 9 6939 500

INTERNATIONAL SEARCH REPORT

International application No.

PCT/FI2014/050207

C (Continuation). DOCUMENTS CONSIDERED TO BE RELEVANT

Category*	Citation of document, with indication, where appropriate, of the relevant passages	Relevant to claim No.
A	JP H04123859 A (RYOBI LTD) 23 April 1992 (23.04.1992) figure 1 & abstract [online] EPOQUENET PAJ	9
A	FI 106938 B (NOKIAN RENKAAT OYJ [FI]) 15 May 2001 (15.05.2001) whole document, especially figure 4	1-9

INTERNATIONAL SEARCH REPORT
Information on patent family members

International application No.
PCT/FI2014/050207

Patent document cited in search report	Publication date	Patent family members(s)	Publication date
US 2012027880 A1	02/02/2012	US 8506274 B2	13/08/2013
		BR PI0419250 A	11/03/2008
		CN 101076438 A	21/11/2007
		CN 100584563 C	27/01/2010
		EP 1833649 A1	19/09/2007
		EP 1833649 B1	13/02/2013
		WO 2006070413 A1	06/07/2006
		US 2008302463 A1	11/12/2008
		US 8048247 B2	01/11/2011
		US 8506274 B2	13/08/2013
		BR PI0419250 A	11/03/2008
		CN 101076438 A	21/11/2007
		CN 100584563 C	27/01/2010
		EP 1833649 A1	19/09/2007
		EP 1833649 B1	13/02/2013
		WO 2006070413 A1	06/07/2006
		US 2008302463 A1	11/12/2008
US 8048247 B2	01/11/2011		
.....			
JP 2011116012 A	16/06/2011	None None	
.....			
KR 100957800 B1	13/05/2010	None None	
.....			
EP 2524787 A1	21/11/2012	DE 102011050409 A1 DE 102011050409 A1	22/11/2012 22/11/2012
.....			
JP H04123859 A	23/04/1992	JP H084909 B2 JP H084909 B2	24/01/1996 24/01/1996
.....			
FI 106938 B	15/05/2001	None	
.....			

CLASSIFICATION OF SUBJECT MATTER

Int. Cl.
B29C 33/10 (2006.01)
B29D 30/06 (2006.01)
F16K 24/04 (2006.01)