

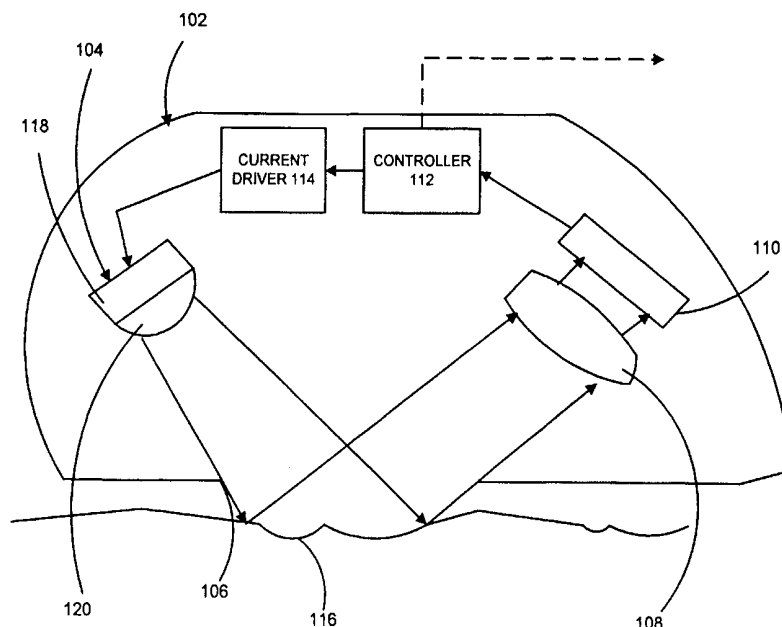

INTERNATIONAL APPLICATION PUBLISHED UNDER THE PATENT COOPERATION TREATY (PCT)

<p>(51) International Patent Classification ⁶ : G06K 11/08, 11/18</p>	<p>A1</p>	<p>(11) International Publication Number: WO 99/39304 (43) International Publication Date: 5 August 1999 (05.08.99)</p>
<p>(21) International Application Number: PCT/US99/01706 (22) International Filing Date: 27 January 1999 (27.01.99) (30) Priority Data: 60/073,303 28 January 1998 (28.01.98) US 09/036,809 9 March 1998 (09.03.98) US (71) Applicant: MICROSOFT CORPORATION [US/US]; One Microsoft Way, Redmond, WA 98052-6399 (US). (72) Inventors: ADAN, Manolito, E.; 16843 N.E. 159th Place, Woodinville, WA 98072 (US). AOYAGI, Tetsuji; 2-12-38 Aobadai, Aoba-ku, Yokohama-shi, Kanagawa-ken (JP). HOLMDAHL, Todd, E.; 2314 - 137th Place S.E., Bothell, WA 98021 (US). LIPSCOMB, Terry, M.; 103 Cascade Key, Bellevue, WA 98006 (US). MIURA, Takeshi; 4-15-1 Ooaza-Kashida, Hirosaki-shi, Aomori-ken (JP). (74) Agents: KELLY, Joseph, R. et al.; Westman, Champlin & Kelly, P.A., Suite 1600 - International Centre, 900 Second Avenue South, Minneapolis, MN 55402-3319 (US).</p>	<p>(81) Designated States: AL, AM, AT, AU, AZ, BA, BB, BG, BR, BY, CA, CH, CN, CU, CZ, DE, DK, EE, ES, FI, GB, GE, GH, GM, HU, ID, IL, IN, IS, JP, KE, KG, KP, KR, KZ, LC, LK, LR, LS, LT, LU, LV, MD, MG, MK, MN, MW, MX, NO, NZ, PL, PT, RO, RU, SD, SE, SG, SI, SK, SL, TJ, TM, TR, TT, UA, UG, UZ, VN, YU, ZW, ARIPO patent (GH, GM, KE, LS, MW, SD, SZ, UG, ZW), Eurasian patent (AM, AZ, BY, KG, KZ, MD, RU, TJ, TM), European patent (AT, BE, CH, CY, DE, DK, ES, FI, FR, GB, GR, IE, IT, LU, MC, NL, PT, SE), OAPI patent (BF, BJ, CF, CG, CI, CM, GA, GN, GW, ML, MR, NE, SN, TD, TG).</p> <p>Published <i>With international search report.</i></p>	

(54) Title: OPERATOR INPUT DEVICE



(57) Abstract

An operator input device (40) is configured to provide position information based on relative movement of a surface (116) and the operator input device (40). The operator input device (40) includes an image detector (110) which is configured to detect an image on the surface (116) and provide an image signal corresponding to the image detected. A controller (112) is coupled to the image detector (110) and is configured to receive the image signal and provide the position information based on a position of the image relative to the image detector (110).

FOR THE PURPOSES OF INFORMATION ONLY

Codes used to identify States party to the PCT on the front pages of pamphlets publishing international applications under the PCT.

AL	Albania	ES	Spain	LS	Lesotho	SI	Slovenia
AM	Armenia	FI	Finland	LT	Lithuania	SK	Slovakia
AT	Austria	FR	France	LU	Luxembourg	SN	Senegal
AU	Australia	GA	Gabon	LV	Latvia	SZ	Swaziland
AZ	Azerbaijan	GB	United Kingdom	MC	Monaco	TD	Chad
BA	Bosnia and Herzegovina	GE	Georgia	MD	Republic of Moldova	TG	Togo
BB	Barbados	GH	Ghana	MG	Madagascar	TJ	Tajikistan
BE	Belgium	GN	Guinea	MK	The former Yugoslav Republic of Macedonia	TM	Turkmenistan
BF	Burkina Faso	GR	Greece	ML	Mali	TR	Turkey
BG	Bulgaria	HU	Hungary	MN	Mongolia	TT	Trinidad and Tobago
BJ	Benin	IE	Ireland	MR	Mauritania	UA	Ukraine
BR	Brazil	IL	Israel	MW	Malawi	UG	Uganda
BY	Belarus	IS	Iceland	MX	Mexico	US	United States of America
CA	Canada	IT	Italy	NE	Niger	UZ	Uzbekistan
CF	Central African Republic	JP	Japan	NL	Netherlands	VN	Viet Nam
CG	Congo	KE	Kenya	NO	Norway	YU	Yugoslavia
CH	Switzerland	KG	Kyrgyzstan	NZ	New Zealand	ZW	Zimbabwe
CI	Côte d'Ivoire	KP	Democratic People's Republic of Korea	PL	Poland		
CM	Cameroon	KR	Republic of Korea	PT	Portugal		
CN	China	KZ	Kazakistan	RO	Romania		
CU	Cuba	LC	Saint Lucia	RU	Russian Federation		
CZ	Czech Republic	LI	Liechtenstein	SD	Sudan		
DE	Germany	LK	Sri Lanka	SE	Sweden		
DK	Denmark	LR	Liberia	SG	Singapore		
EE	Estonia						

OPERATOR INPUT DEVICE

BACKGROUND OF THE INVENTION

The present invention relates to an input device for a computer system. More specifically, the present invention relates to an input device for providing position information to the computer system based on movement of the input device.

A traditional computer input device, such as a mouse, includes a housing, with a ball mounted in the housing. The ball is either configured in a traditional manner in which, in the normal work position, the ball engages a work surface and rotates based on the user's movement of the mouse across the work surface. The ball may also be provided as a track ball, which is rotated by digital manipulation from the user. In either case, position encoders are used to detect rotation of the ball in the mouse, and to provide position information indicative of that rotation to the computer. In many instances, the position information is used to control movement of a visual image (such as a mouse cursor) on the display screen of the computer.

Also, in one prior device, a mouse is configured with the track ball arrangement described above. The track ball is preprinted with a predetermined image. A charge coupled device is used to detect the image on the track ball and detect movement of the image. Movement of the predefined image is used to provide position information to the computer.

However, the prior computer mouse which uses the charge coupled device configuration has a number of significant disadvantages. First, the reaction time of charge coupled devices is quite slow. In addition,

processing an image signal from a charge coupled device is computationally intensive and takes a relatively large, and expensive processor. Also, charge coupled devices are highly sensitive to saturation. In other words, if the ambient light conditions are variable, charge coupled devices do not perform well. In addition, if an extraneous light source, such as a flashlight, is directed toward the image producing surface, the charge coupled devices can easily become saturated and their performance then quickly degrades.

Further, another prior computer mouse commercially available from Mouse Systems of CA included a mouse with an LED which was used in conjunction with a mouse pad having a predetermined pattern thereon. The pattern was formed by a grid of blue and red lines. The emissions from the LED was reflected off of the mouse pad to a detector which provided an analog output signal. The signal was in the form of a waveshape with peaks corresponding to the different colored grid lines. From this waveform, the lines were counted and interpolated to obtain position information. Such a mouse system requires a special mouse pad with a special pattern implemented thereon.

SUMMARY OF THE INVENTION

An operator input device is configured to provide position information based on relative movement of the operator input device and surface. The operator input device includes a pattern detector which is configured to detect a pattern on the surface and provide a pattern image signal corresponding to the pattern detected. The surface has no predefined pattern

thereon. A controller is coupled to the pattern detector and is configured to receive the image signal and provide the position information based on a position of the pattern relative to the pattern
5 detector.

In one preferred embodiment, the controller is coupled to the pattern detector and is configured to receive a primary image signal at an initial time and receive a secondary image a variable time later. The
10 controller computes and provides the position information based on a determination of the motion changes observed from the primary image to the secondary image.

BRIEF DESCRIPTION OF THE DRAWINGS

15 FIG. 1 is a block diagram of an exemplary environment for implementing an input device in accordance with the present invention.

FIG. 2 illustrates a computer input device, shown in partial sectional and partial block diagram form,
20 in accordance with one aspect of the present invention.

FIGS. 3A-3F illustrate the movement of images or patterns detected by the computer input device illustrated in FIG. 2.

25 FIGS. 4A and 4B are flow diagrams illustrating the operation of a computer input device in accordance with certain aspects of the present invention.

FIG. 5 illustrates a multiple source electromagnetic radiation emitter in accordance with
30 one aspect of the present invention.

FIGS. 6A-6D illustrate imaging areas for detecting rotation of the operator input device.

FIGS. 7A and 7B illustrate an operator input

device in accordance with another aspect of the present invention.

FIGS. 8A-8D illustrate detection of images or patterns using the operator input device illustrated in FIGS. 7A and 7B.

FIG. 9A is a block diagram of a portion of a user input device in accordance with another aspect of the present invention.

FIGS. 9B-9E illustrate detection of patterns using the user input device shown in FIG. 9A.

FIG. 10A is a block diagram of a portion of a user input device in accordance with another aspect of the present invention.

FIG. 10B illustrates detection of patterns using the device shown in FIG. 10A.

FIG. 11A is a block diagram of a portion of a user input device in accordance with another aspect of the present invention.

FIG. 11B illustrates detection of patterns using the device shown in FIG. 11A.

FIG. 12A is a block diagram of a portion of a user input device in accordance with another aspect of the present invention.

FIG. 12B illustrates a waveform generated by a portion of the user input device shown in FIG. 12A.

DETAILED DESCRIPTION OF THE PREFERRED EMBODIMENTS

The present invention provides a user input device for generating position information and providing that information to a computer system. The position information is generated based on detected movement of the user input device, or a portion thereof. The movement is detected by identifying a pattern or image on a surface movable relative to the

user input device and monitoring relative movement of the pattern.

Overview

FIG. 1 and the related discussion are intended to provide a brief, general description of a suitable computing environment in which the invention may be implemented. Although not required, the invention will be described, at least in part, in the general context of computer-executable instructions, such as program modules, being executed by a personal computer or other computing device. Generally, program modules include routine programs, objects, components, data structures, etc. that perform particular tasks or implement particular abstract data types. Moreover, those skilled in the art will appreciate that the invention may be practiced with other computer system configurations, including hand-held devices, multiprocessor systems, microprocessor-based or programmable consumer electronics, network PCs, minicomputers, mainframe computers, and the like. The invention is also applicable in distributed computing environments where tasks are performed by remote processing devices that are linked through a communications network. In a distributed computing environment, program modules may be located in both local and remote memory storage devices.

With reference to FIG. 1, an exemplary environment for the invention includes a general purpose computing device in the form of a conventional personal computer 20, including processing unit 21, a system memory 22, and a system bus 23 that couples various system components including the system memory to the processing unit 21. The system bus 23 may be

any of several types of bus structures including a memory bus or memory controller, a peripheral bus, and a local bus using any of a variety of bus architectures. The system memory includes read only memory (ROM) 24 a random access memory (RAM) 25. A basic input/output 26 (BIOS), containing the basic routine that helps to transfer information between elements within the personal computer 20, such as during start-up, is stored in ROM 24. The personal computer 20 further includes a hard disk drive 27 for reading from and writing to a hard disk (not shown), a magnetic disk drive 28 for reading from or writing to removable magnetic disk 29, and an optical disk drive 30 for reading from or writing to a removable optical disk 31 such as a CD ROM or other optical media. The hard disk drive 27, magnetic disk drive 28, and optical disk drive 30 are connected to the system bus 23 by a hard disk drive interface 32, magnetic disk drive interface 33, and an optical drive interface 34, respectively. The drives and the associated computer-readable media provide nonvolatile storage of computer readable instructions, data structures, program modules and other data for the personal computer 20.

Although the exemplary environment described herein employs a hard disk, a removable magnetic disk 29 and a removable optical disk 31, it should be appreciated by those skilled in the art that other types of computer readable media which can store data that is accessible by a computer, such as magnetic cassettes, flash memory cards, digital video disks, Bernoulli cartridges, random access memories (RAMs), read only memory (ROM), and the like, may also be used in the exemplary operating environment.

A number of program modules may be stored on the hard disk, magnetic disk 29, optical disk 31, ROM 24 or RAM 25, including an operating system 35, one or more application programs 36, other program modules 5 37, and program data 38. A user may enter commands and information into the personal computer 20 through input devices such as a keyboard 42 and pointing device 40. Other input devices (not shown) may include a microphone, joystick, game pad, satellite 10 dish, scanner, or the like. These and other input devices are often connected to the processing unit 21 through a serial port interface 46 that is coupled to the system bus 23, but may be connected by other interfaces, such as a sound card, a parallel port, a 15 game port or a universal serial bus (USB). A monitor 47 or other type of display device is also connected to the system bus 23 via an interface, such as a video adapter 48. In addition to the monitor 47, personal computers may typically include other peripheral 20 output devices such as speaker 45 and printers (not shown).

The personal computer 20 may operate in a networked environment using logic connections to one or more remote computers, such as a remote computer 25 49. The remote computer 49 may be another personal computer, a server, a router, a network PC, a peer device or other network node, and typically includes many or all of the elements described above relative to the personal computer 20, although only a memory 30 storage device 50 has been illustrated in FIG. 1. The logic connections depicted in FIG. 1 include a local area network (LAN) 51 and a wide area network (WAN) 52. Such networking environments are commonplace in

offices, enterprise-wide computer network intranets and the Internet.

When used in a LAN networking environment, the personal computer 20 is connected to the local area network 51 through a network interface or adapter 53. When used in a WAN networking environment, the personal computer 20 typically includes a modem 54 or other means for establishing communications over the wide area network 52, such as the Internet. The modem 54, which may be internal or external, is connected to the system bus 23 via the serial port interface 46. In a network environment, program modules depicted relative to the personal computer 20, or portions thereof, may be stored in the remote memory storage devices. It will be appreciated that the network connections shown are exemplary and other means of establishing a communications link between the computers may be used.

FIG. 2 illustrates an operator input device, such as mouse 40. Mouse 40 includes housing 102, electromagnetic radiation source (which may simply be a light source such as an LED) 104, aperture 106 defined in the bottom of housing 102, lens 108, image or pattern detector 110, controller 112, and current driver 114. In FIG. 2, mouse 40 is shown supported relative to work surface 116. Pattern detector 110 can be any suitable detector and may be an artificial retina pattern detector.

Light source 104 can be any suitable source of electromagnetic radiation. In one illustrative embodiment, light source 104 includes LED 118 and lens 120. Radiation emitted from an LED 118 is transmitted through lens 120 such that it passes through aperture

106 in housing 102 and impinges upon work surface 116 which has no predetermined pattern or image thereon. The light then reflects off of work surface 116 toward lens 108. Lens 108 collects the radiation reflected
5 from surface 116 and directs it to image detector (e.g., artificial retina) 110. It should be noted that lens 108 can be eliminated with the addition of lenses on either LED 118, image detector 110, or both.

Image detector 110 generates an image signal
10 indicative of an image or pattern on work surface 116. The image signal is provided to controller 112 which computes position information based on the image signal. The position information indicates movement of mouse 40 relative to work surface 116, as will be
15 described in more detail below. Position information is provided by controller 112, through an output such as a cable (not shown), to computer 20 illustrated in FIG. 1. Mouse 40 may also provide the output to
20 controller 112 through a wireless transmission link such as infrared ultrasonic, or radiofrequency links.

In the preferred embodiment, the position information provided by controller 112 is provided according to a conventional format, such as through a serial interface, a universal serial bus (USB) interface, or
25 in any other suitable interface format.

Image detector 110, in one illustrative embodiment, is an artificial retina manufactured by Mitsubishi Electric Corporation and includes a two-dimensional array of variable sensitivity photo
30 detectors (VSPDs) which operates in a known manner. Briefly, the VSPDs are formed by a side-by-side pair of diodes integrated onto and separated by a semi-insulated GaAs layer (pn-np structure). In one

embodiment, the array is a 32x32 element array, but could be larger or smaller as desired. The photo detector current depends, both in sign and magnitude, on applied voltage. Such VSPDs exhibit an analog
5 memory affect which stores conductivity information when a voltage is applied in the presence of an optical write pulse. This information is retrieved by injecting an optical readout pulse.

Image processing in such devices is based on
10 optical matrix-vector multiplication. An input image is projected onto the device as a weight matrix. All VSPDs have one electrode connected along rows, yielding a sensitivity control vector. Thus, the VSPD sensitivity can be set to arbitrary values in each row
15 within a certain range. In addition, the remaining VSPD electrode is connected along columns, yielding an output current vector defined by the matrix vector product of the weight matrix times the sensitivity control vector.

20 In an illustrative embodiment, image detector 110 is controlled to perform edge extraction operations. The sensitivities of two adjacent detector rows are set to +1 and -1, respectively, whereas all other sensitivities are set at 0. In this embodiment, the
25 output current is proportional to the difference in light intensities of the two active rows. By shifting the control voltage pattern in a cyclical manner (0, +1, -1, 0, 0, etc.), the horizontal edges of the input image are sensed. Thus, the system operates in a time
30 sequential and semi-parallel mode.

In one illustrative embodiment, mouse 40 also includes current driver 114 which is coupled to source 104. In that embodiment, controller 112

intermittently senses the intensity of the radiation generated by source 104 and adjusts the current provided to source 104 through current driver 114. In other words, if the sensed intensity is lower than a
5 desired range, controller 112 provides a feedback signal to current driver 114 to boost the current provided to source 104 in order to increase the intensity of the electromagnetic radiation emanating from source 104. If, on the other hand, the intensity
10 of the radiation is higher than a desired range, controller 112 provides the feedback signal to current driver 114 to reduce the current provided to source 104 to thereby reduce the intensity of the radiation emitted from source 104. This may be done, for
15 example, to reduce the overall power consumption of mouse 40.

FIGS. 3A-3E and 4A illustrate the operation of mouse 40 in accordance with one aspect of the present invention. FIG. 3A illustrates the 32x32 VSPD (pixel)
20 array on image detector 110, onto which the image from surface 116 is directed. The entire viewing area 123 of image detector 110 is coincident with the 32x32 pixel array. However, defined within the entire viewing area 123, is sample area 124. Sample area 124
25 is smaller than the viewing area and includes, in one illustrative embodiment, a 10 pixel by 10 pixel area centered generally around a center 126 of viewing area 123.

In operation, controller 112 first activates
30 source 104 such that radiation is impinged on work surface 116. This is indicated by block 128 in FIG. 4A. Substantially every surface has some irregularities or surface roughness, if only at the

microscopic level. A commercially available artificial retina is capable of resolving images which are only a few microns in size, assuming the light source is powerful enough. Thus, the radiation is reflected off of surface 116 back to impinge on viewing area 123, carrying with it information indicative of an image or pattern formed by the surface roughness on surface 116.

Next, a pattern on work surface 116 is identified, and source 104 is optionally deactivated.

This is indicated in blocks 130 and 134. FIG. 3B illustrates the identification of an image or pattern 132 within sample area 124 of viewing area 123. As discussed above, identification of the image can be accomplished using edge extraction or any other suitable technique. Once image 132 has been identified, data corresponding to that image is stored in memory associated with controller 112. This is indicated by block 136 in FIG. 4A.

Next, controller 112 simply waits for a predetermined time out period. The duration of the time out period determines the sampling rate of the system and thus will depend upon the maximum expected velocity of the mouse. In one illustrative embodiment, the time out duration is approximately 1-10 milliseconds. The time out period is indicated by block 138 in FIG. 4A.

After the time out period, controller 112 reactivates source 104 (if it has been deactivated), as indicated by block 140, and determines whether image 132 has moved. This is indicated by block 142.

Of course, movement of image 132 within viewing area 123 is illustrative of relative movement between mouse

40 (or at least the image detector 110 of mouse 40) and surface 116 from which the image 132 is detected.

FIG. 3C illustrates movement of image 132 from a first position, shown in FIG. 3B, to a second position, offset from the first position, and illustrated in FIG. 3C.

Based on the movement detected, controller 112 provides position information in a customary and acceptable format, at an output (such as through a cable). Such position information can be used by a computing device, such as that described with respect to FIG. 1, for any number of things, including the movement of a mouse cursor on the monitor 42. Providing the position information is indicated by block 144 in FIG. 4A.

After movement of image or pattern 132 is detected, a new image or pattern such as image 146, is detected within sample area 124 of viewing area 123. This is indicated by block 130. Light source 104 may be deactivate and image data, indicative of the new image 146, is then stored. This is indicated by blocks 134 and 136. Controller 112 then again waits for the next time out period and determines whether image 146 has moved, such as is illustrated in FIG. 3E. This process continues such that mouse 40 continues to provide position information indicative of the relative movement of mouse 40 and work surface 116.

MOVEMENT DETECTION

Detection of movement of the images in viewing area 123 can be accomplished in a number of fashions. For example, cross correlation can be used to determine movement of the image within the viewing

area 123. Cross correlation between the pattern in the sample area 124 and the pattern for the entire viewing or search area 123 is defined as follows:

Equation 1

$$R(x,y) = \int_{-\frac{L_p}{2}}^{\frac{L_p}{2}} \int_{-\frac{L_p}{2}}^{\frac{L_p}{2}} P(i,j)Q(i-x,j-y) didj$$

5

where:

L_p is the length of the sample area 124;

(i,j) is position data on the 32x32 pixel array;

10 $P(i,j)$ is the function which indicates light intensity and which corresponds to the pattern or image detected;

$Q(i,j)$ is a function indicative of light intensity over the entire viewing area 123; and

15 $R(x,y)$ is the correlation of P and Q.

This Equation can be written in the following summation form since the pattern is on the artificial retina cell array and has a quantum value over the entire length of the sample area L_p :

20

Equation 2

$$R(x,y) = K \sum_{i=-\frac{L_p}{2}}^{\frac{L_p}{2}} \sum_{j=-\frac{L_p}{2}}^{\frac{L_p}{2}} \{P(i,j)Q(i-x,j-y)\}$$

From Equation 2, it can be determined that in order to obtain movement of the image, one must obtain $P(i,j)$ first, and then after the time out period, 25 obtain $Q(i,j)$. Thereafter, the values of x and y are moved throughout the entire viewing area (or pixel

region) 123 associated with the image detector, and Equation 2 is evaluated at each point. The maximum of $R(x,y)$ will indicate the point at which the cross correlation is maximum, and will thus indicate the distance which the image has moved. In one illustrative embodiment where image detector 110 is implemented as the artificial retina chip from Mitsubishi Electric Corporation, the summation equations set out in Equation 2 can be obtained by simply summing up the current of one row in the photodetector array at a time. This is equal to one summation of Equation 2.

It should also be noted that, rather than identifying a specific shape, pattern or image in sample area 124, the entire sample area 124 can be used as the image. Then, cross correlation is simply determined between that entire image and a portion of the array on which that image resides after the time out period.

One potential disadvantage associated with the use of linear coordinates is that they provide position information which varies with rotation of mouse 42. Therefore, in another illustrative embodiment, circular harmonics are used to determine movement of the image. In that embodiment, circular coordinates r and θ are used instead of linear x,y coordinates. The circular coordinates are used to provide position information which is rotationally independent. Data representative of a sample image can be written as $P(r,\theta)$. This can be expanded by circular harmonics to:

Equation 3

$$P(r,\theta) = \sum_{m=-\infty}^{+\infty} K_m(r) e^{im\theta}$$

where,

i = the imaginary unit scalars square root of -1

and each parameter of the terms in the summation are
5 calculated as follows:

Equation 4

$$K_m(r) = \frac{1}{2\pi} \int_0^{2\pi} P(r, \theta) e^{-im\theta} d\theta$$

First, a circle of radius r is identified in the
sample area and a Fourier expansion is carried out
10 along the perimeter of the circle. Coefficients of
the calculated harmonics are stored. These steps are
repeated for that circle in the viewing area after the
time out. The coefficients are then compared to
obtain a value indicative of the direction and
15 magnitude of movement of the image.

It should be noted that Equation 3 is shown as a
sum from $-\infty$ to $+\infty$. However, the sum need only
actually be taken from zero to the size of the viewing
area. Further, equation 3 is, in one illustrative
20 embodiment, treated as a Euler function in order to
make the calculation simpler, as follows:

Equation 5

$$e^{i\theta} = \cos\theta + i\sin\theta$$

25 In another illustrative embodiment, pattern moment
characteristics are used to determine movement of the

image or pattern within the sample area. The pattern in the sample area can be represented by $P(x,y)$ wherein the sample area is a square having sides of length L_p . The pattern moment m_{pq} can be expressed as follows:

Equation 6

$$m_{pq} = \int_{-\frac{L_p}{2}}^{\frac{L_p}{2}} \int_{-\frac{L_p}{2}}^{\frac{L_p}{2}} P(x,y) x^p y^q dx dy$$

where p and q are continuous integers that can take any significant value. In general, the 0th order moment, where p, q equals 0 is given as follows:

Equation 7

$$m_{00} \iint P(x,y) dx dy$$

The 0th order moment is understood to be the total mass of the pattern data. The first order moment m_{10} , m_{01} , is given as follows:

Equation 8

$$m_{10} = \iint P(x,y) x dx dy$$

$$m_{01} = \iint P(x,y) y dx dy$$

When the first order moment is divided by the 0th order moment, the coordinates of the center of mass are obtained as follows:

Equation 9

$$\frac{m_{10}}{m_{00}} = x_c$$

$$\frac{m_{01}}{m_{00}} = y_c$$

The same process is then carried out using the
 5 second order moment, m_{20} , m_{02} to obtain the principle
 axis.

In yet another illustrative embodiment, a cord
 histogram method is used to determine movement. The
 shape of a pattern can be expressed by a cord
 10 histogram such as that shown in FIG. 3F. Only a
 single cord 152, and one angle 154 are shown in FIG.
 3F. However, each cord can be written by its length
 and angle $h(r, \theta)$. Assuming each point of pixel data
 D_{pix} on the shape perimeter is a 1, and the others are
 15 0, then the requirement of the cord is to satisfy the
 following equation.

Equation 10

$$D_{pix}(x, y)D_{pix}(x + r \cos \theta, y + r \sin \theta) = 1$$

20 The total number of cords is given as follows,
 since D_{pix} is defined to take either a 1 or a 0 value:

Equation 11

$$h(r, \theta) = \iint D_{pix}(x, y)D_{pix}(x + r \cos \theta, y + r \sin \theta) dx dy$$

25 To make the computation simpler, assume h is a
 function of r only. Then one must simply count the
 number of pixels on the shape perimeter.

Mathematically speaking, one simply sets one point on the shape as the origin, and then draws circles of radius r around the origin. The number of crossing points, of the circles crossing the perimeter, are counted. The radius is increased until there are no crossing points. The crossing points recorded become indicative of the shape of the perimeter.

DETECTING ROTATIONAL MOVEMENT

FIGS. 5 and 6A-6D illustrate another preferred embodiment in accordance with the present invention. Since conventional computer mice are often moved rotationally as well as linearly by the user, it may be desirable, in some instances, to have the detection algorithm for detecting movement of images or patterns be rotationally invariant such that they do not detect rotational movement of the mouse. However, in other embodiments, it may be desirable to have the algorithm detect rotational movement of the mouse. In those latter instances, it may be desirable to modify source 104.

In one illustrative embodiment, where detection of rotational motion is desired, lens 120 (shown in FIG. 2) is shaped to transmit radiation in an elongate, or elliptical, pattern 160, as shown in FIG. 6A. Then, if the mouse is rotated, pattern 160 moves as shown in FIG. 6B. By making the pattern elongate (e.g., elliptical) rather than simply round, this type of rotational motion can be more easily detected.

In addition, FIG. 5 illustrates another embodiment of a light source 162 which can be used in accordance with the present invention. Light source 162 actually includes two point light sources 164 and 166 (which may be LEDs and associated lenses) which

are used to transmit radiation to the surface being viewed. In that instance, the image pattern detected by image detector 110 can be used to detect the most intense points within the image. Those most intense
5 points 168 and 170 will correspond to light emitted by a region at or near the center of sources 164 and 166.

Thus, rotation of the mouse will cause rotation of points 168 and 170 as illustrated in FIG. 6B. Again, this allows rotational motion of mouse 40 to be
10 detected more easily.

FIG. 7A illustrates mouse 170 in accordance with another illustrative embodiment of the present invention. Mouse 170 has components which are similar to those shown in FIG. 2, and which are similarly
15 numbered. However, mouse 170 also includes wheel 172. In the illustrative embodiment, wheel 172 is provided on housing 102, such that the operator can rotate wheel 172 to cause additional position information to be provided from mouse 170. In the embodiment shown
20 in FIG. 7A, wheel 172 is interposed in the path of electromagnetic radiation emitted by source 104. However, wheel 172 also preferably has transparent portions thereof, such as notches or slits therein, to allow some of the radiation to impinge on surface 116.
25 One embodiment of slits 174 is illustrated in FIG. 6B, which is a side view of wheel 172. Slits 174 are shown greatly enlarged for the sake of clarity and can take any suitable dimension. Slits 174 are illustratively provided in a predetermined pattern
30 which is easily recognizable by image detector 110 and controller 112. However, slits 174 provide a rather large transparent area such that radiation can be emitted through the transparent area, onto surface

116, and then be reflected to image detector 110. In that way, image detector 110 and controller 112 can obtain signals indicative of images from surface 116, and can also detect and monitor rotational movement of wheel 172.

For example, FIG. 8A illustrates a pattern on viewing area 123 caused by slits 174. As in FIGS. 3A-3E, viewing area 123 includes sample area 124 within which patterns are identified, and from which movement of the patterns is determined. However, viewing area 123 also includes a predetermined pattern 176 superimposed thereon because the radiation travels only through the transparent portions of notches 174. As wheel 172 is rotated, the superimposed pattern 176 migrates across viewing area 123. For example, if wheel 172 is slightly rotated, then the pattern 176 superimposed on viewing area 123 migrates such as shown in FIG. 8B.

Of course, slits of other shapes could be used as well. For example, FIGS. 8C and 8D illustrate that slits 174 can be simply rectangular slits. In that case, pattern 178 is superimposed on viewing area 123. Then, with rotation of wheel 172, the pattern migrates across viewing area 123 as illustrated in FIG. 8B. This allows image detector 110 and controller 112 to provide position information which not only reflects movement of mouse 40 relative to surface 116, but which is also indicative of movement of wheel 172 (or the surface of wheel 172) relative to image detector 110 and light surface 104. This can all be done without traditional position encoders and associated circuitry and without hardware which is used in prior, conventional user input devices.

FIG. 9A is a block diagram illustration of a portion of a user input device (such as a mouse) 180.

Mouse 180 is similar to mouse 170 shown in FIG. 7A, and similar items are similarly numbered. For the sake of clarity, wheel 172 has been moved from the position shown in FIG. 7A, and a number of the items shown in FIG. 7A have not been shown in FIG. 9A. Mouse 180 not only includes LED 104, but preferably includes two additional sources of electromagnetic radiation, such as LEDs 182 and 184. Further, mouse 180 includes a plurality of light pipes 186 and 188. Each of light pipes 186 and 188 may be formed of a single integral member, or of plurality of members coupled to one another to form the appropriate light path.

In operation, LED 104, lens 108 and image detector 110 operate in a similar fashion to that described above, with respect to an image located on surface 116. However, in accordance with another preferred embodiment, wheel 172 is provided with a plurality of darkened areas 192 spaced about the periphery thereof (as indicated in FIG. 9E). LED 182 is configured to emit radiation which impinges on an area proximate darkened regions 192 on wheel 172. As wheel 172 is rotated, the alternating darkened regions, and light regions 191 which reside between the darker regions 192, reflect the radiation emitted by LED 182. Light pipe 188 is configured to receive the radiation reflected by wheel 172 and direct that radiation onto a prespecified portion 194 of image detector 110. Since darkened portions 190 are separated by lighter portions 191, as wheel 170 is rotated, the intensity of reflected light, reflected

from wheel 172 through light pipe 88, will change. Therefore, controller 112 (shown in FIG. 7A) is configured to examine the prespecified area 194 on image detector 110 to determine the intensity of the light impinging on that area in order to determine whether wheel 172 has rotated, or is being rotated.

Similarly, mouse 180 includes actuator button 196. Actuator button 196 is preferably a conventionally arranged press button which can be depressed by the user in order to perform an actuation operation. Thus, actuation button 196 is shown pivotally movable about pivot point 198 in the direction indicated by arrow 200. In one preferred embodiment, actuation button 196 includes a depending surface 202. LED 184 is configured to direct radiation emitted therefrom into light pipe 86, which directs that radiation to a second prespecified portion 204 of image detector 110.

As actuation button 196 is depressed, surface 202 moves downward to interrupt the emanation of radiation from LED 184 to light pipe 86. In one preferred embodiment, surface 202 is either opaque, or is formed of a filter material which filters a portion of the radiation emitted by LED 184. Thus, when actuator button 196 is depressed, the intensity of light emitted on prespecified portion 204 of image detector 110 decreases relative to the intensity which impinges on that region when actuator button 196 is not depressed.

Therefore, controller 112 is preferably arranged to intermittently examine prespecified portions 194 and 204 to determine whether wheel 172 is being rotated, and also to determine whether actuation

button 196 is depressed.

It should be noted that, in some current operator input devices, wheel 172 can also operate as an actuation button, and can be depressible in much the same way as actuation button 196. Thus, a similar configuration can be provided to detect the depression (or actuation) of wheel 172. It should also be noted that, rather than providing darkened portions 190 on wheel 172, those portions could be transparent portions. Thus, the amount of light reflected from wheel 190 would decrease when LED 182 impinges upon one of the transparent areas.

FIG. 9B illustrates a viewing area 123 and sample area 124. FIG. 9B also illustrates the prespecified areas 194 and 204 on viewing area 123 which are used to detect rotation of wheel 172 and actuation of button 196. Of course, it should be noted that any number of prespecified areas can be provided on viewing area 123, so long as there is also sufficient remaining area to detect movement of objects on surface 116.

Other methods could be used to detect movement relative to surface 116, rotation and depression of wheel 172 and depression of actuation button 196. For example, if a specified section of viewing area 123 is not available, then a histogram algorithm can be used to detect light added by rotation or depression of wheel 172, and by depression of actuator button 196.

Light pipes 186 and 188 are then repositioned to direct the radiation conducted thereby such that it impinges upon the entire viewing area 123 of image detector 110. Thus, the overall intensity of the radiation impinging on viewing area 123 increases as

the light reflected from wheel 172, and the light provided by LED 184, increases.

FIG. 9C illustrates a graph 206 which plots a signal indicative of intensity (such as voltage) against position on viewing area 123. FIG. 9C illustrates that, in the embodiment in which image detector 110 is an artificial retina, the output is an analog signal which varies over the viewing area. FIG. 9C illustrates three waveforms, 208, 210 and 212. Waveform 208 is a general depiction of an example of a waveform provided by image detector 110 which is indicative of the image on surface 116 within viewing area 123. Waveform 208 has a baseline intensity and varies with variation in the image along viewing area 123. The peaks and troughs in the signal correspond to different portions of the image on viewing area 123.

Waveform 210 illustrates the same waveform as waveform 208, but with wheel 172 rotated to a position which causes a larger amount of light to be reflected therefrom through light pipe 188 onto the entire viewing area 123. In that case, waveform 210 still represents the image detected on surface 116, by its shape. However, an offset 214 exists relative to waveform 208. Thus, controller 112 can be configured to detect offset 214 and interpret that to mean that wheel 172 has been rotated to a position in which more light is being reflected therefrom.

Similarly, waveform 212 illustrates the same waveform as waveforms 208 and 210, but which also includes an offset 216 from waveform 210. Waveform 212 corresponds to a waveform in which wheel 172 is at a position where it reflects a larger amount of light,

and also where actuator button 196 is at a position such that it does not impinge upon the radiation emitted from LED 184 to light pipe 186. Since, in the embodiment currently being discussed, light pipe 186
5 is arranged to emit radiation over the whole viewing area 123, controller 212 can be configured to detect offset 216 and interpret that as meaning that actuation button 196 is in the undepressed position.

In one preferred embodiment, offsets 214 and 216
10 are of a different magnitude such that controller 112 can distinguish between the two offsets, and thus determine which event is being indicated by the given offset.

FIG. 9D illustrates yet another technique for
15 detecting the various events which can take place in mouse 180. In the embodiment illustrated by FIG. 9D, LEDs 104, 182 and 184 preferably emit different wavelength radiation. Since an artificial retina image detector provides an analog output signal, the
20 signal received at the output of the array can be filtered to isolate various frequency components of the signal. FIG. 9D illustrates a plot of a signal indicative of intensity (such as voltage) provided by image detector 110 plotted against frequency. If the
25 output signal of image detector 110 is filtered and subjected to threshold detection, the levels of intensity at various radiation frequencies can be isolated to provide an indication of which event is then taking place in mouse 180. For example, FIG. 9D
30 shows four frequencies, f_1 , f_2 , f_3 , and f_4 . Assuming that frequencies f_1 - f_3 correspond to the frequencies of radiation emitted by LEDs 104, 182 and 184, controller 112 can determine, based upon the intensity

of radiation received at those frequency levels, whether wheel 172 is being rotated or depressed, and whether actuation button 196 is being depressed.

In another embodiment, the LEDs 104, 182 and 184
5 can be activated in a cyclical fashion. This cycling is synchronized to the signal provided by image detector 110 and controller can determine which event is occurring, based on the intensity and the sampled time period.

10 FIG. 10A illustrates mouse 180 with one modification from that shown in FIG. 9A. Rather than providing separate discrete LEDs 104, 182 and 184, mouse 180 shown in FIG. 10A provides only a single LED 104, with a plurality of light pipes 215, 217 and 219
15 directing a portion of the radiation emitted by LED 104 to the specific positions illustrated. Thus, the separate sources of electromagnetic radiation need not be provided.

FIG. 10B illustrates another method of detecting
20 various events in mouse 180. FIG. 10B shows that prespecified portions 194, 204, 218 and 220 are not arranged along the top of viewing area 123, as illustrated by FIG. 9B, but are instead arranged in the corners of viewing area 123. This can be
25 accomplished, in one preferred embodiment, by providing light pipes 186 and 188 (in FIG. 9A) or light pipes 215, 217, and 219 (in FIG. 10A) and any other desired number of light pipes, and arranging those light pipes such that light emitted thereby is
30 directed onto the prespecified areas 194, 204, 218 and 220.

FIG. 11A illustrates another embodiment of an input device 224 in accordance with another aspect of

the present invention. A number of items of input device 224 are similar to those shown in FIG. 7A, and are similarly numbered. However, for the sake of clarity, current driver 114 and controller 112 have
5 been eliminated from FIG. 11A. Elements are also slightly rearranged in FIG. 11A relative to those shown in FIG. 7A, again for the sake of clarity. For example, LED 104 is still arranged to impinge radiation on surface 116. However, lens 108 and image
10 detector 110 are arranged such that the radiation reflected from surface 116 is reflected upwardly to engage mirror element 226. Mirror element 226 redirects the radiation back down onto lens 108 where it is collected and transmitted to image detector 110.

15 Input device 224 also includes a second LED 228 and a track ball 230. Track ball 230 is preferably mounted to housing 102 in a conventional manner such that it is rotatable relative to housing 102 in all directions.

20 LED 228 is arranged to emit radiation which impinges on the surface of track ball 230. The light reflected from the surface of track ball 230 is reflected onto lens 108. Controller 112 (not shown in FIG. 11A) is preferably configured to switch between
25 actuation of LED 104 and LED 228, either as desired by the user or in a cyclical fashion mentioned above.

It can thus be seen that, when LED 104 is actuated, user input device 224 can be used as a conventional mouse and moved relative to surface 116.
30 Controller 112 then provides position information which is indicative of the movement of mouse 224 relative to surface 116. However, when LED 228 is activated, user input device 224 can be used much the

same as a conventional track ball input device. The user simply rotates track ball 230 and images on the surface of track ball 230 are detected by image detector 110. Since the device image detector is surface independent, the mouse ball does not need any specific patterns to be imprinted on the mouseball surface. Controller 110 thus provides position information which is indicative of the rotation of track ball 230.

10 It should also be noted that, in a preferred embodiment, an optional opaque separator element 232 can be placed to separate the radiation which impinges on lens 108 and image detector 110. In that embodiment, image detector 110 is separated into two image detector areas 234 and 236, as indicated in FIG. 11B. Thus, both LEDs 104 and 228 can be actuated at the same time, and controller 112 can provide combined or separated position information indicative not only of the movement of user input device 224 relative to surface 116, but also indicative of the user's movement of track ball 230. This turns user input device 224 into a four-degree of freedom device.

FIG. 12A is a block diagram of a portion of a user input device 250 in accordance with another aspect of the present invention. A number of items shown in FIG. 12A are similar to those shown in previous figures, and are similarly numbered. However, FIG. 12A illustrates that user input device 250 includes mode switch 252, shaft 254 coupled to wheel 172, detent wheel 256 and detent blocker 258. FIG. 12A also illustrates that controller 112, in one preferred embodiment, includes variable resistor 260, analog-to-digital (A/D) converter 262 and microprocessor 264.

In one preferred embodiment, detent wheel 256 is fixedly coupled to wheel 172 by shaft 254. Detent wheel 256 also preferably includes a plurality of detents 266 on its outer periphery. Thus, as wheel 172 rotates, detent wheel 256 is also driven through rotation by shaft 254.

Detent blocker 258, in one preferred embodiment, is a resilient element which engages detents 266 on detent wheel 256. Therefore, as the user rotates wheel 172, detents 266 rotate causing corresponding deflection of detent blocker 258. The resilience of detent blocker 258 provides the user with a tactile feedback corresponding to rotation of wheel 172.

Also, in one preferred embodiment, it may be desirable to allow wheel 172 to act as a free wheel, without tactile detent feedback. Thus, device 250 is provided with mode switch 252. User actuation of mode switch 252 causes detent blocker 258 to be retracted out of engagement with detents 266 on detent wheel 256. This can be accomplished using any suitable mechanism or other configuration. In that configuration, wheel 172 can be freely rotated by the user, as a free wheel, without any tactile feedback.

It should also be noted that the same free wheel configuration can be obtained using a clutch mechanism (not shown). In such a clutch mechanism, a first clutch surface (or clutch wheel) is rigidly attached to wheel 172 and has a detent wheel engaging surface facing detent wheel 256. Detent wheel 256 is preferably movable toward, and away from, the clutch wheel. In order to engage the clutch, detent wheel 256 is moved toward the clutch wheel such that a mating surface or detent wheel 256 comes into

engagement with the clutch wheel thereby causing detent wheel 256 to rotate with wheel 172. To disengage the clutch, of course, detent wheel 256 is moved out of engagement with the clutch wheel and
5 therefore does not turn with wheel 172, allowing wheel 172 to turn as a free wheel.

FIG. 12A also illustrates controller 112 in greater detail. The analog output of image detector 110, in one preferred embodiment, is fed into variable
10 resistor 260. The output of variable 260 is, in turn, provided to A/D converter 262. A/D converter 262 provides a digital output which is indicative of the input received from variable resistor (or force sensitive resistor) 260. Microprocessor 264 receives
15 the digital output for further processing.

FIG. 12B illustrates a waveform 266 indicative of an input to A/D converter 262. During normal operation, the analog output signal from image detector 110 varies based upon the intensity of light
20 impinging thereon. If, in the example illustrated, wheel 172 is continuously rotated such that darkened regions 190 on wheel 172 are continuously passing through the radiation emitted by LED 104, the output from image detector 110, in one preferred embodiment,
25 is a continuously varying analog signal, such as a sinewave signal indicated by sine wave 266. The amplitude of the signal is reduced after passing through variable resistor 260 and is provided to A/D converter 262.

30 In the configuration illustrated in FIG. 12A, deflection of detent blocker 268 under the force of detents 266 causes variable resistor 260 to change values. This results in the magnitude of the signal

provided from variable resistor 260 to A/D converter 262 to also vary, in a corresponding manner. In one preferred embodiment, deflection of detent blocker 258 under the force of one of detents 266 causes the
5 resistance of variable resistor 260 to be reduced. This results in a corresponding increase in the magnitude of the signal provided to A/D converter 262.

In FIG. 12B, this corresponds to a higher magnitude signal 268 reaching A/D converter 262 with each
10 deflection of detent blocker 258. Thus, the output of A/D converter 262 includes a digital value which varies as the magnitude of waveform 266 varies. Microprocessor 264 can then detect not only the direction and rate at which wheel 172 is being
15 rotated, but it can also detect the number of detents or notches through which wheel 172 is rotated. This allows microprocessor 264 to obtain rate information, as well the detent information, from the signal.

It should be noted that the present invention can
20 also be used with other user input configurations, such as joysticks. The present invention operates without a predetermined pattern on the surface and without expensive charge coupled devices. It should also be noted that the overall viewing area is
25 preferably approximately 10mm x 10mm. Any suitable area can be used. However, it has been found that an appropriate lens for focusing on a much smaller area is more expensive. It should be further noted that the solid state artificial retina image detector 110
30 can be combined on the same die as controller 112.

Thus, the present invention provides a user input device which is capable of detecting movement of the user input device relative to one or more surfaces

(when the surface is a work surface such as surface 116, or a surface of a movable apparatus mounted on the user input device such as a wheel or a track ball or an actuator button). The surface need have no
5 predetermined pattern thereon. This is done through detection of images or patterns, and monitoring of movement of the detected images or patterns on the surface relative to the user input device. Thus, this is done without conventional position encoders and
10 without expensive charge coupled devices. Further, the present invention provides a number of different algorithms for detecting movement of the identified pattern, provides feedback to adjust the intensity of the source of electromagnetic radiation, and also
15 provides power saving techniques to reduce power consumed by the user input device.

Although the present invention has been described with reference to preferred embodiments, workers skilled in the art will recognize that changes may be
20 made in form and detail without departing from the spirit and scope of the invention.

WHAT IS CLAIMED IS:

1. An operator input device configured to provide position information based on relative movement of a surface and the operator input device, the position information being provided to control movement of a visual image on a visual display screen of a computing device, the operator input device comprising:

a housing;

a pattern independent image detector coupled to the housing and being configured to detect a first pattern on the surface and provide a pattern signal corresponding to the first pattern detected; and

a controller coupled to the pattern detector and configured to receive the pattern signal and provide the position information based on a position of the first pattern relative to the pattern detector.

2. The operator input device of claim 1 wherein the controller is configured to determine a position of the first pattern relative to the pattern detector and provide the position information based on movement of the first pattern from the position.

3. The operator input device of claim 2 wherein the controller is configured to detect a second pattern and a position of the second pattern relative to the pattern detector, after movement of the first pattern, and to provide the position information based on movement of the second pattern from the position

-35-

4. The operator input device of claim 1 wherein the housing includes an aperture and wherein the pattern detector is arranged to detect the first pattern on a work surface, through the aperture.
5. The operator input device of claim 1 and further comprising:
 - a movable element mounted to the housing and wherein the surface is disposed on the movable element.
6. The operator input device of claim 5 wherein the movable element comprises:
 - a track ball rotatably mounted to the housing.
7. The operator input device of claim 5 wherein the movable element includes a rotatable wheel mounted for rotation relative to the housing.
8. The operator input device of claim 5 wherein the movable element comprises an actuator button movably mounted to the housing.
9. The operator input device of claim 5 wherein the housing includes an aperture and wherein the pattern detector is configured to detect the first pattern on a work surface, through the aperture, and to detect a second pattern on the surface of the movable element.
10. The operator input device of claim 1 wherein the pattern detector comprises:
 - a source of electromagnetic radiation.

-36-

11. The operator input device of claim 10 wherein the pattern detector comprises:

an image sensor array arranged to receive radiation carrying pattern information about the surface.

12. The operator input device of claim 11 wherein the pattern detector comprises:

an artificial retina arranged to receive radiation carrying pattern information about the surface.

13. The operator input device of claim 10 and further comprising:

a driver, coupled to the source of electromagnetic radiation, providing a driving signal to drive the source of electromagnetic radiation; and wherein the controller is coupled to the driver and is configured to detect intensity of the source of electromagnetic radiation and provide a feedback signal to the driver based on the intensity detected to adjust the intensity.

14. The operator input device of claim 13 wherein the controller is configured to determine whether the intensity detected is within a desired range and adjust the feedback signal to the driver based on the determination.

15. The operator input device of claim 10 wherein the

-37-

controller is coupled to the source of electromagnetic radiation and is configured to only intermittently actuate the source of electromagnetic radiation.

16. The operator input device of claim 10 wherein the source of electromagnetic radiation is configured to radiate electromagnetic radiation in an elongate pattern.

17. The operator input device of claim 10 wherein the source of electromagnetic radiation includes a plurality of point light sources.

18. The operator input device of claim 9 wherein the pattern detector further includes:

- a plurality of light pipes directing electromagnetic energy from the source to a plurality of surfaces; and
- a detection device; and
- a second plurality of light pipes, the second plurality of light pipes directing electromagnetic energy reflected from the plurality of surfaces to the detection device.

19. A method of providing information for controlling movement of a visual image on a display screen of a computing device, the method comprising:

- providing an operator input element movable relative to a surface;
- detecting a pattern on the surface;
- detecting relative movement of the operator input element and the pattern on the surface; and

-38-

providing position information indicative of the relative movement detected.

20. The method of claim 19 wherein detecting relative movement comprises:

detecting a first position of the pattern; and
detecting movement of the pattern from the first position.

21. The method of claim 20 wherein detecting movement of the pattern from the first position comprises:

detecting a distance of movement of the pattern from the first position.

22. The method of claim 20 wherein detecting movement of the pattern from the first position comprises:

detecting a speed of movement of the pattern from the first position.

23. The method of claim 19 wherein detecting a pattern on the surface comprises:

impinging electromagnetic radiation on the surface; and
detecting electromagnetic radiation carrying information indicative of the pattern on the surface.

24. The method of claim 23 and further comprising:
extracting the pattern from the electromagnetic radiation detected.

25. The method of claim 22 and further comprising:
intermittently detecting an intensity of the

electromagnetic radiation; and
adjusting the intensity detected based on a
desired intensity range.

26. The method of claim 24 wherein extracting the
pattern comprises:

detecting rotational movement of the pattern.

27. The method of claim 26 wherein impinging
electromagnetic radiation comprises:

impinging the electromagnetic radiation in an
elongate pattern.

28. The method of claim 26 wherein impinging
electromagnetic radiation comprises:

impinging the electromagnetic radiation with a
plurality of separated radiation sources.

1/13

FIG. 1

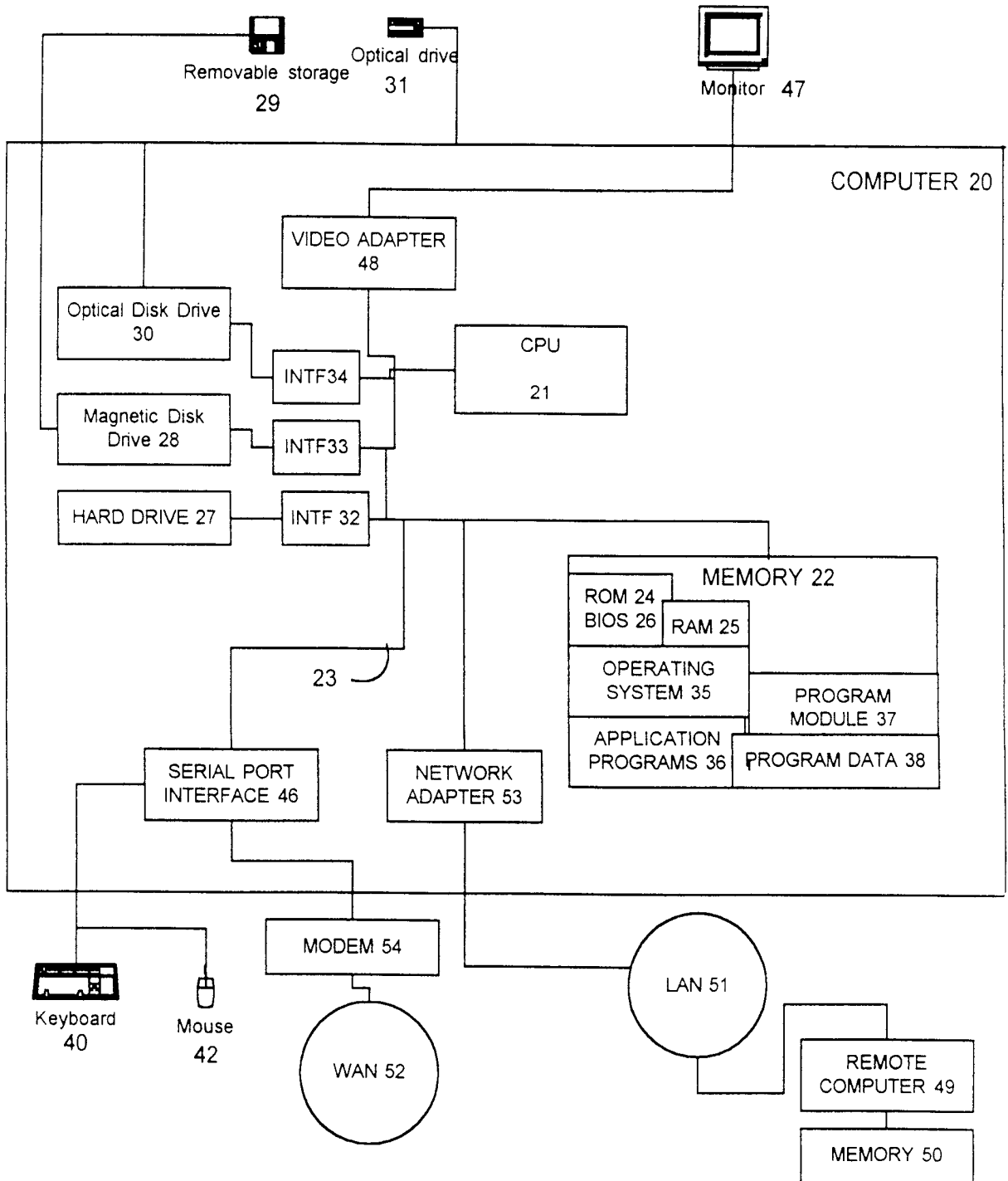

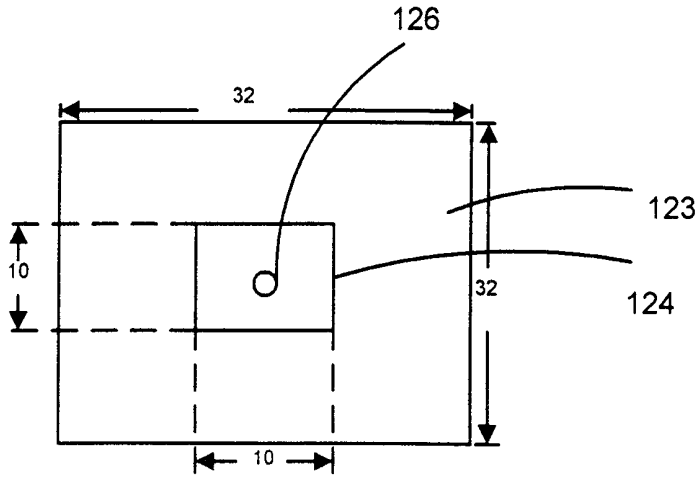

FIG. 3A

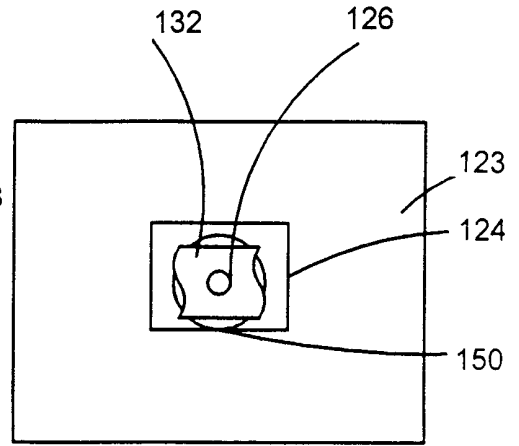

FIG. 3B

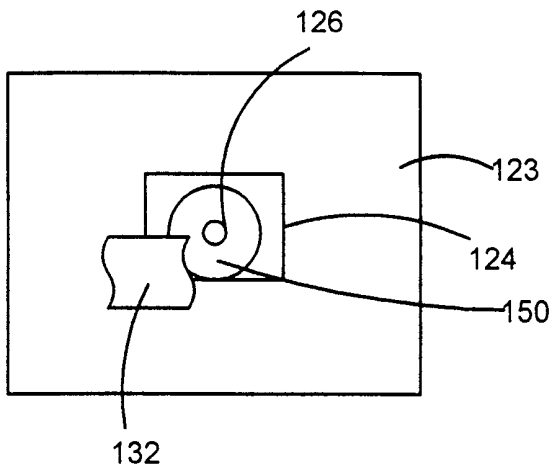

FIG. 3C

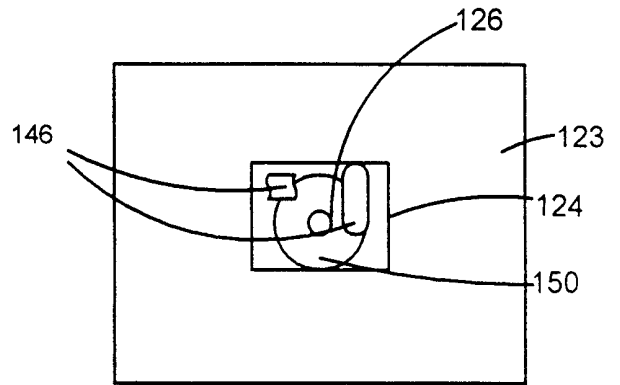

FIG. 3D

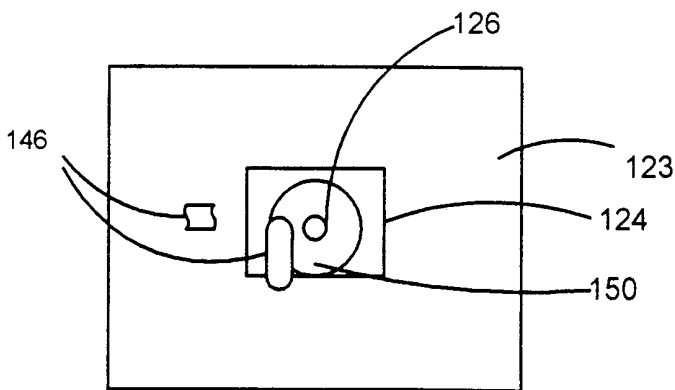

FIG. 3E

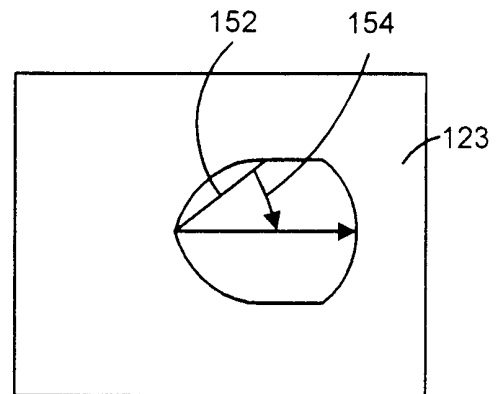

FIG. 3F

4/13

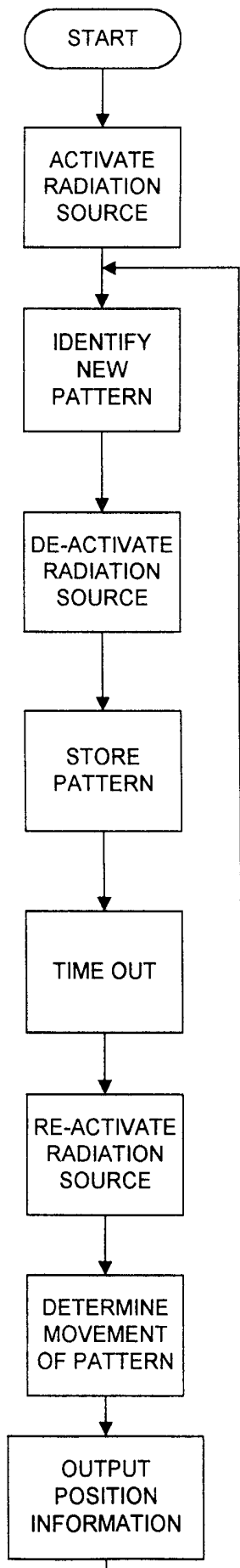

FIG. 4A

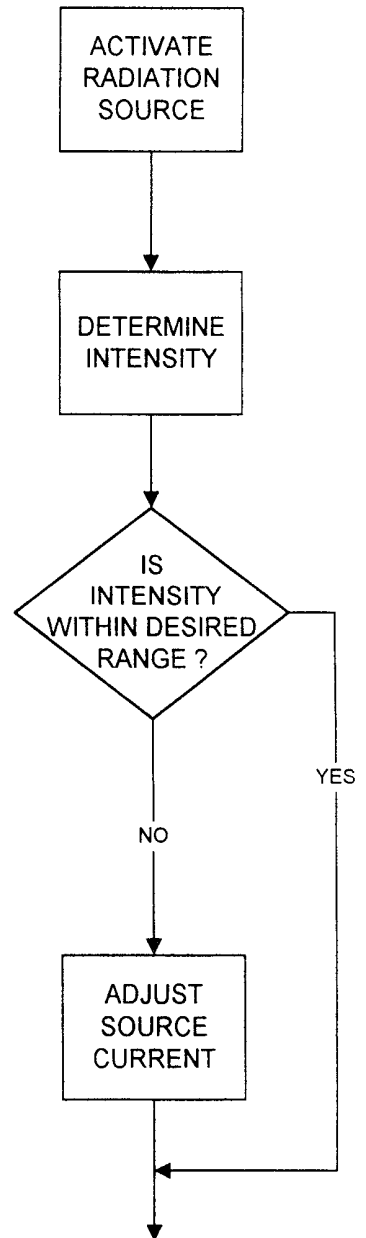

FIG. 4B

5/13

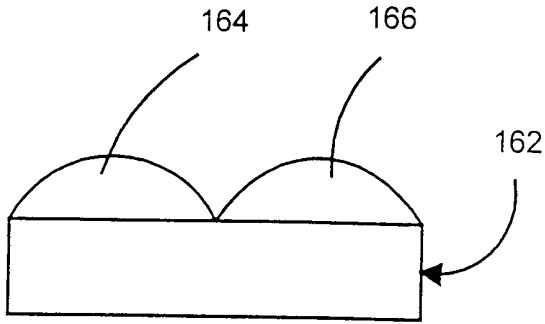

FIG. 5

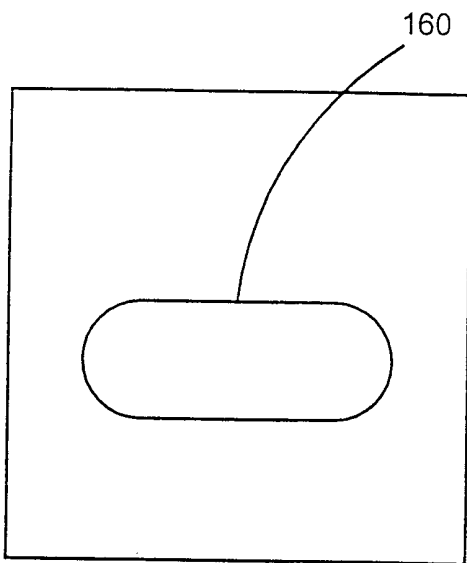

FIG. 6A

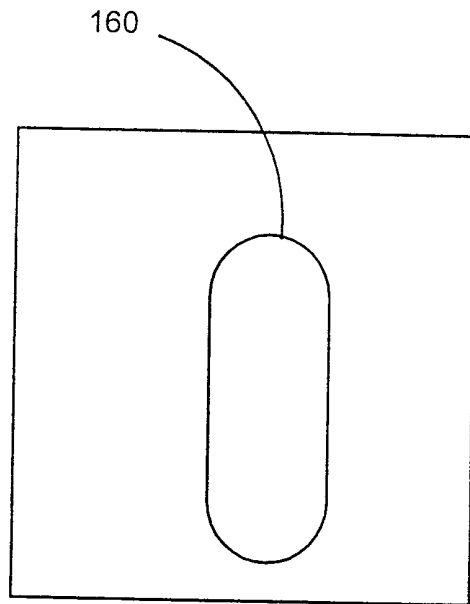

FIG. 6B

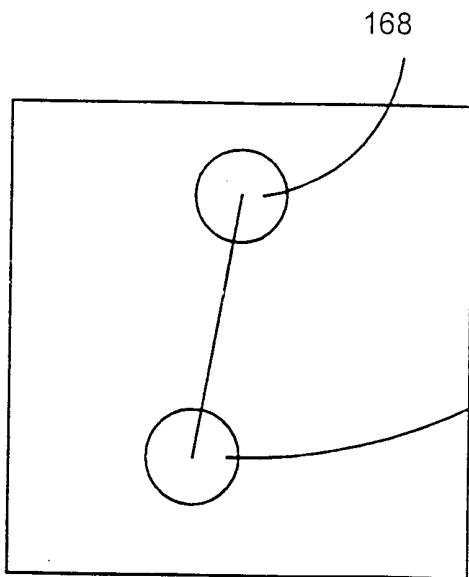

FIG. 6C

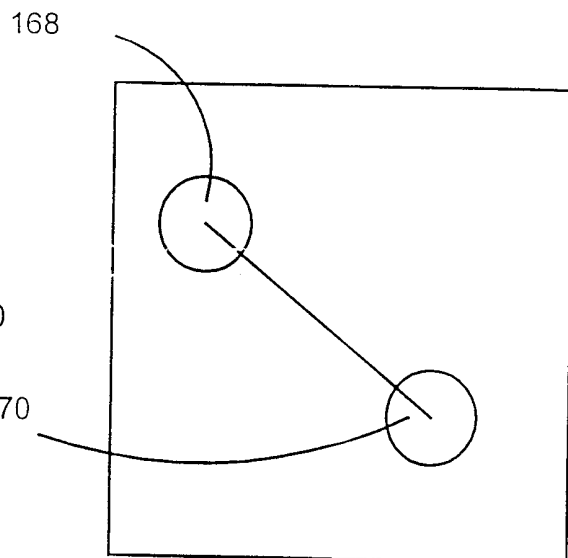

FIG. 6D

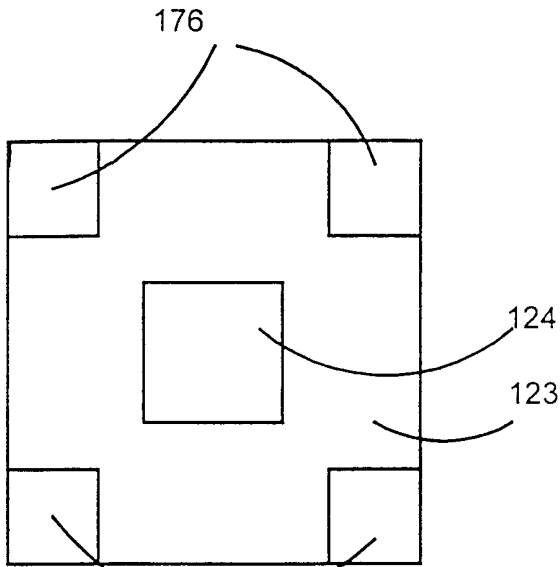

FIG. 8A

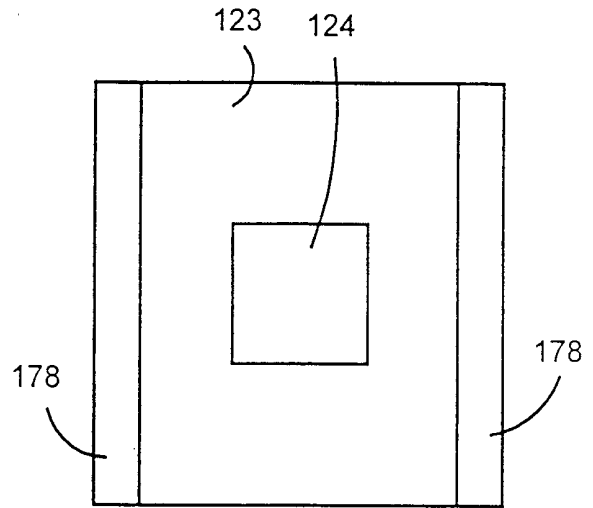

FIG. 8C

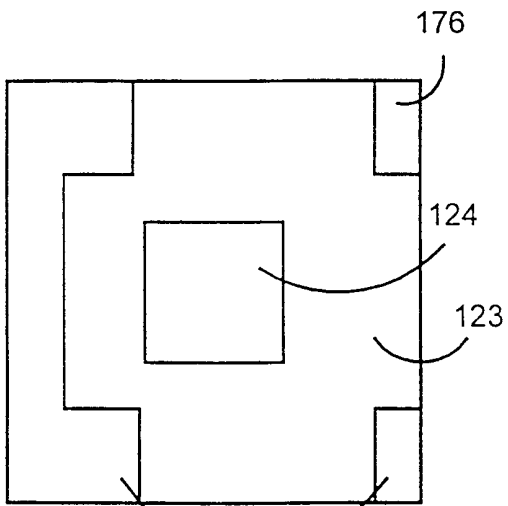

FIG. 8B

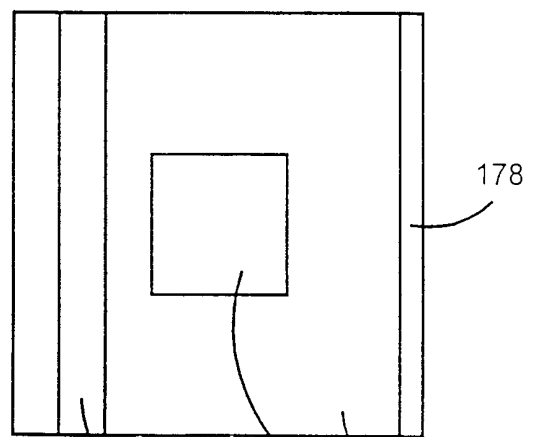

FIG. 8D

8/13

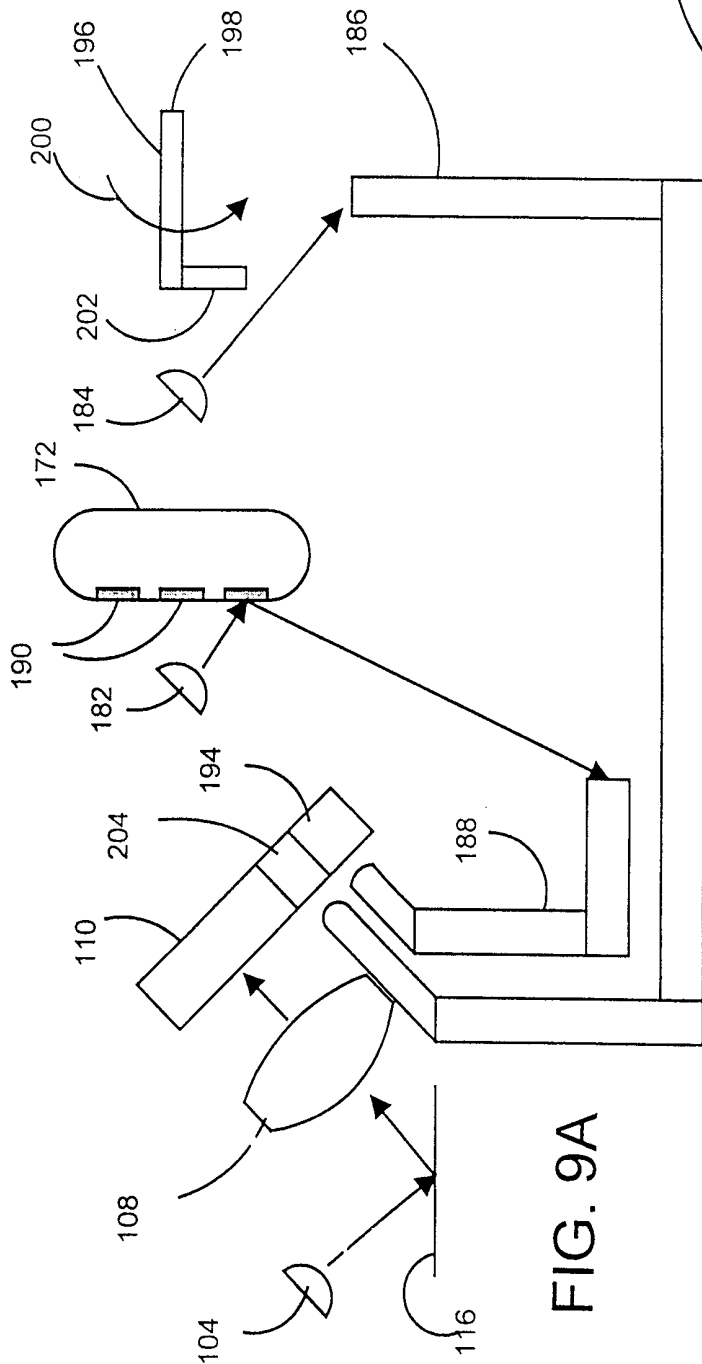

FIG. 9A

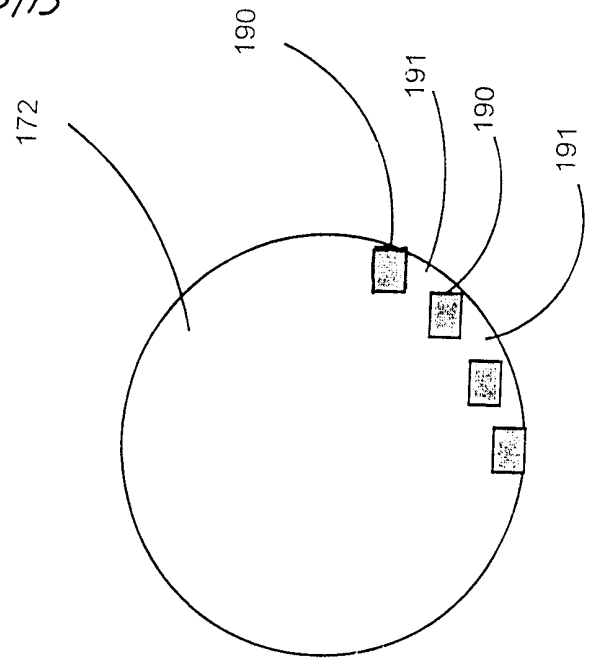

FIG. 9E

9/13

FIG. 9C

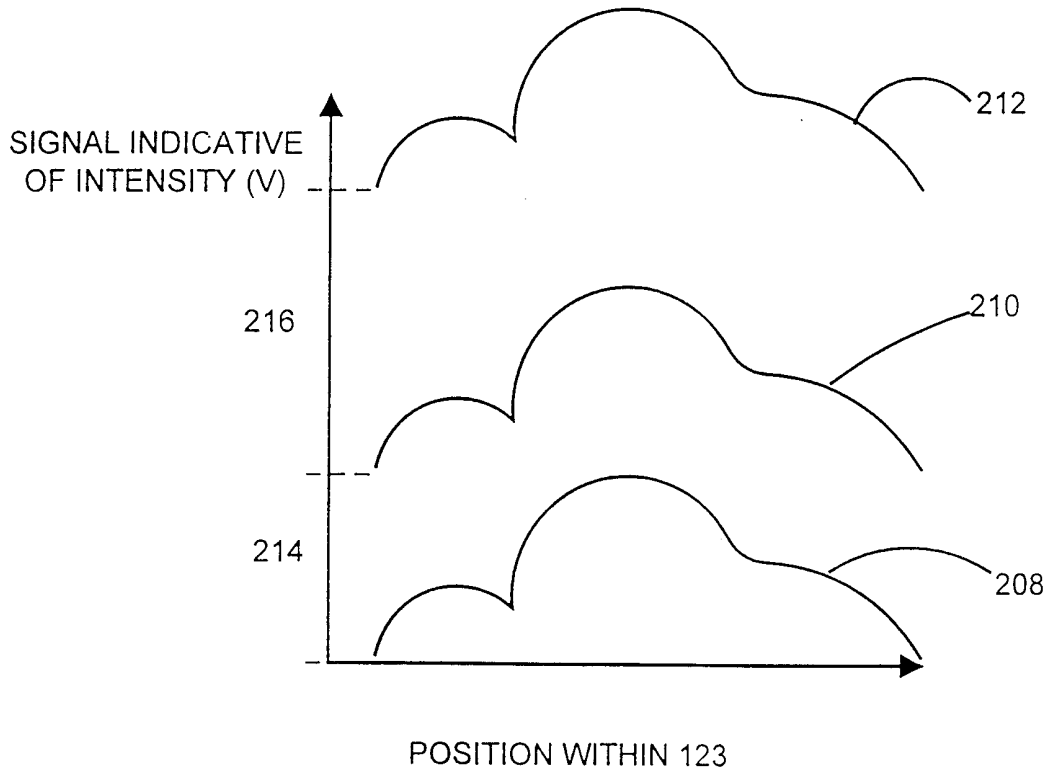
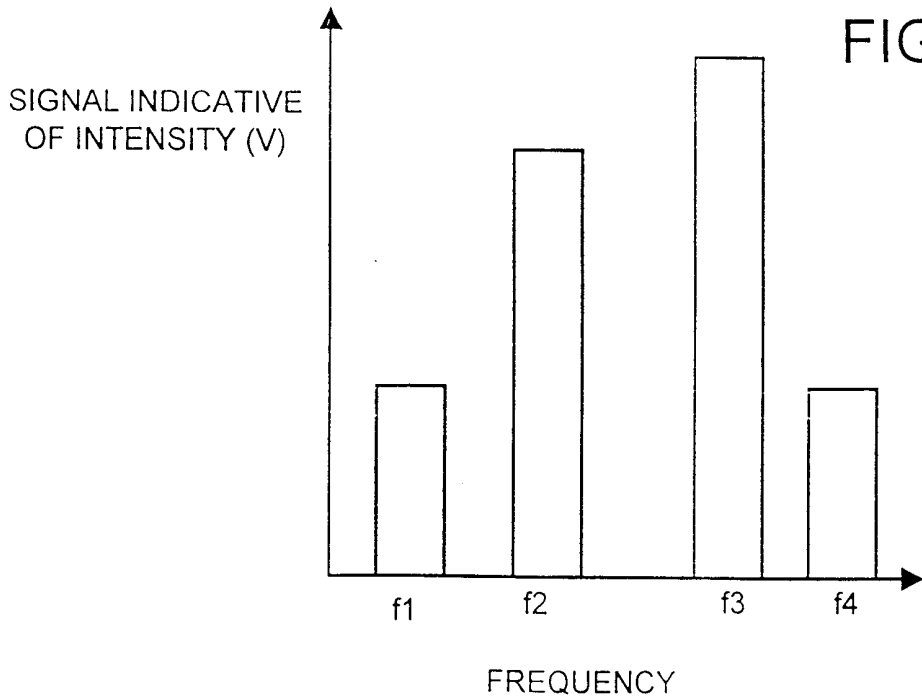

FIG. 9D



10/13

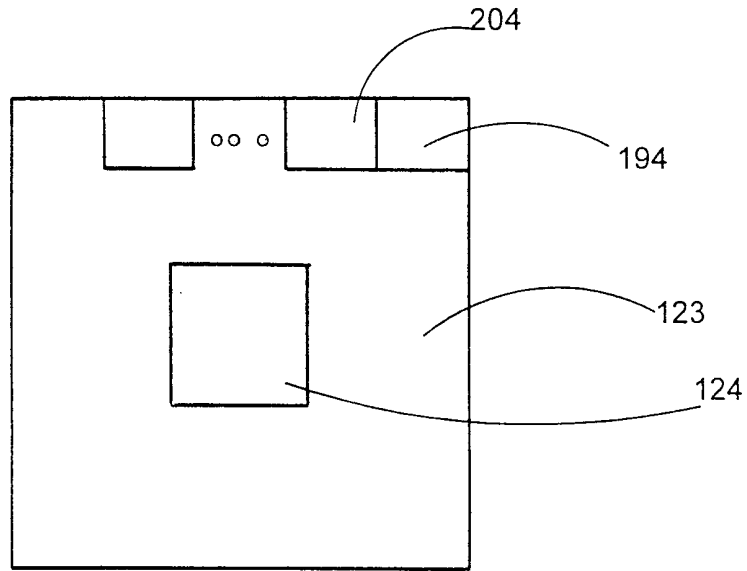

FIG. 9B

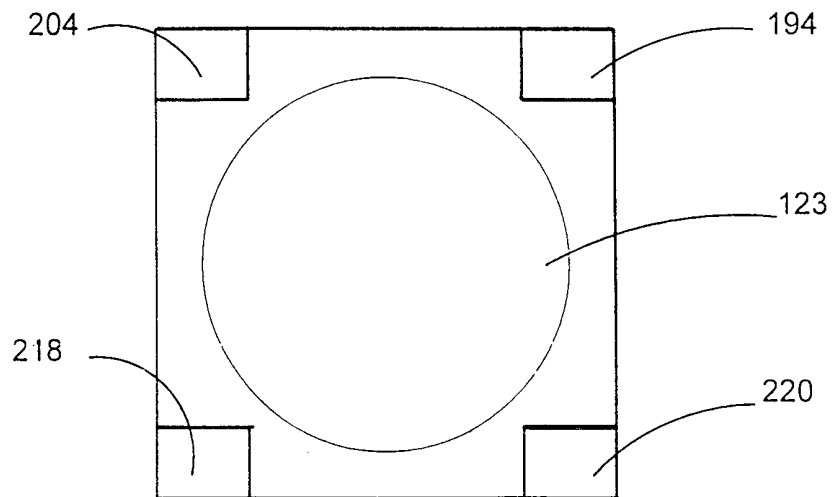

FIG. 10B

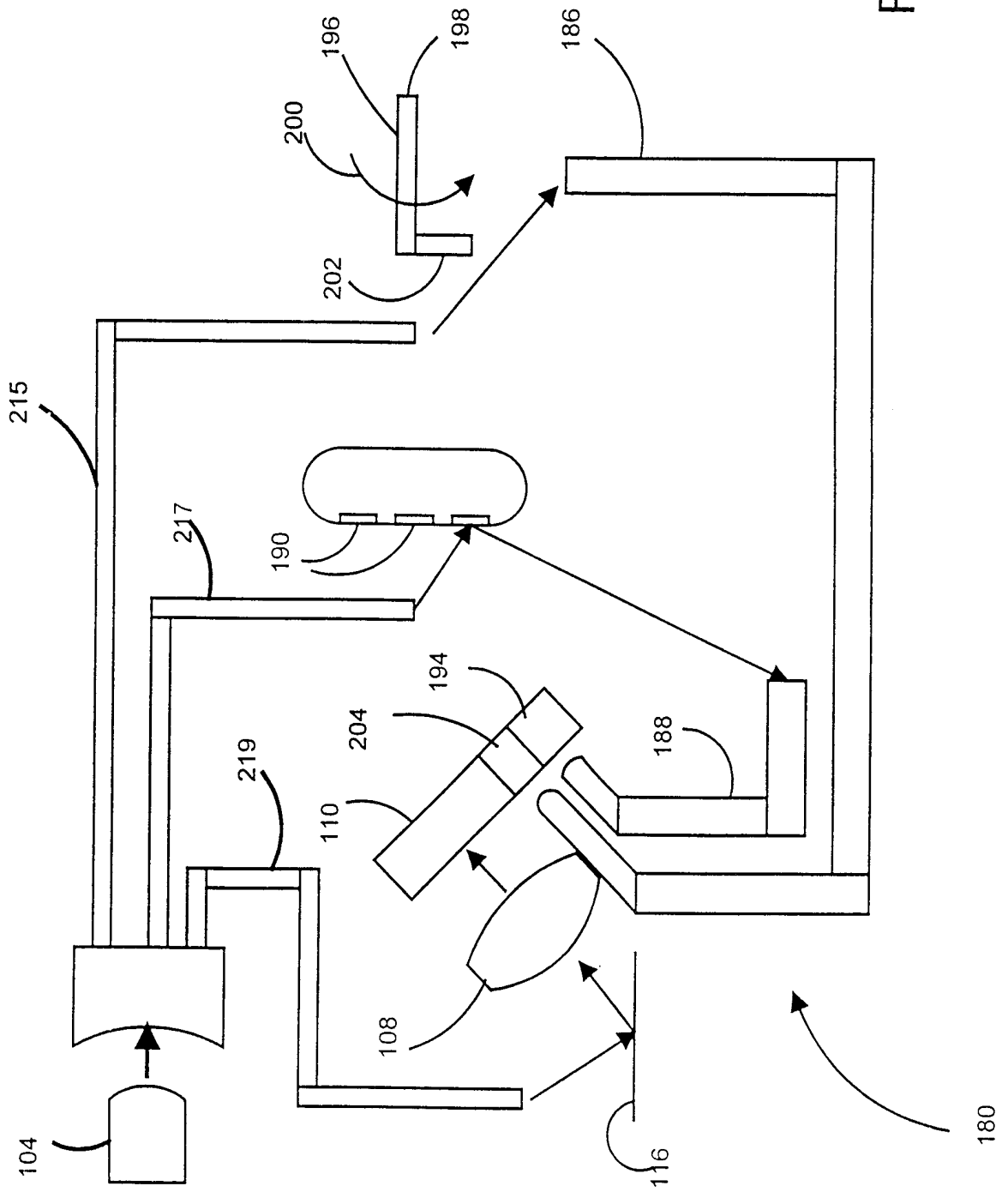

FIG. 10A

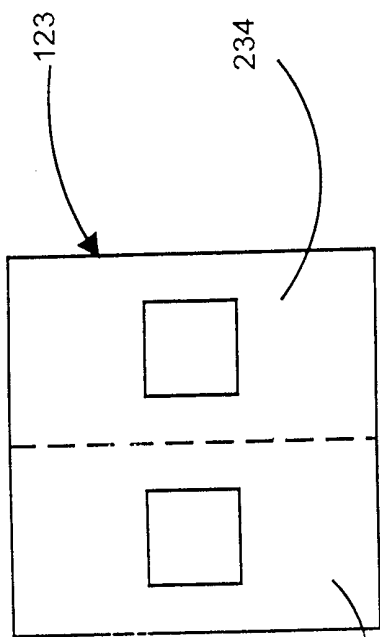

FIG. 111B

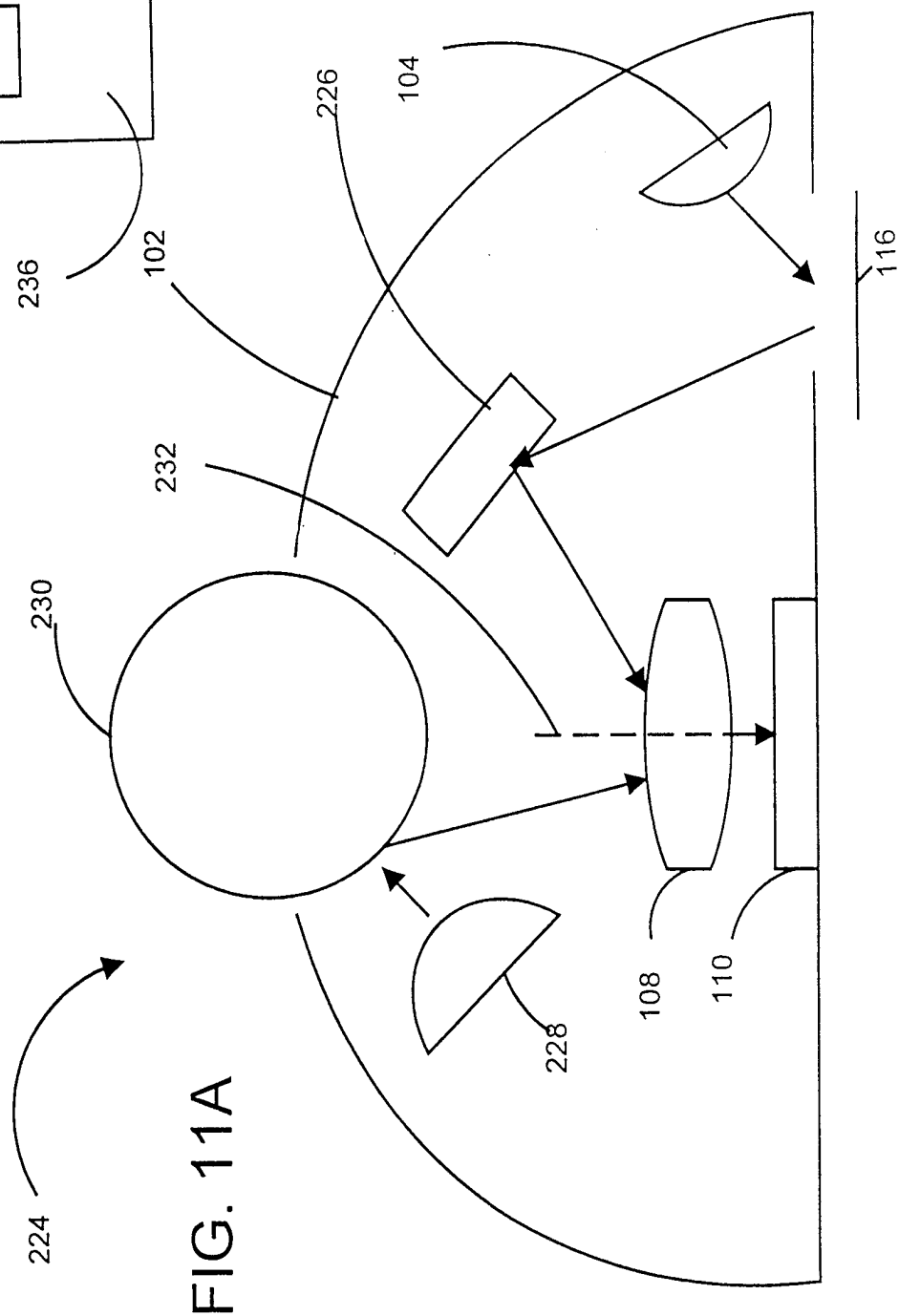

FIG. 111A

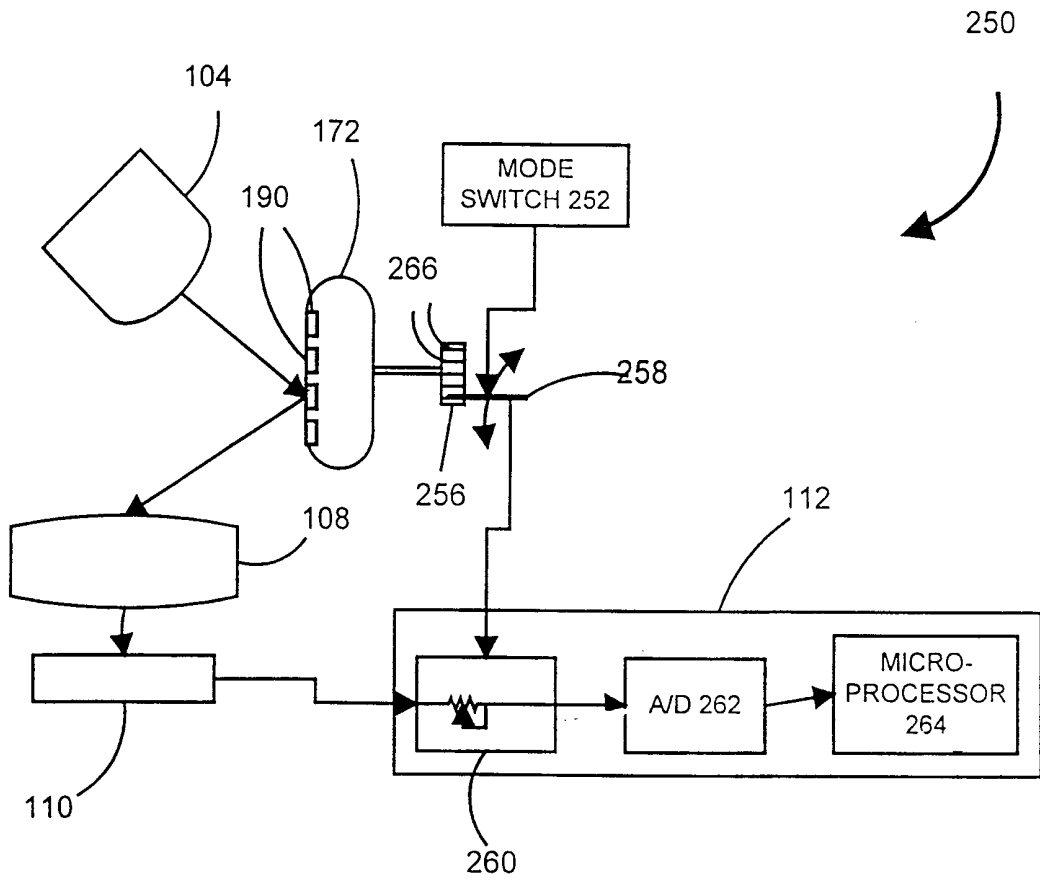

FIG. 12A

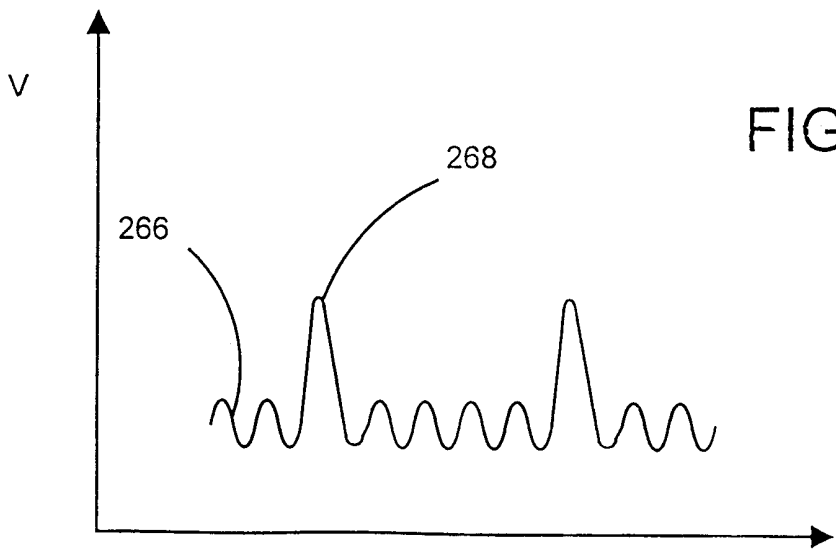

FIG. 12B

INTERNATIONAL SEARCH REPORT

Inter. onal Application No

PCT/US 99/01706

A. CLASSIFICATION OF SUBJECT MATTER IPC 6 G06K11/08 G06K11/18		
According to International Patent Classification (IPC) or to both national classification and IPC		
B. FIELDS SEARCHED		
Minimum documentation searched (classification system followed by classification symbols) IPC 6 G06K		
Documentation searched other than minimum documentation to the extent that such documents are included in the fields searched		
Electronic data base consulted during the international search (name of data base and, where practical, search terms used)		
C. DOCUMENTS CONSIDERED TO BE RELEVANT		
Category °	Citation of document, with indication, where appropriate, of the relevant passages	Relevant to claim No.
X	US 5 578 817 A (ARREGUIT JAVIER ET AL) 26 November 1996 see column 2, line 40 - column 7, line 30 see column 11, line 47 - line 54 see column 12, line 62 - column 13, line 38 see column 22, line 35 - column 23, line 12 see column 26, line 43 - column 27, line 39	1-6,8, 10-12, 15,17, 19-21, 23,24
Y	--- -/--	7,13,14, 16,26-28
<input checked="" type="checkbox"/> Further documents are listed in the continuation of box C.		
<input checked="" type="checkbox"/> Patent family members are listed in annex.		
° Special categories of cited documents :		
"A" document defining the general state of the art which is not considered to be of particular relevance "E" earlier document but published on or after the international filing date "L" document which may throw doubts on priority claim(s) or which is cited to establish the publication date of another citation or other special reason (as specified) "O" document referring to an oral disclosure, use, exhibition or other means "P" document published prior to the international filing date but later than the priority date claimed	"T" later document published after the international filing date or priority date and not in conflict with the application but cited to understand the principle or theory underlying the invention "X" document of particular relevance; the claimed invention cannot be considered novel or cannot be considered to involve an inventive step when the document is taken alone "Y" document of particular relevance; the claimed invention cannot be considered to involve an inventive step when the document is combined with one or more other such documents, such combination being obvious to a person skilled in the art. "&" document member of the same patent family	
Date of the actual completion of the international search <p style="text-align: center;">10 May 1999</p>	Date of mailing of the international search report <p style="text-align: center;">18/05/1999</p>	
Name and mailing address of the ISA European Patent Office, P.B. 5818 Patentlaan 2 NL - 2280 HV Rijswijk Tel. (+31-70) 340-2040, Tx. 31 651 epo nl, Fax: (+31-70) 340-3016	Authorized officer <p style="text-align: center;">Bailas, A</p>	

INTERNATIONAL SEARCH REPORT

Inter. onal Application No
PCT/US 99/01706

C.(Continuation) DOCUMENTS CONSIDERED TO BE RELEVANT

Category °	Citation of document, with indication, where appropriate, of the relevant passages	Relevant to claim No.
X	GB 2 272 763 A (UNIV SHEFFIELD) 25 May 1994 see page 7, line 15 - page 11, line 11 ----	1-6,10, 11, 19-21, 23,24
Y	EP 0 572 009 A (SPACELABS MEDICAL INC) 1 December 1993 see column 1, line 30 - column 2, line 33 see column 14, line 48 - column 15, line 36 see abstract ----	13,14
Y	WO 97 06506 A (PHILIPS ELECTRONICS NV ;PHILIPS NORDEN AB (SE); PHILIPS ELECTRONIC) 20 February 1997 see page 3, line 5 - page 4, line 19 see abstract ----	16,26-28
Y	US 5 298 919 A (CHANG MINGTAI ET AL) 29 March 1994 see column 4, line 38 - line 59; figures 1,2 -----	7

INTERNATIONAL SEARCH REPORT

...information on patent family members

Inter. Patent Application No

PCT/US 99/01706

Patent document cited in search report	Publication date	Patent family member(s)	Publication date
US 5578817 A	26-11-1996	US 5703356 A	30-12-1997
		US 5288993 A	22-02-1994
		DE 19615568 A	14-11-1996
		US 5729009 A	17-03-1998
		US 5854482 A	29-12-1997
		AU 4881993 A	21-04-1994
		CA 2107743 A	06-04-1994
		DE 4333992 A	19-05-1994
		ES 2079288 A	01-01-1996
		FR 2696566 A	08-04-1994
		GB 2271847 A, B	27-04-1994
		IT 1262566 B	04-07-1996
		JP 6195168 A	15-07-1994
		NL 9301709 A	02-05-1994
GB 2272763 A	25-05-1994	WO 9411845 A	26-05-1994
		US 5793357 A	11-08-1998
EP 0572009 A	01-12-1993	US 5355149 A	11-10-1994
		CA 2096977 A	28-11-1993
WO 9706506 A	20-02-1997	EP 0786107 A	30-07-1997
US 5298919 A	29-03-1994	WO 9303475 A	18-02-1993