

(12) INTERNATIONAL APPLICATION PUBLISHED UNDER THE PATENT COOPERATION TREATY (PCT)

(19) World Intellectual Property  
Organization

International Bureau

(43) International Publication Date  
28 June 2018 (28.06.2018)



(10) International Publication Number  
**WO 2018/115298 A1**

(51) International Patent Classification:

*C21D 9/00* (2006.01)      *F27B 9/24* (2006.01)  
*C21D 9/46* (2006.01)      *B21D 22/02* (2006.01)  
*C21D 1/34* (2006.01)

TR), OAPI (BF, BJ, CF, CG, CI, CM, GA, GN, GQ, GW,  
KM, ML, MR, NE, SN, TD, TG).

**Declarations under Rule 4.17:**

— *as to applicant's entitlement to apply for and be granted a patent (Rule 4.17(ii))*

(21) International Application Number:

PCT/EP2017/084119

**Published:**

— *with international search report (Art. 21(3))*

(22) International Filing Date:

21 December 2017 (21.12.2017)

(25) Filing Language:

English

(26) Publication Language:

English

(30) Priority Data:

16382645.6      22 December 2016 (22.12.2016) EP

(71) Applicant: **AUTOTECH ENGINEERING A.I.E.**  
[ES/ES]; AIC-Automotive Intelligence Center, Parque Em-  
presarial Boroa P2-A4, 48340 AMOREBIETA-ETXANO  
(ES).

(72) Inventors: **LÓPEZ LAGE, Manuel**; Pol. Ind. Ca n'Estella,  
Passatge Edison, 4, 08635 SANT ESTEVE SESROVIRE  
(ES). **CASTILLA MORENO, Jordi**; Pol. Ind. Ca  
n'Estella, Passatge Edison, 4, 08635 SANT ESTEVE  
SESROVIRE (ES). **MERINO FERNÁNDEZ, Daniel**;  
Pol. Ind. Ca n'Estella, Passatge Edison, 4, 08635 SANT  
ESTEVE SESROVIRE (ES).

(74) Agent: **ZBM PATENTS - ZEA, BARLOCCI &  
MARKVARDSEN**; Pl. Catalunya, 1 2nd floor, 08002  
BARCELONA (ES).

(81) Designated States (*unless otherwise indicated, for every  
kind of national protection available*): AE, AG, AL, AM,  
AO, AT, AU, AZ, BA, BB, BG, BH, BN, BR, BW, BY, BZ,  
CA, CH, CL, CN, CO, CR, CU, CZ, DE, DJ, DK, DM, DO,  
DZ, EC, EE, EG, ES, FI, GB, GD, GE, GH, GM, GT, HN,  
HR, HU, ID, IL, IN, IR, IS, JO, JP, KE, KG, KH, KN, KP,  
KR, KW, KZ, LA, LC, LK, LR, LS, LU, LY, MA, MD, ME,  
MG, MK, MN, MW, MX, MY, MZ, NA, NG, NI, NO, NZ,  
OM, PA, PE, PG, PH, PL, PT, QA, RO, RS, RU, RW, SA,  
SC, SD, SE, SG, SK, SL, SM, ST, SV, SY, TH, TJ, TM, TN,  
TR, TT, TZ, UA, UG, US, UZ, VC, VN, ZA, ZM, ZW.

(84) Designated States (*unless otherwise indicated, for every  
kind of regional protection available*): ARIPO (BW, GH,  
GM, KE, LR, LS, MW, MZ, NA, RW, SD, SL, ST, SZ, TZ,  
UG, ZM, ZW), Eurasian (AM, AZ, BY, KG, KZ, RU, TJ,  
TM), European (AL, AT, BE, BG, CH, CY, CZ, DE, DK,  
EE, ES, FI, FR, GB, GR, HR, HU, IE, IS, IT, LT, LU, LV,  
MC, MK, MT, NL, NO, PL, PT, RO, RS, SE, SI, SK, SM,

(54) Title: METHOD FOR HEATING A BLANK AND HEATING SYSTEM

(57) Abstract: A method for manufacturing a steel component from a blank is provided. Firstly, a blank is placed in a conveyor system. Then, at least a preselected zone of the blank is preheated while the blank is retained at a predetermined preheating location. Finally, the blank is conveyed through a furnace. A preheating system for heating blanks in a production line is also provided.



WO 2018/115298 A1

## METHOD FOR HEATING A BLANK AND HEATING SYSTEM

This application claims the benefit of European Patent Application EP16382645.6 filed on December 22, 2016.

5

The present disclosure relates to heating systems, in particular to heating systems comprising a preheating system. The present disclosure further relates to methods for manufacturing steel components including hot forming of blanks.

10

## BACKGROUND

In the automotive industry, the development and implementation of lightweight materials or components is becoming more important in order to satisfy criteria for manufacturing lighter vehicles. The demand for weight reduction is especially driven by the goal of reduction of CO<sub>2</sub> emissions. Additionally, the growing concern regarding occupant safety also leads to the adoption of materials which improve the integrity and the energy absorption of the vehicle during a crash.

20

Hot stamping is a process which allows manufacturing hot formed structural components with specific properties which may include features such as a high strength, reduced thickness of components and lightness.

25

In a hot stamping production line system, a furnace system heats steel blanks at a predetermined temperature, e.g. above an austenization temperature, particularly above Ac<sub>3</sub> and softens the blanks to be hot formed. As the blanks exit the furnace, the blanks may be centered on a centering table to correctly place the heated blanks before being transferred to the press tool.

30

A conveyor system in such a production line is configured to convey blanks to and through a furnace. The furnace and the conveyor system are configured such that the blanks are heated to a desired temperature and for a desired time period (e.g. 3 – 10 minutes) before exiting the furnace. The transportation of the components through the furnace takes place on e.g. roller conveyors.

35

After centering, the blanks are transferred to a press system which deforms the blanks to the shape of the end product. After the press step, post operations such as trimming or drilling holes may be performed.

5 Typically in the automotive industry, High Strength Steel or Ultra High Strength Steel (UHSS) blanks are used for manufacturing components of a structural skeleton. The structural skeleton of a vehicle, e.g. a car, in this sense may include e.g. a bumper, pillars (A-pillar, B-pillar, C-pillar), side impact beams, a rocker panel, and shock absorbers.

10

UHSS can exhibit an optimized maximal strength per weight unit and advantageous formability properties. UHSS may have an ultimate tensile strength of at least 1000 MPa, preferably approximately 1500 MPa or up to 2000 MPa or more.

15

The steel blanks can obtain a suitable microstructure with high tensile strength by cooling the blanks in the press or after the press. Depending on the composition of the base steel material, blanks may need to be quenched, i.e. be cooled down rapidly from a high temperature to a low temperature, to 20 achieve a high tensile strength.

An example of steel used in the automotive industry is 22MnB5 steel. The composition of 22MnB5 is summarized below in weight percentages (rest is iron (Fe) and impurities):

25

C	Si	Mn	P	S
0.20–0.25	0.15–0.35	1.10–1.35	<0.025	<0.008
Cr	Ti	B	N	
0.15–0.30	0.02–0.05	0.002–0.004	<0.009	

30

Several 22MnB5 steels are commercially available having a similar chemical composition. However, the exact amount of each of the components of a 22MnB5 steel may vary slightly from one manufacturer to another. In other examples the 22MnB5 may contain approximately 0.23% C, 0.22% Si, and 0.16% Cr. The material may further comprise Mn, Al, Ti, B, N, Ni in different proportions.

Usibor<sup>®</sup> 1500P commercially available from Arcelor Mittal, is an example of UHSS which is supplied in ferritic-perlitic phase. It is a fine grain structure distributed in a homogenous pattern. The mechanical properties are related to this structure. After heating, a hot stamping process, and subsequent  
5 quenching, a martensite microstructure is created. As a result, maximal strength and yield strength increase noticeably.

The composition of Usibor<sup>®</sup> is summarized below in weight percentages (rest is iron (Fe) and impurities):

10

C	Si	Mn	P	S	Cr	Ti	B	N
0.24	0.27	1.14	0.015	0.001	0.17	0.036	0.003	0.004

Various other steel compositions of UHSS may also be used in the automotive industry. Particularly, the steel compositions described in EP 2 735 620 A1 may be considered suitable. Specific reference may be had to table 1 and  
15 paragraphs 0016 – 0021 of EP 2 735 620, and to the considerations of paragraphs 0067 – 0079. In some examples the UHSS may contain approximately 0.22% C, 1.2% Si, and 2.2% Mn. These steels may be air hardened, i.e. they do not require quenching in e.g. a press tool in order to obtain a martensitic microstructure.

20

Steels of any of these compositions (22MnB5 steels in general, and Usibor<sup>®</sup> in particular) may be supplied with a coating in order to prevent corrosion and oxidation damage. This coating may be e.g. an aluminum-silicon (AlSi) coating or a coating mainly comprising zinc or a zinc alloy.

25

The increase in a component strength obtained by these processes and materials may allow for a thinner gauge material to be used, which results in weight savings over conventionally cold stamped mild steel components for automotive applications.

30

Simulations performed during the design phase of a typical vehicle component can identify points or zones of the formed component that need reinforcement (because lighter and thinner metal sheets and blanks are used) in order to increase strength and/or stiffness. Alternatively a redesign may be done in  
35 order to steer deformations.

In that sense, there are several procedures with which some zones of a component can be reinforced or softened in order to redistribute stress and save weight by reducing the thickness of the component. These known  
5 procedures for reinforcing a component are, for example, procedures adding welded reinforcements prior to any deforming process. Such reinforcements may be “patchworks” in which partial or complete overlapping of several blanks may be used, blanks or plates of different thickness that may be welded “edge to edge”, i.e. Tailor Welded Blanks (TWB). Alternatively, blanks  
10 may comprise different thicknesses with a continuous thickness transition produced by a controlled adjustment of roll gaps on a cold rolling mill, i.e. Tailor Rolled Blanks (TRB). Structural mechanical requirements can thus be achieved theoretically with a minimum of material and thickness (weight).

15 A blank with different thicknesses may not be homogeneously heated in the furnace, i.e. inner parts of the thick regions may not be sufficiently heated, and thus, the temperature in the whole blank may not be the same. In some examples, the blank may comprise different materials i.e. different properties. Such blanks may be formed e.g. by joining at least two blanks made of  
20 different material (which might also have different thicknesses). The resulting blank would therefore comprise the properties of the joined materials.

If the entire blank is not homogeneously heated in the furnace to a predetermined temperature e.g. an austenization temperature or higher, the  
25 result of a further hot deforming process may not be satisfactory i.e. some parts of the blank may not be malleable enough to be correctly deformed and so the blank may be broken during deformation process. Furthermore, due to the insufficient temperature gradient, the ferritic-perlitic initial phase may not be completely transformed into austenite along the whole thickness of the  
30 blank, and consequently, in a subsequent quenching step, the desired microstructure e.g. martensite might not be created in those zones which had not been sufficiently heated. Furthermore, overheating the blanks may also lead to undesired changes of the material properties and/or may affect the coating.

35 A blank comprising thick regions may be left in the furnace for longer periods of time to ensure that such thick regions are adequately heated. The time the

blank remains in the furnace may be modified e.g. by decreasing the speed of the conveyor system or by increasing the furnace length. Depending on the process, some furnace or furnace systems may be 25 meters long, or more, and moreover, as the length of the furnace grows, the occupied space  
5 increases accordingly. However, with such alternatives, the overall processing time may be substantially increased.

In conclusion, there is a need for methods and tools for processing blanks which at least partially solve some of the aforementioned problems.

10

## SUMMARY

In a first aspect, a method for manufacturing a steel component from a blank is provided. Firstly, a blank is placed in a conveyor system. Then, at least a  
15 preselected zone of the blank is preheated while the blank is retained at a predetermined preheating location. Finally, the blank is conveyed through a furnace.

As a consequence of preheating, the time the blank remains in the furnace  
20 may be decreased, and thus, the length of the furnace may be reduced. A furnace length reduction involves costs reduction e.g. less energy consumption, and also reduces the space taken up by the furnace system. Furthermore, portions of a conveyor system may become dirty, i.e. they may become contaminated by the hot AlSi coating. By using preheating, the length  
25 of the contaminated portions may be reduced, and therefore, the costs related to the replacement of the parts which form the dirty portion may also decrease.

In some examples, the blank may be retained at a predetermined preheating  
30 location by stopping elements.

In some examples, the stopping elements may be retractable pins configured to be displaceable in an up-and-down motion for retaining the blank in the preheating location.

35

In some examples, the stopping elements may be elevating bars configured to lift the blank perpendicular to a conveying direction.

In some examples, the blank may be retained at the predetermined preheating location by stopping the conveyor system for a predetermined period of time.

- 5 In some examples, the preheating step may comprise preheating at least the thickest zone of the blank.

In some examples, the preheating step may comprise preheating the whole blank.

10

In some examples, the preheating step may comprise preheating the whole blank to a first temperature and preheating at least the thickest zone of the blank to a second temperature, wherein the second temperature is higher than the first temperature.

15

In some examples, the preheating step comprises heating at least a preselected zone of the blank below an Ac3 temperature, specifically between 300 – 820 °C, more specifically between 500 – 700 °C.

20

In some examples, the preheating step may be done in 25 seconds or less, preferably in 10 seconds or less.

In some examples, the method may further comprise transferring the heated blank to a press tool, hot deforming the blank and quenching the blank.

25

In a second aspect, a heating system for heating blanks in a production line is provided. The heating system comprises a furnace and a conveyor system for conveying the blanks through the furnace which is configured to temporarily retain the blank in a predetermined preheating location upstream from the furnace. The system also comprises a preheating system for preheating at least a preselected zone of a blank preheating location.

30

As the preheating system is placed just before the furnace i.e. not in a separate preheating system, the temperature of the preheated zones is not decreased as a consequence of being transferred from the preheating system to the furnace, which involves a homogeneous heating when exiting the furnace. Additionally, no extra time is added to the process as the preheating

35

process uses the time that the blank remains in the conveyor system to preheat the preselected zones. The heating process can thus be improved, or optimized.

- 5 In some examples the heating system may comprise stopping elements to retain the blank at the predetermined location, wherein said stopping elements are retractable pins configured to be displaceable in an up-and-down motion or elevating bars configured to lift the blank perpendicularly to a conveying direction.

10

In some examples, the preheating system may comprise a base, at least one heating element and a support structure. In some examples, the heating elements may be infrared, induction, flame, fluid or electric heaters.

## 15 BRIEF DESCRIPTION OF THE DRAWINGS

Non-limiting examples of the present disclosure will be described in the following, with reference to the appended drawings, in which:

- 20 Figure 1 schematically illustrates a side view of a production line according to an example;

Figures 2a – 2d schematically illustrate different examples for retaining a blank in a predetermined preheating location;

25

Figures 3a – 3c schematically illustrate various blanks heated according to different examples;

- 30 Figure 4a and 4b schematically illustrate examples of a preheating system; and

Figure 5 schematically illustrates an example of a method for manufacturing a blank.

## 35 DETAILED DESCRIPTION

Figure 1 shows a blank 1 in a production line 100. The production line 100

may be e.g. a hot deformation or hot stamping production line which may comprise a conveyor system 120 to transport the blank 1 through the production line 100. The conveyor system 120 may comprise e.g. a plurality of conveyor rollers, parallel conveyor belts or walking beams. The conveyor system 120 in such a case may be driven using e.g. motors. In this case, the speed of the conveyor system 120 may be controlled by controlling the speed of the motors.

According to an example, the conveyor system 120 may comprise a feeding system and a furnace conveyor system to transport the blank through the furnace.

The blank 1 may be placed in the conveyor system 120 by e.g. an industrial transfer robot (not shown) e.g. after being cut from a steel coil, and may be conveyed to a preheating system 110.

The preheating system 110 may comprise a plurality of heating elements 111 arranged in a base 112 to preheat the blank 1 before entering the furnace. The base 112 of the preheating system 110 may be of any suitable size and shape, which may be determined e.g. by the dimensions of the blank. Accordingly, the number, size and shape of heating elements 111 may vary depending on e.g. the blank size or the desired blank configuration. A further support structure 113 may be used to fix the base 112 of the preheating system 110 to the floor. In other examples the support structure may be e.g. be coupled to the conveyor system, suspended from the ceiling or anchored to a wall.

The blank 1 may then be conveyed into the furnace 130 where it may be heated to a predetermined temperature, e.g. above an austenization temperature, so as to prepare the blank 1 for subsequent processes. In particular, the blank may be heated to Ac3 or above.

Depending on the blank material and the coating, the furnace temperature and the time that the blank remains in the furnace can vary. When the blank has been subjected to a preheating process as described before, the time in the furnace may be reduced compared to the time in the furnace of those blanks without a preheating process.

The heated blank 1 may exit the furnace 130 through a door (not shown) configured to open when the blank 1 arrives, and to close again when the blank 1 has left the furnace 130. The blank 1 may be transported by a conveyor system 120, e.g. a conveyor belt or a roller conveyor, to a centering system 140, e.g. a centering table, to be correctly positioned for subsequent processing.

A centering table 140 may comprise a plurality of centering pins 141 which can be passive or can be actively moved to correctly position and center the blank 1.

After being centered and correctly positioned, the blank 1 may be transferred to a press tool 150 for deforming and quenching. The blank 1 may be transferred to the press tool 150 by a transferring system (not shown), e.g. an industrial transfer robot, which may pick up the blank 1 from the conveyor system 120 and may place it on the pressing tool 150. The transfer robot may comprise a plurality of gripping units to grab and pick up the blank 1 from the conveyor means 120.

The pressing tool 150 may be provided with cooling means (not shown) e.g. water supplies or any other suitable means, to quench the blank 1 simultaneously to the hot deforming process. The cooling or quenching may be done homogeneously for the whole blank 1. Typically, channels may be provided in the dies of the press tool through which cold water or other liquid may be conducted. This cools the contact surfaces of the press tool so that the blank is quenched.

Figures 2a – 2d show the blank 1 in a predetermined preheating location, e.g. under the preheating system, in which the blank 1 may be subjected to a preheating process. The blank 1 may be retained in the predetermined preheating location e.g. where the preheating system overlaps substantially the whole blank or at least the preselected zone to be preheated, during the entire preheating process. The blank 1 may be preheated about 15 seconds or less at a temperature between 600 – 700 °C. During the preheating process the blank 1 may still in the predetermined preheating location.

In the example shown in Figure 2a, the blank 1 is retained in a predetermined preheating location by stopping the conveyor system 120 e.g. a conveyor belt. According to this example, the blank 1 would firstly be conveyed to the predetermined preheating location. Secondly, the blank would be retained in that position, i.e. predetermined preheating location, by stopping the conveyor system e.g. stopping the motion of the conveyor belt(s). The blank would then be preheated, and finally, once the preheating process has finished, the blank would be conveyed to the furnace.

10 A conveyor system comprising conveyor rollers or walking beams may alternatively be used. In these examples, the conveyor system is stopped by avoiding the upward and forward movement of the walking beams or the rotation of the conveyor rollers.

15 The conveyor system 120 may be programmed to stop its movement when the blank is detected in the appropriate position e.g. by using sensors. In other examples the conveyor system may be programmed to stop periodically e.g. every 15 – 30 seconds.

20 Figures 2b and 2c show a lateral view and a top view respectively of a conveyor system 120, e.g. conveyor rollers or walking beams, which may comprise at least a stopping element configured to retain the blank in the predetermined preheating location. Such stopping elements may be retractable pins 122.

25 The retractable pins 122 may be configured to be up-and-down displaceable for retaining the blank 1 in a predetermined preheating location i.e. avoiding its forward movement in the conveying direction (indicated by the x axis). A difference between this example and the example of Figure 2a is that the conveyor system 120 of Figures 2b and 2c may be operating at a substantially constant speed. As only the blank that is preheated is stopped, there is no need to interrupt the operation of the other blanks.

35 The retractable pins 122 may be retracted e.g. under the conveyor system 120, until the blank 1 is detected e.g. by sensors. The retractable pins 122 may be configured to move up to retain the blank 1 when the blank 1 is detected in an adequate location, i.e. a predetermined preheating location.

The retractable pins 122 may be in the “up” position, i.e. totally protruding, before and during the preheating process. In the same way, the retractable pins 122 may be configured to retract after the preheating process has finished, and so, the blank 1 may be conveyed to the furnace.

5

Figure 2d shows another example to retain the blank 1 in a predetermined preheating location. In the example of Figure 2d, the stopping elements or stops may be elevating bars 123 configured to displace the blank 1 perpendicularly to a conveying direction  $x$ . The elevating bars 123 may be located interleaved with the conveyor system 120 e.g. a plurality of conveyor belts or conveyor rollers, so as to avoid blocking the movement of the conveyor system 120.

10

The elevating bars 123 may be configured to be perpendicularly displaceable (indicated by the  $y$  axis) to the conveying direction when the blank 1 is detected, e.g. by sensors, in a predetermined preheating location. According to this example, the elevating bars 123 may be “hidden”, i.e. retracted, until the blank 1 is in a predetermined preheating location. At that time, the elevating bars 123 would project outwardly and the blank 1 would therefore be perpendicularly displaced from the conveyor system 120 i.e. it would be elevated above the conveyor system (while the conveyor continues operating). The blank 1 may then be subjected to a preheating process. After the preheating process, the elevating bars 123 may be retracted and thus, the blank 1 may be placed onto the conveyor system 120 to be conveyed to the furnace.

20

25

Figure 3a depicts a rectangular blank 300 which has been preheated at  $T_1$  temperature, e.g. 630°C. When heating a blank (with or without zones of different thickness), it may be desirable to increase the efficiency of the heating process e.g. reducing the heating time. By preheating the blanks (or at least certain zones of the blank) the heating process may be optimized as the blanks may stay less time in the furnace. Moreover, as the time in the furnace may be reduced, the furnace length may be decreased which, at least, reduces the energy consumption and the space taken up by the furnace.

30

35

Figure 3b shows a rectangular blank, the central zone 310 of which has been preheated to  $T_1$  temperature. The preheated zone 310 may correspond to e.g.

the thickest zone of the blank. By preheating the thick zone of a blank, a homogeneous heating e.g. above  $A_{c3}$ , of the whole blank may be assured in a subsequent heating process.

5 Additionally, in a blank with zones of different thickness and/or different materials, e.g. a TWB, each zone may be preheated at a different temperature. Figure 3c illustrates a rectangular blank with three zones of different thicknesses, and wherein the temperature at which each zone has been preheated is different. A first zone 320 may be preheated at  $T_1$ , a  
10 second zone 330 which may correspond to the thickest zone of the blank, may be heated at  $T_2$  e.g. between 600 – 700 °C and finally, a third zone 340, which may correspond to the thinner zone of the blank, may not be heated. Temperature  $T_2$  corresponding to the second zone, i.e. the thickest zone of the blank is therefore higher than the  $T_1$  corresponding to the first zone.

15

In other examples, the whole blank may be preheated at  $T_1$  while a predetermined zone, e.g. the thickest zone of the blank, may be preheated at  $T_2$ , wherein  $T_2$  is higher than  $T_1$ .

20 In some examples, the blank may be made of different materials (e.g. different types of steels) which may e.g. have different thermal conductivities. Each material may therefore need to be heated for a specific heating time to reach a predetermined temperature. In such cases the different material areas may be heated at different temperatures.

25

Figures 4a depicts a preheating system 110 comprising a rectangular base 112 and heating elements 111a arranged on it. In the depicted example, all the heating elements 111a are switched on, and therefore the whole blank would be preheated (see Figure 3a).

30

In other examples, the blank may be selectively preheated. Figure 4b shows an example of a preheating system 110 wherein the heating elements 111a, 111b may be configured to selectively turn on and off for locally preheating only preselected zones of the blank, and thereby a heating pattern is created.

35

In the example of Figure 4b only a central zone of the blank would be preheated (see Figure 3b).

The pattern may be formed by arranging the heating elements 111a, 111b in a predetermined manner (not shown) or it may be created by selectively switching off certain heating elements 111b while leaving other heating elements 111a switched on as shown in Figure 4b. The switched on heating elements 111a preheat preselected zones of the blank at a desired temperature, for example at a temperature between 600 – 700 °C.

In further examples, the amount of heat delivered by the heating elements 111a that are switched on may be regulated, e.g. controlling the power of the heating elements, so that different temperatures may be achieved.

By switching the heating elements on or off and/or by controlling the output power of the heating elements a tailored heating pattern taking into account e.g. the dimensions of the blank and/or the position of the preselected zone of the blank to be preheated, can be provided.

In some examples, the heating elements 111a, 111b may be infrared heaters, particularly infrared heating lamps. In other examples, induction heaters, flame or hot air directed to the blank may be used. In other examples, the blank may be heated by contacting a heating plate which is heated by electric heaters embedded in the heating plate or by a hot fluid, e.g. water, oil, etc., flowing through channels.

Figure 5 shows a method to manufacture a steel component from a blank with zones of different thickness according to an example. Firstly, a blank may be placed 510 in a conveyor system e.g. by an industrial transfer robot. Optionally, if the blank has not been positioned in a predetermined preheating location the blank may be then conveyed 520 to a suitable preheating location, i.e. in a proper position with respect to a preheating system. Once in the predetermined preheating location, the blank may be retained 530 in such position e.g. by stopping the conveyor system or by stops or stopping elements as described before. The blank, or at least a preselected zone of the blank and in particular a zone of the blank that has increased thickness, may then be preheated 540 e.g. at a temperature of about 600 – 700 °C during less than 15 seconds.

When the preheating process is ended, the blank may be conveyed through

the furnace 550 to be heated e.g. at a temperature above Ac3. The blank may be in the furnace for about 3 minutes. After the heating process, the heated blank may exit the furnace and may be centered and correctly positioned in a centering system e.g. centering table, arranged downstream. The blank may then be transferred to a press tool e.g. by an industrial transfer robot, where it may be hot deformed to obtain (almost) the final shape. The blank may also be entirely or partially quenched in the press tool e.g. by supplying cold water. Optionally the blank may further be subjected to post processing steps such as e.g. cutting, trimming, and/or joining to further components using e.g. welding.

Although only a number of examples have been disclosed herein, other alternatives, modifications, uses and/or equivalents thereof are possible. Furthermore, all possible combinations of the described examples are also covered. Thus, the scope of the present disclosure should not be limited by particular examples, but should be determined only by a fair reading of the claims that follow.

## CLAIMS

1. A method for manufacturing a steel component from a blank, the method comprising:
- 5        placing a blank in a conveyor system;  
         preheating at least a preselected zone of the blank; and  
         conveying the blank through a furnace, and wherein the preheating comprises retaining the blank at a predetermined preheating location.
- 10    2. The method according to claim 1, wherein the blank is retained at the predetermined preheating location by stopping elements.
3. The method according to claim 2, wherein the stopping elements are retractable pins configured to be displaceable in an up-and-down motion for  
15    retaining the blank in the preheating location.
4. The method according to claim 2, wherein the stopping elements are elevating bars configured to lift the blank perpendicularly to a conveying  
20    direction.
5. The method according to claim 1, wherein the blank is retained at the predetermined preheating location by stopping the conveyor system for a predetermined period of time.
- 25    6. The method according to any of claims 1 – 5, wherein the preheating step comprises preheating at least the thickest zone of the blank.
7. The method according to any of claims 1 – 6, wherein the preheating step comprises preheating the whole blank.  
30
8. The method according to claim 7, the preheating step comprising:  
         preheating the whole blank to a first temperature; and  
         preheating at least the thickest zone of the blank to a second  
35    temperature, wherein the second temperature is higher than the first temperature.

9. The method according to any of claims 1 – 8 wherein the preheating step comprises heating at least a preselected zone of the blank below an Ac3 temperature, specifically between 300 – 820 °C, more specifically between 500 – 700 °C .
- 5
10. The method according to any of claims 1 – 9, wherein the preheating is done in 25 seconds or less, preferably in 10 seconds or less.
11. The method according to any of claims 1 – 10 further comprising:
- 10       transferring the heated blank to a press tool;  
          hot deforming the blank; and  
          quenching the blank.
12. A heating system for heating blanks in a production line, the heating system comprising:
- 15       a furnace;  
          a conveyor system for conveying the blanks through the furnace; and  
          a preheating system for preheating at least a preselected zone of a blank, wherein the conveyor system is configured to temporarily retain
- 20       the blank in a predetermined preheating location upstream from the furnace.
13. The heating system according to claim 12, wherein the heating system comprises stopping elements to retain the blank at the predetermined location, wherein preferably the stopping elements are as defined in claim 3 or 4.
- 25
14. The heating system according to any of claims 12 – 13, wherein the preheating system comprises:
- 30       a base;  
          at least one heating element; and  
          a support structure.
15. The heating system according to claim 14, wherein heating elements are infrared, induction, flame, fluid or electric heaters.

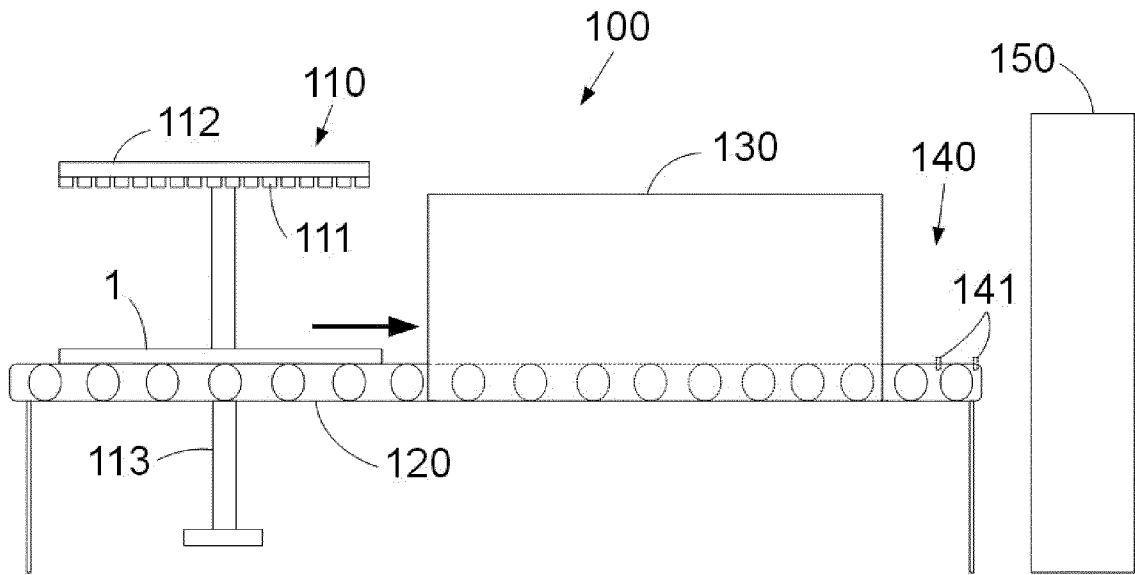

FIG. 1

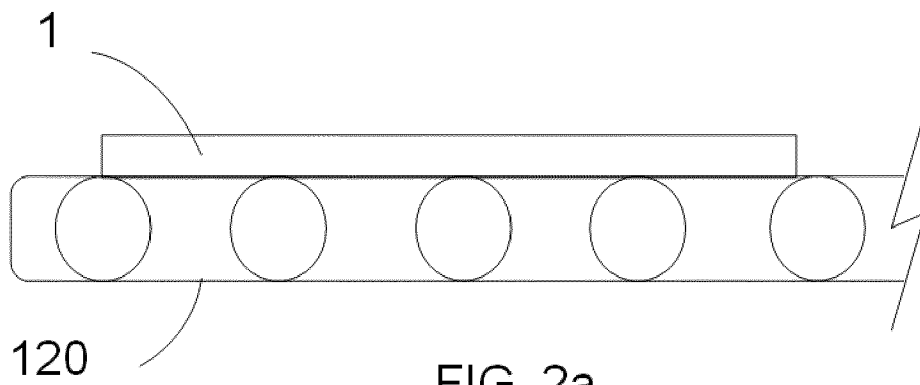

FIG. 2a

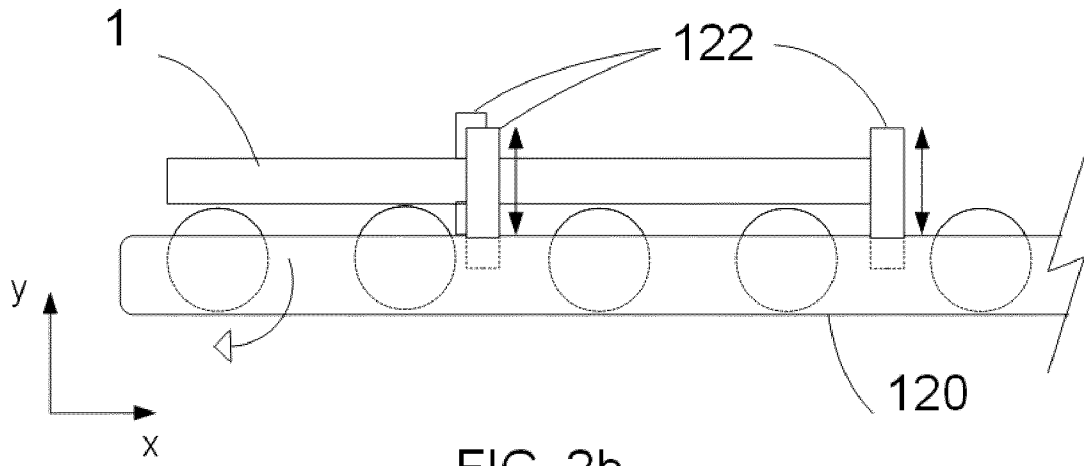

FIG. 2b

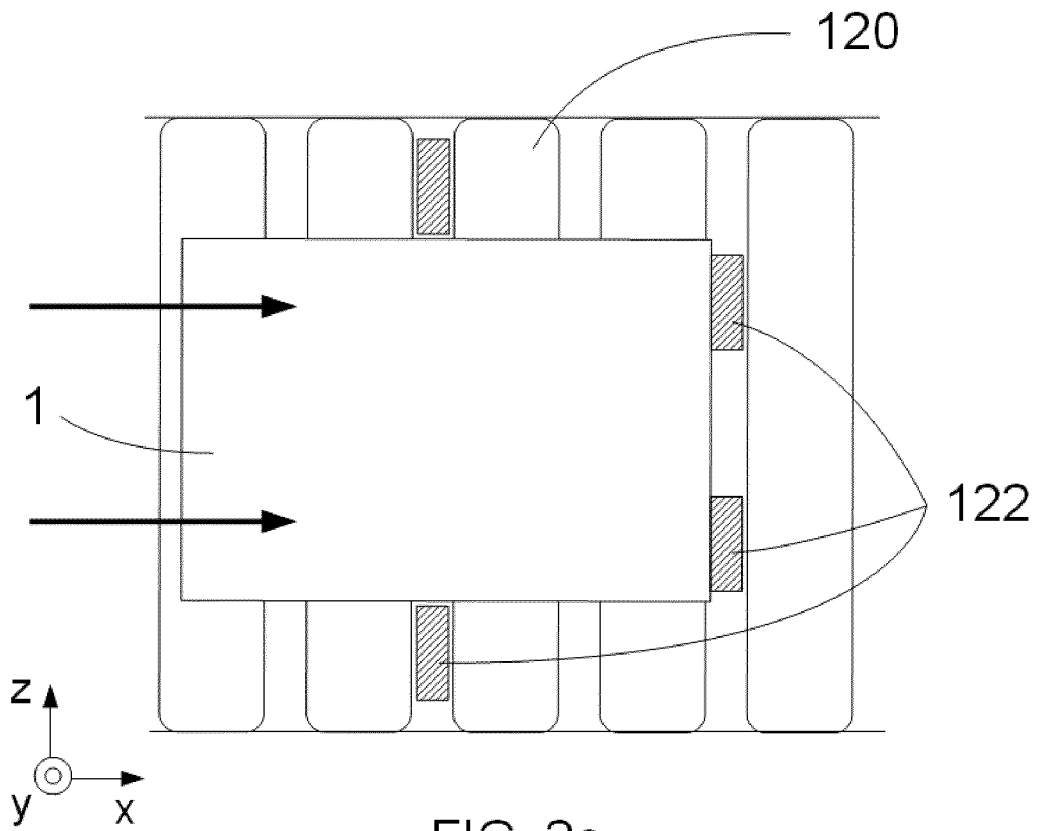

FIG. 2c

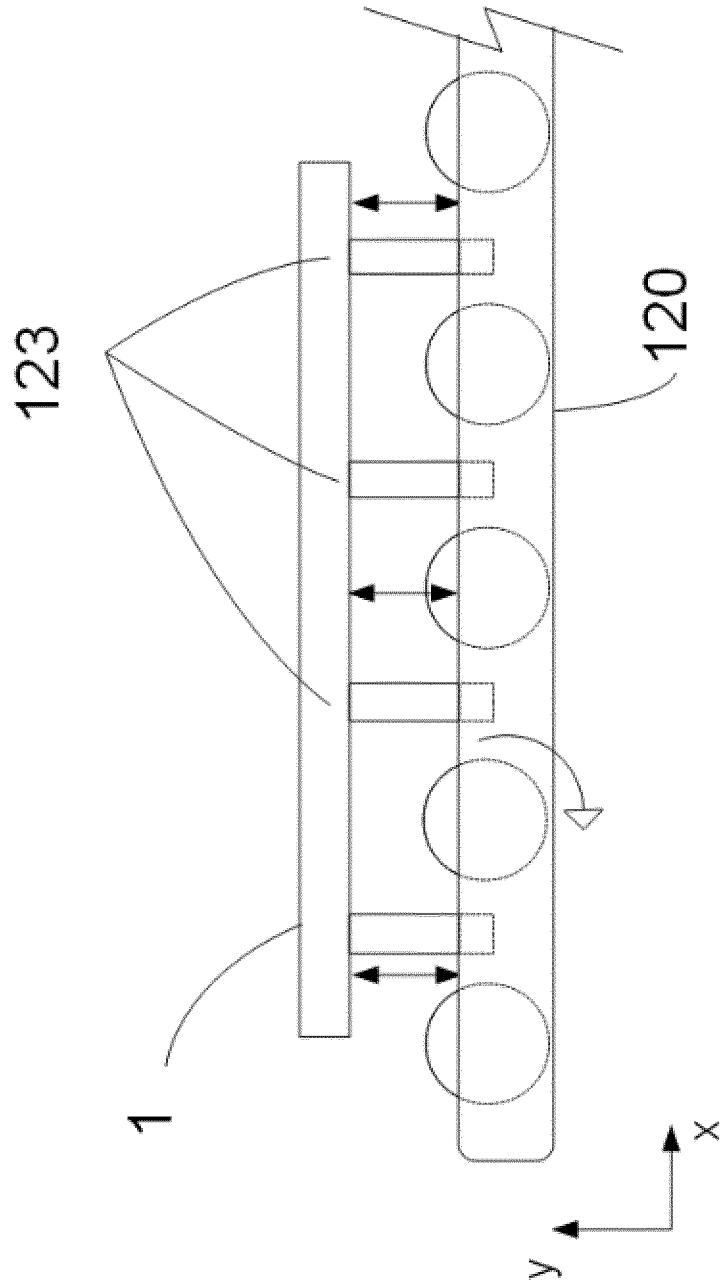

FIG. 2d

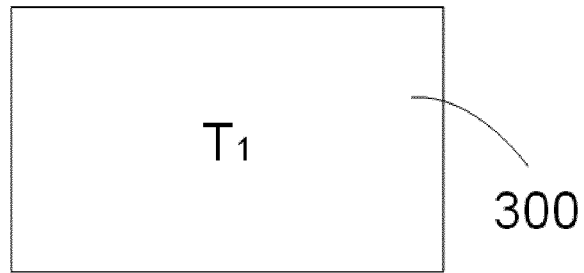

FIG. 3a

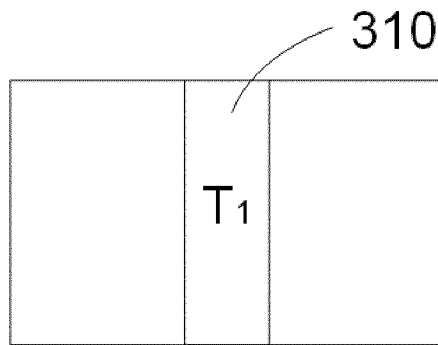

FIG. 3b

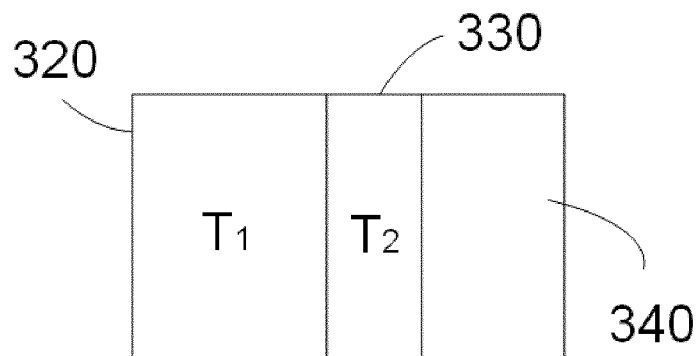

FIG. 3c

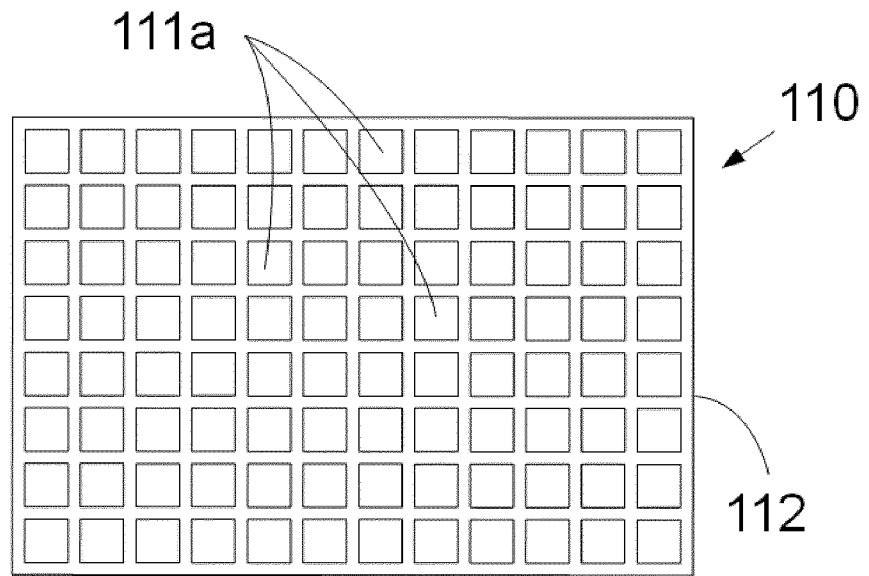

FIG. 4a

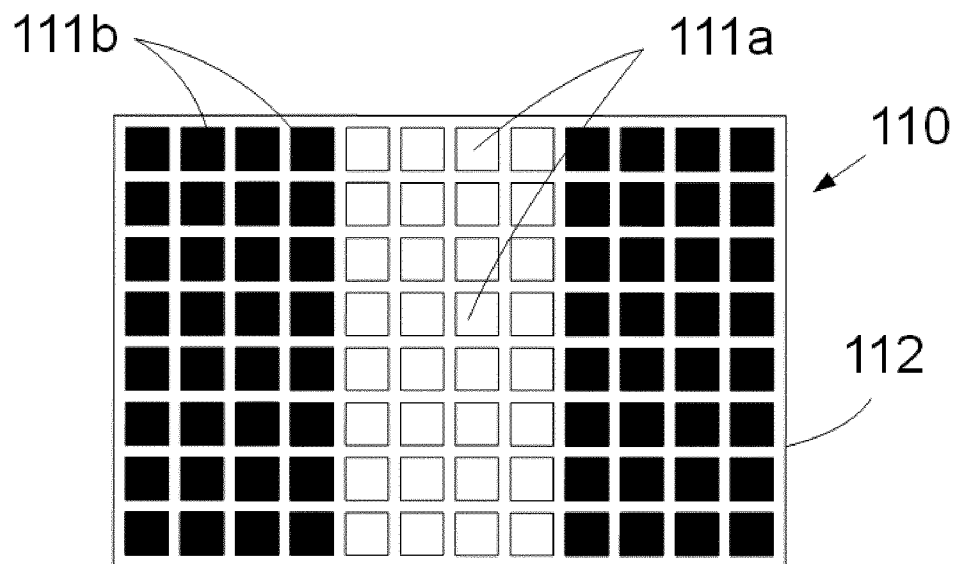

FIG. 4b

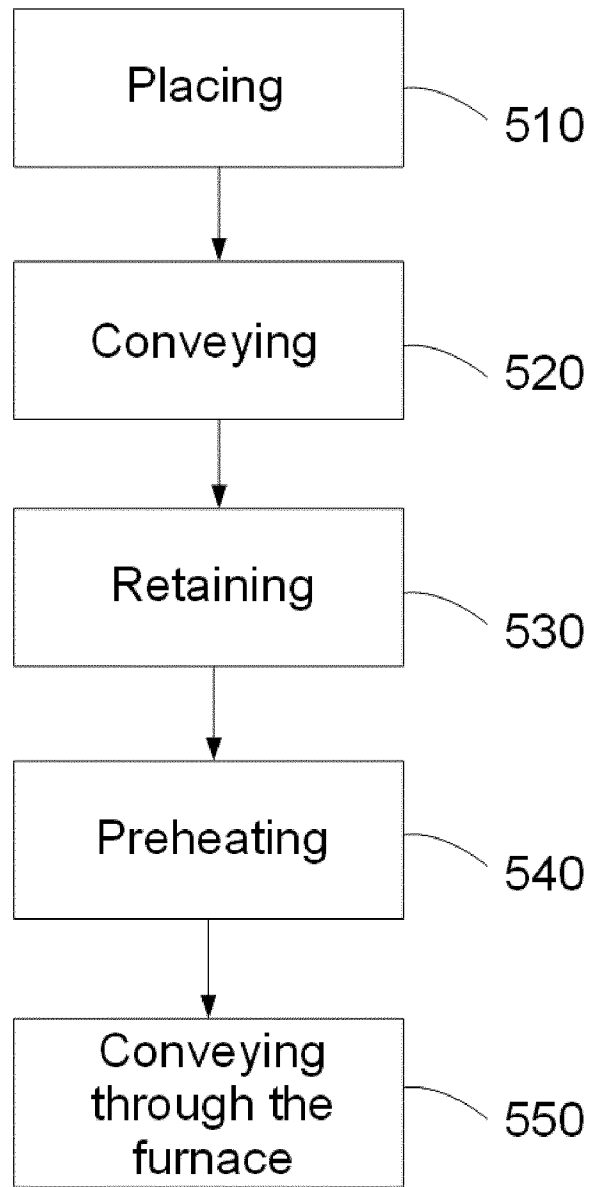

Fig. 5

**INTERNATIONAL SEARCH REPORT**

International application No  
PCT/EP2017/084119

A. CLASSIFICATION OF SUBJECT MATTER  
INV. C21D9/00 C21D9/46 C21D1/34 F27B9/24 B21D22/02  
ADD.  
According to International Patent Classification (IPC) or to both national classification and IPC

B. FIELDS SEARCHED  
Minimum documentation searched (classification system followed by classification symbols)  
C21D F27B B21D

Documentation searched other than minimum documentation to the extent that such documents are included in the fields searched

Electronic data base consulted during the international search (name of data base and, where practicable, search terms used)  
EPO-Internal, WPI Data

C. DOCUMENTS CONSIDERED TO BE RELEVANT

Category*	Citation of document, with indication, where appropriate, of the relevant passages	Relevant to claim No.
X	EP 2 233 593 A2 (THYSSENKRUPP UMFORMTECHNIK GMB [DE]; THYSSENKRUPP SOFEDIT S A S [FR]) 29 September 2010 (2010-09-29) columns 25-31; figures 1-6 -----	1-7,9-15
X	EP 2 615 396 A1 (LINDE AG [DE]) 17 July 2013 (2013-07-17) paragraphs [0024], [0039] - [0041], [0044]; figure 1 -----	1-7,9-15
X	DE 10 2014 110415 A1 (VOESTALPINE STAHL GMBH [AT]) 28 January 2016 (2016-01-28) paragraphs [0044], [0051] - [0062]; claim 1; figure 1 -----	1-15

Further documents are listed in the continuation of Box C.

See patent family annex.

\* Special categories of cited documents :

- "A" document defining the general state of the art which is not considered to be of particular relevance
- "E" earlier application or patent but published on or after the international filing date
- "L" document which may throw doubts on priority claim(s) or which is cited to establish the publication date of another citation or other special reason (as specified)
- "O" document referring to an oral disclosure, use, exhibition or other means
- "P" document published prior to the international filing date but later than the priority date claimed

- "T" later document published after the international filing date or priority date and not in conflict with the application but cited to understand the principle or theory underlying the invention
- "X" document of particular relevance; the claimed invention cannot be considered novel or cannot be considered to involve an inventive step when the document is taken alone
- "Y" document of particular relevance; the claimed invention cannot be considered to involve an inventive step when the document is combined with one or more other such documents, such combination being obvious to a person skilled in the art
- "&" document member of the same patent family

Date of the actual completion of the international search

19 February 2018

Date of mailing of the international search report

28/02/2018

Name and mailing address of the ISA/

European Patent Office, P.B. 5818 Patentlaan 2  
NL - 2280 HV Rijswijk  
Tel. (+31-70) 340-2040,  
Fax: (+31-70) 340-3016

Authorized officer

Rischard, Marc

# INTERNATIONAL SEARCH REPORT

Information on patent family members

International application No PCT/EP2017/084119
---

Patent document cited in search report	Publication date	Patent family member(s)	Publication date	
EP 2233593	A2	29-09-2010	DE 102009014670 A1 EP 2233593 A2	30-09-2010 29-09-2010
-----				
EP 2615396	A1	17-07-2013	NONE	
-----				
DE 102014110415	A1	28-01-2016	CA 2955279 A1 CN 106715725 A DE 102014110415 A1 EP 3172345 A1 US 2017218473 A1 WO 2016012442 A1	28-01-2016 24-05-2017 28-01-2016 31-05-2017 03-08-2017 28-01-2016
-----				