



INTERNATIONAL APPLICATION PUBLISHED UNDER THE PATENT COOPERATION TREATY (PCT)

<p>(51) International Patent Classification <sup>5</sup> :  H01G</p>	<p>A2</p>	<p>(11) International Publication Number: <b>WO 92/12525</b>  (43) International Publication Date: 23 July 1992 (23.07.92)</p>
------------------------------------------------------------------------------	-----------	----------------------------------------------------------------------------------------------------------------------------------------

(21) International Application Number: PCT/US91/09583  
 (22) International Filing Date: 18 December 1991 (18.12.91)  
 (30) Priority data:  
 636,797 2 January 1991 (02.01.91) US  
 (71) Applicant: ZENITH ELECTRONICS CORPORATION  
 [US/US]; Zenith Center, 1000 Milwaukee Avenue, Glen-  
 view, IL 60025 (US).  
 (72) Inventors: PEARLMAN, Jerry, K. ; 21 Linden, Wilmette,  
 IL 60091 (US). LERNER, Martin, L. ; 202 Gail Ave.,  
 River Forest, IL 60305 (US).  
 (74) Agent: CHRYSTAL, John, J.; Ladas & Parry, 224 S. Mi-  
 chigan Ave., Chicago, IL 60604 (US).

(81) Designated States: AT (European patent), BE (European patent), CH (European patent), DE (European patent), DK (European patent), ES (European patent), FR (European patent), GB (European patent), GR (European patent), IT (European patent), JP, KR, LU (European patent), MC (European patent), NL (European patent), SE (European patent).

**Published**  
*Without international search report and to be republished upon receipt of that report.*

(54) Title: TENSION MASK COLOR CRT WITH A CURVED FACEPLATE

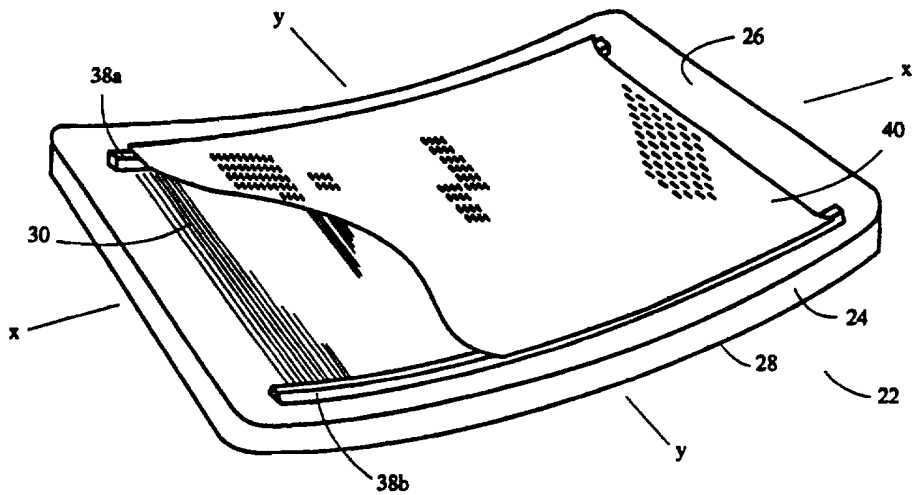

(57) Abstract

A color cathode ray tube has a faceplate with curved inner surface and a curved outer surface. A tensed shadow mask is located adjacent to the inner surface and secured to discrete mask support rails affixed to said inner surface. The said rails have a curvature related to the curvature of the faceplate inner surface.

**FOR THE PURPOSES OF INFORMATION ONLY**

Codes used to identify States party to the PCT on the front pages of pamphlets publishing international applications under the PCT.

AT	Austria	ES	Spain	MG	Madagascar
AU	Australia	FI	Finland	ML	Mali
BB	Barbados	FR	France	MN	Mongolia
BE	Belgium	GA	Gabon	MR	Mauritania
BF	Burkina Faso	GB	United Kingdom	MW	Malawi
BG	Bulgaria	GN	Guinea	NL	Netherlands
BJ	Benin	GR	Greece	NO	Norway
BR	Brazil	HU	Hungary	PL	Poland
CA	Canada	IT	Italy	RO	Romania
CF	Central African Republic	JP	Japan	RU	Russian Federation
CG	Congo	KP	Democratic People's Republic of Korea	SD	Sudan
CH	Switzerland	KR	Republic of Korea	SE	Sweden
CI	Côte d'Ivoire	LI	Liechtenstein	SN	Senegal
CM	Cameroon	LK	Sri Lanka	SU	Soviet Union
CS	Czechoslovakia	LU	Luxembourg	TD	Chad
DE	Germany	MC	Monaco	TG	Togo
DK	Denmark			US	United States of America

TENSION MASK COLOR CRT WITH A CURVED  
FACEPLATE

This invention relates to color cathode ray picture tubes, and is addressed to tubes having tension masks in conjunction with a curved faceplate. The invention is applicable to the manufacture of color tubes of various types, including those used in home entertainment type television receivers of both standard resolution and high definition, and in medium-resolution and high-resolution tubes used in color monitors.

The shadow mask is a part of the cathode ray tube front assembly, and is located in close adjacency to the phosphor screen deposited on the inner surface of the faceplate. As used herein, the term "shadow mask" means an apertured metal component that acts as a color-selection electrode, or "parallax barrier," which ensures that each of the three beams generated by the electron gun located in the neck of the tube lands only on assigned phosphor targets. In the shadow mask embodiments described herein, the mask is supported in predetermined distances from the inner surface of the face panel by structures known as "rails." The predetermined distance is termed the "Q-height" or "Q-distance."

Prior art color cathode ray tubes having tensed foil shadow masks have faceplates which are flat to match the flatness of an associated foil mask. An exemplary tube of this type is fully described in our U.S. Patent No. 4,891,546.

For the purposes of this disclosure, shadow mask types are categorized as (a) "slot" masks which are characterized by having the strips comprising the mask coupled by closely spaced ties which form the slots, (b) "slit" masks, in which the strips comprising the mask are not interconnected by ties, and which run untied the whole length of the mask; and (c), "tied slit" masks in which the strips are loosely coupled by widely spaced ties.

An example of a widely used slot mask is one in which the slots are bridged by tie bars at frequent intervals. Typically, the spacing between the two tie bars in a given slot is of the same order as the center-to-center spacing between the two metal strips which form the slot. Due to the high density of tie bars, such a mask has very substantial mechanical strength in the transverse direction; i.e. at right angles to the major axis of the slots. The aperture structure of a mask of this type is depicted in figure 7.

In the tied-slit mask, the wide tie spacing is such as to produce a strip coupling which promotes handleability of the mask during mask and tube fabrication. The wide strip coupling facilitates damping of strip vibration when mounted in the tube, but is insufficient to induce unacceptable Poisson contraction of the mask when it is uniaxially tensed along the direction of the strips in the plane of the mask or to permit unacceptable thermal expansion perpendicular to the strips. The mask is the subject of our U.S. Patent No. 4,942,332.

An example of the slit mask is one in which the mask is composed of a plurality of grille wires strung in close and parallel proximity between two supports. A mask of this type is the subject of U.S. Patent No. 2,842,696.

Another example of a slit mask is one in which the mask is essentially a parallel array of narrow strips held together only at the ends and stretched over a strong, specially shaped frame so that the tensioned strips form a sector of a cylindrical surface. The tension ensures that all strips remain straight. This design has the disadvantage that each strip is capable of vibrating independently, with very little damping. Conventionally, this deficiency is remedied by stretching one or several small diameter wires or fibers around the cylindrical surface, lightly touching all strips. (See

U.S. Patent No. 3,638,063.)

Another example of the slit mask is one used in a post-mask-deflection color cathode ray tube wherein the mask is in the form of two intercalated combs providing mutually insulated first and second arrays of strips. Each of the arrays is adapted to receive a different electrical potential effective to cause the electron beams passing therethrough to be deflected by the electrical fields created between the strips.

With the exception of the mask comprising a plurality of grille wires described above, masks may be formed from metal foil having thicknesses in the range of 0.00051 cm to 0.00076 cm (0.0002 inch to 0.003 inch). Such foils are non-self-supporting so they must be installed in a highly tensed state. By way of example, the tension of a foil mask for a 29 cm (14-inch) (diagonal measure) tube is about 2100 kg/cm<sup>2</sup> (30 kpsi). The amount of tension that must be applied will vary with the thickness of the foil and the size of the tube in which the mask is installed. Masks also may be formed from metal having a thickness in the range of 0.0076 to .02 cm (0.003 to 0.008 inch) thick, by way of example. Masks made in this range of thickness are largely self-supporting, and while it may be necessary to tense them, the magnitude of the tensing required is relatively lower--typically about 700 kg/cm<sup>2</sup> (10 kpsi), again by way of example, and depending upon the type of mask and the size of the tube in which it is used.

#### Other Prior Art

##### Patents--

U. S. Patent No. 2,905,845 to Vincent

U. S. Patent No. 2,961,560 to Fyler

U. S. Patent No. 3,440,469 to Bradu et al

U. S. Patent No. 3,894,321 to Moore

U. S. Patent No. 4,695,761 to Fendley

French Patent No. 1,477,706, Compagnie de

Saint-Gobain

Japanese Patent No. 56/141,148, Mitsubishi Denki

K.K.

Article--

"The CBS-Colortron: A Color Picture Tube of Advanced Design," Fyler et al. Proceedings of the I.R.E., October 27, 1953.

It is a general aim of the invention to provide a color cathode ray tube having a curved faceplate with a tensed shadow mask and to provide certain benefits of the flat tension shadow mask tube to such color cathode ray tubes with a curved faceplate.

The present invention therefore provides a tension mask color cathode ray tube having a faceplate with curved outer and inner surfaces, and with a tensed shadow mask located adjacent to said inner surface and secured to discrete mask support rails affixed to said inner surface, said rails having a curvature related to the curvature of said inner surface.

The present invention further provides a tension mask color cathode ray tube having a cylindrical, skirted faceplate curved on a single axis oriented in the vertical direction, said faceplate having on its inner surface a centrally located screen with only two discrete support rails affixed to said inner surface and located on opposed sides said screen, said rails aligned in a horizontal direction and having a curvature related to the curvature of said inner surface, said rails providing for receiving and securing a shadow mask tensed in the vertical direction adjacent to said screen.

One of the features of the invention is to provide a tensed shadow mask color cathode ray tube with a faceplate that has a greater resistance to atmospheric pressure than a flat faceplate.

Further features and advantages of the invention, may best be understood by reference to the following

description of preferred embodiments of the invention taken in conjunction with the accompanying drawings (not to scale), in the several figures of which like reference numerals identify like elements, and in which:

Figure 1 is a side view in perspective of a tension mask color cathode ray tube having a curved faceplate according to the invention; cutaway sections indicate the location and relationship of the major components of the tube.

Figure 2 is a plan view of the front assembly of the color cathode ray tube of figure 1 taken from the aspect of the electron gun, and with parts cut away to show the relationship of the shadow mask with the faceplate and screen; an inset depicts the apertures (greatly enlarged) of a slot-type shadow mask.

Figure 3 is a perspective view of the front assembly shown by figures 1 and 2, depicting discrete mask support rails affixed to the inner surface of the faceplate and having a curvature related to the curvature of the screen.

Figure 4 is a view in elevation of the cross-section of the mask support rails depicted in figures 1-3.

Figure 5 is a perspective view of a front assembly of a color cathode ray tube according to the invention in which the faceplate has a skirt.

Figure 6 is a view in elevation showing the curvature of shadow mask support structure that provides for a predetermined variation in Q-height.

Figure 7 is a perspective view of a prior art slot-type shadow mask for use in a color cathode ray tube according to the invention.

Figure 8 is a view in perspective that depicts a section, greatly enlarged, of the prior art slot mask shown by figure 7.

Figure 9 is a detail view of a mask comprising a

plurality of grille wires.

Figure 10 is a view in perspective showing a representative section of a mask that provides post-mask beam deflection; and

Figure 11 is a view in perspective of a representative section of a mask comprising a plurality of parallel strips.

A curved-faceplate tension mask color cathode ray tube and its components is shown in figures 1-3, and is described in the following paragraphs in this sequence: reference number, a reference name, and a brief description of structure, interconnections, relationship, functions, operation, and/or result, as appropriate.

- 20 tension mask color cathode ray tube
- 22 front assembly
- 24 glass faceplate curved according to the invention; the x- and y-axis of a faceplate are indicated in figures 2 and 3; in the following exposition, an orientation along the x-axis of the faceplate is referred to as "the horizontal direction" and an orientation along the y-axis is referred to as "the vertical direction"
- 26 inner surface of faceplate 24
- 28 outer surface of faceplate 24
- 30 centrally disposed phosphor screen consisting of a pattern of spaced vertical lines comprising a sequence of red-light-emitting, green-light-emitting and blue-light-emitting phosphors, the lines relating to the pattern of the slits or slots of the shadow mask 40 (described below); the lines are interspersed by a grille, or "black surround"
- 32 film of aluminum deposited over screen
- 34 funnel
- 36 peripheral sealing area of faceplate 24, adapted to mate with the peripheral sealing area of funnel 34
- 38a, 38b discrete shadow mask support rails that are affixed to the inner surface 26 of faceplate 24; the two

structures are located on opposed sides of the screen 30  
40 foil shadow mask; the mask is mounted in tension  
of the mask support rails 38a and 38b by securing the mask  
aprons 40a and 40b to the support rails 38a and 38b; the  
apertures of the mask are depicted in the inset 42 as  
being distinctive of a slot mask

44 internal magnetic shield

46 internal conductive coating on funnel 34

48 anode button

50 high-voltage conductor

52 neck of tube

54 in-line electron gun enclosed in neck 52; gun 54  
provides three discrete in-line beams 56, 58 and 60 for  
exciting the lines of red-light-emitting,  
green-light-emitting, and blue-light-emitting phosphors on  
screen 30

62 base of tube

64 metal pins for conducting operating voltages and  
video signals through base 62 to electron gun 54

66 yoke which provides for the traverse of beams 56,  
58 and 60 across screen 30.

With reference to figure 3, shadow mask 40, noted  
as being in a tensed condition, is located adjacent to  
inner surface 26 of faceplate 24, indicated as being  
skirtless, and centrally located line screen 30. Mask 40  
is secured to the discrete mask support rails 38a and 38b  
which are affixed to inner surface 26, and have a  
curvature related to the curvature of inner surface 26.  
The curvature of faceplate 24 will be noted as a curvature  
with respect to a single axis oriented in the vertical  
direction. Mask 40 is noted as being tensed in a vertical  
direction.

The discrete mask support rails 38a and 38b  
comprise two rails located on opposed sides of centrally  
located screen 30. Rails 38a and 38b are aligned in a  
horizontal direction.

Figure 4 is a detail view of the cross-section of rail 38a as mounted on faceplate 24 (rail 38b has the same structure). The discrete rail 38a is affixed to the inner surface 26 of faceplate 24 by devitrified solder glass, the overflow of which is indicated by beads 70 and 72. A mask 40 is shown diagrammatically as being tensed by a mask-tensing fixture 74, with the direction of tensing indicated by arrow 76.

The body of rail 38a is indicated symbolically as being composed of a ceramic. The function, structure and composition of the mask support rail 38a and its counterpart 38b is the subject of the aforesaid U.S. Patent No. 4,891,546. The mask support could as well comprise an all metal rail such as the mask support structure that is the subject of our U.S. Patent No. 4,891,544.

A factory fixture frame that provides for mounting and tensing a shadow mask is described and claimed in our U.S. Patent No. 4,790,786. The frame described in the patent is designed to stretch a mask in both the horizontal and vertical directions; a simple modification of the apparatus will provide for stretching a mask, such as mask 40, in a single direction, such as the vertical direction.

With reference also to figure 2, the apron 40a of the mask 40 is shown in contact with a first surface 80 of the metal cap 82 of rail 38a. A high-energy welding beam 84, indicated by the dotted line as being a pulsed beam, provides for welding the apron 40a of mask 40 to first surface 80 of rail 38a while mask 40 is under the tension provided by mask-tensing fixture 74. The welding line 86, which runs the entire length of rail 38a (and 38b), is indicated by the pattern of dots shown on apron 40a in figure 2.

When the welding of the apron 40a of mask 40 is completed, the high-energy beam is moved outwardly and

becomes a continuous-wave mask-trimming beam 88 of higher power, indicated by the solid line. Mask-trimming beam 88 is focused on a trimming line 90 for severing the mask and releasing the front assembly 22 from the mask-stretching fixture 74. With reference again to figure 2, the trimming line 90 follows the approximate path of the dashed line shown.

The means and process for welding a foil mask to a support structure by a high-energy beam, and severing the mask, are fully described in our U.S. Patent No. 4,828,523. During the severing of mask 40 at trimming line 90, the high-energy mask-trimming beam will overshoot and strike the inner surface 26 of the faceplate 24, causing spalling and cracking of the glass. To prevent this, rail 38a has a second surface 92 which slopes outwardly and downwardly toward the inner surface 26 of faceplate 24 to define a non-zero angle in range of 40 to 50 degrees relative to inner surface 26. Second surface 92 intercepts and reflects mask-trimming beam 88 away from the inner surface 26 of faceplate 24, as indicated by the associated arrow.

The same mask welding and trimming operation also applies to counterpart rail 38b.

The shadow mask 40 shown is the tension mask described and claimed in the aforesaid U.S. Patent No. 4,942,332. With reference again to figure 2 and the detail shown by inset 42, mask 40 comprises a series of parallel strips 100 separated by slits 102. Strips 100 are loosely coupled by widely spaced ties 104. As noted, and as indicated by figures 2 and 3, the mask is tensed uniaxially; in this case, tensed in the vertical direction. A foil mask as defined in this application requires a uniaxial tension of about  $2100 \text{ kg/cm}^2$  (30 kpsi); there is no tension in the horizontal direction, and (with reference to figure 2) there is no need to support the borders 106 and 108 of the mask with

additional rails. A thicker mask would require less tension; i.e., about  $700 \text{ kg/cm}^2$  (10 kpsi), and in its cylindrical form, would be more self-supporting than a mask composed of a thinner foil. As noted, the magnitude of tension is also a function of the size of the cathode ray tube in which it is used.

Figure 5 depicts a front assembly for a tension mask color cathode ray tube having a cylindrical faceplate 112 with a curved inner surface 114, a curved outer surface 116, and a foil shadow mask 118 located adjacent to inner surface 114. Mask 118 is tensed in the vertical direction and is secured to discrete mask support rails 120a and 120b affixed to the inner surface 114, and are aligned in the horizontal direction on faceplate 112. Faceplate 112 has a skirt 122 according to the invention.

Figure 6 is a diagrammatic depiction of the profile of an alternate embodiment of a rail 123 as mounted on a faceplate 125. The rail 123 is shown as having a predetermined variance in Q-height according to the invention. By way of example, and as indicated by the associated arrows, the Q-height of rail 123 at its center 124 is shown as being relatively lower than the Q-height of the rail 123 at the corners 126 and 128.

Figure 7 depicts the configuration of a prior art slot mask 130 described heretofore. Figure 8 depicts a detail of the structure of slot mask 130 in which the slots 132 are bridged by tie bars 134 at frequent intervals. As noted, because of the high density of the tie bars 134, the mask has a substantial mechanical strength in the transverse direction; that is, at right angles to the major axis of the slots.

As indicated by its curved condition, slot mask 130 can be installed adjacent to the inner surface of a cylindrical faceplate curved on a single axis and secured to discrete mask support rails affixed to the inner surface of the faceplate. With reference to figure 3, the

slot mask 130 can be installed in place of the mask 40. Slot mask 130 can be tensed in the vertical direction with a tension of about  $700 \text{ kg/cm}^2$  (10 kpsi), by way of example, and its thickness could be in the range about 0.015 cm (0.006 inch), also by way of example. Because of its thickness and its mechanical strength in the transverse direction, mask 130 is largely self supporting, and there would be no need to provide support for the borders 136 and 138 of mask 130, as by additional mask support rails.

With reference to figure 9, there is depicted schematically a mask 142 comprising a plurality of grille wires 144 tensed in a vertical direction (the y-direction) between two mask support structures 146a and 146b.

Figure 10 is a depiction of a representative section 150 of a mask support structure and two arrays of metal strips that provide for post-mask deflection of the electron beams. A ceramic mask support structure 152 has on its top surface 154 a pattern of metallized areas 156 made of a weldable material such as nickel, and having sufficient thickness to permit welding foil mask strips 158, 160 and 162 to the respective metallized areas 156, as indicated by the weld symbols (\*). In the manufacturer of the mask, the metal strip 160 is severed from the apron 164 that joins all strips together at the ends, forming a gap 166 that electrically isolates strip 160 from adjoining strips 158 and 162. As a result, this shadow mask is in the form of two intercalated combs providing physical separation and mutually insulated first and second arrays of metal strips each adapted to receive a different electrical potential. The difference in potential of the two arrays is effective to cause electron beams passing therethrough to be deflected by the electrical fields created between the strips; as a result, it is termed a "bipotential" shadow mask that provides for post-mask deflection.

A similar structure is depicted in figure 11, except that there is no gap between metal strips 170, 172 and 174. As a result, there is no difference in electrical potential; hence the mask is unpotential "strip mask" that provides acceleration of the electron beams passing therethrough, but provides no post-mask beam deflection. The structure is simplified in that the discrete metallized areas 156 shown by figure 10 can comprise the continuous strip of metal 176 indicated. This strip-mask structure is also installable in the color cathode ray tube having a curved faceplate according to the present invention.

While a particular embodiment of the invention has been shown and described, it will be obvious to those skilled in the art that changes and modifications may be made in the inventive means without departing from the invention in its broader aspects, and therefore, the aim of the appended claims is to cover all such changes and modifications as fall within the scope of the invention.

CLAIMS

1. A tension mask color cathode ray tube having a faceplate with curved outer and inner surfaces, and with a tensed shadow mask located adjacent to said inner surface and secured to discrete mask support rails affixed to said inner surface, said rails having a curvature related to the curvature of said inner surface.
2. The tube of claim 1 wherein the curved inner surface of the tube has a centrally located screen, and wherein the discrete mask support rails are affixed to said inner surface on opposed sides of said screen.
3. The tube of claim 2 wherein said discrete mask support rails consist of only two rails located on opposed sides of said screen and aligned in a horizontal direction.
4. The tube of claim 1, 2 or 3 wherein the curvature of said faceplate is with respect to a single axis oriented in the vertical direction.
5. The tube of claim 1, 2 or 3 wherein said mask is tensed only in the vertical direction.
6. The tube of claim 1, 2 or 3 wherein said faceplate is skirtless.
7. The tube of claim 1, 2 or 3 wherein said faceplate has a skirt.
8. The tube of claim 1, 2 or 3 wherein said rails have a predetermined variance in Q-height.
9. The tube of claim 1, 2 or 3 wherein said mask is a slot mask, and wherein the strips comprising the mask are interconnected by ties at frequent intervals.
10. The tube of claim 1, 2 or 3 wherein said mask is a mask comprising a series of parallel strips separated by slits, the strips being loosely coupled by widely spaced ties.
11. The tube of claim 1, 2 or 3 wherein said mask comprises a plurality of grille wires.
12. The tube of claim 1, 2 or 3 wherein said

mask is a bipotential mask comprising an intercalated array of metal strips that provides for post-mask deflection of electron beams.

13. The tube of claim 1, 2 or 3 wherein said mask is a unipotential mask comprising an array of metal strips.

14. A tension mask color cathode ray tube having a cylindrical, skirted faceplate curved on a single axis oriented in the vertical direction, said faceplate having on its inner surface a centrally located screen with only two discrete support rails affixed to said inner surface and located on opposed sides said screen, said rails aligned in a horizontal direction and having a curvature related to the curvature of said inner surface, said rails providing for receiving and securing a shadow mask tensed in the vertical direction adjacent to said screen.

15. The tube of claim 14, wherein the support rails are aligned in a horizontal direction and the shadow mask comprises a slot mask having tie bars at frequent intervals and wherein the slot mask is secured to the opposed rails.

16. The tube of claim 14, wherein the support rails are aligned in a horizontal direction and the shadow mask comprises a series of strips separated by slits, with the strips loosely coupled by widely spaced ties and with the strips secured to the opposed rails.

17. The tube of claim 14, wherein the support rails are aligned in a horizontal direction and the shadow mask comprises a plurality of grille wires secured to the opposed rails.

18. The tube of claim 14, wherein the support rails are aligned in a horizontal direction and the shadow mask comprises a bipotential mask having intercalated arrays of metal strips that provide for post-mask deflection and which strips are secured to the opposed rails.

19. The tube of claim 14, wherein said support rails are aligned in a horizontal direction and said shadow mask comprises a unipotential mask having an array of metal strips secured to the opposed rails.

1 / 4

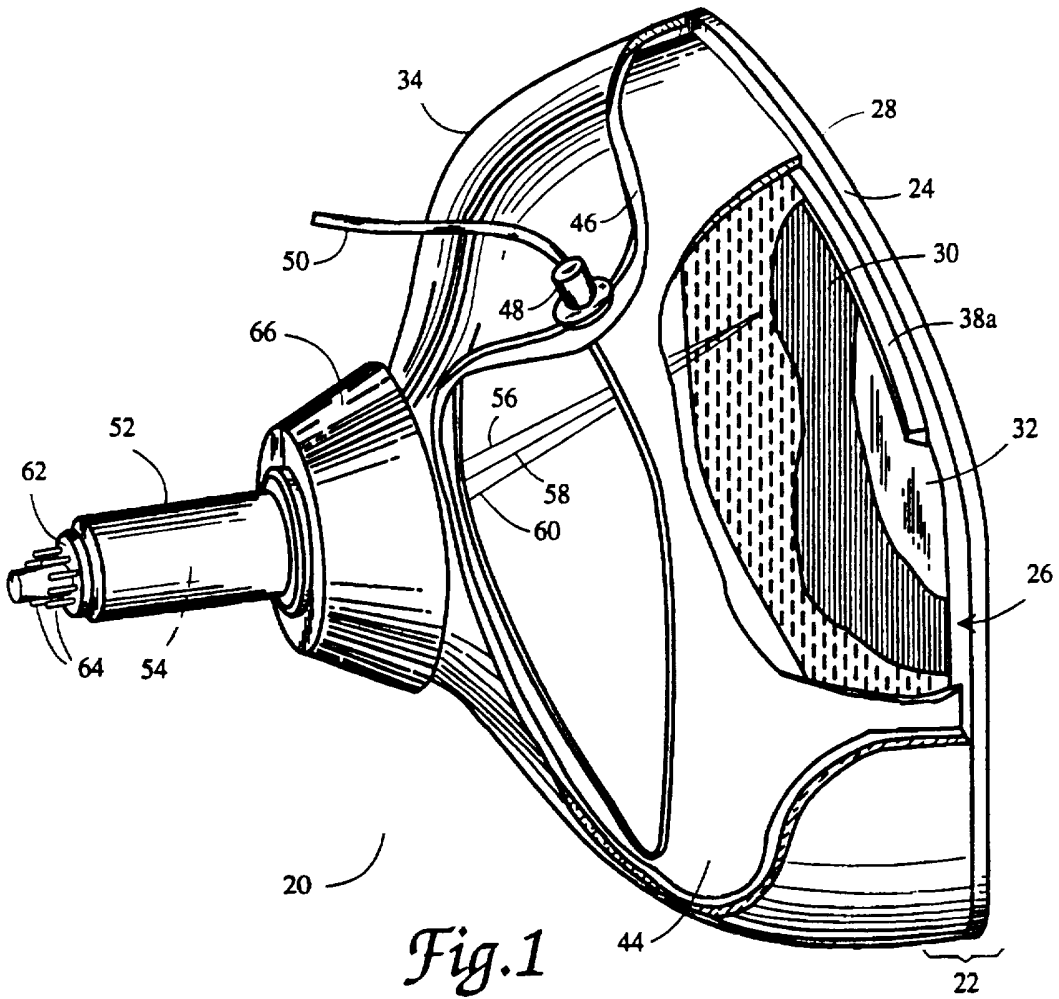

Fig. 1

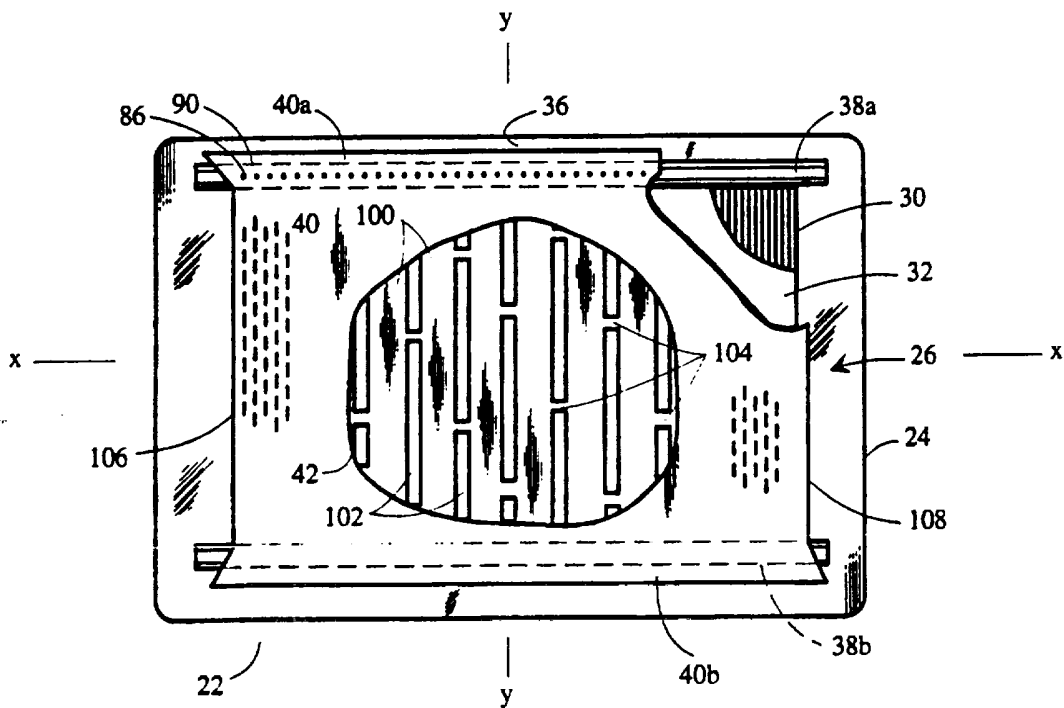

Fig. 2

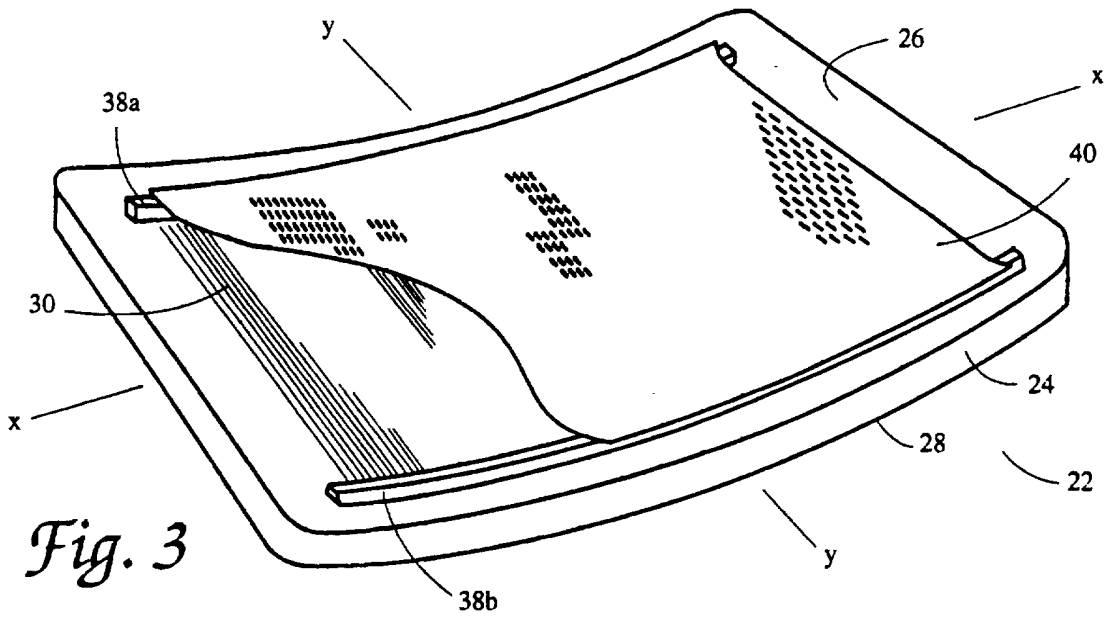

Fig. 3

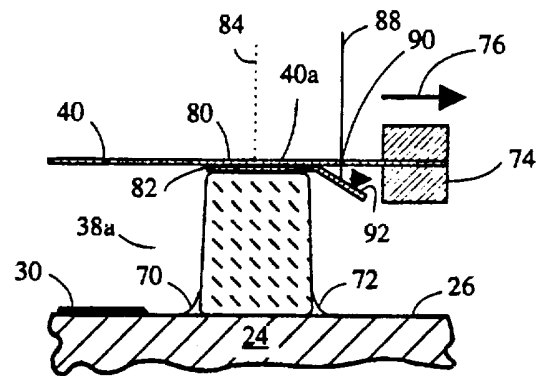

Fig. 4

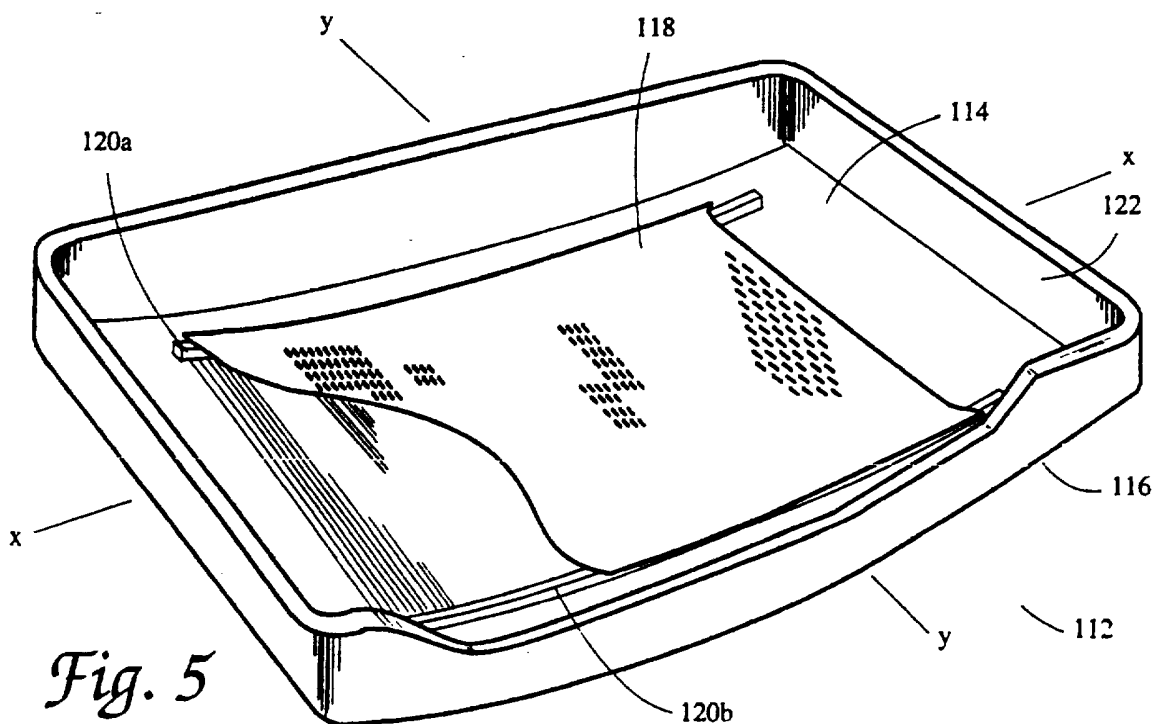

Fig. 5

3 / 4

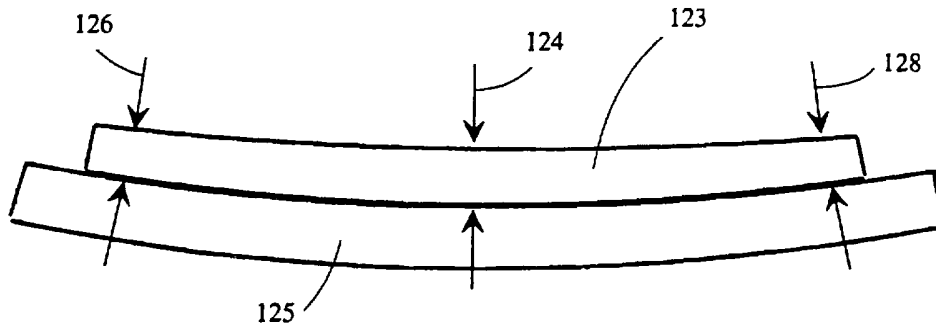

Fig. 6

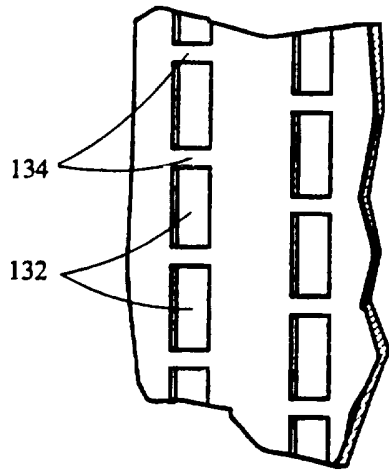

Fig. 7  
(PRIOR ART)

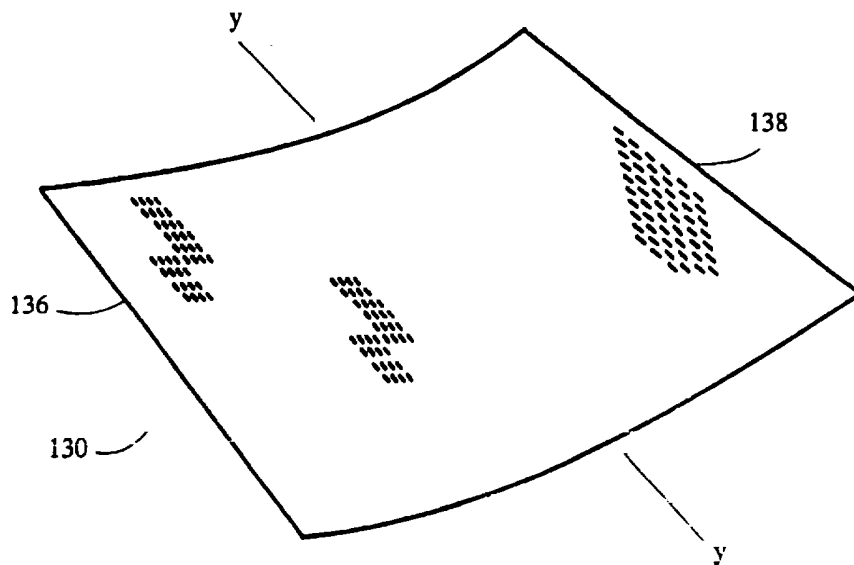
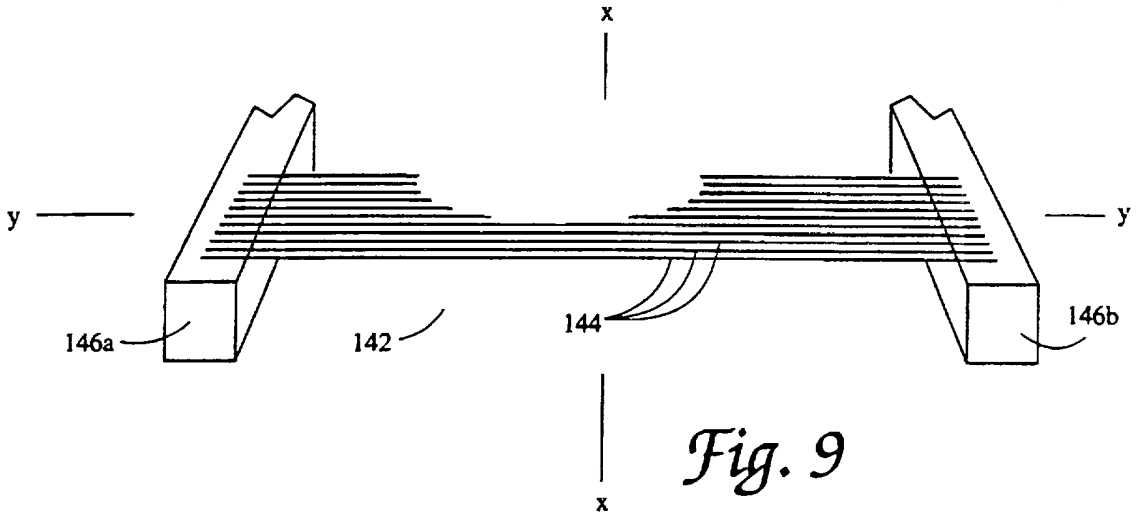
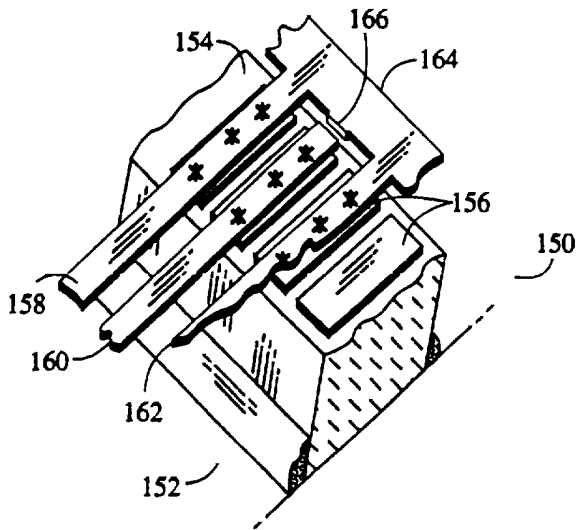

Fig. 8

**SUBSTITUTE SHEET**



*Fig. 9*



*Fig. 10*

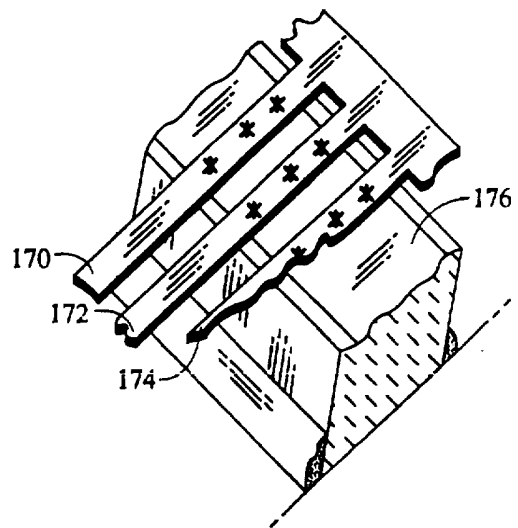

*Fig. 11*

**SUBSTITUTE SHEET**