



(22) **Date de dépôt/Filing Date:** 2009/02/27

(41) **Mise à la disp. pub./Open to Public Insp.:** 2009/08/29

(45) **Date de délivrance/Issue Date:** 2016/06/14

(30) **Priorité/Priority:** 2008/02/29 (GB0803873.9)

(51) **Cl.Int./Int.Cl.** G01V 13/00 (2006.01)

(72) **Inventeurs/Inventors:**
PEARSON, RICHARD DAVID, GB;
CONWAY, KEVIN, GB

(73) **Propriétaire/Owner:**
RADIODETECTION LIMITED, GB

(74) **Agent:** ROBIC

(54) **Titre :** DETECTEUR DE CONDUCTEUR DE COURANT ET METHODE DE VALIDATION DU DETECTEUR

(54) **Title:** A DETECTOR FOR DETECTING A CURRENT CARRYING CONDUCTOR AND A METHOD OF VALIDATING OPERATION OF THE DETECTOR

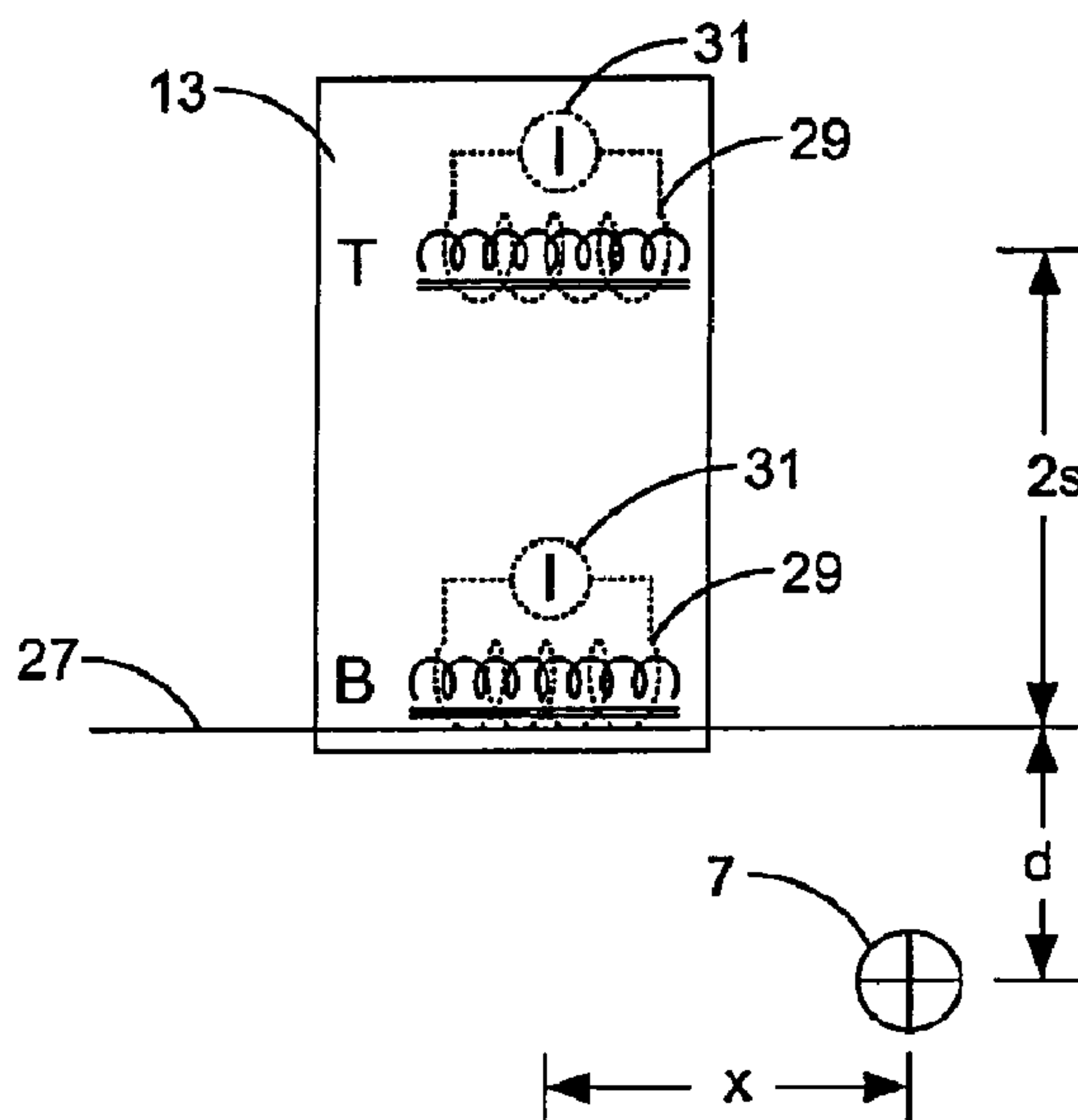

(57) **Abrégé/Abstract:**

A detector 5 for detecting a buried conductor 7 comprises a plurality of antennas B, T. Each antenna B, T has a winding 29 wound around the antenna, the winding 29 being connected to a current source 31 for providing a predefined current in the winding 29. When the predefined current is applied to the winding 29 an electromagnetic field is generated at the antenna which induces a test current in the antenna. The test current is compared to calibration data stored in the detector 5 to validate the correct operation of the detector 5.

ABSTRACT:

A detector 5 for detecting a buried conductor 7 comprises a plurality of antennas B, T. Each antenna B, T has a winding 29 wound around the antenna, the winding 29 being connected to a current source 31 for providing a predefined current in the winding 29. When the predefined current is applied to the winding 29 an electromagnetic field is generated at the antenna which induces a test current in the antenna. The test current is compared to calibration data stored in the detector 5 to validate the correct operation of the detector 5.

A detector for detecting a current carrying conductor and a method of validating operation of the detector

Field of the invention

The present invention relates to a detector for detecting a current carrying conductor and a method of validating operation of the detector.

10

Background of the invention

Before commencing excavation or other work where electrical cables, fibre optic cables or other utilities ducts or pipes are buried, it is important to determine the location of such buried cables or pipes to ensure that they are not damaged during the work.

Current carrying conductors emit electromagnetic radiation which can be detected by an electrical antenna. If fibre optic cables or non-metallic utilities ducts or pipes are fitted with a small electrical tracer line, an alternating electrical current can be induced in the tracer line which in turn radiates electromagnetic radiation. It is known to use detectors to detect the electromagnetic field emitted by conductors carrying alternating current.

20

Once a buried utility is located the depth of the utility can be calculated to determine a safe excavation depth. It is important that the depth information provided to the operator is accurate so as to avoid damage to the buried utility or injury to person when excavating the area.

In this application we describe an improved detector for detecting a buried conductor which provides the user with a depth reading with improved integrity. A method is described for validating operation of the detector.

Summary of the invention

According to a first aspect of the invention there is provided a system for detecting a buried conductor, comprising:

a detector, including:

a plurality of antennas for detecting an electromagnetic field,

a plurality of windings, each wound around a respective antenna, each winding being connected to a current source for providing a predefined current in the winding to generate an electromagnetic field at the antenna, thereby inducing a test
10 current in the antenna,

a memory for storing calibration data of the antennas,

a processor configured to process the test currents in the antennas to determine if the test currents are within predetermined limits of the calibration data, and a communications module for transmitting calibration test results; and

a microprocessor-controlled device for receiving the calibration test results from the detector.

The predetermined limits for each antenna may be the calibration data $\pm 0.01\%$.

The processor may be configured to disable the detector if one of the test currents is outside the predetermined limits of the calibration data.

20 The plurality of antennas may comprise two or three parallel antennas which in use are oriented horizontally and spaced vertically.

The processor may be configured to store results of the test in the memory.

The detector may further comprise a user interface for conveying the results of the test to a user and a communications module for transmitting results of the test to another device.

According to a second aspect of the invention there is provided a method of validating the operation of a detector for detecting a buried conductor, the detector including a plurality of antennas, a plurality of windings, each winding wound around a respective antenna and connected to a current source, a memory, a processor and a communications module, the method comprising:

providing a predefined current in the winding to generate an electromagnetic field at each antenna, thereby inducing a test current in each antenna;

processing the test currents to determine if the test currents are within predetermined limits of the calibration data; and

10 transmitting calibration test results from the detector to a microprocessor-controlled device.

The predetermined limits for each antenna may be the calibration data $\pm 0.01\%$. The processor may disable the detector if one of the test currents is outside the predetermined limits of the calibration data.

The plurality of antennas may comprise two or three parallel antennas which in use are oriented horizontally and spaced vertically.

The processor may store results of the test in the memory and the test may be conveyed to a user via a user interface.

20 The method may further comprise: providing the detector with a communications module; providing a microprocessor-controlled device having a communications module for communicating with the communications module of the detector; and transmitting the results of the test from the detector to the microprocessor-controlled device via the communications modules.

The method may further comprise: providing the microprocessor-controlled device with a communications module for accessing a network; and transmitting results of the test from the microprocessor-controlled device to said network.

The method may further comprise: providing a server connected to said network; and transmitting results of the test from the microprocessor-controlled device to the server over said network.

The method may further comprise: generating a calibration certificate at the server if the test results indicate that the detector is operating within predetermined limits and downloading the calibration certificate from the server to the microprocessor-controlled
10 device. The network may be the Internet.

The detector described above may further comprise a housing in which the other components of the detector are housed, wherein the detector is portable.

Brief description of the drawings

Figure 1 is a schematic representation of a detector system for detecting a buried conductor according to an embodiment of the invention;

Figure 2 is a block diagram of the detector of the system of Figure 1;

Figure 3 is a representation of two antennas of the detector of Figure 2; and

Figure 4 shows a system for validating operation of the detector of Figure 2.

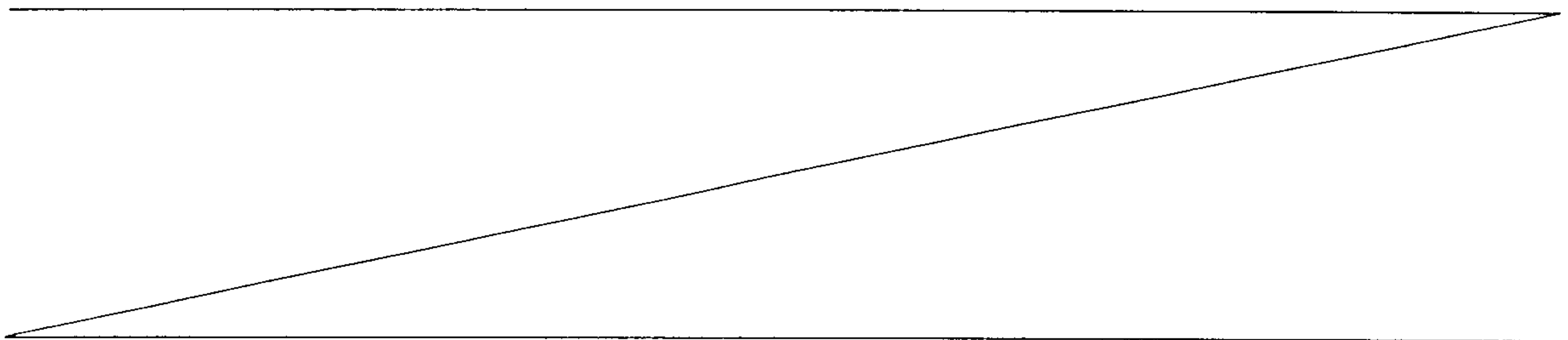

Description of preferred embodiments

Figure 1 is a schematic representation of a system 1 for detecting a buried conductor according to an embodiment of the invention, comprising a portable transmitter 3 and a portable receiver/detector 5. The transmitter 3 is placed in proximity to a buried conductor 7 to produce an alternating current test signal in the buried conductor 7.

10 An aerial in the transmitter 3 is fed with an AC voltage to produce an electromagnetic field 9 which links with the buried conductor 7, thereby inducing the alternating current test signal in the buried conductor 7. The alternating current test signal is radiated as an electromagnetic field 11 by the buried conductor 7 and this electromagnetic field can be detected by the receiver 5. In other embodiments the transmitter may provide a test signal in the conductor by direct connection to the conductor or by clamping around the conductor, as is known in the art.

20 Figure 2 is a block diagram of the receiver 5 of the system 1 of Figure 1. An electromagnetic field 11 radiated by the buried conductor 7 is detected by a plurality of antennas in an antenna module 13. Each antenna outputs a field strength signal representative of the electromagnetic field 11 at the antenna. The outputs from the antenna module 13 are fed into a signal processor module 15 for isolating signals of a desired frequency band or bands and processing these signals to derive their characteristics using known techniques. The signal processor module 15 may comprise a pre-amplification stage for amplifying the field strength signals output from the antennas if the detected signal is weak. The signal processor module 15 may further comprise an analogue to digital converter for converting the field strength signals into digital signals and a digital signal processor for processing the digitised signals.

The receiver comprises a communications module 17 to provide a communication/data link between the receiver 5 and a microprocessor-controlled device such as a personal computer (PC) or a personal digital assistant (PDA) (not shown). The communication link may be implemented via a wired or wireless connection. Additionally the communications module 17 may provide a communication link with the transmitter 3.

A user interface module 19 is provided to convey information to the operator of the receiver 5 and may comprise one or more of a display for displaying information to the operator of the device, input devices such as a keypad or a touch sensitive screen and an audible output device such as a speaker or beeper. The receiver 5 further comprises a memory module 21 and a power supply unit (PSU) 23 comprising power management circuitry and a power source such as batteries. The overall control of the various components of the receiver 5 is managed by a controller 25.

10

When the receiver is located over a current carrying conductor which radiates an electromagnetic field, the depth of the conductor can be calculated using known techniques by comparing the current induced in at least two of the antennas in the antenna module 13. Figure 3 shows an antenna module 13 of a detector 5 comprising two horizontal vertically spaced antennas B, T. In use the detector 5 is held vertical on ground 27 in which a current carrying conductor 7 is buried, with the bottom antenna B close to the surface of the ground 27. The axes of the antennas are parallel and the separation between the bottom antenna B and the top antenna T is $2s$. The conductor 7 is buried at a depth d below the surface of the ground 27 (and below the bottom antenna B) and the horizontal displacement between the antennas B and T and the conductor 7 is x . The components of the portable detector 5 are housed in a housing (not shown).

20

When an alternating current flows in the conductor 7 and the conductor 7 radiates an electromagnetic field, the magnetic flux density or magnetic field at the bottom antenna B is B_B and the magnetic flux density at the top antenna T is B_T . The depth of the buried conductor 7 below the surface 27 of the ground is given by:

$$d = \frac{2s}{\frac{B_B(x, d)}{B_T(x, d)} - 1}$$

It can be seen from the above equation that in order to produce an accurate depth calculation the outputs from the bottom antenna B and the top antenna T must be correctly calibrated with respect to each other. The calibration of the top antenna T relative to the bottom antenna B is performed when the detector is set up after

manufacture and factory calibration data is stored in the memory 21. This invention provides a detector which can perform a self-test to ensure that the calibration of the antennas is within acceptable limits and a method of validating the operation of the detector.

10 In the detector 5 of Figures 2 and 3 each antenna B, T is provided with a winding 29 (shown in dotted lines) which is wound around the ferrite of the antenna and connected to a precision current source 31 (shown in dotted lines) to provide an integrated built-in test capability. After the relative calibration of the top antenna T and the bottom antenna B is performed in the factory, separate calibration data is generated in the factory for the top antenna T and for the bottom antenna B by using the precision current source 31 of each antenna to generate a known, predefined current in the winding 29 and recording the current induced in the antennas B, T. This calibration data is stored in the memory 21 of the detector 5 so that it is available for future calibration self-tests.

20 If it is desired to check that the detector 5 is still performing within its calibration limits then the user initiates the calibration procedure through the user interface 19. The predefined test current is generated by the precision current sources 31 and passed through the windings 29 to produce electromagnetic fields at the antennas B, T which induces test currents in the respective antennas B, T. The test currents output from the antennas B, T are compared to the factory calibration data stored in the memory 21 for each antenna B, T to verify that the currents are within predetermined limits of the factory calibration data. If the currents output from both of the antennas B, T are within the predetermined limits then the calibration test is deemed to be a pass. The predetermined limit for each antenna is that the test current is within the factory calibration data $\pm 0.01\%$ (i.e., 1 part in 10,000). If the current output from one of the antennas B, T is not within the predetermined limits then the calibration test is deemed to be a fail. The results of the integrated built-in test are conveyed to the user by means of the user interface 19 and stored in the memory 21. If the detector 5 fails the integrated built-in test then a warning is displayed to indicate that the detector 5 is out of calibration. Alternatively or additionally the controller 25 may lock the detector 5 to prevent its use until the detector is recalibrated and the integrated built-in test is passed.

Figure 4 shows a system for validating the operation of the detector of Figure 2. The detector 5 communicates via its communications module 17 with a communications module of a PC 33, a PDA 35 or other microprocessor-controlled device (not shown). In the system of Figure 4 the detector 5 communicates wirelessly with the PC 33 and PDA 35 but in other embodiments the detector 5 may communicate via a wired connection.

The PC 33 and PDA 35 are connected or connectable via a network 37, such as the Internet, to a server 39. The server 39 can access a storage device 41.

10

The results of the calibration test together with an identifier of the detector 5, such as a serial number, can be uploaded from the memory 21 of the detector 5 to the PC 33 or PDA 35 and from there via the network 37 to a server 39 so that the results can be stored in the memory 41 associated with the server 39 to record the test results and whether the detector 5 passed or failed the calibration test on the date in question. If the calibration test was passed then the server 39 can generate a test pass certificate which can be downloaded to the PC 33 or PDA 35. A printer 43 connected to the PC 33 can print the calibration certificate to show that the detector 5 passed the calibration test on the date in question.

20

Various modifications will be apparent to those in the art and it is desired to include all such modifications as fall within the scope of the accompanying claims.

For example, the detector 5 shown in the Figures comprises two parallel horizontal antennas. It will be understood by a person skilled in the art that the detector may comprise three parallel horizontal antennas or more and that some or all of the antennas may comprise a winding wound around the ferrite of the antenna and connected to a precision current source to provide an integrated built-in test capability for some or all of the antennas.

Aspects of the present invention can be implemented in any convenient form, for example using dedicated hardware, or a mixture of dedicated hardware and software.

The processing apparatuses can comprise any suitably programmed apparatuses such as a general purpose computer, personal digital assistant, mobile telephone (such as a WAP or 3G-compliant phone) and so on. Since the present invention can be implemented as software, each and every aspect of the present invention thus encompasses computer software implementable on a programmable device. The computer software can be provided to the programmable device using any conventional carrier medium. The carrier medium can comprise a transient carrier medium such as an electrical, optical, microwave, acoustic or radio frequency signal carrying the computer code. An example of such a transient medium is a TCP/IP signal carrying computer code over an IP network, such as the Internet. The carrier medium can also comprise a storage medium for storing processor readable code such as a floppy disk, hard disk, CD ROM, magnetic tape device or solid state memory device.

10

20

WHAT IS CLAIMED IS:

1. A system for detecting a buried conductor, comprising:
a detector, including:
 - a plurality of antennas for detecting an electromagnetic field,
 - a plurality of windings, each wound around a respective antenna, each winding being connected to a current source for providing a predefined current in the winding to generate an electromagnetic field at the antenna, thereby inducing a test current in the antenna,
 - a memory for storing calibration data of the antennas,
 - 10 a processor configured to process the test currents in the antennas to determine if the test currents are within predetermined limits of the calibration data, and a communications module for transmitting calibration test results; and
 - a microprocessor-controlled device for receiving the calibration test results from the detector.
2. The system according to claim 1, wherein the predetermined limits for each antenna are the calibration data $\pm 0.01\%$.
3. The system according to claim 1 or 2, wherein the processor is configured to disable the detector if one of the test currents is outside the predetermined limits of the calibration data.
- 20 4. The system according to any one of claims 1 to 3, wherein the plurality of antennas comprise two parallel antennas which in use are oriented horizontally and spaced vertically.
5. The system according to any one of claims 1 to 4, wherein the plurality of antennas comprise three parallel antennas which in use are oriented horizontally and spaced vertically.

6. The system according to any one of claims 1 to 5, wherein the processor is configured to store results of the test in the memory.
7. The system according to any one of claims 1 to 6, wherein the detector further comprises a user interface for conveying the calibration test results to a user.
8. The system according to any one of claims 1 to 7, further comprising: a transmitter for generating an alternating current test signal in said conductor.
9. The system according to any one of claims 1 to 8, further comprising a server connected to a network, wherein the microprocessor-controlled device transmits the calibration test results to the server over the network.
- 10 10. The system according to claim 9, wherein the server is configured to generate a calibration certificate if the test results indicate that said detector is operating within predetermined limits.
11. The system according to claim 10, wherein the calibration certificate is downloadable from the server to the microprocessor-controlled device.
12. A method of validating the operation of a detector for detecting a buried conductor, the detector including a plurality of antennas, a plurality of windings, each winding wound around a respective antenna and connected to a current source, a memory, a processor and a communications module, the method comprising:
 - providing a predefined current in the winding to generate an electromagnetic field at
20 each antenna, thereby inducing a test current in each antenna;
 - processing the test currents to determine if the test currents are within predetermined limits of calibration data; and
 - transmitting calibration test results from the detector to a microprocessor-controlled device.

13. The method according to claim 12, wherein the predetermined limits for each antenna are the calibration data $\pm 0.01\%$.
14. The method according to claim 12 or 13, further comprising disabling the detector if one of the test currents is outside the predetermined limits of the calibration data.
15. The method according to any one of claims 12 to 14, wherein the plurality of antennas comprise two parallel antennas which in use are oriented horizontally and spaced vertically.
16. The method according to any one of claims 12 to 15, further comprising storing the calibration test results in the memory.
- 10 17. The method according to any one of claims 12 to 16, further comprising conveying the calibration test results to a user via a user interface.
18. The method according to any one of claims 12 to 17, further comprising: transmitting the calibration test results from the microprocessor-controlled device to a server over a network.
19. The method according to claim 18, further comprising: generating a calibration certificate at the server if the calibration test results indicate that the detector is operating within predetermined limits.
20. The method according to claim 19, further comprising: downloading the calibration certificate from the server to the microprocessor-controlled device.

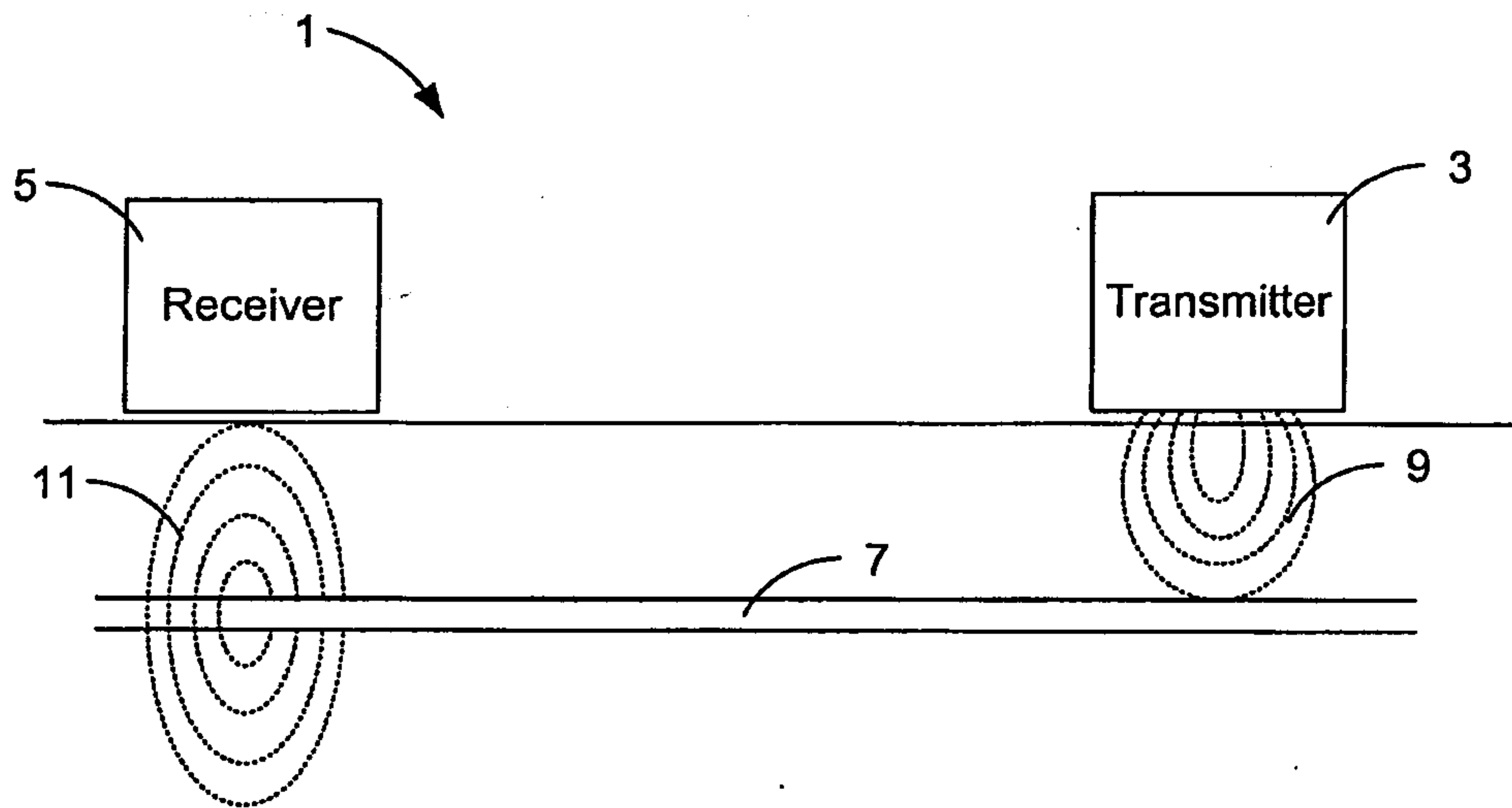

Figure 1

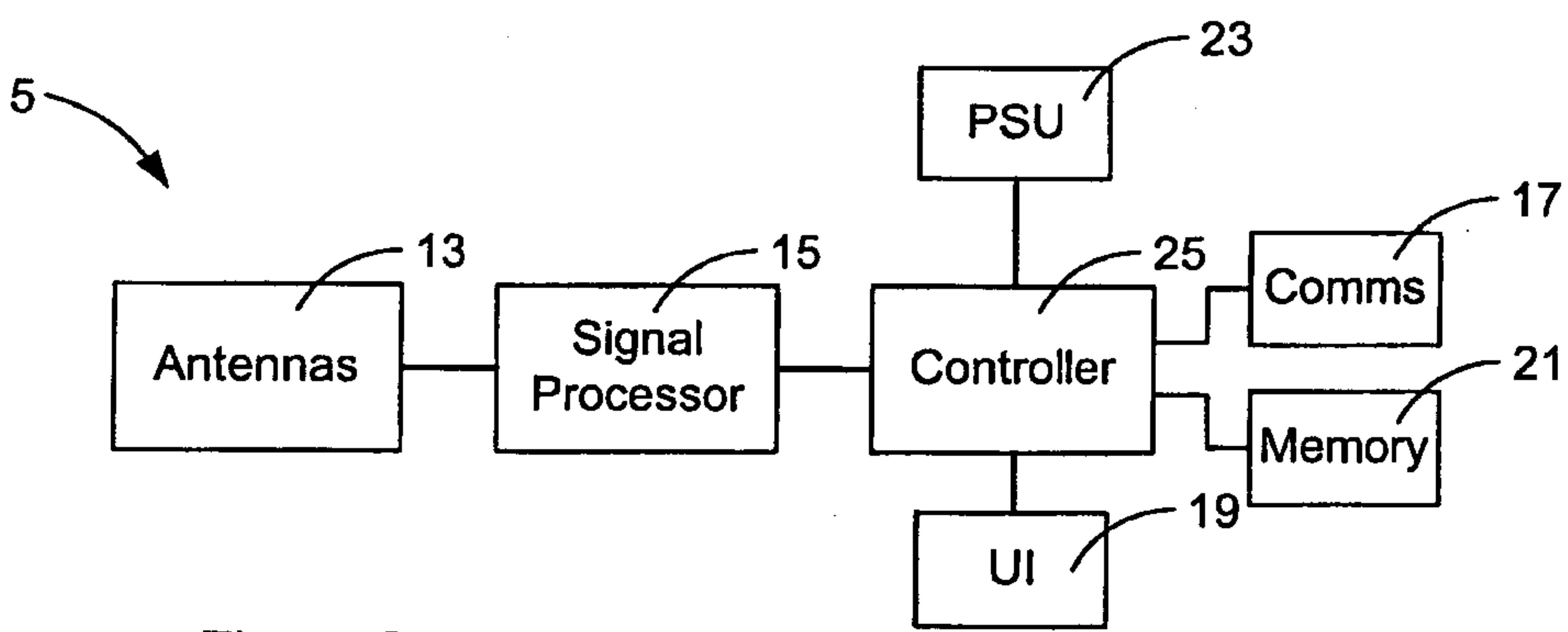

Figure 2

