

(19)



(11)

**EP 4 023 837 B1**

(12)

**EUROPEAN PATENT SPECIFICATION**

(45) Date of publication and mention of the grant of the patent:  
**25.09.2024 Bulletin 2024/39**

(51) International Patent Classification (IPC):  
**E04D 13/08<sup>(2006.01)</sup>**

(21) Application number: **21217513.7**

(52) Cooperative Patent Classification (CPC):  
**E04D 13/08; E03B 2001/047; E04D 2013/0813**

(22) Date of filing: **23.12.2021**

**(54) RAINWATER TRAP TRAPPING THE WATER FROM A GUTTER SYSTEM**

REGENWASSERFANG ZUM AUFFANGEN DES WASSERS AUS EINEM RINNENSYSTEM

PIÈGE À EAU DE PLUIE PIÉGEANT L'EAU À PARTIR D'UN SYSTÈME DE GOUTTIÈRE

(84) Designated Contracting States:  
**AL AT BE BG CH CY CZ DE DK EE ES FI FR GB GR HR HU IE IS IT LI LT LU LV MC MK MT NL NO PL PT RO RS SE SI SK SM TR**

(30) Priority: **31.12.2020 PL 43660820**

(43) Date of publication of application:  
**06.07.2022 Bulletin 2022/27**

(73) Proprietors:  
• **Kubiak, Józef**  
**26-604 Radom (PL)**  
• **Skalska-Kubiak, Jadwiga**  
**26-604 Radom (PL)**  
• **Kubiak, Tomasz**  
**26-604 Radom (PL)**  
• **Kubiak, Julita**  
**60-203 Poznan (PL)**

(72) Inventors:  
• **Kubiak, Józef**  
**26-604 Radom (PL)**  
• **Skalska-Kubiak, Jadwiga**  
**26-604 Radom (PL)**  
• **Kubiak, Tomasz**  
**26-604 Radom (PL)**  
• **Kubiak, Julita**  
**60-203 Poznan (PL)**

(74) Representative: **Patpol Kancelaria Patentowa Sp. z o.o.**  
**Nowoursynowska 162J**  
**02-776 Warszawa (PL)**

(56) References cited:  
**CN-U- 204 551 589 IT-A1- UB20 155 918**  
**US-A1- 2013 248 016**

**EP 4 023 837 B1**

Note: Within nine months of the publication of the mention of the grant of the European patent in the European Patent Bulletin, any person may give notice to the European Patent Office of opposition to that patent, in accordance with the Implementing Regulations. Notice of opposition shall not be deemed to have been filed until the opposition fee has been paid. (Art. 99(1) European Patent Convention).

## Description

**[0001]** The subject of the invention is a rainwater trap trapping the water from the gutter system, enabling the collection of rainwater flowing from the roofs of buildings, intended for filling tanks located above the foundation level of the facilities. The solution is aimed at efficient collection of rainwater and the use of such collected water for irrigation, e.g. in gardens located next to the facilities, which significantly affects water saving. The collected water can also be used for other household and industrial purposes. In addition, which is important in areas flooded by rainwater, the trapping of part of the water and its collection in any place during intense rainfall relieves the rainwater sewage system, reducing the risk of partial inundation or flooding.

**[0002]** The solutions for trapping the rainwater from gutter systems available on the market are limited to trapping rainwater from the rainwater outlet of the gutter by placing a tank and storing it at a level slightly above the ground. Other known solutions consist in incorporating, during the construction of the gutter system, a short section of the pipe with an internal ring that catches water and directs it outside the downpipe. The use of this method is limited to the implementation of the solution during the construction of the gutter system and gutter system is usually built at the stage of building construction or renovation works.

**[0003]** There are also known solutions to be used during the lifetime of the gutter system, which consist in drilling a hole in the gutter downpipe and introducing a plastic fitting into the gutter downpipe, which takes over a part of the rainwater flowing down the downpipe and discharges it outside. This solution seems to be effective with quite intensive precipitation, but not very effective due to low tightness. Moreover, the above-mentioned solution can be fixed at human height, or by using expensive scaffolding. Other known solutions are also rainwater sub-gutter collectors having housings which have a diameter greater than the diameter of the cylindrical rainwater collector tank. These solutions make it possible to collect rainwater using the potential energy of rainwater gravity by a rainwater sub-gutter collector. An example of a gutter system rainwater trap is disclosed in US 2013/248016 A1.

**[0004]** The aim of the invention is to provide a simple, cheap, cost-effective and reliable solution that allows rainwater to be stored and used, inter alia, for irrigation of adjacent gardens, for household purposes, and for any other application, e.g. during periods of absence of owner, and, what is important, without the participation of other energy sources, such as an electric pump.

**[0005]** The rainwater trap trapping the water from the gutter system according to the invention comprises the features of claim 1.

**[0006]** It comprises an overflow stub pipe, inside which a water pipe is placed, and a partition and a pipe for supplying the sealing and fixing agent to the partition are

attached to the outer (side) wall of the overflow stub pipe.

**[0007]** Preferably, the partition is a semi-permeable mesh filled with a sealing and fixing agent.

**[0008]** Preferably, the partition is a rubber torus-tube filled with a sealing and fixing agent.

**[0009]** Preferably, the sealing and fixing agent introduced into the partition by means of the pipe for supplying the sealing and fixing agent is any hardening foam, preferably a polyurethane foam.

**[0010]** Preferably, the sealing and fixing agent introduced into the partition by means of the pipe for supplying the sealing and fixing agent is any agent enabling filling the partition up to the pre-set pressure.

**[0011]** More preferably, the sealing and fixing agent is any gas unaggressive to the rainwater trap materials, for example air, carbon dioxide, argon.

**[0012]** Also more preferably, the sealing and fixing agent is any liquid unaggressive to the rainwater trap materials, for example water.

**[0013]** Preferably, the partition fixes the rainwater trap in the gutter system after the sealing and fixing agent has been introduced by means of the pipe for supplying the sealing and fixing agent, after reaching the planned location in the downpipe.

**[0014]** Preferably, the rainwater trap from the gutter system is installed in a permanent or multiple version, i.e. with the possibility of being dismantled at any time.

**[0015]** Preferably, the overflow stub pipe, the water pipe, the partition and the pipe supplying the sealing and fixing agent to the partition are integrated in such way that they constitute one monolith.

**[0016]** The rainwater trap trapping the water from the gutter system according to the invention can be used at any time of the existence of the gutter system as well as during the construction of the gutter system. It is important because the solution according to the invention can be applied to any facility, to any existing downpipe. It is therefore possible to use this solution on a mass scale without the use of scaffolding or even any tools.

**[0017]** It is worth noting that the number of buildings under construction is about 1 percent compared to the existing ones, which results in low efficiency of solutions that are used only during construction. Thanks to the solution according to the invention intended for existing buildings, it is possible to solve the problem of collecting of the rainwater from all roofs in a short time. This problem is becoming more and more pressing for the present day.

**[0018]** The shortcomings of the existing solutions include the need to laboriously incorporate additional devices into the gutter system already at the construction stage of the building or the rather difficult assembly in existing buildings, including the use of additional scaffolding.

**[0019]** The rainwater trap trapping the water from the gutter system according to the invention is shown and explained in more detail in the embodiment shown in the drawing, in which Fig. 1 shows a vertical section of the gutter system rainwater trap, Fig. 2 shows a vertical sec-

tion of the gutter system rainwater trap after placing it in downpipe, Fig. 3 is a horizontal cross-section of the gutter system rainwater trap placed in the downpipe, and Fig. 4 shows an illustrative application of the solution according to the invention.

**[0020]** As shown in the exemplary embodiments, the partition 3 is realized by placing a set of elements 1, 2, 3, 4 in the vertical downpipe 5, and after placing at the target level in the vertical downpipe 5, the partition is filled by applying a sealing and fixing agent.

**[0021]** The present invention is illustrated by the following embodiment which should not be understood as limiting the scope of the patent protection:

#### Example 1

**[0022]** The gutter system rainwater trap according to the invention comprises an overflow stub pipe 1, inside which a water pipe 2 is placed, while to the outer (side) wall of the overflow stub pipe 1 there is attached a partition 3 and a pipe 4 for supplying sealing and fixing agent to the partition 3. The partition 3 is made of a torus-tube-shaped rubber and is applied to the downpipe 5 in a flaccid form (Fig. 1). After reaching the position at the set height of the downpipe 5 (Fig. 2), the gutter system rainwater trap is brought to the target state by inflating air to the set pressure by means of pipe 4 for supplying the sealing-fixing agent and the invention is maintained in the inflated state throughout the entire operating time (Fig. 2). A person skilled in the art would appreciate that the sealing and fixing agent may be any fluid unaggressive to the particular material parts of the rainwater trap, for example unaggressive gas (air, nitrogen, argon, carbon dioxide) or liquid (for example water). After fulfilling its role, after deflating the air or other sealing and fixing agent, the torus-tube-shaped partition 3 returns to its initial state in a flaccid form (Fig. 1) and the trap according to the invention can be withdrawn from the downpipe 5. Filling and draining of the sealing and fixing agent can be repeated many times. The invention traps the rainwater from the gutter downpipe 5 at any height between the rainwater inlet to the gutter downpipe 5 and the outlet, thereby allowing rainwater to be collected (e.g. in a tank 6 in the form of vessels connected at the level of the capture location or at a lower level (Fig. 4). The gutter system rainwater trap allows to store (collect) rainwater at a significant height, including the level chosen by installing the solution according to the invention. Water will be collected in a tank, on the basis of communicating vessels at the level of the gutter system in the downpipe 5. The only interference with the existing gutter system consists in placing the solution according to the invention there, and only the semi-rigid water pipe 2 will be visible coming from the outlet of the gutter downpipe or from the inspection hole. The person skilled in the art would appreciate that the possibility of easy dismantling of the water trap is convenient for maintaining the installation clean and in good general condition. For example, the

rainwater may be dismantled in order to remove the leaves covering the gutter or dismantled for the time of winter and mounted again in spring.

#### 5 Example 2

**[0023]** Another alternative embodiment of the invention is the possibility of fixing the gutter system rainwater trap in the vertical downpipe 5 in such way that the partition 3 is made of a semi-permeable mesh. After feeding the hardening foam through the pipe supplying the sealing and fixing agent 4 to the partition 3, a bag is formed with dimensions adapted to the downpipe 5 and the overflow connector 1. After placing it in the target location in the downpipe 5, the partition 3 is filled with hardening foam, thus creating a partition 3. After the hardening foam has hardened, the gutter system rainwater trap is ready to fulfil its task of damming and directing the rainwater to the water pipe 2 and then to the water tank 6 or elsewhere at the level of the partition 3 or below. In the event of excess water, part of the water that cannot be absorbed by the water pipe 2, after reaching the level of the upper edge of the overflow stud pipe 1, is directed through the overflow stud pipe 1 to the section of the downpipe 5 below the partition 3 and then flows down as before installing of the partition 3. The person skilled in the art would appreciate that the hardening foam may be any hardening foam, for example polyurethane foam, such as one known commercially, of Soudal company or other..

**[0024]** The advantage of using the invention is that by trapping and collecting rainwater, this water can be used both during rainfall and after the rainfall has stopped, at any time, by using the accumulated water from the water tank 6.

**[0025]** Water accumulated at a height of several or a dozen meters above the ground can be used without an additional pump, by gravity flow, for watering, for example, a home garden. The trap according to the invention will catch any, even small amounts of water, because a tight partition 3 of the downpipe 5 is used.

**[0026]** Simultaneously with the collection of water, in the event of very heavy rain, the excess water will be directed through the overflow stub pipe 1 to the section of the downpipe 5 below the solution according to the invention, without neglecting the intake of "normal water".

**[0027]** List of symbols:

- 50 1 - overflow stub pipe
- 2 - water pipe
- 3 - partition
- 4 - pipe for supplying the sealing and fixing agent
- 5 - downpipe
- 55 6 - water tank

## Claims

1. Gutter system rainwater trap, comprising an overflow stub pipe (1), the stub pipe (1) having a solid outer or side wall and being open at its top, inside which a generally vertical water pipe (2) is placed, the inlet end of the water pipe (2) passing through an opening in the outer (side) wall, and to the outer (side) wall of the overflow stub pipe (1) there is attached a partition (3) and a pipe (4) for supplying a sealing and fixing agent to the partition (3). 5
2. The gutter system rainwater trap according to claim 1, **characterized in that** the partition (3) is a semi-permeable mesh filled with a sealing and fixing agent. 15
3. The rainwater trap according to claim 1, **characterized in that** the partition (3) is a rubber torus-tube filled with a sealing and fixing agent. 20
4. The rainwater trap according to claim 2, **characterized in that** the sealing and fixing agent introduced into the partition (3) by means of the pipe (4) for supplying the sealing and fixing agent is any hardening foam. 25
5. The rainwater trap according to claim 4, **characterized in that** the sealing and fixing agent is a polyurethane foam. 30
6. The rainwater trap according to claim 1, 2 or 3, **characterized in that** the sealing and fixing agent introduced into the partition (3) by means of the pipe (4) for supplying the sealing and fixing agent is any agent enabling filling the partition (3) up to a given pressure. 35
7. The rainwater trap according to claim 6, **characterized in that** the sealing and mounting agent is any gas unaggressive to rainwater trap materials, for example air, nitrogen, carbon dioxide, argon. 40
8. The rainwater trap according to claim 6, **characterized in that** the sealing and mounting agent is any liquid unaggressive to rainwater trap materials, for example water. 45
9. The rainwater trap according to any preceding claim, **characterized in that** the partition (3) fixes the rainwater trap in the gutter system after the sealing and fixing agent has been introduced by means of the pipe (4) for supplying the sealing and fixing agent after reaching the planned location in the downpipe. 50
10. The rainwater trap according to any of claims 1-3, 6-9, **characterized in that** the gutter system rainwater trap is installed permanently or detachably. 55

11. The rainwater trap according to any preceding claim, **characterized in that** the overflow pipe (1), the water pipe (2), the partition (3) and the pipe (4) for supplying the sealing-fixing agent to the partition (3) are integrated in such way that they constitute one monolith.

## Patentansprüche

1. Ein Rinnensystem-Regenwasserfänger mit einem Überlaufstutzen (1), wobei der Überlaufstutzen (1) eine feste äußere oder seitliche Wand aufweist und an seiner Oberseite offen ist, in dem eine im Allgemeinen vertikale Wasserleitung (2) angeordnet ist, wobei das Einlassende der Wasserleitung (2) durch eine Öffnung in der äußeren (seitlichen) Wand hindurchgeht, und an der äußeren (seitlichen) Wand des Überlaufstutzens (1) eine Trennwand (3) und eine Leitung (4) für die Zuführung eines Dicht- und Befestigungsstoffs für die Trennwand (3) befestigt ist.
2. Rinnensystem-Regenwasserfänger nach Anspruch 1, **dadurch gekennzeichnet, dass** die Trennwand (3) ein halbdurchlässiges Netz ist, das mit einem Dicht- und Befestigungsstoff gefüllt ist.
3. Regenwasserfänger nach Anspruch 1, **dadurch gekennzeichnet, dass** die Trennwand (3) ein mit dem Dicht- und Befestigungsstoff gefüllter torusförmiger Schlauch aus Gummi ist.
4. Regenwasserfänger nach Anspruch 2, **dadurch gekennzeichnet, dass** der in die Trennwand (3) über die Leitung (4) für die Zuführung des Dicht- und Befestigungsstoffs eingebrachte Dicht- und Befestigungsstoff ein beliebiger, aushärtender Schaum ist.
5. Regenwasserfänger nach Anspruch 4, **dadurch gekennzeichnet, dass** der Dicht- und Befestigungsstoff ein Polyurethanschaum ist.
6. Regenwasserfänger nach Ansprüchen 1, 2 oder 3, **dadurch gekennzeichnet, dass** der in die Trennwand (3) über die Leitung (4) für die Zuführung des Dicht- und Befestigungsstoffs eingebrachte Dicht- und Befestigungsstoff ein beliebiger Stoff ist, der die Befüllung der Trennwand (3) bis zum vorgegebenen Druck ermöglicht.
7. Regenwasserfänger nach Anspruch 6, **dadurch gekennzeichnet, dass** der Dicht- und Befestigungsstoff ein beliebiges, für das Regenwasserfänger-Material nicht aggressives Gas ist, z. B. Luft, Stickstoff, Kohlendioxid, Argon.
8. Regenwasserfänger nach Anspruch 6, **dadurch ge-**

**kennzeichnet, dass** der Dicht- und Befestigungsstoff eine beliebige, für das Regenwasserfänger-Material nicht aggressive Flüssigkeit ist, z. B. Wasser.

9. Regenwasserfänger nach einem der vorhergehenden Ansprüche, **dadurch gekennzeichnet, dass** die Trennwand (3) den Regenwasserfänger im Rinnensystem fixiert, nachdem der Dicht- und Befestigungsstoff über die Leitung (4) für die Zuführung des Dicht- und Befestigungsstoffs nach dem Erreichen der Soll-Stelle im Fallrohr eingebracht wurde. 5
10. Regenwasserfänger nach einem der Ansprüche 1-3, 6-9, **dadurch gekennzeichnet, dass** der Regenwasserfänger im Rinnensystem fest oder demontierbar befestigt ist. 10
11. Regenwasserfänger nach einem der vorhergehenden Ansprüche, **dadurch gekennzeichnet, dass** der Überlaufstutzen (1), die Wasserleitung (2), die Trennwand (3) und die Leitung (4) für die Zuführung des Dichtstoffs zur Trennwand (3) so integriert sind, dass sie einen monolithischen Körper bilden. 20

#### Revendications

1. Collecteur d'eau de pluie pour système de gouttière, comprenant un tuyau de trop-plein, 30
 

le tuyau de trop-plein (1) ayant une paroi extérieure ou latérale solide et étant ouvert à son sommet, dans lequel un tuyau d'eau (2) généralement vertical est placé, l'extrémité d'entrée du tuyau d'eau (2) passant par une ouverture dans la paroi extérieure (latérale), et une cloison (3) et un tuyau (4) étant attachés à la paroi extérieure (latérale) du tuyau de trop-plein (1) pour fournir un agent d'étanchéité et de fixation à la cloison (3). 35
2. Le collecteur d'eau de pluie du système de gouttière selon la revendication 1, **caractérisé en ce que** la cloison (3) est un filet semi-perméable rempli d'un agent de d'étanchéité et de fixation. 40
3. Le collecteur d'eau de pluie selon la revendication 1, **caractérisé en ce que** la cloison (3) est un tube torique en caoutchouc rempli d'un agent d'étanchéité et de fixation. 45
4. Le collecteur d'eau de pluie selon la revendication 2, **caractérisée en ce que** l'agent d'étanchéité et de fixation introduit dans la cloison (3) au moyen du tuyau (4) d'alimentation en agent d'étanchéité et de fixation est une mousse durcissante quelconque. 50
5. Le collecteur d'eau de pluie selon la revendication

4, **caractérisée en ce que** l'agent d'étanchéité et de fixation est une mousse de polyuréthane.

6. Le collecteur d'eau de pluie selon la revendication 1, 2 ou 3, **caractérisée en ce que** l'agent d'étanchéité et de fixation introduit dans la cloison (3) au moyen du tuyau (4) d'alimentation en agent d'étanchéité et de fixation est tout agent permettant de remplir la cloison (3) jusqu'à une pression donnée. 55
7. Le collecteur d'eau de pluie selon la revendication 6, **caractérisée en ce que** l'agent d'étanchéité et de fixation est un gaz quelconque non agressif pour les matériaux du collecteur d'eau de pluie, par exemple l'air, l'azote, le dioxyde de carbone, l'argon. 60
8. Le collecteur d'eau de pluie selon la revendication 6, **caractérisée en ce que** l'agent de d'étanchéité et de fixation est un liquide quelconque non agressif pour les matériaux du collecteur d'eau de pluie, par exemple l'eau. 65
9. Le collecteur d'eau de pluie selon toute revendication précédente, **caractérisée en ce que** la cloison (3) fixe le collecteur d'eau de pluie dans le système de gouttière après que l'agent d'étanchéité et de fixation a été introduit au moyen du tuyau (4) d'alimentation en agent d'étanchéité et de fixation après avoir atteint l'emplacement prévu dans le tuyau de descente. 70
10. Le collecteur d'eau de pluie selon l'une des revendications 1 à 3, 6 à 9, **caractérisé en ce que** le collecteur d'eau de pluie du système de gouttière est installé de manière permanente ou amovible. 75
11. Le collecteur d'eau de pluie selon toute revendication précédente, **caractérisée en ce que** le tuyau de trop-plein (1), le tuyau d'eau (2), la cloison (3) et le tuyau (4) d'alimentation en agent d'étanchéité et de fixation au cloison (3) sont intégrés de telle sorte qu'ils constituent un monolithe. 80

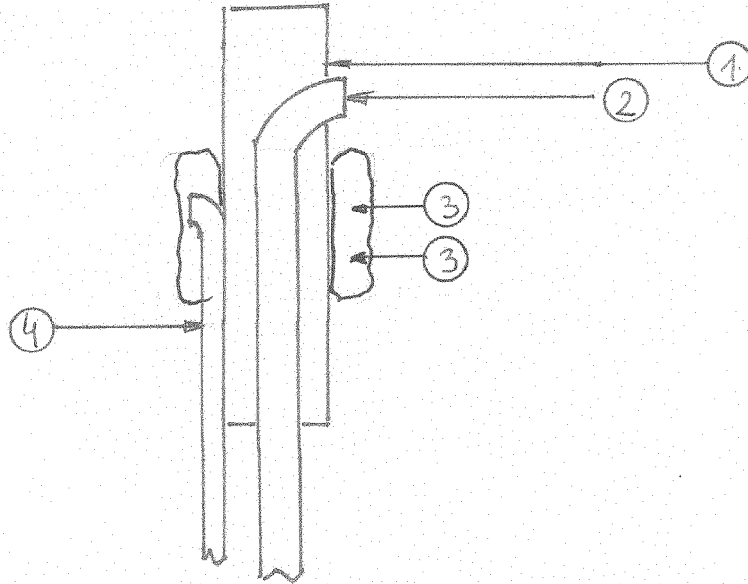

Fig. 1

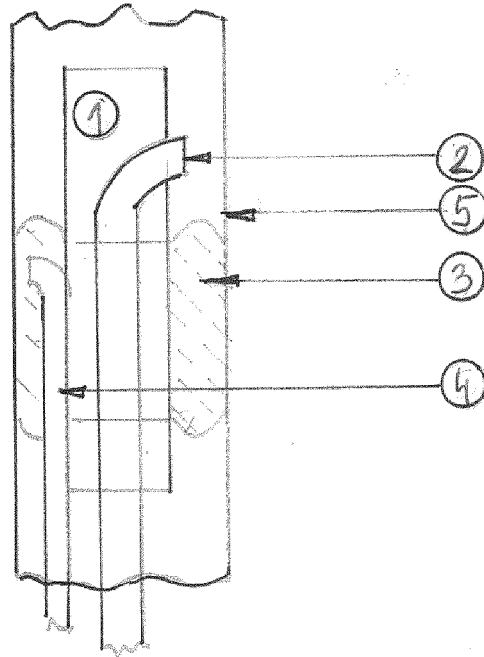

Fig. 2

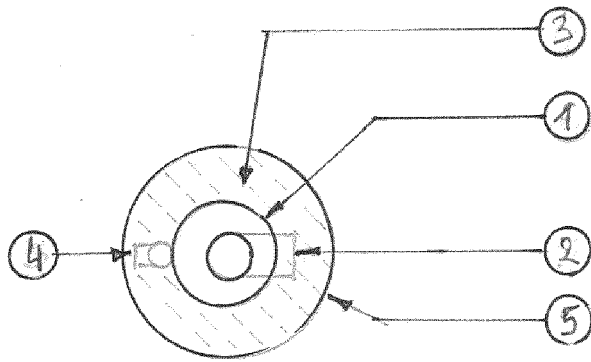

Fig. 3

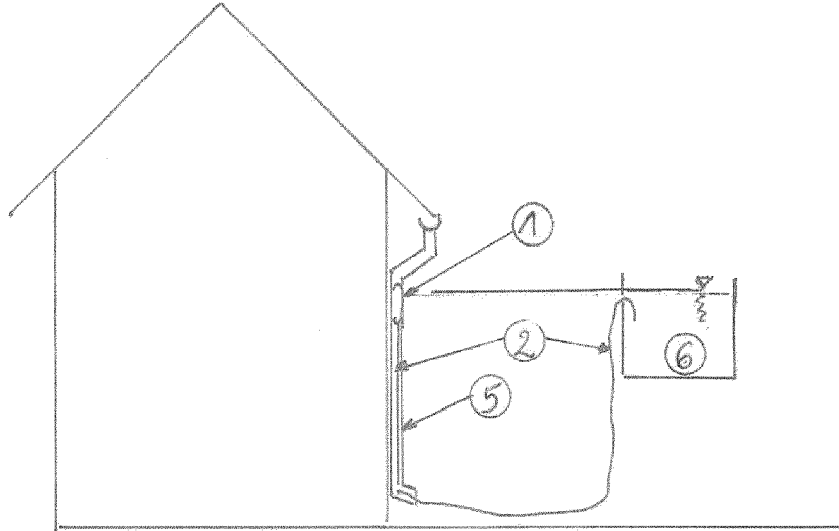

Fig. 4

**REFERENCES CITED IN THE DESCRIPTION**

*This list of references cited by the applicant is for the reader's convenience only. It does not form part of the European patent document. Even though great care has been taken in compiling the references, errors or omissions cannot be excluded and the EPO disclaims all liability in this regard.*

**Patent documents cited in the description**

- US 2013248016 A1 [0003]