



- (51) International Patent Classification: **D06F 47/00** (2006.01)
- (21) International Application Number: PCT/US2012/047219
- (22) International Filing Date: 18 July 2012 (18.07.2012)
- (25) Filing Language: English
- (26) Publication Language: English
- (30) Priority Data: 61/511,791 26 July 2011 (26.07.2011) US
- (71) Applicant (for all designated States except US): **PELLERIN MILNOR CORPORATION** [US/US]; 700 Jackson Street, Kenner, Louisiana 70063 (US).
- (72) Inventors; and
- (75) Inventors/Applicants (for US only): **POY, Russell, H.** [US/US]; 601 Baronne Street, Number 3B, New Orleans, Louisiana 70113 (US). **KULAKOWSKI, Chris** [US/US]; 5467 Marcia Avenue, New Orleans, Louisiana 70124 (US).
- (74) Agents: **D'SOUZA, Vanessa, M.** et al.; Garvey, Smith, Nehrbaas & North, L.L.C., 3838 N. Causeway Blvd., Suite 3290, Metairie, Louisiana 70002 (US).
- (81) Designated States (unless otherwise indicated, for every kind of national protection available): AE, AG, AL, AM, AO, AT, AU, AZ, BA, BB, BG, BH, BR, BW, BY, BZ, CA, CH, CL, CN, CO, CR, CU, CZ, DE, DK, DM, DO, DZ, EC, EE, EG, ES, FI, GB, GD, GE, GH, GM, GT, HN, HR, HU, ID, IL, IN, IS, JP, KE, KG, KM, KN, KP, KR, KZ, LA, LC, LK, LR, LS, LT, LU, LY, MA, MD, ME, MG, MK, MN, MW, MX, MY, MZ, NA, NG, NI, NO, NZ, OM, PE, PG, PH, PL, PT, QA, RO, RS, RU, RW, SC, SD, SE, SG, SK, SL, SM, ST, SV, SY, TH, TJ, TM, TN, TR, TT, TZ, UA, UG, US, UZ, VC, VN, ZA, ZM, ZW.
- (84) Designated States (unless otherwise indicated, for every kind of regional protection available): ARIPO (BW, GH, GM, KE, LR, LS, MW, MZ, NA, RW, SD, SL, SZ, TZ, UG, ZM, ZW), Eurasian (AM, AZ, BY, KG, KZ, RU, TJ, TM), European (AL, AT, BE, BG, CH, CY, CZ, DE, DK, EE, ES, FI, FR, GB, GR, HR, HU, IE, IS, IT, LT, LU, LV, MC, MK, MT, NL, NO, PL, PT, RO, RS, SE, SI, SK, SM, TR), OAPI (BF, BJ, CF, CG, CI, CM, GA, GN, GQ, GW, ML, MR, NE, SN, TD, TG).

[Continued on next page]

(54) Title: LAUNDRY PRESS APPARATUS AND METHOD

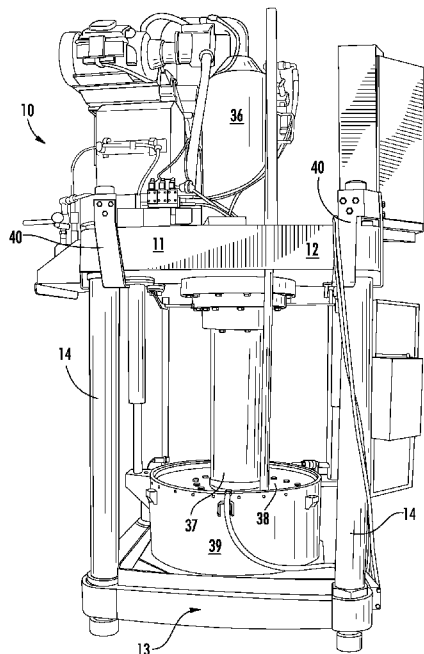

FIG. 8

(57) Abstract: A press for pressing batches of fabric articles to remove excess fluid therefrom utilizes a specially configured frame having upper and lower plates. The frame supports a vessel having an interior that is configured to receive a batch of fabric articles therein. A press having a ram and a disk is supported at the lower end portion of the ram. The disk is positioned to engage an upper surface portion of the batch of articles that are contained within the vessel interior. The ram and disk are movable between upper and lower positions, the lower position being a pressing position that engages the disk with the fabric articles. The frame includes a plurality of rods that connect to the upper and lower plates, spacing the upper and lower plates apart. The rods each have upper and lower end portions, each with a diameter that is larger than the diameter of a central portion of said rod that is positioned in between the upper and lower plates. The central portion is spaced away from each of the plates.

WO 2013/016103 A1



Published:

— with international search report (Art. 21(3))

— before the expiration of the time limit for amending the claims and to be republished in the event of receipt of amendments (Rule 48.2(h))

PATENT APPLICATION

Attorney Docket No. A11128US (98552.23)

PCT Attorney Docket No. A11128WO (98552.23WO)

TITLE OF THE INVENTION

5 LAUNDRY PRESS APPARATUS AND METHOD

INVENTOR: POY, Russell, H., a US citizen, of 601 Baronne Street, Number 3B, New Orleans, LA, 70113, US; and KULAKOWSKI, Chris, a US citizen, of 5467 Marcia Avenue, New Orleans, LA, 70124, US.

ASSIGNEE: PELLERIN MILNOR CORPORATION, a Louisiana corporation, of 700 Jackson Street, P.O. Box 400, Kenner, Louisiana 70063, US.

CROSS-REFERENCE TO RELATED APPLICATIONS

In the US, this is a non-provisional application of US Provisional Patent Application Serial No. 61/511,791 filed 26 July 2011.

Priority of US Provisional Application Serial No. 61/511,791, filed 26 July 2011, incorporated herein by reference, is hereby claimed.

STATEMENT REGARDING FEDERALLY SPONSORED RESEARCH OR DEVELOPMENT

Not applicable

REFERENCE TO A "MICROFICHE APPENDIX"

20 Not applicable

BACKGROUND OF THE INVENTION

1. Field of the Invention

The present invention relates to an improved apparatus for pressing fluid (e.g., rinse water) from fabric articles (e.g., laundry). More particularly, the present invention relates to a method and apparatus for pressing fluid from laundry articles wherein the press frame has a specially configured tie rod arrangement with improved fatigue performance.

2. General Background of the Invention

Laundry presses remove water from washed linen by hydraulically applying pressure. This force is developed by pressurizing a hydraulic ram pressing down on linen held in a pressure vessel. The water is pushed out of the linen into a slotted or apertured plate under the linen. The following patents (each incorporated herein by reference)

relate generally to laundry presses and like devices.

TABLE

	<u>PATENT NO.</u>	<u>TITLE</u>	<u>ISSUE DATE</u> MM-DD-YYYY
5	1,359,745	Ironing Machine	11-23-1920
	1,893,190	Ironing Machine	01-03-1933
	2,142,202	Ironing and Pressing Machine	01-03-1939
	2,531,890	Indexing and Lock Mechanism	11-28-1950
	RE 24,257	Combined Washing and Squeeze Drying Machine	12-18-1956
10	3,071,878	Ironing Machine	01-08-1963
	3,908,413	Pressing Apparatus for the Pressure Extracting of Liquid	09-30-1975
	3,924,425	Presses for Washing	12-09-1975
	4,180,995	Pressing Apparatus for Squeezing Laundry and the Like	01-01-1980
	4,452,056	Liquid Extracting Apparatus	06-05-1984
15	4,471,637	Apparatus for Dewatering Items of Washed Laundry	09-18-1984
	4,525,935	Method for Dewatering Items of Washed Laundry	07-02-1985
	4,574,599	Apparatus for Pressing Liquid from Cloth Goods	03-11-1986
	4,676,079	Appliance for Draining Washed Laundry Articles	06-30-1987
	4,753,089	Water-Removal Press for Textiles	06-28-1988
20	5,001,911	Ram Press for Expressing Liquid from Materials Being Pressed	03-26-1991
	5,065,535	Indexing System for Rotary Garment Press	11-19-1991
	5,331,755	Ironing Press with Horizontally Rotatable Pressing Members	07-26-1994

5,970,637	Automatic Shirt Pressing Apparatus Including a Vacuum System and Associated Method	10-26-1999
-----------	--	------------

The primary structure of a laundry press frame provides a bottom and top plate held together with four posts or rods.

The prior art solid posts or rods are machined to create a top and bottom shoulder and then threaded on both ends. A fastening nut is then applied on the top and bottom.

The life of these posts are known to be compromised because the posts endure a significant amount of bending along with normal loss of preload tension due to wear.

BRIEF SUMMARY OF THE INVENTION

The present invention increases the fatigue life for a laundry press by a factor of 200% to 300%. The design of the present invention includes a spool and specially configured full length tie rod.

In one embodiment, a fastening nut has been designed to have an outer slot in its body. This slot distributes the loading in the nut threads evenly across all threads wherein previous designs the loading is only on the first 1 to 3 threads.

The full length tie rod increases the fatigue by applying a reduced shank profile. The reduced shank allows the tie rod under tension and bending loading to stretch freely in the center instead of stretching where the fastening nut holds the threads of the post.

The present invention provides a press for pressing batches of fabric articles to remove excess fluid therefrom. The apparatus includes a frame having upper and lower plates.

The frame supports a vessel having an interior that is configured to receive a batch of fabric articles therein.

The frame supports a press having a ram and a disk. The disk is supported at the lower end portion of the ram.

The disk is positioned to engage an upper surface portion of the batch of fabric articles that are contained within the vessel interior.

The ram and disk are movable between upper and lower positions, the lower position being a pressing position that engages the disk with the fabric articles.

The frame includes a plurality of rods that connect to the upper and lower plates, spacing the upper and lower plates apart. The rods each have upper and lower end

portions, each with a diameter that is larger than the diameter of a central portion of the rod that is positioned in between the upper and lower plates. The central portion is spaced away from each of the plates.

5 In one embodiment, each rod is attached to the upper and lower plates with a connection that includes a threaded portion of the rod and a nut that connects to the threaded portion.

In one embodiment, the nut has an annular slot.

In one embodiment, the connection includes a preload ring placed in between the nut and a plate.

10 In one embodiment, each preload ring has a concavity. The nut has a convex portion that registers in the concavity.

In one embodiment, the nut has a load bearing face, a non-load bearing face and a length in between the load bearing face and non-load bearing face. The annular slot is closer to the load bearing face than it is to the non-load bearing face. In one embodiment,
15 the annular slot is spaced from the load bearing face a distance of about 1/4 of the length.

In one embodiment, the plates have plate openings that are receptive of rod end portions.

The present invention includes a laundry press apparatus, comprising a frame having upper and lower plates and a plurality of spacer tubes that hold the plates apart,
20 each tube having a tube bore; the frame supporting a vessel, the vessel having an interior that is configured to receive a batch of wetted fabric articles; the frame supporting a press, the press including a ram and a disk supported at the lower end portion of the ram; wherein the disk is positioned to engage an upper surface portion of the batch of articles that is contained within the vessel interior; the ram and the disk being movable between
25 upper and lower positions, the lower position being a pressing position that engages the disk with the fabric articles; the frame including a plurality of rods that extend to the upper and lower plates, the rods each occupying a tube bore, each rod having upper and lower rod end portions; and fasteners that apply tension to each rod and compression to each tube.

30 Preferably, each rod includes a threaded portion and the fastener includes a nut that connects to the threaded portion.

Preferably, the nut has an annular slot.

Preferably, the fastener includes a preload ring that is placed in between the nut and a plate.

Preferably, each preload ring has a concavity and the nut has a convex portion that registers in a concavity.

5 Preferably, the nut has a load bearing face, a non-load bearing face and a length in between the load bearing face and the non-load bearing face, wherein the annular slot is closer to the load bearing face than the non-load bearing face.

Preferably, the annular slot is spaced from the load bearing face a distance of about 1/4 of the length.

10 Preferably, the plates have plate openings that are receptive of the rod end portions.

Preferably, each rod has threads that do not connect to a plate.

The present invention includes a laundry press for pressing a batch of fabric articles to remove excess fluid from the articles, comprising a frame having upper and lower plates, each plate having a plurality of plate openings; the frame supporting a vessel having a vessel bottom and side portion and an interior that is configured to contain a batch of fabric articles; a press supporting a ram having upper and lower ram end portions, the ram including a disk supported at the ram lower end portion; wherein the disk is positioned to engage the batch of articles contained within the vessel interior, 15 wherein the disk fits inside of the vessel side portion; the ram and the disk being movable between upper and lower positions, the lower position being a pressing position that engages the disk with the fabric articles; the frame including a plurality of rods that connect to the upper and lower plates at the plate openings, spacing the upper and lower plates apart, the rods each having upper and lower end portions that are at least partially 20 externally threaded, each with a diameter that is larger than the diameter of a central portion of the rod that is positioned in between the upper and lower plates; wherein the central portion is spaced away from each of the plates; and a plurality of nuts that each attach to an externally threaded portion of a rod end portion.

Preferably, each nut has an annular slot.

30 Preferably, the connection includes a preload ring placed in between the nut and a plate.

The present invention includes a laundry press apparatus, comprising a frame

having upper and lower plates; a plurality of spacer tubes that hold the plates apart, each tube having a tube bore; the frame supporting a vessel having an interior that is configured to receive a batch of wetted fabric articles therein that have been laundered; a press having an elongated ram and a disk supported at the lower end portion of the ram; 5 wherein the disk is positioned to engage an upper surface portion of the batch of fabric articles that are contained within the vessel interior; the ram and the disk being movable between upper and lower positions, the lower position being a pressing position that engages the disk with the fabric articles; the frame including a plurality of rods that extend to the upper and lower plates, each of the rods occupying a tube bore, each rod 10 having upper and lower rod end portions; and fasteners that apply tension to each rod and wherein each tube is in compression when each rod is tensioned.

Preferably, each rod includes a threaded end portion and each fastener includes a nut that connects to a threaded end portion.

Preferably, the fastener includes a preload ring that is positioned in between a nut 15 and a plate.

The present invention includes a press for pressing batches of fabric articles to remove excess fluid therefrom, comprising: a frame having upper and lower plates, each plate having a plurality of plate openings; the frame supporting a vessel having an interior that is configured to receive a batch of fabric articles therein; a press having a ram and 20 a disk supported at the lower end portion of the ram; wherein the disk is positioned to engage an upper surface portion of the batch of articles that are contained within the vessel interior; the ram and the disk being movable between upper and lower positions, the lower position being a pressing position that engages the disk with the fabric articles, compressing the fabric articles in between the disk and the vessel; the frame including 25 a plurality of rods that connect to the upper and lower plates at the plate openings, spacing the upper and lower plates apart, the rods each having upper and lower end portions that are at least partially externally threaded, each with a diameter that is larger than the diameter of a central portion of the rod that is positioned in between the upper and lower plates; wherein the central portion is spaced away from each of the plates; and 30 a plurality of nuts that each attach to an externally threaded portion of a rod end portion.

Preferably, each nut has an annular groove.

Preferably, the connection includes a ring that is placed in between the nut and

a plate.

Preferably, each ring has a concavity and the nut has a convex portion that registers in a concavity.

5 Preferably, the nut has a load bearing face, a non-load bearing face and a length in between the load bearing face and the non-load bearing face, wherein the annular groove is closer to the load bearing face than the non-load bearing face.

Preferably, the annular groove is spaced from the load bearing face a distance of about 1/4 of the length.

BRIEF DESCRIPTION OF THE SEVERAL VIEWS OF THE DRAWINGS

10 For a further understanding of the nature, objects, and advantages of the present invention, reference should be had to the following detailed description, read in conjunction with the following drawings, wherein like reference numerals denote like elements and wherein:

15 Figures 1A-1B are a partial top view and a side view of a preferred embodiment of the apparatus of the present invention;

Figure 2 is a partial sectional elevation view of a preferred embodiment of the apparatus of the present invention showing the press in an upper position;

Figure 3 is a partial perspective view of a preferred embodiment of the apparatus of the present invention showing the rod portion;

20 Figure 4 is a partial perspective exploded view of a preferred embodiment of the apparatus of the present invention;

Figure 5 is a partial sectional view of a preferred embodiment of the apparatus of the present invention showing a modified upper joint;

25 Figure 6 is a partial sectional view of a preferred embodiment of the apparatus of the present invention showing a modified lower joint;

Figure 7 is a partial sectional view of a preferred embodiment of the apparatus of the present invention showing a close up of the nut;

Figure 8 is a perspective view of a preferred embodiment of the apparatus of the present invention;

30 Figure 9 is a partial perspective view of a preferred embodiment of the apparatus of the present invention;

Figure 10 is a partial perspective view of a preferred embodiment of the apparatus

of the present invention;

Figure 11 is a partial perspective view of a preferred embodiment of the apparatus of the present invention;

Figure 12 is a partial perspective view of a preferred embodiment of the apparatus
5 of the present invention;

Figure 13 is a partial perspective view of a preferred embodiment of the apparatus of the present invention; and

Figure 14 is a perspective view of a preferred embodiment of the apparatus of the present invention.

10 DETAILED DESCRIPTION OF THE INVENTION

Figures 1-14 show a preferred embodiment of the apparatus of the present invention, designated generally by the numeral 10 in figures 8 and 14. The present invention provides a press 10 for pressing batches of fabric articles to remove excess fluid therefrom. In figures 8-9, press 10 employs a pressure cylinder 36 (e.g., hydraulic
15 cylinder) mounted to a machine frame 11. A piston rod or push rod 37 extends downwardly from the pressure cylinder 36, supporting a ram 38 that engages the batch of fabric articles which are contained in a shell or vessel 39.

An example of a prior art apparatus that employs a pressure cylinder, frame, ram, shell and batch of fabric articles can be seen in Figures 1 and 2 of US Patent No.
20 5,001,911 ('911 patent) entitled "RAM Press for Expressing Liquid from Materials Being Pressed". It should be understood that prior art ram presses for extracting fluid from fabric articles (such as seen in the '911 patent) are commercially available.

The present invention provides an improvement to the frame 11 that supports the pressure cylinder 36, pushrod 37, ram 38, and the batch of articles 46 to be pressed with
25 water. The apparatus 10 and the improved frame 11 can be seen in Figures 1-7 in more detail.

Figures 1A-B, 2 and 8-14 illustrate the frame 11 comprised of top plate 12, bottom plate 13, multiple spacers or spools 14, each housing a reduced shank tie rod 15, and fastening nuts 22, 23 which can be slotted fastening nuts.

30 Figures 2-3 illustrate the reduce shank tie rod 15 in more detail. Generally the length of the tie rod 15 can be between about 15 and 150 inches (38 and 381 cm). The threaded section 26, 27 length on top and bottom can be 12 to 24 inches (30 and 61 cm)

with a diameter of between about 3 and 12 inches (8 and 30 cm). The reduced shank 30 is generally with a diameter of between about 2 and 10 inches (5 and 25 cm) depending on the diameter of the threaded sections 26, 27. The reduced diameter shank 30 will always have a diameter smaller than the diameter of sections 26, 27.

5 The assembly shown in Figures 1A-1B and 2 is performed by stretching the tie rod 15 approximately 1/16" to 1/2" (0.16 cm to 1.27 cm) creating the preload which withstands the force of the hydraulic pressure when removing water from the fabric articles or linen.

10 The laundry press apparatus 10 thus employs a frame 11 having a top plate or head 12 and a bottom plate 13. The bottom plate 13 can be provided with openings, slots or bores through which water can escape.

15 A vessel, shell or other container 39 for holding a batch of fabric articles rests upon the bottom plate 13. Vessel or shell 39 has interior 45 that holds or contains fabric articles 46 to be pressed of excess fluid. The top plate 12 supports a pressure cylinder such as a hydraulic cylinder 36 having a push rod 37 and a ram 38 that engages the fabric articles which are contained within shell or vessel 39. The pressure cylinder 36 could typically extend above the top plate 12. The top plate 12 provides an opening 16 through which the pushrod or piston rod 37 of the pressure cylinder 36 extends. The ram 38 would be positioned in between the plates 12, 13 (see figures 8 and 14). Each of the top 20 12 and bottom 13 plates provides four corners, each corner having a rod 15 that is attached to both a top plate 12 and bottom plate 13.

25 Figures 2-4 show more particularly the construction of rod 15 and a spacer or spool 14 that extends around each rod 15 as shown. In Figures 2 and 4, a corner 17 is shown for each connection between a rod 15 and top plate 12. Figures 2 and 4 also show a connection between a corner 20 of a bottom plate 13. Corner 17 of top plate 12 provides a corner opening 18. Corner 20 of bottom plate 13 provides an opening 21.

Each rod 15 has a rod upper end 24 and a rod lower end 25. The rod upper end 24 provides a larger diameter threaded section 26. The rod lower end 25 provides a larger diameter threaded section 27.

30 Each rod 15 has a reduced diameter section 30. A tapered or transition section 28, 29 is provided in between the rod reduced diameter section 30 and a larger diameter threaded section 26 or 27. In Figures 2-4, tapered or transitioned section 28 is a tapered

section or transition between reduced diameter section 30 and larger diameter threaded section 26. Similarly, a tapered or transition section 29 is provided in between reduced diameter section 30 and larger diameter threaded section 27.

5 An upper nut 22 forms a threaded connection with the larger diameter threaded section 26. Similarly, nut 23 forms a threaded connection with larger diameter threaded section 27. Washer 19 is placed in between top plate 12 and nut 22. Similarly, a washer 19 is placed in between nut 23 and bottom plate 13. Spacer or spool 14 surrounds rod 15 as shown in figures 1B-4. A washer 19 can be placed in between spacer or spool 14 and top plate 12. Similarly, a washer 19 can be placed in between spacer or spool 14 and
10 bottom plate 13 (See figures 2 and 4). Figure 2 shows that the tapered or transition section 28 extends below the connection between nut 22 and top plate 12. Similarly, the transition or tapered section 29 extends above the connection of nut 23 to bottom plate 13.

Figure 5 shows a modified upper joint wherein a tension nut 31 nests in a
15 modified annular member or preload ring 32 which rests against the upper surface of upper plate 12. Nut 31 would be internally threaded to connect with external threads on an end portion of rod 15. A similar connection could be provided in between lower plate 13 and rod 15 as shown in Figure 6.

Figure 7 shows a close up view of nut 22 which has a loading face 33 and an
20 opposing face 34. In figure 7, annular groove 35 is closer to the loading face 33 when compared to the opposing face 34 as shown. The groove 35 could be about 1/4 of the distance between the loading face 33 and the opposing face 34, being closer to the loading face 33 as shown in Figure 7. Nut 23 could be constructed the same as nut 22 of figure 7. Nuts 22, 23 can have outer flats (e.g., hexagonal shape) so that the nuts can be
25 rotated with a wrench or power tool. Nut 22 (or 23) can have openings 47 that are receptive of a tool that could rotate the nut 22 or 23 (See Figure 13).

Figures 8 and 10-11 show retainer 40 which can be used to retain parts of any rod
15 that has failed (e.g., broken into pieces) during use. The retainer 40 includes a fitting 42 having internal threads that mate with the external threads 26 of a rod 15. Fitting 42 is placed above nut 22 and threadably attached to threaded section 26. A pair of flanges
30 41 are attached to fitting 42 using bolted connections 43. The flanges 41 have horizontally extending portions 44 that extend under top plate 12 as seen in figure 10.

	35	annular groove
	36	hydraulic cylinder
	37	push rod/piston rod
	38	ram
5	39	shell/vessel
	40	retainer
	41	flange
	42	fitting
	43	bolted connection
10	44	horizontally extending portion
	45	shell interior
	46	fabric articles
	47	opening

All measurements disclosed herein are at standard temperature and pressure, at
15 sea level on Earth, unless indicated otherwise. All materials used or intended to be used
in a human being are biocompatible, unless indicated otherwise.

The foregoing embodiments are presented by way of example only; the scope of
the present invention is to be limited only by the following claims.

CLAIMS

1. A laundry press apparatus, comprising:
 - a) a frame having upper and lower plates and a plurality of spacer tubes that hold the plates apart, each tube having a tube bore;
 - 5 b) the frame supporting a vessel, said vessel having an interior that is configured to receive a batch of wetted fabric articles;
 - c) the frame supporting a press, the press including a ram and a disk supported at the lower end portion of the ram;
 - d) wherein the disk is positioned to engage an upper surface portion of the
10 batch of articles that is contained within the vessel interior;
 - e) the ram and the disk being movable between upper and lower positions, the lower position being a pressing position that engages the disk with the fabric articles;
 - f) the frame including a plurality of rods that extend to the upper and lower plates, said rods each occupying a said tube bore, each rod having upper and lower rod
15 end portions; and
 - g) fasteners that apply tension to each rod and compression to each tube.
2. The press of claim 1, wherein each rod includes a threaded portion and the fastener includes a nut that connects to said threaded portion.
3. The press of claim 2, wherein the nut has an annular slot.
- 20 4. The press of claim 2, wherein the fastener includes a preload ring that is placed in between said nut and a said plate.
5. The press of claim 4 wherein each preload ring has a concavity and the nut has a convex portion that registers in a said concavity.
6. The press of claim 3, wherein the nut has a load bearing face, a non-load
25 bearing face and a length in between the load bearing face and the non-load bearing face, wherein the annular slot is closer to the load bearing face than the non-load bearing face.
7. The press of claim 6 wherein the annular slot is spaced from the load bearing face a distance of about 1/4 of said length.
8. The press of claim 1 wherein the plates have plate openings that are receptive
30 of said rod end portions.
9. The press of said claim 1 wherein each rod has threads that do not connect to a said plate.

10. A laundry press for pressing a batch of fabric articles to remove excess fluid from the articles, comprising:
- a) a frame having upper and lower plates, each plate having a plurality of plate openings;
 - 5 b) the frame supporting a vessel having a vessel bottom and side portion and an interior that is configured to contain a batch of fabric articles;
 - c) a press supporting a ram having upper and lower ram end portions, the ram including a disk supported at the ram lower end portion;
 - d) wherein the disk is positioned to engage the batch of articles contained
10 within the vessel interior, wherein the disk fits inside of the vessel side portion;
 - e) the ram and the disk being movable between upper and lower positions, the lower position being a pressing position that engages the disk with the fabric articles;
 - f) the frame including a plurality of rods that connect to the upper and lower
15 having upper and lower end portions that are at least partially externally threaded, each with a diameter that is larger than the diameter of a central portion of said rod that is positioned in between the upper and lower plates;
 - g) wherein the central portion is spaced away from each of the plates; and
 - h) a plurality of nuts that each attach to an externally threaded portion of a rod
20 end portion.
11. The press of claim 10, wherein each nut has an annular slot.
12. The press of claim 10, wherein the connection includes a preload ring placed in between said nut and a said plate.
13. The press of claim 12 wherein each preload ring has a concavity and the nut
25 has a convex portion that registers in a said concavity.
14. The press of claim 11, wherein the nut has a load bearing face, a non-load bearing face and a length in between the load bearing face and the non-load bearing face, wherein the annular slot is closer to the load bearing face than the non-load bearing face.
15. The press of claim 14 wherein the annular slot is spaced from the load
30 bearing face a distance of about 1/4 of said length.
16. A laundry press apparatus, comprising:

- a) a frame having upper and lower plates;
- b) a plurality of spacer tubes that hold the plates apart, each tube having a tube bore;
- c) the frame supporting a vessel having an interior that is configured to receive a batch of wetted fabric articles therein that have been laundered;
- 5 d) a press having an elongated ram and a disk supported at the lower end portion of the ram;
- e) wherein the disk is positioned to engage an upper surface portion of the batch of fabric articles that are contained within the vessel interior;
- 10 f) the ram and the disk being movable between upper and lower positions, the lower position being a pressing position that engages the disk with the fabric articles;
- g) the frame including a plurality of rods that extend to the upper and lower plates, each of said rods occupying a said tube bore, each rod having upper and lower rod end portions; and
- 15 h) fasteners that apply tension to each rod and wherein each tube is in compression when each rod is tensioned.
17. The press of claim 16, wherein each rod includes a threaded end portion and each fastener includes a nut that connects to a said threaded end portion.
18. The press of claim 17, wherein the nut has an annular slot.
- 20 19. The press of claim 17, wherein the fastener includes a preload ring that is positioned in between a said nut and a said plate.
20. The press of claim 19 wherein each preload ring has a concavity and the nut has a convex portion that registers in a said concavity.
21. The press of claim 18, wherein the nut has a load bearing face, a non-load bearing face and a length in between the load bearing face and the non-load bearing face, wherein the annular slot is closer to the load bearing face than the non-load bearing face.
- 25 22. The press of claim 21 wherein the annular slot is spaced from the load bearing face a distance of about 1/4 of said length.
23. The press of claim 16 wherein the plates have plate openings that are receptive of said rod end portions.
- 30 24. The press of said claim 16 wherein each rod has threads that do not

connect to a said plate.

25. A press for pressing batches of fabric articles to remove excess fluid therefrom, comprising:

- 5 a) a frame having upper and lower plates, each plate having a plurality of plate openings;
- b) the frame supporting a vessel having an interior that is configured to receive a batch of fabric articles therein;
- c) a press having a ram and a disk supported at the lower end portion of the ram;
- 10 d) wherein the disk is positioned to engage an upper surface portion of a said batch of articles that are contained within the vessel interior;
- e) the ram and the disk being movable between upper and lower positions, the lower position being a pressing position that engages the disk with the fabric articles, compressing the fabric articles in between the disk and the vessel;
- 15 f) the frame including a plurality of rods that connect to the upper and lower plates at said plate openings, spacing the upper and lower plates apart, said rods each having upper and lower end portions that are at least partially externally threaded, each with a diameter that is larger than the diameter of a central portion of said rod that is positioned in between the upper and lower plates;
- 20 g) wherein the central portion is spaced away from each of the plates; and
- h) a plurality of nuts that each attach to an externally threaded portion of a rod end portion.

26. The press of claim 25, wherein each nut has an annular groove.

27. The press of claim 25, wherein the connection includes a ring that is placed
25 in between a said nut and a said plate.

28. The press of claim 27 wherein each ring has a concavity and the nut has a convex portion that registers in a said concavity.

29. The press of claim 26, wherein the nut has a load bearing face, a non-load bearing face and a length in between the load bearing face and the non-load bearing face,
30 wherein the annular groove is closer to the load bearing face than the non-load bearing face.

30. The press of claim 29 wherein the annular groove is spaced from the load bearing face a distance of about $1/4$ of said length.

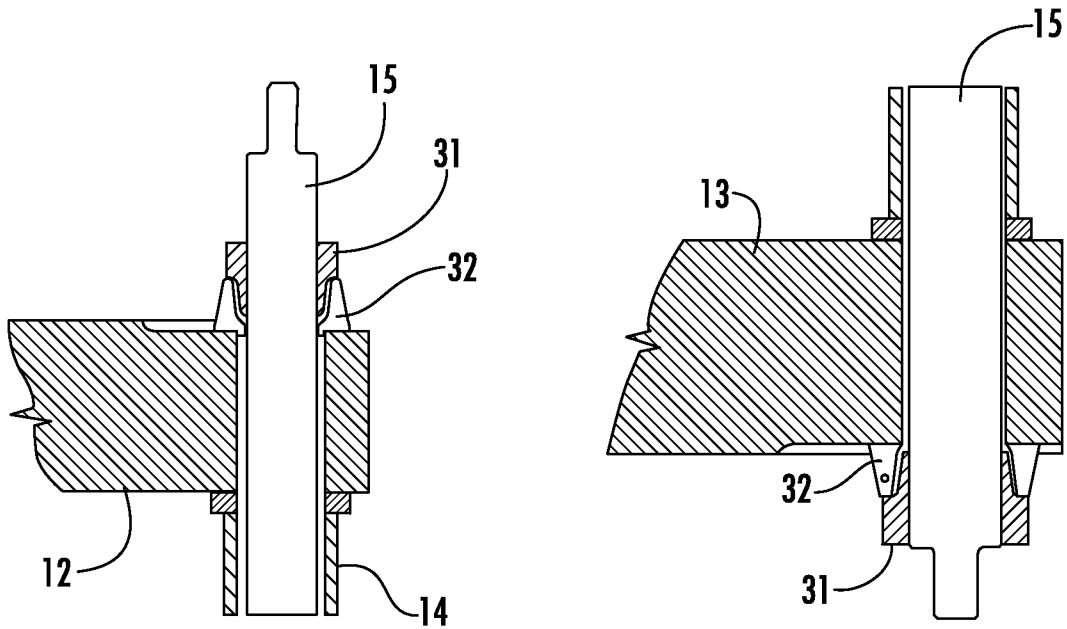

FIG. 5

FIG. 6

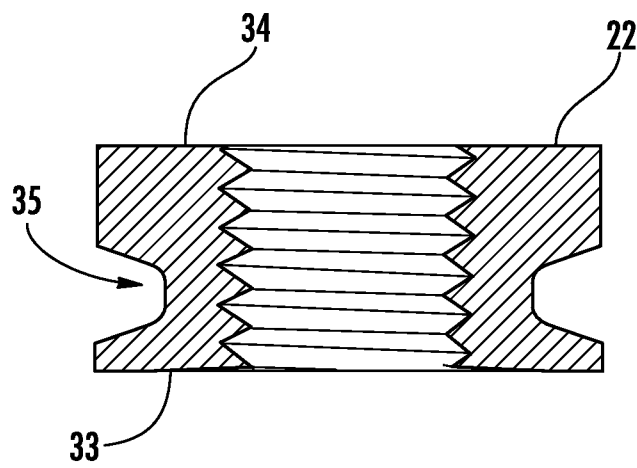

FIG. 7

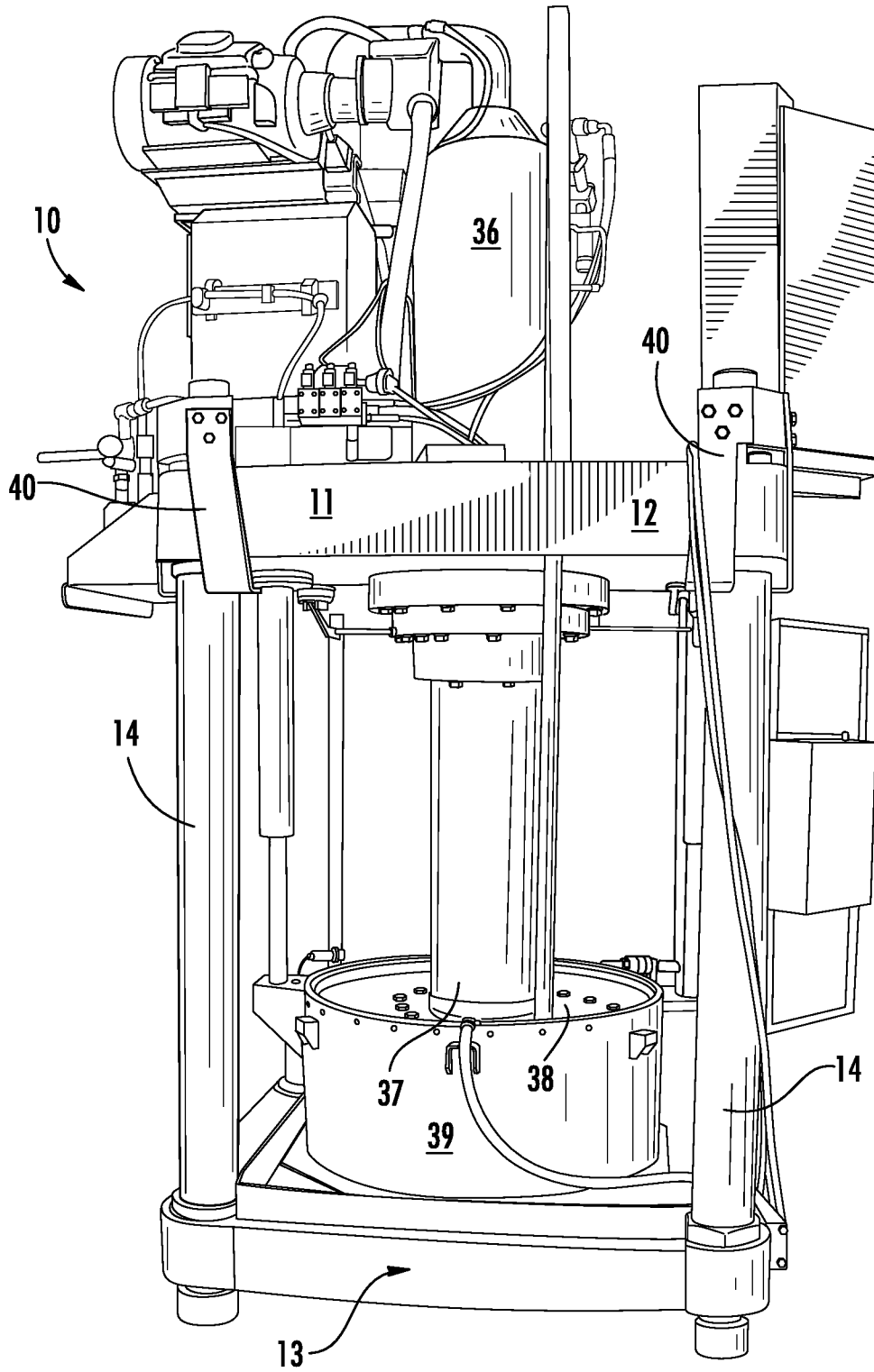

FIG. 8

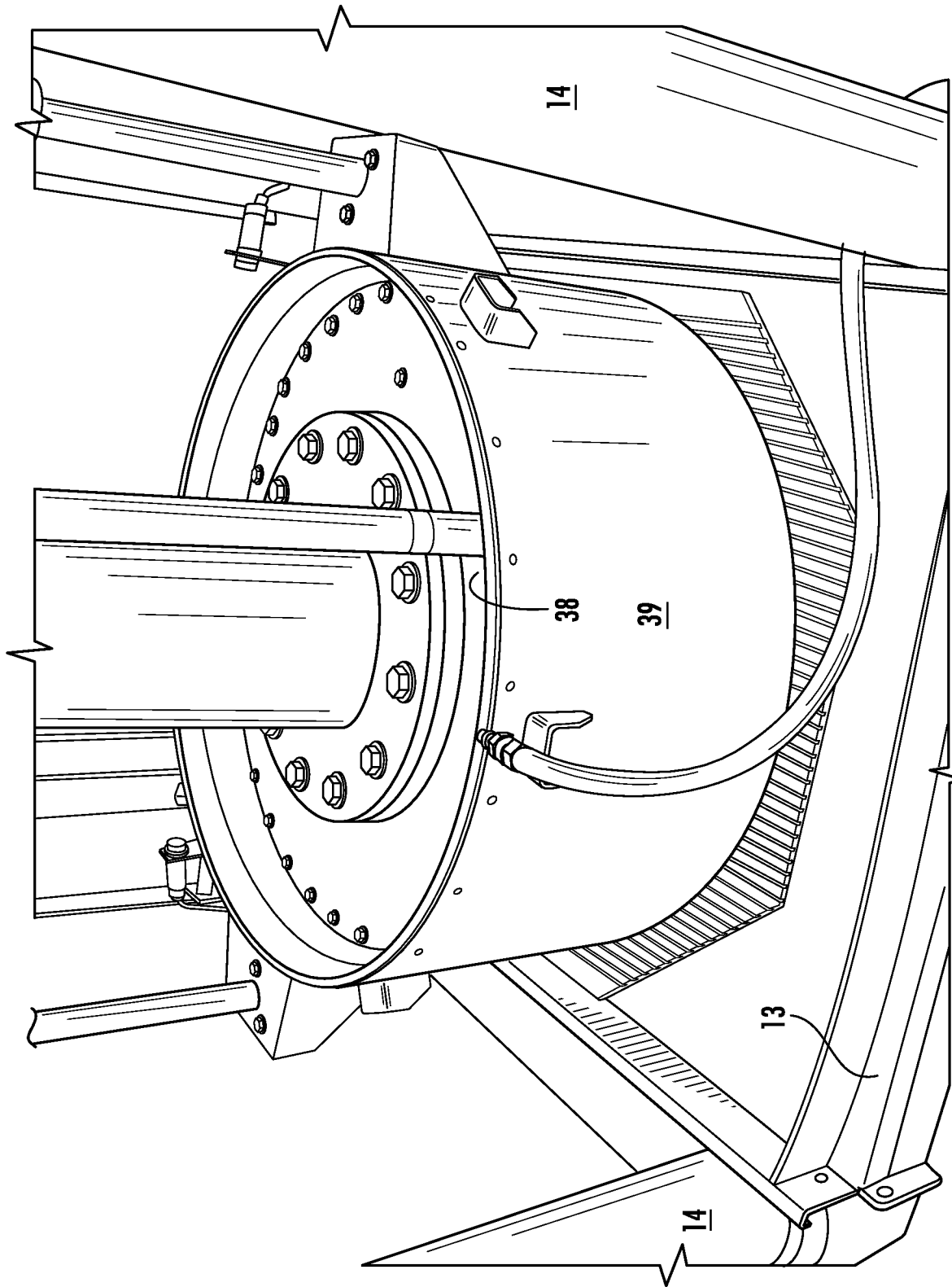

FIG. 9

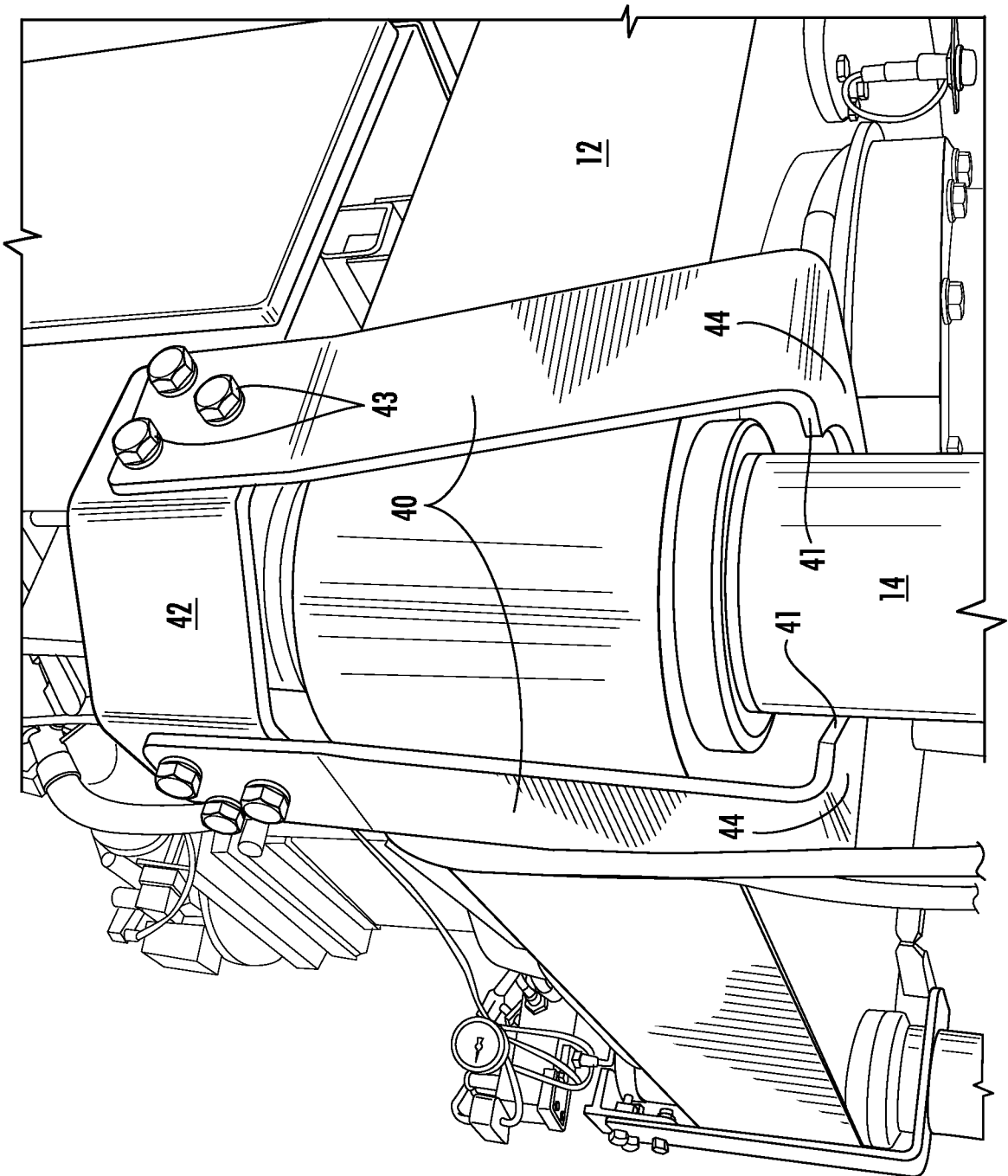

FIG. 10

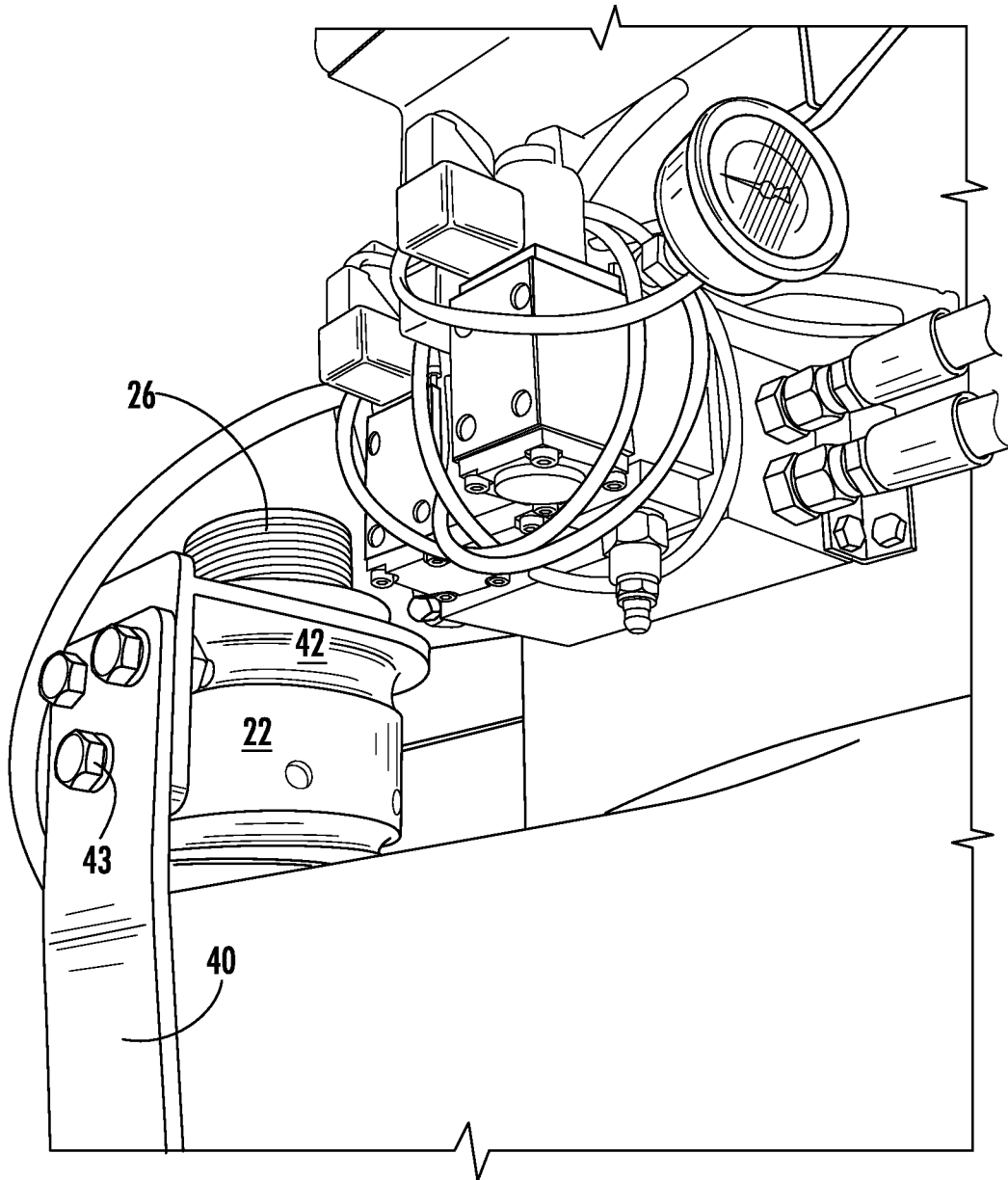

FIG. 11

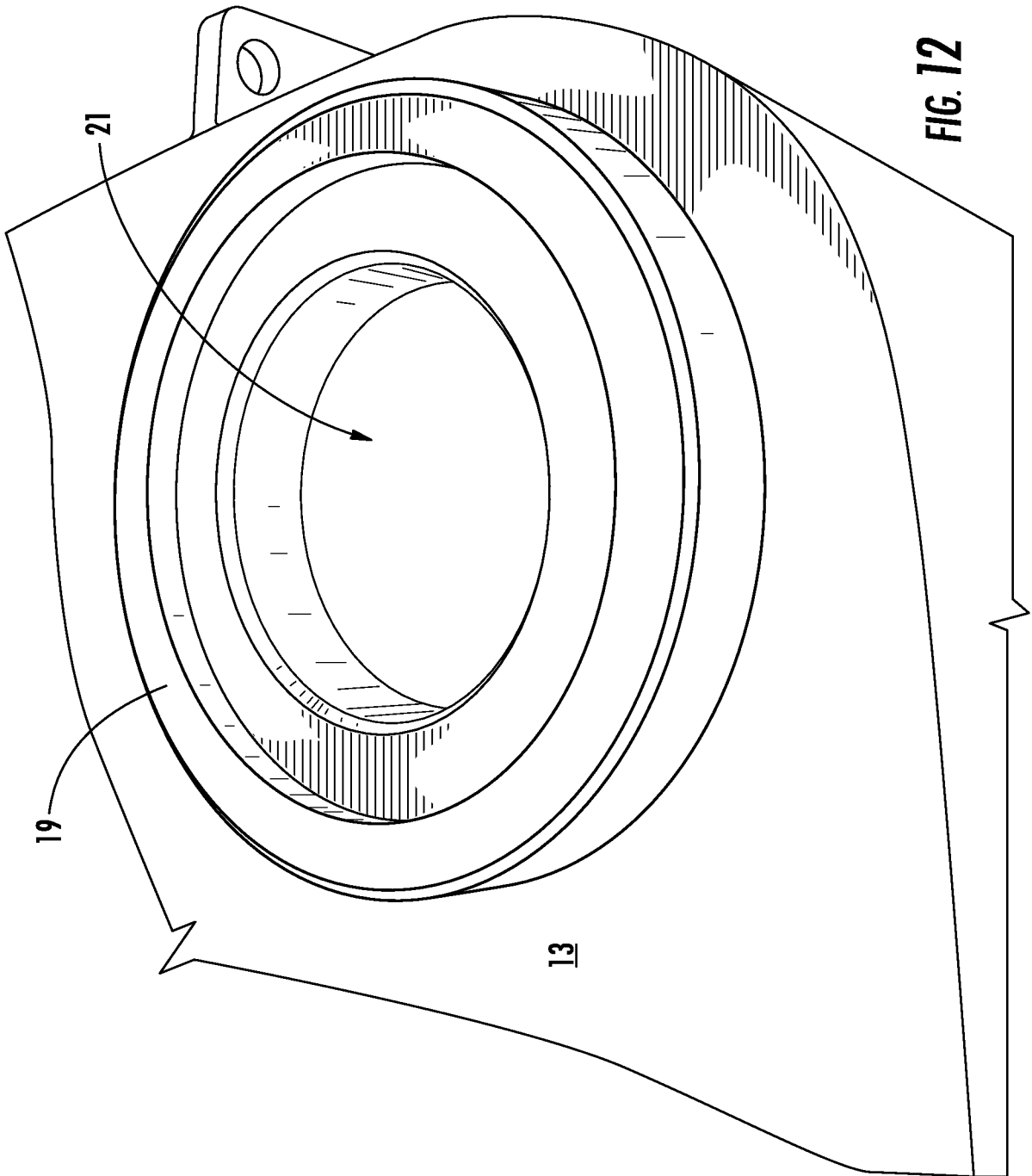

FIG. 12

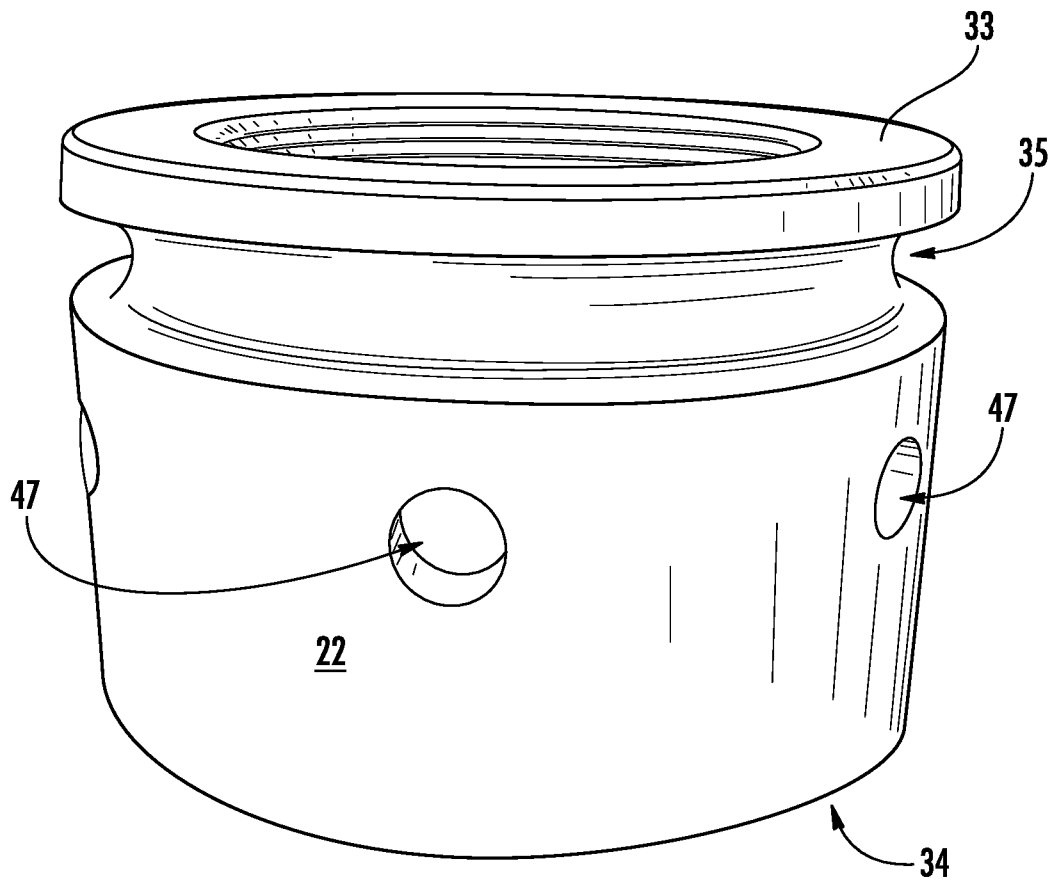

FIG. 13

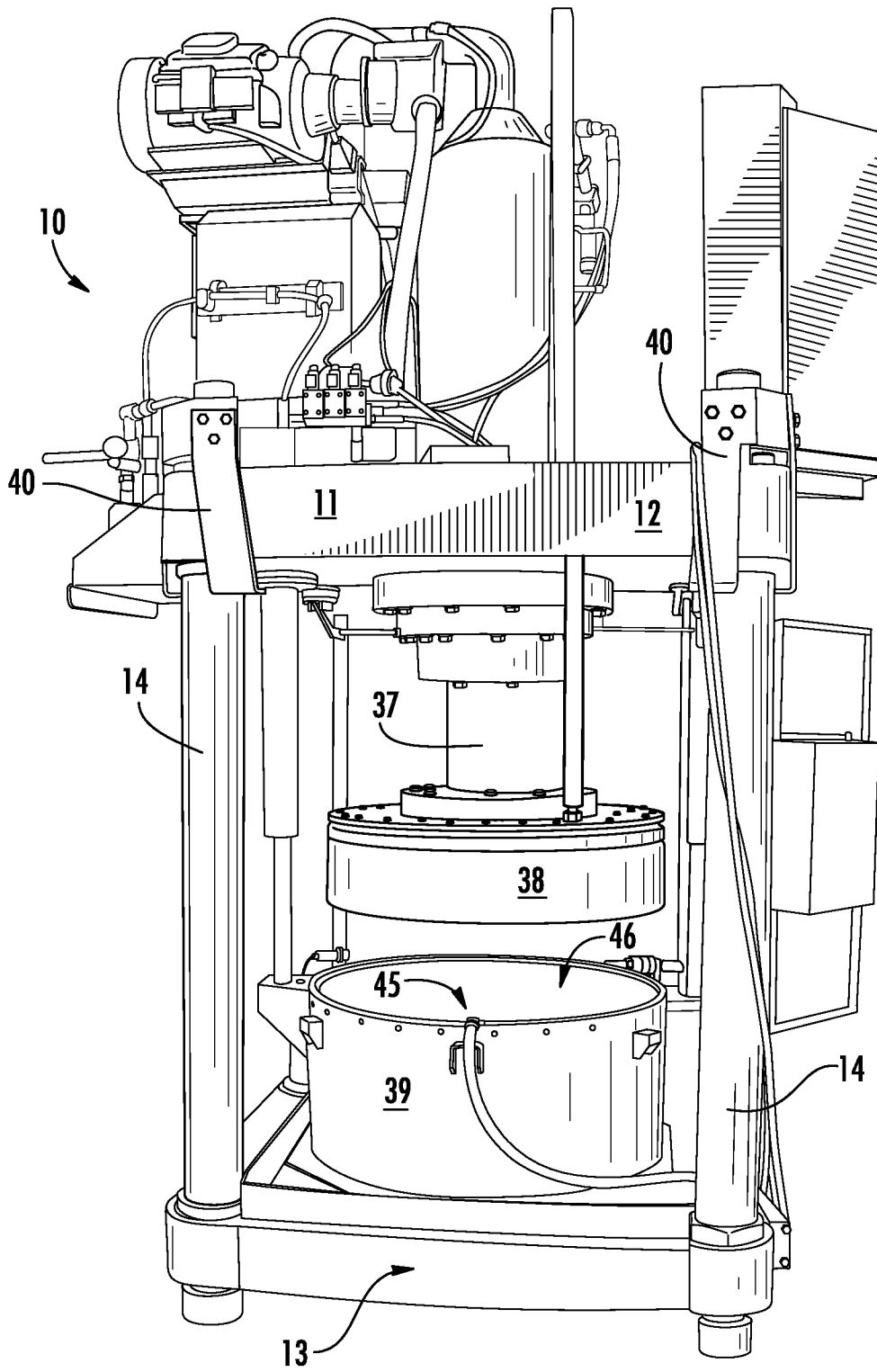

FIG. 14

INTERNATIONAL SEARCH REPORT

International application No.

PCT/US 2012/047219

A. CLASSIFICATION OF SUBJECT MATTER		
<i>D06F 47/00 (2006.01)</i>		
According to International Patent Classification (IPC) or to both national classification and IPC		
B. FIELDS SEARCHED		
Minimum documentation searched (classification system followed by classification symbols)		
D06F 47/00-47/06, 49/00-49/08, 51/00, F16B 37/00-37/14, F26B 5/00-5/14, B30B 9/00-9/26, 15/00-15/04, 9/00-9/20		
Documentation searched other than minimum documentation to the extent that such documents are included in the fields searched		
Electronic data base consulted during the international search (name of data base and, where practicable, search terms used)		
RUPAT, Esp@cenet, DWPI		
C. DOCUMENTS CONSIDERED TO BE RELEVANT		
Category*	Citation of document, with indication, where appropriate, of the relevant passages	Relevant to claim No.
Y	US 2010/0313440 A1 (PELLERIN MILNOR CORPORATION) 16.12.2010, para. [0024]-[0036], fig. 1-10	1-30
Y	SU 789283 A (VORONEZHSKOE PROIZVODSTVENNOE OBIEDINENIE PO VYPUSKU TYAZHOLYKH MEKHANICHESKIKH PRESSOV) 28.12.1980, col. 1-4, fig.1	1-30
Y	P.I.ORLOV. Osnovy konstruirovania. "Izdatelstvo Mashinostroenie", Moscow, 1968, p. 407-408	2-7, 10-15, 17-21, 24-30
Y	SU 387156 A (KOLESOV N.P. et al.) 29.10.1973, col. 103, fig. 1,2	3, 5-7, 11-15, 18, 20-22, 26-30
A	DE 102006030629 A1 (JENSEN-SENKING GMBH) 16.05.2007	1-30
A	JP 2009291499 A (MITSUBISHI HEAVY IND MACHI) 17.12.2009	1-30
<input checked="" type="checkbox"/> Further documents are listed in the continuation of Box C. <input type="checkbox"/> See patent family annex.		
* Special categories of cited documents:		
"A"	document defining the general state of the art which is not considered to be of particular relevance	"T" later document published after the international filing date or priority date and not in conflict with the application but cited to understand the principle or theory underlying the invention
"E"	earlier document but published on or after the international filing date	"X" document of particular relevance; the claimed invention cannot be considered novel or cannot be considered to involve an inventive step when the document is taken alone
"L"	document which may throw doubts on priority claim(s) or which is cited to establish the publication date of another citation or other special reason (as specified)	"Y" document of particular relevance; the claimed invention cannot be considered to involve an inventive step when the document is combined with one or more other such documents, such combination being obvious to a person skilled in the art
"O"	document referring to an oral disclosure, use, exhibition or other means	"&" document member of the same patent family
"P"	document published prior to the international filing date but later than the priority date claimed	
Date of the actual completion of the international search		Date of mailing of the international search report
12 October 2012 (12.10.2012)		22 November 2012 (22.11.2012)
Name and mailing address of the ISA/ FIPS Russia, 123995, Moscow, G-59, GSP-5, Berezhkovskaya nab., 30-1		Authorized officer V. Vasilieva
Facsimile No. +7 (499) 243-33-37		Telephone No. (495)531-64-81

INTERNATIONAL SEARCH REPORT

International application No.

PCT/US 2012/047219

C (Continuation). DOCUMENTS CONSIDERED TO BE RELEVANT		
Category*	Citation of document, with indication, where appropriate, of the relevant passages	Relevant to claim No.
A	GB 2158466 A (MARTIN KANNEGIESSER) 13.11.1985	1-30
A	EP 0143409 A2 (PASSAT MASCHINENBAU GMBH) 05.06.1985	1-30