

No. 732,012.

PATENTED JUNE 23, 1903.

J. F. SKIRROW.
SWITCHBOARD.

APPLICATION FILED OCT. 24, 1901.

NO MODEL.

2 SHEETS—SHEET 1.

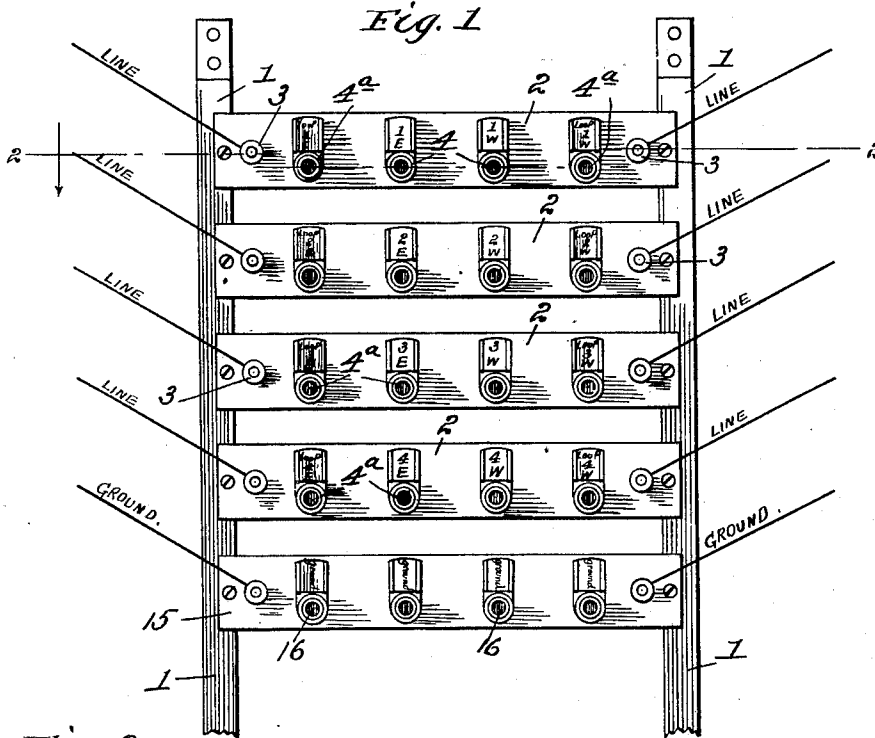
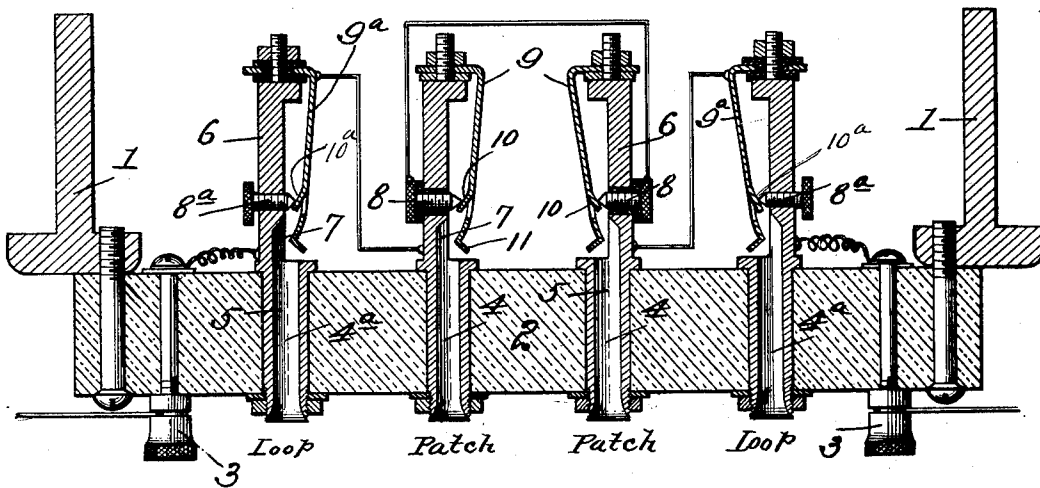

Fig. 2.



WITNESSES:

J. H. Griswell
L. M. Babbitt

INVENTOR

John F. Skirrow

BY

Davis & Davis
his ATTORNEYS

No. 732,012.

PATENTED JUNE 23, 1903.

J. F. SKIRROW.
SWITCHBOARD.

APPLICATION FILED OCT. 24, 1901.

NO MODEL.

2 SHEETS—SHEET 2.

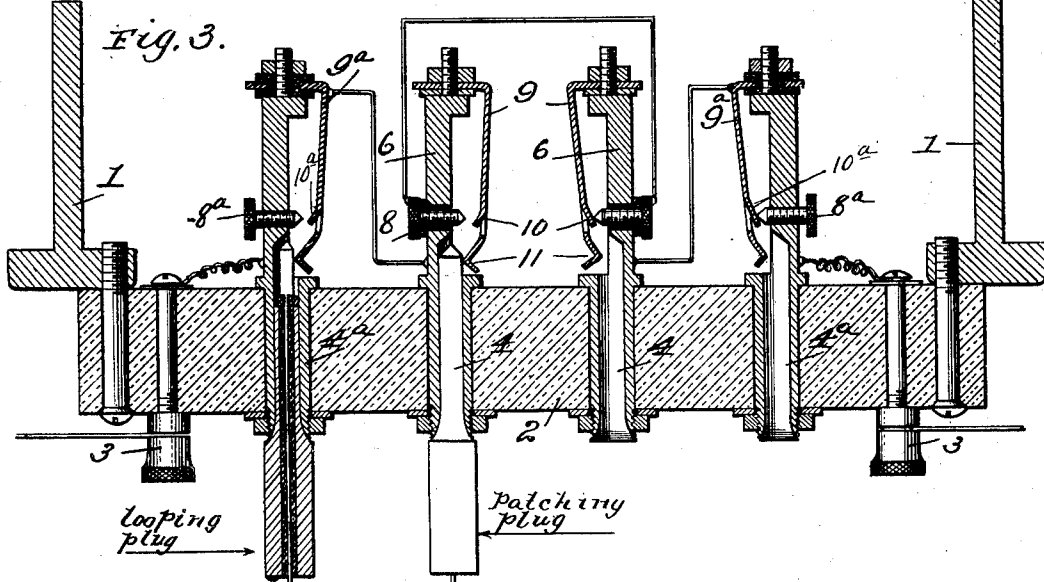

Fig. 5.

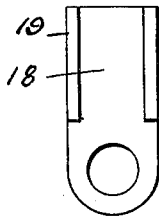

Fig. 6.

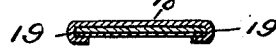

Fig. 4.

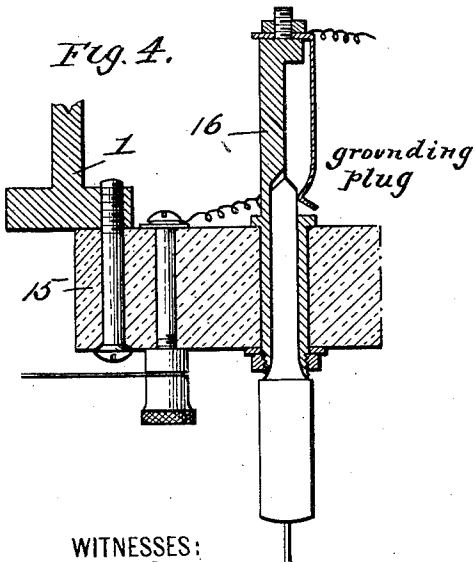
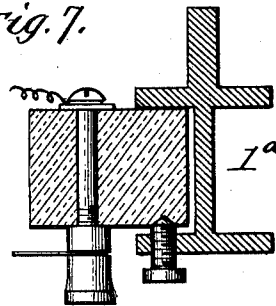

Fig. 7.



WITNESSES:

J. W. Criswell
M. Bassitt

INVENTOR

John F. Skirrow

BY

David Davis
his ATTORNEYS

UNITED STATES PATENT OFFICE.

JOHN F. SKIRROW, OF EAST ORANGE, NEW JERSEY, ASSIGNOR OF ONE-HALF TO CHARLES SHIRLEY, OF BROOKLYN, NEW YORK.

SWITCHBOARD.

SPECIFICATION forming part of Letters Patent No. 732,012, dated June 23, 1903.

Application filed October 24, 1901. Serial No. 79,821. (No model.)

To all whom it may concern:

Be it known that I, JOHN F. SKIRROW, a citizen of the United States, and a resident of East Orange, county of Essex, State of New Jersey, have invented a new and useful Improvement in Switchboards, of which the following is a specification, reference being had therein to the accompanying drawings, in which—

Figure 1 is a face view of the switchboard; Fig. 2, a horizontal sectional view taken on the line 2 2 of Fig. 1 through one of the terminal-bars; Fig. 3, a similar view showing a looping-plug and a patching-plug in position in their respective jacks. Fig. 4 is a horizontal sectional view of one end of the grounding-bar, showing a patching-plug in position in the grounding-jack; Figs. 5 and 6, views of the card-holder. Fig. 7 is a detail sectional view showing a modified form of the terminal-bar-fastening means.

In switchboards of the usual construction, wherein intersecting bars are connected to the line-wires and the bars are put in electrical connection with each other by means of plugs which are inserted at the intersecting point of the two bars which it is desired to connect, the great objection is that it requires a skilled operator to manipulate them. In fact, it is extremely difficult to prevent errors even when skilled operators are employed.

One object of the present invention is to produce a switchboard which may be manipulated by an unskilled operator and wherein the combinations of connections may be so easily made as to make it almost impossible for errors to occur.

Another object of this invention is to provide a switchboard which may be readily enlarged or made smaller—that is, so that additional pairs of wires may be added to it or some wires removed or disconnected therefrom—without in the least interfering with the proper manipulation of the board.

Referring to the various parts by numerals, 1 designates a pair of parallel supports spaced apart a sufficient distance and adapted to be secured in any suitable position. Connecting these supports are separated parallel terminal strips or bars 2 of suitable insulating

material, such as porcelain, these bars being connected at their ends to the supports in such a manner that they may be readily removed therefrom when desired. Each of these bars is provided with a pair of terminals or binding-posts 3, one of said posts being located near each end of the bar. To each of these binding-posts one end of a line-wire is connected. As illustrated in the drawings, each bar carries four connection jacks or devices, two of said jacks or devices 4 being “patching-jacks” and the other two, 4^a, being “looping-jacks,” these latter being adjacent the binding-posts and the patching-jacks being arranged between the looping-jacks, all of said jacks being normally-closed jacks—that is, the circuit through them is normally closed. Each line-wire is designated by a suitable symbol or symbols, such as “1 e” or “1 east” and “1 w” or “1 west,” and the looping-jack connected to said line-wire is designated by corresponding symbols and is further designated by being marked “Loop.” The patching-jack and the looping-jack of each wire bear corresponding indicating symbols, and the looping-jack is distinguished from the patching-jack by being also marked “Loop.” It will be noted that the two wires connected to each terminal-bar are designated by the same numeral, and to distinguish one of said wires from the other each is given a distinguishing letter or word, as “E” or “East.” It will also be seen that the numerals which designate the wires connected to the terminal-bars indicate the position of said bar—that is, the wires connected to the top terminal-bar are designated by the numeral “1,” those connected to the second bar are designated by the numeral “2,” and so on, so that it is a simple matter to locate the desired wire quickly.

Each patching-jack is formed of a tubular body portion 5, which is secured within a perforation in the bar 2 and is formed integral with a rearward-extending shank 6, in which is formed a semicylindrical longitudinal socket 7, into which the inner end of the patching-plug extends. Through the shank 6 beyond the inner end of the socket extends a contact-point 8, and secured to the rear end of the shank 6 and in circuit therewith is a

spring contact-plate 9, whose forward end is provided with an inward-extending forward-inclined lip 10, which normally bears on the end of the contact-point 8. The lip 10 is placed at such an angle that it will be forced against the point 8 with a wedging or wiping action. The purpose of this is to keep the contact-surfaces clean and bright and to prevent the lodgment thereon of dust or any material which may prevent a good contact. The forward end of the spring contact-plate is extended into the path of the patching-plug and is then inclined outward to form the inclined finger 11, against which the inner end of the patching-plug will strike when said plug is forced through the tubular part of the jack. The contact-point 8 is insulated from the body of the patching-jack, so that when the patching-plug contacts with the inclined finger on the spring contact and forces its lip 10 away from the contact-point 8, as shown in Fig. 3, the circuit through the spring contact-plate and the contact-point will be broken, and the current will then pass from the body of the jack through the patching-plug and the conductor connected thereto.

The looping-jacks are of the same structure as the patching-jacks, except that in them the contact-points 8^a are not insulated from the body of the jack and the spring contact-plates 9^a are insulated from the body of the jack. The wires connected to the binding-posts of each terminal-bar are connected in circuit through the adjacent looping-jacks carried by said terminal-bar, as will be readily understood from Fig. 2 of the drawings. Each wire is provided with a patching-jack and a looping-jack.

At any suitable point on the supports 1 is secured a grounding-bar 15, which is formed of suitable insulating material, such as porcelain, and carries a suitable number of grounding-jacks 16, which may be of any suitable construction and are grounded in any suitable manner. These grounding-jacks are adapted to be connected to the patching-jacks by the ordinary patching-plug. Each jack is provided with a card-holder which consists of a back plate 18, formed at its edges into retaining-flanges 19, which are adapted to receive and hold a card bearing the symbols employed to designate the wire connected to the jacks. The lower end of the back plate is perforated to adapt it to be passed over the projecting end of the tubular part of the jack, the plate being secured in position against the face of the terminal-bar by means of a nut which is screwed onto the end of the tubular part of the jack and clamps the jack and the card-holder in position.

As shown in Figs. 2, 3, and 4, the terminal-bars are secured to the supports 1 by means of screws which pass through the bars and into the supports.

In Fig. 7 is shown a slightly-modified form of securing means. In this view the ends of the terminal-bars are secured between the

flanges of a channel-iron support 1^a by means of a screw which passes through the outer flange of the support and bears at its inner end on the outer face of the bar.

By the terms "patching-jacks" and "looping-jacks" I desire it understood that I may employ any devices by which the "patching" and "looping" connections may be made, and I therefore do not wish to be limited to the construction of the devices shown in the drawings. The term "patching" as used in the specification refers to the act of connecting the end of one line to the end of another line by means of a short link or conductor, and single-contact patching-plugs, which are connected together in pairs by a single flexible conductor, and patching-jacks which are connected to the lines are employed for this purpose.

The operation is as follows: Should it be desired to connect the wire designated by the symbols "1 e" to any other wire on the switchboard except the wire designated by the symbol "1 w," a single-contact patching-plug is inserted in the jack designated "1 e," and the other end of the patching-plug is then inserted in the patching-jack of the wire to which it is desired to connect the wire "1 e"—that is, if it is desired to connect wire "1 e" to wire "4 w" one end of the patching-plug is inserted into the patching-jack "1 e" and the other end is inserted in the patching-jack "4 w." By inserting the patching-plug in the jack "1 e" it will be noted that the circuit will be broken through the patching-jack, and the current will flow from the shank of the jack out through the patching-plug and that the patching-jack "1 e" will be disconnected from the patching-jack "1 w." It will also be noted that a similar operation will be performed by inserting the other end of the patching-plug into the patching-jack "4 w"—that is, that said patching-jack "4 w" will be electrically disconnected from the patching-jack "4 e" and the current will flow through the shank of the patching-jack "4 w" and through the patching-plug. It will thus be seen that in order to connect any one of the wires carried by any of the terminal bars to any other wire connected to the switchboard it will simply be necessary to insert the ends of a patching-plug in the patching-jacks of the wires which it is desired to connect. Whenever it is desired to "loop in" on any wire, it is simply necessary to insert the usual double-contact looping-in plug into the looping-jack connected to the wire which it is desired to loop into. Thus if it be desired to loop into the wire "1 w" it will simply be necessary to insert a looping-in plug in the looping-in jack designated "Loop 1 w." The result of this is that the inner end of the looping-in plug contacts with the inclined finger formed on the forward end of the spring contact-plate 9^a and forces said contact-spring outward, disconnecting the lip 10^a from the contact-point and causing the

current to flow through the shank of the looping-jack out through the plug and then back again through the contact-spring 9^a. Whenever it is desired to ground any of the wires, it is simply necessary to insert one end of an ordinary patching-plug in the patching-jack of the wire it is desired to ground and to insert the other end of the said plug into one of the grounding-jacks carried by the grounding-bar. Whenever it is desired to open a wire, it is simply necessary to insert a patching-plug in the patching-jack of that wire, as will be readily understood from Fig. 3.

It will be readily understood that terminal-bars and grounding-bars may be added to the switchboard, if desired, as each bar and the wires and jacks carried thereby are entirely independent of the jacks and wires carried by all of the other terminal-bars. It will also be seen that any terminal-bar may be removed whenever it is desired should any of the jacks become broken or should it be desirable for any other reason to remove one terminal-bar and replace it by a new one, this being accomplished without in the least interfering with the proper operation of the remaining parts of the switchboard. Grounding-bars may also be added whenever it is desired, and they may be placed at any convenient point in the switchboard.

From the foregoing it will be readily seen that the switchboard may be manipulated by an unskilled person without the least danger of error in making the proper combinations of connections unless the operator be grossly careless.

Any desired system of symbols for designating the wires and the jacks connected thereto may be employed.

Having thus described my invention, what I claim as new, and desire to secure by Letters Patent, is—

1. A switchboard carrying a patching-jack and a looping-jack, the patching-jack consisting of a body portion, a movable contact and a rigid contact point insulated from the body portion, the movable contact normally engaging the insulated contact; the looping-jack consisting of a body portion, a fixed contact-point in circuit therewith, a movable contact insulated from the body portion and normally engaging the fixed contact; means electrically connecting the insulated contact of the looping-jack to the movable contact of the patching-jack, the insulated contact of the patching-jack being connected to one end of the line, and the fixed contact of the looping-jack being electrically connected to the other end of the line.

2. A switchboard carrying a plurality of patching-jacks, and a plurality of looping-jacks, each patching-jack consisting of a body portion, a movable contact in circuit therewith, and a contact-point insulated therefrom, the movable contact normally engaging the insulated contact; each of the looping-jacks consisting of a body portion, a fixed

contact in circuit therewith, a movable contact insulated from the body portion and normally engaging the fixed contact, means connecting together the insulated contacts of the patching-jacks, the insulated contacts of the looping-jacks being electrically connected to the movable contacts of the patching-jacks, and the fixed contacts of the looping-jacks being connected to the ends of the line.

3. A terminal-bar for a switchboard, carrying a patching-jack and a looping-jack, the patching-jack consisting of a body portion, a movable contact, and a fixed contact insulated from the body of the jack, the movable contact normally engaging the insulated contact; the looping-jack consisting of a body portion, a fixed contact, a movable contact insulated from the body portion and normally engaging the fixed contact, means electrically connecting the insulated contact of the looping-jack to the movable contact of the patching-jack, the insulated contact of the patching-jack being connected to one end of the line, and the fixed contact of the looping-jack being electrically connected to the other end of said line, whereby the circuit through the patching-jack may be broken by the insertion of a single-contact patching-plug in said jack.

4. A terminal-bar for a switchboard, carrying a patching-jack and a looping-jack, the patching-jack consisting of a body portion, a movable contact, and a fixed contact insulated from the body portion, the movable contact normally engaging the insulated contact; the looping-jack consisting of a body portion, a fixed contact-point, a movable contact insulated from the body portion and normally engaging the fixed contact, means electrically connecting the insulated contact of the looping-jack to the movable contact of the patching-jack, the insulated contact of the patching-jack being connected to one end of the line, and the fixed contact of the looping-jack being electrically connected to the other end of the line, in combination with a single-contact patching-plug adapted to engage the patching-jack, and break the circuit between the movable contact and the insulated contact thereof.

5. A switchboard carrying a pair of patching-jacks, and a pair of looping-jacks, each patching-jack consisting of a body portion, a movable contact, and a contact insulated from the body portion, the movable contact normally engaging the insulated contact; each of the looping-jacks consisting of a body portion, a fixed contact, a movable contact insulated from the body portion and normally engaging the fixed contact, means for electrically connecting the insulated contacts of the looping-jacks to the non-insulated contacts of the patching-jacks, the insulated contacts of the patching-jacks being electrically connected together, the non-insulated contacts of the looping-jacks being connected to the line.

6. A switchboard, comprised of a series of terminal-bars mounted on suitable supports, each bar carrying a patching-jack and a looping-jack, the patching-jack consisting of a body portion, a movable contact in circuit therewith, and a contact-point insulated therefrom, the movable contact normally engaging the insulated contact; the looping-jack consisting of a body portion, a fixed contact-point in circuit therewith, a movable contact insulated from the body portion and normally engaging the fixed contact, means electrically connecting the insulated contact of the looping-jack to the movable contact of the patching-jack, the insulated contact of the patching-jack being connected to the one end of the line, and the fixed contact of the looping-jack being electrically connected to the other end of the line, the jacks carried by each bar being normally out of circuit with the jacks carried by the other bars.

7. A switchboard, comprised of a series of parallel rows of jacks, each row of jacks comprising a pair of patching-jacks and a pair of looping-jacks, the patching-jacks being located between the looping-jacks, each of said patching-jacks being provided with a movable contact in circuit with the adjacent looping-jack, and an insulated contact, the insulated contact of one patching-jack being electrically connected to the insulated contact of the other patching-jack whereby the circuit through the patching-jacks may be broken by separating the contacts of either of said jacks.

8. A terminal-bar, for a switchboard, carrying a pair of patching-jacks and a pair of looping-jacks, the patching-jacks being located between the looping-jacks, each of said patching-jacks consisting of a body portion, a fixed contact, and a movable contact one of said contacts being insulated from the body portion and normally in contact, corresponding contacts of each patching-jack being electrically connected to the adjacent looping-plug, the other pair of corresponding contacts of the patching-jacks being electrically connected together, means for connecting the looping-plugs to each end of the line, and

means for detachably connecting the bar to a suitable support.

9. A terminal-bar, for a switchboard, formed of non-conducting material and carrying a pair of patching-jacks, and a pair of looping-jacks, the patching-jacks being located between the looping-jacks, each of said patching-jacks consisting of a body portion, a fixed contact and a movable contact, one of said contacts being insulated from the body portion and normally in contact, corresponding contacts of each patching-jack being electrically connected to the adjacent looping-plug, the other pair of corresponding contacts of the patching-jacks being electrically connected together, means for connecting the looping-plugs to each end of the line, and means for detachably connecting the bar to a suitable support.

10. A switchboard comprising a pair of patching-jacks, each jack consisting of a body portion, a movable contact, and a rigid contact insulated from the body portion, the movable contact normally engaging the insulated contact; a terminal-wire electrically connected to the body portion of each jack, and means independent of the movable contacts and electrically connecting together the rigid contacts of the two jacks.

11. A terminal-bar for a switchboard carrying a pair of patching-jacks, each of said jacks consisting of a body portion, a movable contact, and a rigid contact insulated from the body portion, the movable contact normally engaging the insulated contact; a terminal-wire electrically connected to the body portion of each jack, and means independent of the movable contacts electrically connecting together the rigid contacts of the two jacks, and means for detachably connecting the said bar to a suitable support.

In testimony whereof I hereunto affix my signature, in the presence of two witnesses, this 22d day of October, 1901.

JOHN F. SKIRROW.

Witnesses:

THEODORE L. CUYLER, Jr.,
JOSEPH J. CARDONA.