

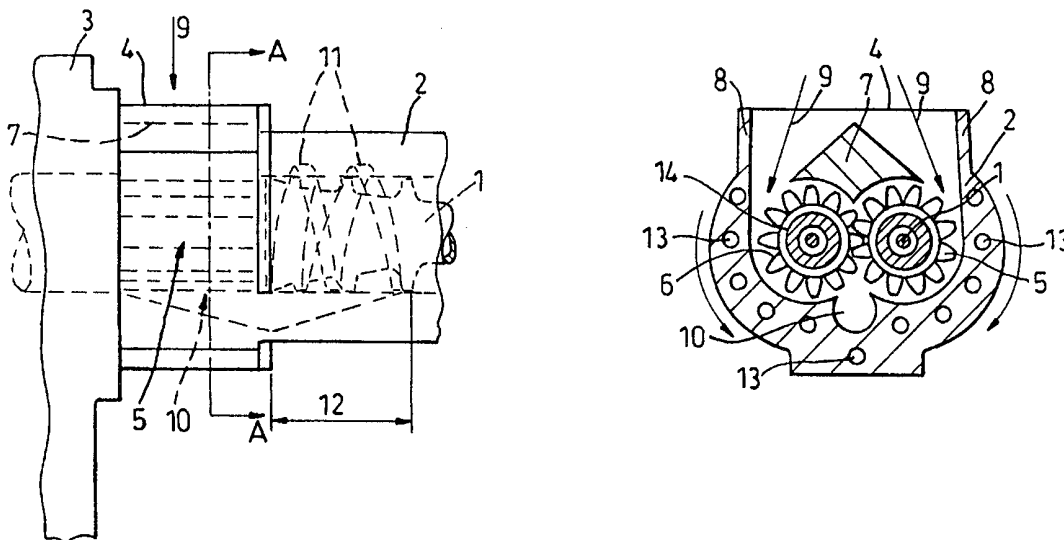

INTERNATIONAL APPLICATION PUBLISHED UNDER THE PATENT COOPERATION TREATY (PCT)

<p>(51) International Patent Classification ⁷ : B29C 47/50, 47/58, 47/10, 47/38</p>	A1	<p>(11) International Publication Number: WO 00/53390</p> <p>(43) International Publication Date: 14 September 2000 (14.09.00)</p>								
<p>(21) International Application Number: PCT/GB00/00899</p> <p>(22) International Filing Date: 10 March 2000 (10.03.00)</p> <p>(30) Priority Data:</p> <table border="0"> <tr> <td>9905487.6</td> <td>11 March 1999 (11.03.99)</td> <td>GB</td> </tr> <tr> <td>9908143.2</td> <td>10 April 1999 (10.04.99)</td> <td>GB</td> </tr> <tr> <td>9916725.6</td> <td>19 July 1999 (19.07.99)</td> <td>GB</td> </tr> </table> <p>(71) Applicant (for all designated States except US): A-Z FORMEN-UND MASCHINENBAU GMBH [DE/DE]; Dessauerstrasse 9, D-80992 München (DE).</p> <p>(72) Inventor; and</p> <p>(75) Inventor/Applicant (for US only): MEYER, Paul [GB/CH]; Via Locarno, 27B, CH-6612 Ascona (CH).</p> <p>(74) Agent: BARKER BRETTELL; 138 Hagley Road, Edgbaston, Birmingham B16 9PW (GB).</p>	9905487.6	11 March 1999 (11.03.99)	GB	9908143.2	10 April 1999 (10.04.99)	GB	9916725.6	19 July 1999 (19.07.99)	GB	<p>(81) Designated States: AE, AL, AM, AT, AU, AZ, BA, BB, BG, BR, BY, CA, CH, CN, CR, CU, CZ, DE, DK, DM, DZ, EE, ES, FI, GB, GD, GE, GH, GM, HR, HU, ID, IL, IN, IS, JP, KE, KG, KP, KR, KZ, LC, LK, LR, LS, LT, LU, LV, MA, MD, MG, MK, MN, MW, MX, NO, NZ, PL, PT, RO, RU, SD, SE, SG, SI, SK, SL, TJ, TM, TR, TT, TZ, UA, UG, US, UZ, VN, YU, ZA, ZW, ARIPO patent (GH, GM, KE, LS, MW, SD, SL, SZ, TZ, UG, ZW), Eurasian patent (AM, AZ, BY, KG, KZ, MD, RU, TJ, TM), European patent (AT, BE, CH, CY, DE, DK, ES, FI, FR, GB, GR, IE, IT, LU, MC, NL, PT, SE), OAPI patent (BF, BJ, CF, CG, CI, CM, GA, GN, GW, ML, MR, NE, SN, TD, TG).</p> <p>Published <i>With international search report.</i> <i>Before the expiration of the time limit for amending the claims and to be republished in the event of the receipt of amendments.</i></p>
9905487.6	11 March 1999 (11.03.99)	GB								
9908143.2	10 April 1999 (10.04.99)	GB								
9916725.6	19 July 1999 (19.07.99)	GB								

(54) Title: SINGLE ROTOR EXTRUDERS



(57) Abstract

A single rotor extruder for an elastomeric or plastics medium has a casing (2) in which an extruder screw (1) works with a Transformix section and includes a gear pump comprising a casing and at least two gear wheels (5, 6), the gear pump casing being integral with the casing (2) of the extruder, and one gearwheel (5 or 6) of the gear pump being coaxial with the extruder screw (1). The gear pump is integrated with the extruder screw, which has advantages in controlling the temperature, output and throughput of the medium. The gear pump may be arranged before or after the extruder screw (1).

FOR THE PURPOSES OF INFORMATION ONLY

Codes used to identify States party to the PCT on the front pages of pamphlets publishing international applications under the PCT.

AL	Albania	ES	Spain	LS	Lesotho	SI	Slovenia
AM	Armenia	FI	Finland	LT	Lithuania	SK	Slovakia
AT	Austria	FR	France	LU	Luxembourg	SN	Senegal
AU	Australia	GA	Gabon	LV	Latvia	SZ	Swaziland
AZ	Azerbaijan	GB	United Kingdom	MC	Monaco	TD	Chad
BA	Bosnia and Herzegovina	GE	Georgia	MD	Republic of Moldova	TG	Togo
BB	Barbados	GH	Ghana	MG	Madagascar	TJ	Tajikistan
BE	Belgium	GN	Guinea	MK	The former Yugoslav Republic of Macedonia	TM	Turkmenistan
BF	Burkina Faso	GR	Greece	ML	Mali	TR	Turkey
BG	Bulgaria	HU	Hungary	MN	Mongolia	TT	Trinidad and Tobago
BJ	Benin	IE	Ireland	MR	Mauritania	UA	Ukraine
BR	Brazil	IL	Israel	MW	Malawi	UG	Uganda
BY	Belarus	IS	Iceland	MX	Mexico	US	United States of America
CA	Canada	IT	Italy	NE	Niger	UZ	Uzbekistan
CF	Central African Republic	JP	Japan	NL	Netherlands	VN	Viet Nam
CG	Congo	KE	Kenya	NO	Norway	YU	Yugoslavia
CH	Switzerland	KG	Kyrgyzstan	NZ	New Zealand	ZW	Zimbabwe
CI	Côte d'Ivoire	KP	Democratic People's Republic of Korea	PL	Poland		
CM	Cameroon	KR	Republic of Korea	PT	Portugal		
CN	China	KZ	Kazakstan	RO	Romania		
CU	Cuba	LC	Saint Lucia	RU	Russian Federation		
CZ	Czech Republic	LI	Liechtenstein	SD	Sudan		
DE	Germany	LK	Sri Lanka	SE	Sweden		
DK	Denmark	LR	Liberia	SG	Singapore		
EE	Estonia						

SINGLE ROTOR EXTRUDERS

This invention relates to single rotor extruders for elastomers and plastics
5 including plasticizing/mixing sections, and more particularly to those
where such plasticizing/mixing sections are of the Transfermix type, as
disclosed in GB 842 692, GB 1 585 531 and GB 1 581 532.

Such extruders are in use in the rubber industry at several positions in
10 the mixing-compounding-shaping chain from raw rubber to a processed
product prior to vulcanisation, when the compound finally also contains
the vulcanising chemicals. Such products may be hose, pipe or cable
covering, or semi-finished products to be assembled with others prior to
vulcanisation. For a tyre there are treads, side-wall, components of the
15 casing etc..

In present industrial practice, the first mixing-machine is generally the
internal mixer, which functions batch-wise in combining a rubber
compound out of its components. For bulk use, such as in the tyre-
20 industry, mills after internal mixers have for many compounds, but by no
means for all of them, been replaced by so-called dump-extruders, used
for handling the drop from the internal mixer and for shaping it into sheet
without doing additional mixing work. As a sub-species of these,
Transfermix extruders, such as shown in US 26 147(Parshall & Geyer)
25 and GB 842 692 (M.Frenkel) were originally used to impart measurable
amounts of mixing in addition to the dump-extruder functions. At times,
these dump-extruders produced pellets instead of sheet, as the product
going into the cooling line. Compared to normal cold feed extruders,
these machines would be vastly oversized for their output on account of
30 having to fit the outlet end of the drop-shaft of the internal mixer and also

of having to keep screw speeds low to avoid overheating. For example, for a maximum output of about 6 t.p.h., of a Banbury No. 11 size of internal mixer on a short cycle, these would be sized 18"/15" (420/375mm) inlet/outlet-diameter, compared to a 250 mm cold feed
5 extruder.

In cold feed extruders and Transfermix, including the later generations of GB 1 585 531 and GB 1 581 532 (P. Meyer), the functions of moving the medium and of mixing/plasticizing devolve on the single screw rotor.
10 However, the bigger the screw-diameters, involving screw-channels of greater depth, the more sensitive to pressure-backflow due to die-resistance and throttling the extruders become. Thus, in Transfermix, easy-to-plasticize rubber compounds such as those based on SBR, which require little or no throttling, can be extruded at high outputs, but for
15 some compounds requiring a high specific mechanical work-input by means of throttling, the output could be reduced to impracticable levels for the extruder-size in question.

It is known in the art to provide single-screw extruders with a gear pump
20 between the end of the screw and the die-head or strainer. This relieves the extruder from having to provide the pressure-build-up needed to overcome the high resistance of these devices, leaving it only with the task of feeding the gear pump and keeping it full. Also, gear pumps, as volumetric pumps, will improve the uniformity of the output by
25 smoothing out irregularities in the feed. Further, as they put very little mechanical work into the medium even when generating high pressures against a strainer or a die, they even improve the overall energy balance of the combination of extruder and gear pump.

However, because it requires separate drives and control devices for keeping synchronous with the extruder, this combination has proved cost-effective only for special, high precision applications involving small dies and/or straining, as e.g. in cable covering. EP 0 642 913 shows a
5 single-screw extruder with an integrated gear pump for use with highly viscous materials such as polymers and thermoplastics. Integration of the gear pump and the extruder screw simplifies construction and control.

The use of stand-alone gear pumps as cold feed extruders for a limited
10 range of soft elastomers dates from about 1996 for strainering and calander feeding, DE 196 02 091 Uth, EP 0 816 049 Troester, EP 0 857 559 Berstorff.

Recent developments also provide gear pumps as feed devices for cold
15 feed extruders, as disclosed in EP 0 816 048 Troester and WO 98/09792 Limper. The drawback here is that gear pumps will draw in air when the feed is irregular, even within the normal dimensions of feed-strips or sheets. This air has to be extracted before the extrusion takes place at the cost of mechanical complication and attendant expense, as disclosed by
20 these references. Also these devices are limited to media which will feed into gear pumps when cold, for which some compounds e.g. as used in the tyre industry, are quite unsuitable.

For Transfermix designed as after-mixers to internal mixers, or for drop-
25 extruders, ram-feeders and twin-screw force feed devices with separate drives have been used in order to keep the feed sections full. Cold feed extruders have driven feed-rolls integrated into their feed-openings for the same reason.

30 To sum up: in order to avoid excessive temperature of the medium

- a. on exiting an internal mixer oversize dump-extruders must be used;
 - b. in cold feed extruders oversize machines are used and, for a range of compounds of practical importance, hot feed extruders only can be used;
 - c. in both these applications costly and maintenance-intensive feed-aids
- 5 are necessary to try and keep the screw transporting, and exclude air.

The invention aims to overcome these drawbacks.

According to the invention, a single rotor extruder for an elastomeric or
10 plastics medium has a casing in which an extruder screw works and
includes a gear pump comprising a casing and at least two gear wheels,
the gear pump casing being integral with the casing of the extruder, and
one gear wheel of the gear pump being co-axial with the extruder screw,
the extruder having a Transfermix section formed where the extruder
15 screw has a part with an external helical thread working in a barrel part of
the casing with an internal helical thread of opposite hand but coaxial with
the external thread, the helical threads facing each other to define a
passage for the medium, and the cross-sectional areas of the grooves of
the threads varying in opposite senses between a maximum value and a
20 minimum value along the same length of the passage, the gear pump being
located adjacent the Transfermix section.

The invention integrates a gear pump with its positive metering action
25 into a single rotor extruder as a unitary device, which with regard to its
output is less back-pressure dependent or in which the throughput is
independent of the transport-action of the screw itself. This is particularly
advantageous where the extruder includes a Transfermix section, which is
itself efficient at mixing and transporting the material and enables
30 mechanical work to be imparted to the medium in a controlled way. The

combination of gear pump and Transfermix extruder has advantages in controlling the temperature, output and throughput of the medium.

An outlet from the gear pump may lead to an inlet of the extruder, 5 Transfermix section, so that the extruder screw follows the gear pump. Alternatively, an outlet from the extruder Transfermix screw may lead to an inlet of the gear pump, that is, the gear pump follows the extruder screw.

10

Conveniently the coaxial gear wheel and the shaft of the extruder screw are connected fixedly to rotate together.

Alternatively, the said coaxial gear wheel and the shaft of the extruder 15 screw are mounted to be independently rotatable, and the other gear wheel of the gear pump has a separate drive to provide for the coaxial gear wheel a rotational speed different from that of the extruder screw.

A further alternative is for the said coaxial gear wheel and the shaft of the 20 extruder screw to be connected by a transmission which provides for a step-wise or continuously variable ratio between the rotational speed of the gear wheel and that of the extruder screw.

The gear pump casing preferably has an outlet passage at the outlet high 25 pressure side of the gear pump starting at substantially zero at one end of the gear pump and increasing progressively until at the other end of the gear pump it has a cross-section for full flow of the medium. Where the gear pump feeds the extruder screw, the outlet passage preferably continues as a feed passage in the extruder casing, open towards the screw 30 over an initial feed length with a cross-section continuously decreasing to

zero to feed the medium into the Transfermix screw. This provides a smooth feed from the gear pump to the Transfermix screw.

The feed passage is preferably in the shape of a spiral of opposite hand to that of the extruder screw, and over the feed length of the feed passage
5 the cross-sectional area of the screw increases from a zero initial cross-section to a full cross-section, thereby forming a Transfermix section.

Conveniently the feed passage winds around the extruder screw in the
10 opposite hand to the screw as it reduces in cross-sectional area from full to zero. This also smoothes the flow of medium and forms a Transfermix section with its attendant advantages.

In one embodiment where the gear pump is arranged at the feed inlet of
15 the extruder, the gear pump has a feed inlet for feeding sheet, strip or pellets of medium into a single intake nip between one gear wheel and the casing wall. The Transfermix section of the extruder enables any further mechanical work to be imparted to the medium in a controlled way.

20 The gear wheel defining the single intake nip is preferably of larger diameter than the other gear wheel of the gear pump. The larger gear wheel acts as a heat exchanger, as the medium entrained by it will have a relatively longer residence time than it would have if also fed into the smaller gear wheel, allowing for better heat exchange. This enables a
25 greater range of medium to be extruded.

The extruder according to the invention may be used as a dump extruder-mixer, the extruder having a substantially rectangular drop opening and with the feed side of the gear pump forming the inlet of the
30 said dump extruder, the outlet from the internal mixer and the extruder

inlet being connected by a drop chute, where the length of the gear wheels is chosen to accommodate the depth of the said drop chute, and pump means, gland means and a vacuum pump being provided to enable the drop chute to be operated under vacuum. This enables air inclusions in the feed of the gear pump to be prevented in spite of voids occurring within the teeth of the gear pump.

It has been found that such a single rotor dump extruder of the Transfermix type, can surprisingly be considerably smaller than those used hitherto, and cooling can be applied to the drop, as well as air excluded from it.

The non-coaxial gear wheel may be of considerably larger diameter than the extruder screw for the total width of the gear pump inlet, to accommodate the width of the drop chute.

One or both of the gear wheels may be enlarged in diameter and/or length such as to accommodate the required throughput. The gear wheels preferably have a small modulus in order to provide an enhanced cooling capacity.

The extruder may also be used as a cold feed Transfermix extruder having a conventional feed section suited to compounds which will not feed into a gear pump. In this case the gear pump will be situated along the extruder screw, following the Transfermix section in which plastification will have taken place, preferably one in which the medium was transferred from the screw into the barrel in which the medium will then be flowing, the extruder having a transition section in which the casing is shaped to conduct the flow to the inlet side of the gear pump in a passage which, at least in part, is shaped to wind around the screw-shaft in the same

handedness as the barrel grooves whereby the rotation of the shaft contributes to the forward transport of the medium for a substantial part of the length of the transition section to the gear pump inlet.

- 5 For a cold feed extruder with conventional feed inlets, including a gear pump provides a smaller speed of rotation of the screw and thus mechanical work-input due thereto, for a throughput independent of, and generally larger than that achievable by the screw, especially in sizes of units > 120 mm \varnothing . Additionally, it provides an effective internal cooling
10 capacity to reduce the temperature of the medium to a required level prior to its reaching the extrusion head.

Various embodiments of the invention will now be described in some detail and by way of example with reference to the accompanying
15 drawings in which:

Figure 1 is a longitudinal section through an extruder with a gear pump feed section having one gear wheel coaxial with the extruder which can serve as a cold-feed extruder with the gear pump
20 warming and pre-plasticizing the feed or as a dump extruder cooling and working the drop from an internal mixer;

Figure 2 is a cross-section on A-A through the gear pump section of Figure 1;

25

Figure 3 is a longitudinal section of an alternative embodiment of a feed-section featuring one enlarged gear wheel in order to fit a given width of a drop-chute of an internal mixer and also in order to provide more cooling surface;

30

Figure 4 is similar to Figure 1, but showing a modification;

Figure 5 is a cross-section on the line E - E of Figure 4.

5 **Figure 6** is an outside view of a cold feed Transfermix extruder with an integrated gear pump cooler following the Transfermix section and driven by the Transfermix screw;

10 **Figure 7** is an outside view of a cold-feed Transfermix extruder with an integrated gear pump cooler following the Transfermix section with one gear wheel being co-axial with the Transfermix screw but independently rotatable and the other gear wheel having a separate, external driving means;

15 **Figure 8** is a cross-section through the Transfermix cold feed extruder of Figure 6, on line B-B, showing the outlet cross-section of the Transfermix barrel;

20 **Figure 9** is a part-cross-section on line D - D through Figure 6 showing the gear pump wheels and the entry and exit feed-channels thereof;

25 **Figure 10** is a part-cross-section on line C - C of Figure 6 showing a throttle, in this example, of the rotary ring type mounted after the end of the Transfermix barrel in the open position; and

Figure 11 is a part-cross-section on line C - C of Figure 6 showing the throttle of Figure 8 in an almost closed state.

30 The embodiment of Figures 1 and 2 shows a single rotor Transfermix

extruder for an elastomeric or plastics medium, with a gear pump followed by an extruder screw, which can serve as a cold feed extruder with the gear pump warming and pre-plasticizing the feed or as a dump extruder cooling and working the drop from an internal mixer. 1 denotes the screw of an extruder working in an extruder casing 2. The screw 1 is rotatably mounted and driven through a gearbox 3 in the casing 2. The inlet for the medium, which may be in the form of a hot drop from an internal mixer, of feed-strip or feed-sheet or pellets, is indicated at 4. Taking up substantially the axial length of the inlet 4 there is mounted a gear wheel 5 of a gear pump on the shaft of the extruder screw 1 so as to rotate at the same speed. 6 denotes the second gear wheel of the pump, being engaged and driven by wheel 5. Inside the feed inlet, a divider 7 splits and then deflects portions of the feed 9 into the spaces between the side-walls 8 of inlet 4 and into the nips of gearwheels 5 and 6. The exact shape of the divider 7 will depend on the nature of the feed, e.g. it will be much larger if the feed is in the form of two sheets or strips, each of which is guided to the nip of one of the gears with the wall 8.

On the output side of the gear pump, an outlet 10, shown in Figure 1 by dotted lines, extends in the axial direction of the gear wheels and of the screw, increasing in cross-sectional area up to the end of the gear wheels. Following this position, the extruder screw starts with zero depth of its helical grooves. The depth of the grooves increases to full depth over the same length 12 in which the continuation of outlet 10 reduces to zero depth. This continuation is also shown in dotted lines and splits into two channels 11 which are shaped to wind around the screw, but in opposite hand thereto. In this way, the screw and the channels 11 over this length already form a Transfermix section.

As the pressure-build-up for the medium is provided by the gear pump, there is no need for a compression section for this purpose, as in a conventional extruder, and the plasticizing section of a geometry suitable to the process requirements of the medium, may follow immediately. In
5 this way, the extruder can be kept very short.

Passages 13 for a tempering medium are provided in the casing 2. These may well be parts of different circuits for the gear pump and for the extruder. Similarly, passages 14 will be provided in the gear wheels for
10 tempering these. For the driving gear these may carry through into the extruder screw or another set of ducts (not shown) may provide another level of tempering there.

In the embodiment of Figure 3, like numerals have been applied to like
15 parts. In Figure 3, the driven gear 15 of the gear pump has an enlarged diameter in order that the total width of an inlet 16 can fit the width of a drop-chute 18 of the internal mixer. The end of the drop-chute 18 is fitted with the suction head 19 of a vacuum pump so that even with no medium being drawn in somewhere locally along the nip of the one or the other
20 gear, air inclusions will be without practical effect.

The divider 17 of the inlet has to be made suitably asymmetrical. At its apex it is provided with a knife 20 which may be of the vibratory type, for splitting the drop as it falls down the chute.
25

As the driven gear will rotate more slowly in ratio of the diameters, both gears will still pump equal amounts of the medium.

The embodiment of Figures 4 and 5 is a modification of the embodiment
30 of Figures 1 and 2, and corresponding reference numerals have been

applied to corresponding parts. In Figures 4 and 5 one gear wheel of the gear pump, as shown the driven gear wheel 6, is of considerably larger diameter than the driving gear wheel 5. As explained in relation to Figure 3, if both gear wheels were fed separately through respective nips, both would transport the same amount of medium regardless of their diameters, as their speeds of rotation are inversely proportional to the diameter. However the larger, more slowly rotating gear wheel provides a proportionally longer residence time for the medium, which thus will be more exposed to heat transfer through the casing 2, shown with passages 13. At the outlet 10, which is a conical passage extending along the gear wheels 5, 6, the two streams of medium arriving would be at considerably different temperatures, which can be a problem for some types of medium. To avoid this, the small gear wheel 5 has no feed inlet at all. The larger gear wheel 6 then acts as a heat exchanger, and can be arranged to provide the correct amount of heat for the medium. It is also possible for the larger gear wheel 6 to be the driving gear and the smaller gear wheel 5 the driven gear, if appropriate for the mechanical design.

Entrained air will be expelled through the smaller gear wheel 5 which is not being fed, into the feed inlet 4, as the medium is compressed at the meshing region of the gear wheels. The outlet 10 conveys the medium, as in Figures 1 and 2, to an extruder section of the Transfermix type. The arrangement of the outlet 10 and the channels 11 is similar to that of Figure 1.

The extruder section then imparts to the prewarmed medium whatever amount of mechanical working it can still absorb according to its viscosity.

Owing to the large diameter and width of the gear and by way of setting the temperature of the heating medium, it will be possible to vary the temperature of the medium coming into the extruder to suit its viscosity and flow-characteristics to such a level that the mechanical work-input will neither be insufficient nor excessive by any significant amount. This can especially be achieved with a Transfermix geometry which, with appropriate design, will uniformly impart mechanical work to all of the medium even when the speed of rotation of the screw is slow compared to extruders not fed by a gear pump. It is known that in such extruders a large proportion of the mechanical work-input is imparted in uncontrolled circulation with much friction in the region of the feed opening and of the compression zone. This is on account of this region having to provide much of the pressure-build-up for the pumping action with as high a speed of rotation of the screw as the medium can stand without an excessive extrusion temperature. This situation requires greater lengths of screw and wastes energy in cooling and radiation, as is shown up in the comparison between extruders and gear pumps referred to below.

The energy-economy of the gear pump even when building up high pressures is combined with the known advantages of the Transfermix. These have hitherto been limited by the Transfermix screw also having to provide for the transport of the medium and therefore being rotated much faster than the amount of mechanical work-input for effective plastification at the lowest extrusion-temperature suited to the medium would require.

When of small diameters, properly designed Transfermix cold feed extruders efficiently and uniformly plasticize very nery and/or highly filled elastomers at very good outputs for the size when being considerably throttled in order to achieve the required quality of

extrusion. For larger diameters, the increased pressure-back-flow in the deeper screw-channels gave rise to low outputs for the size, which made them uneconomic, although being still better than cold feed extruders with other plasticizing systems. It is particularly this limitation which this invention overcomes.

It will be understood that the gear wheels forming the pump may have their teeth parallel to their axes, or may have these skewed in one way or arrow-fashion to promote self-cleaning and a smoother pumping action. Also, portions of the housing may be openable for ease of cleaning when the compound is changed.

Moreover, in an embodiment such as Figures 4 and 5, both the larger and the smaller gear wheels may be driven directly by appropriate shafts extending from a mechanical gearbox having the same size gear wheels for the mechanical force-transfer. In such a system, actually mechanically redundant, the oil-lubricated gears in the gearbox will be designed to override the forces in the gear pump.

Further, it will be appreciated that while the gear wheels in the embodiments shown are mounted on parallel axes, it would be possible for the axis of the non-co-axial gear wheel to be inclined to the axis of the co-axial gear wheel.

The diameters of the gear pump wheels, in the present example having an equal outside diameter to that of the screw, may be both larger or smaller than the nominal screw diameter, to suit space, transport or heat-exchange considerations. A gear pump is very flexible in that, all other parameters being fixed by such considerations, its length can always be made such as to provide the required output per revolution.

In "Tire Technology 1997" pp197-198, 'Screw- or Gear Extruder - a Comparative Study', the latter are shown to be efficient at plasticizing by heat-transfer through the casing, providing about 50% of the energy in the plasticized compound in that way. In the example, the modulus of the gear wheels would be about 5 mm, so that the depth of the teeth is about 10 mm. As the heat-transfer applies to the discrete, non-flowing elements contained between the teeth of the gear pump which in their interior can only be considerably less affected by heat transfer through the wall, this must apply to uses where, as in straining or calandering, the following device as part of its function incidentally operates towards improving temperature-uniformity. It is also a fact that all types of rubber-compound are just about equally bad conductors of heat. However, being this efficient at heating, the gear pump will be equally efficient at cooling when the compound fed into it is already hot, as in the examples of this invention. In these, the passages feeding the compound back into the screw which are essentially Transfermix sections, can be designed to provide homogeneity of temperature in the extrudate.

Figure 6 shows a cold feed extruder of the Transfermix type, with a gear pump following a plasticizing section. The barrel 21 of the Transfermix is fed from a chute 22 leading into an inlet section 23, which in this example also has a conventional feed-roll 24 in its housing, openable on a vertical hinge, indicated on the right. In fact, Figure 6 is an example of a Transfermix as presently built, converted to an integrated gear pump extruder. The extruder screw, of which only a rotary union 27 at the end of its shaft is visible, is driven by a motor 26 through a reduction gear 25. The gear pump has its driven wheel fixed onto the screw shaft following the plasticizing Transfermix section and its driven gear underneath. A housing 28 contains both the pump itself and the transition

sections into and out of it. Immediately adjacent the plasticizing
Transfermix barrel there is an adjustable throttle 29.

5 A part 30 of the housing, hinged on a horizontal axis, provides access to
the gear pump as well as to the inlet and outlet sections thereof. The
hinged part 30 is similar in basic concept to the feed-roll 24 in its hinged
housing. A short outlet section 31 of the extruder screw in a cylindrical
barrel leads to an extrusion head 32.

10 Figure 7 is similar to Figure 6, with like numerals denoting like parts. In
Figure 7 the gear wheel which is co-axial with the extruder screw is
mounted rotatably relative thereto on the screw shaft. In this example, the
secondary gear wheel is separately driven by a motor 33, so that the co-
axial gear wheel can rotate independently of the screw. The motor will be
15 of low power compared to the main drive motor, as the gear pump only
has to work on already plasticized compound and only has to provide any
necessary pressure-build-up. According to the literature on gear pumps,
very little power is required for this purpose even over a wide range of
speeds and pressures to be built up, even to the high pressures needed for
20 screening a rubber compound.

Such an arrangement may well serve special process requirements or may
be used for test purposes to determine what design of gear pump (pitch
and/or length) may suit a given Transfermix geometry over the required
25 range of compounds, also taking into account the action of the throttle in
widening this range.

If the Transfermix geometry, the throttle and the gear pump are well
mated, with the gear pump removing a major part of the back-pressure on
30 the extruder, its inlet section may well be redesigned so as to make a

feed-roll superfluous. Under such conditions, an embodiment such as that of Figure 6, with its driving gear of one piece with the screw, will basically be no more complicated than a conventional extruder with its feed-roll driven directly from the screw shaft by means of gears. The difference is, however, that the feed-roll and its drive gears will have to be of more robust design than the gear pump, because the action in the inlet is on unplasticized rubber whereas the gear pump acts on plasticized rubber only.

The throttle 29 will have to be capable of a high degree of closure and may be needed especially during start-up in order to prevent unplasticized rubber entering the gear pump. In steady-state operation, the throttle will only need to be partially or not closed at all if the Transfermix section is designed for a high degree of plasticization. The approach to these conditions may be more easily explored with the embodiment of Figure 7, so that no feed-roll is shown here.

Figure 8, the cross-section on line B - B of Figure 6 or Figure 7, shows the helical grooves of the Transfermix barrel sleeve 36 at full depth co-acting with the screw 35 as a round bar, its opposite handed helical grooves having reduced to zero depth. The concentric tempering ducts 37 and 38 emerging from the rotary union 27 are indicated in the central bore. At this section the compound flows in the helical grooves 39 of the barrel sleeve 36 which is non-rotatably held in the barrel 21 by its hexagonal end flange. The barrel housing 21 forward of this end flange is provided with the usual ducts for a tempering fluid.

Figure 9, the cross-section on line D - D through the gears of the pump, shows the driving gear wheel 40 mounted to be as of one piece with the screw, as described for Figure 6, and of an outside diameter equal to that

of the screw to enable these parts to be removed as one component for disassembly, as in normal extruder practice. The driven gear wheel 41 is of substantially equal dimensions and is mounted in the hinged component 30 of the housing 28. The hinge is positioned such that gear wheel 41 can
5 disengage from gear wheel 40 upon the housing being opened. A mechanism for positioning the component 30 may well be fitted, but is not shown.

The gear teeth 42 and 43 are only indicated by way of concentric circles,
10 being in this example of a small modulus and hence of small depth in order to effect a subdivision of the compound into small elements suited for effective heat-exchange with both the gear wheels and the housing 28. As stated before, the power drawn by the gear pump is comparatively small as long as provision is made that only plasticized compound is
15 introduced into the gear pump so that such a basically weaker design of gears facilitating heat-exchange can be used within calculated limits.

The inlet duct 44 of the gear pump, at this section some way along the length of the gear pump, carries a part of the flow of compound which has
20 emerged from the barrel grooves 39, as the flow-cross-section of this duct decreases from full to zero along the length of the pump. The divider 45 performs a similar action as the divider 7 in Figure 2 or 17 in Figure 3.

Conversely, the outlet duct 46 (shown in dotted lines) of the gear pump
25 increases from zero to full flow-cross-section along the length of the gear pump. Following this, the transition section into the outlet section 31 of the extruder screw will be shaped similarly to section 12 of Figure 1, as a Transfermix section designed for minimum work input but effecting homogenisation of the temperature of the elements emerging from the gear
30 pump. The housing 28 is provided with ducts 48 for a tempering fluid.

Figure 10 is a part-cross-section on line C - C of Figure 6 showing a throttle, in this example, consisting of a fixed ring and an adjacent ring capable of relative rotary adjustment, each having sets of radial internal
5 vanes 50 and 51 mounted after the end of the Transfermix barrel, next to the end plane of the Transfermix sleeve shown in Figure 8. Here the vanes are shown to be superimposed, that is, the throttle is in the open position.

10 Figure 11 is a part-cross-section on line C - C of Figure 6 showing the vanes 50 and 51 out of alignment after a corresponding rotary adjustment of the movable ring, so that the throttle 29 is almost closed. The moving mechanism of this throttle is known in the art, and is not shown here.

15 It must be noted that different types of throttle can be used here. Another example known in the art would be radial pins each of only slightly smaller width than the grooves shown in Figure 6 and capable of being moved radially inwards to almost close these grooves and when withdrawn into the barrel sleeve being flush with the bottoms of these grooves to
20 permit a complete opening of the flow.

Following such a throttle, the housing provides a duct 46, as indicated in dotted lines, which starts with a substantially annular shape after the throttle, then narrows in the circumferential sense while winding around
25 the screw shaft in the same sense as the grooves in the barrel and finishes up concentrating the flow of the medium at the full flow cross-section, also indicated in dotted lines, of the inlet duct 44 of the gear pump. By this means transport into the pump is helped by the relative rotation of the screw shaft exerting drag-flow on the medium.

CLAIMS

1. A single rotor extruder for an elastomeric plastics medium having a casing (2) in which an extruder screw (1) works and including a gear
5 pump comprising a casing and at least two gear wheels (5, 6), the gear pump casing being integral with the casing (2) of the extruder, and one gearwheel (5) of the gear pump being coaxial with the extruder screw (1), characterised in that the extruder (1) has a Transfermix section (12) formed where the extruder screw (1) has a part with a external helical
10 thread working in a barrel part of the casing with an internal helical thread (11) of opposite hand but coaxial with the external thread, the helical threads facing each other to define a passage for the medium, and the cross-sectional areas of the grooves of the threads varying in opposite senses between a maximum value and a minimum value along the same
15 length of the passage, the gear pump being located adjacent the Transfermix section (12).
2. A single rotor extruder as claimed in claim 1, in which an outlet
20 (10) from the gear pump leads to an inlet of the extruder Transfermix section.
3. A single rotor extruder as claimed in claim 1, in which an outlet from the extruder Transfermix section leads to an inlet of the gear pump.
- 25 4. A single rotor extruder as claimed in any preceding claim, in which the coaxial gearwheel (5) and a shaft of the extruder screw (1) are connected fixedly to rotate together.
5. A single rotor extruder as claimed in any of claims 1 to 3, in which
30 the coaxial gearwheel (5) and a shaft of the extruder screw (1) are

mounted to be independently rotatable, and the other gearwheel (6) of the gear pump has a separate drive to provide for the coaxial gearwheel (5) a rotational speed different from that of the extruder screw.

5 6. A single rotor extruder as claimed in any of claims 1 to 3, in which the coaxial gearwheel (5) and a shaft of the extruder screw (1) are connected by a transmission which provides for a step-wise or continuously variable ratio between the rotational speed of the gearwheel and that of the extruder screw.

10

7. A single rotor extruder as claimed in any preceding claim, in which the gear pump casing has an outlet passage (10) at the outlet high pressure side of the gear pump starting at substantially zero at one end of the gear pump and increasing progressively until at the other end of the gear pump
15 it has a cross-section for full flow of the medium.

8. A single rotor extruder as claimed in claim 2 and claim 7, in which the outlet passage continues as a feed passage (11) in the extruder casing (2), open towards the screw (1) over an initial feed length with a
20 cross-section continuously decreasing to zero to feed the medium into the extruder screw.

9. A single rotor extruder as claimed in claim 8, in which the feed passage (11) is in the shape of a spiral of opposite hand to that of the
25 extruder screw, and over the feed length of the feed passage (11) the cross-sectional area of the screw increases from an initial zero cross-section to a full cross-section.

10. A single rotor extruder as claimed in claim 8 or claim 9, in which the feed passage (11) winds around the extruder screw in the opposite hand to the screw as it reduces in cross-sectional area from full to zero.
- 5 11. A single rotor extruder as claimed in claim 2 or claim 2 and any of claims 4 to 10, in which the gear pump is arranged at the feed inlet of the extruder, the gear pump having a feed inlet (4) for feeding sheet, strip or pellets of medium into a single intake nip between one gearwheel (6) and the casing wall.
- 10 12. A single rotor extruder as claimed in claim 11, in which the gearwheel (6) defining the single intake nip is of larger diameter than the other gearwheel (5) of the gear pump.
- 15 13. A single rotor extruder as claimed in claim 2 or claim 2 and any of claims 4 to 10, used as a dump extruder-mixer, in which the extruder has a substantially rectangular drop opening (16) and the feed side of the gear pump forms the inlet of the dump extruder, an outlet from an internal mixer and the extruder inlet being connected by a drop chute (18), the
20 length of the gearwheels being chosen to accommodate the depth of the drop chute, and pump means, gland means and a vacuum pump being provided to enable the drop chute to be operated under vacuum.
- 25 14. A single rotor extruder as claimed in claim 13, in which one gearwheel (15) of the gear pump is of substantially larger diameter than the extruder screw for the total width of the gear pump inlet, to accommodate the width of the drop chute (18).

15. A single rotor extruder as claimed in claim 13 or claim 14, in which at least one of the gear wheels (5,6) is enlarged in diameter and/or length.
- 5 16. A single rotor extruder as claimed in any of claims 13 to 15, in which the gear wheels have a small modulus to enhance their cooling capacity.
- 10 17. A single rotor extruder as claimed in claim 3 and any of claims 4 to 7, in which the Transfermix section plasticizes the medium, and the extruder has a transition section between the outlet of the Transfermix section and the gear pump inlet, the extruder casing at the transition section being shaped to conduct medium to the inlet side of the gear pump in a passage which is partly shaped to wind round the extruder screw shaft
15 in the same hand as the barrel grooves whereby rotation of the screw contributes to the forward transport of the medium for a substantial part of the length of the transition section to the gear pump inlet.

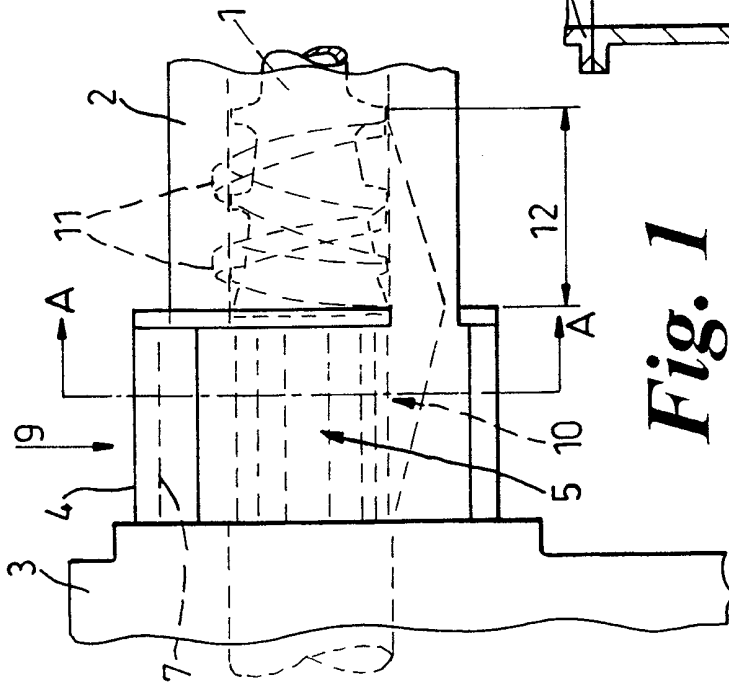

Fig. 1

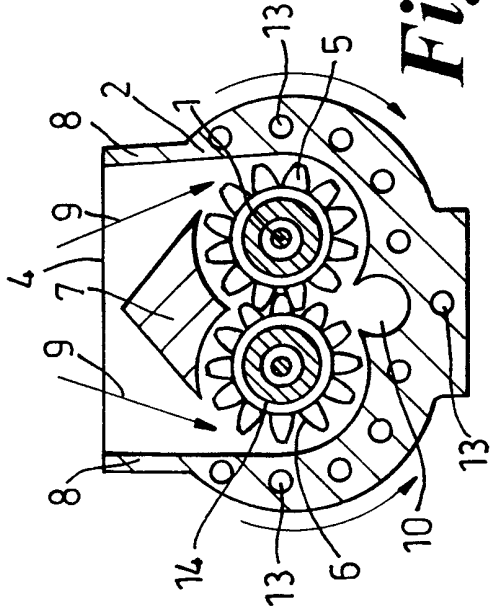

Fig. 2

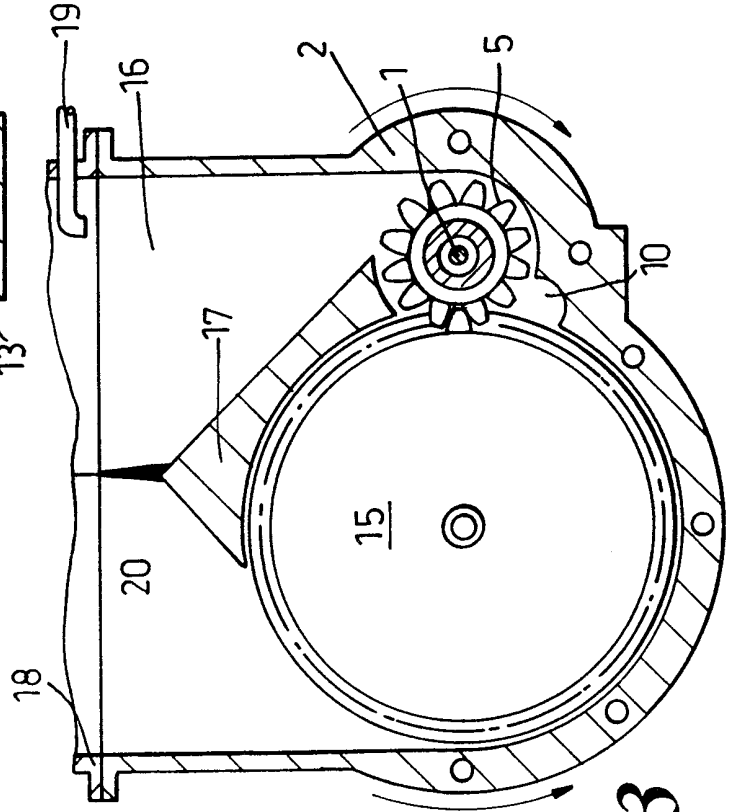

Fig. 3

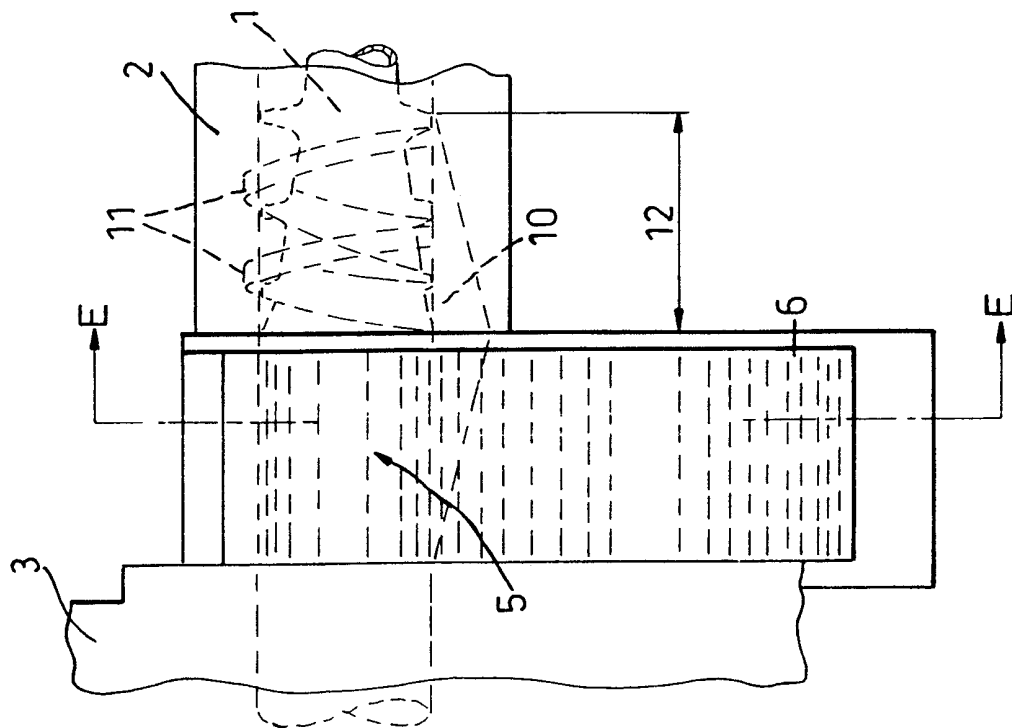

Fig. 4

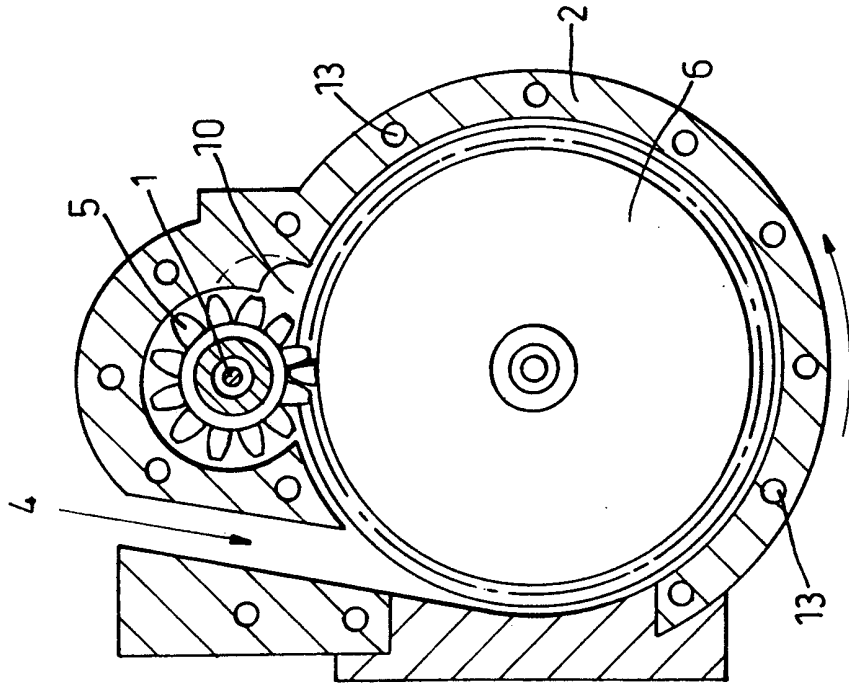

Fig. 5

3/4

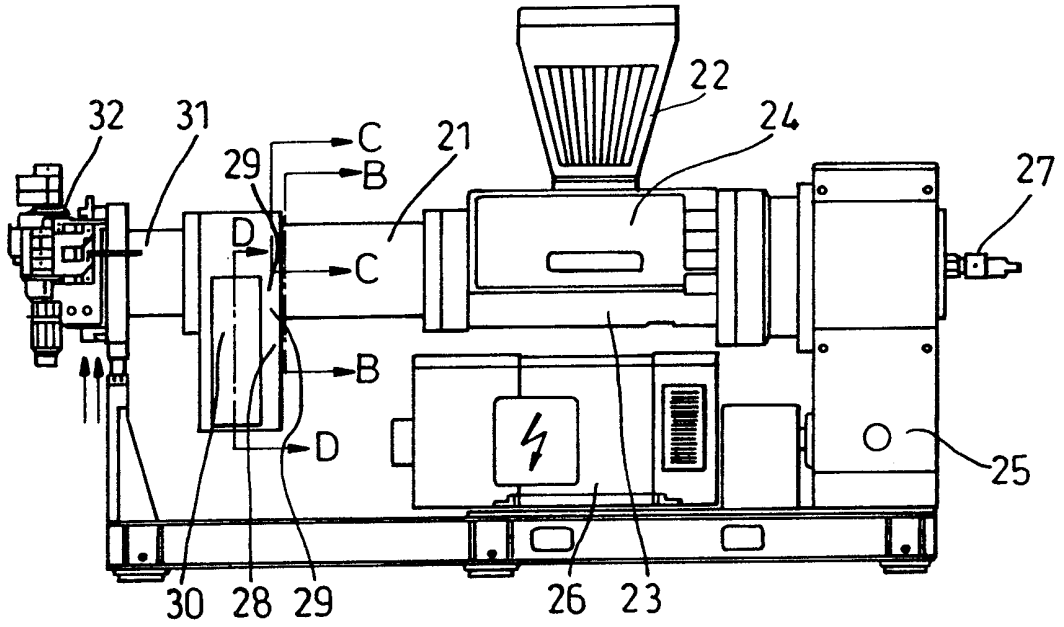

Fig. 6

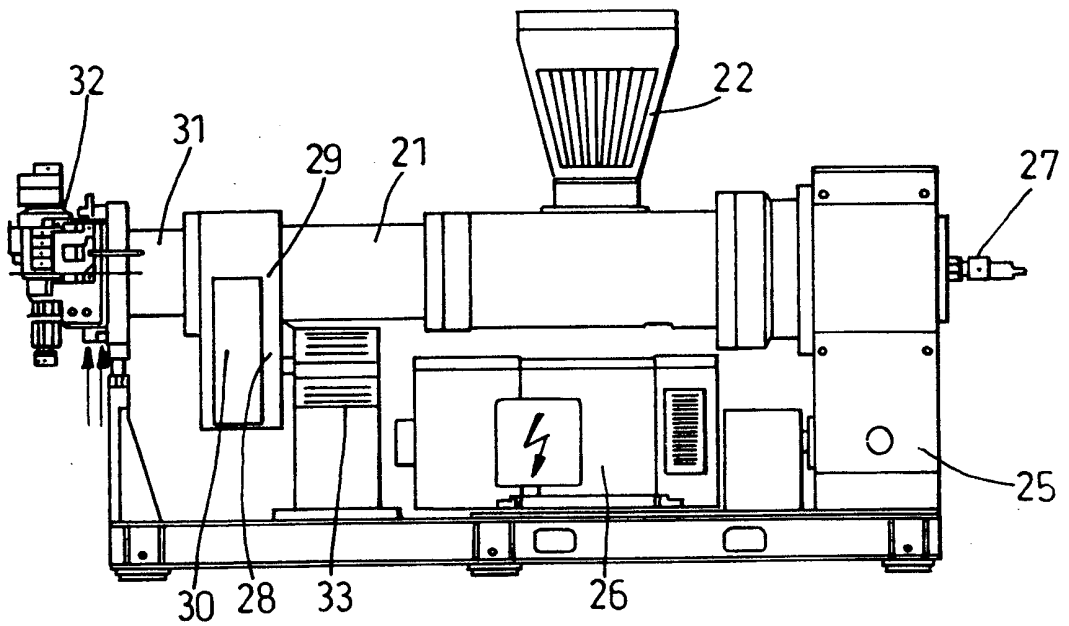

Fig. 7

Fig. 11

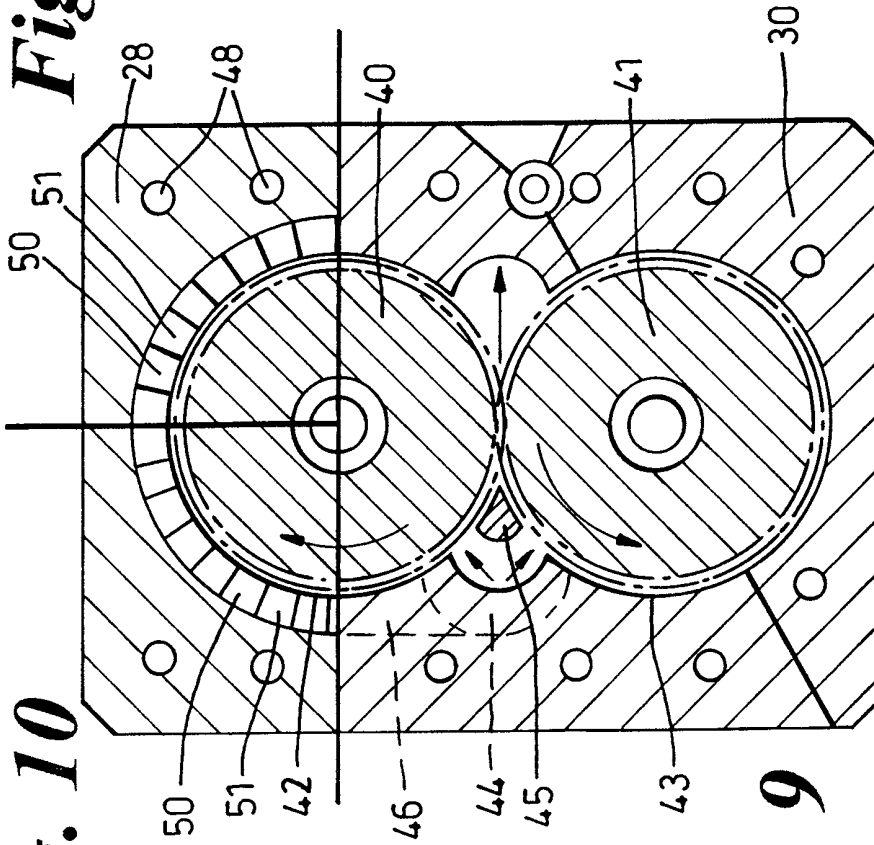

Fig. 10

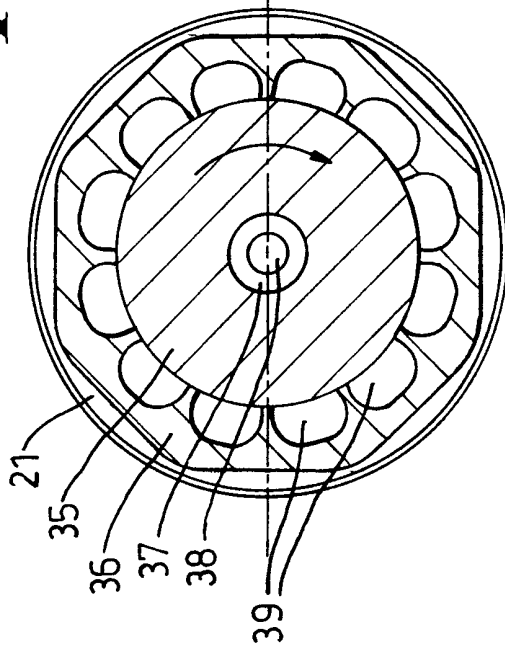

Fig. 8

Fig. 9

INTERNATIONAL SEARCH REPORT

International Application No PCT/GB 00/00899

A. CLASSIFICATION OF SUBJECT MATTER
 IPC 7 B29C47/50 B29C47/58 B29C47/10 B29C47/38

According to International Patent Classification (IPC) or to both national classification and IPC

B. FIELDS SEARCHED

Minimum documentation searched (classification system followed by classification symbols)
 IPC 7 B29C

Documentation searched other than minimum documentation to the extent that such documents are included in the fields searched

Electronic data base consulted during the international search (name of data base and, where practical, search terms used)
 PAJ, WPI Data, EPO-Internal

C. DOCUMENTS CONSIDERED TO BE RELEVANT

Category °	Citation of document, with indication, where appropriate, of the relevant passages	Relevant to claim No.
Y	US 4 642 040 A (FOX STEVE A) 10 February 1987 (1987-02-10) the whole document ---	1-6
Y	EP 0 492 425 A (BRIDGESTONE CORP) 1 July 1992 (1992-07-01) column 8, line 28 - line 34 column 12, line 3 - line 27 claims; figures ---	1-6
A	---	7-17
A	EP 0 642 913 A (BAYER AG) 15 March 1995 (1995-03-15) cited in the application column 2, line 21 - line 41 column 4, line 48 - line 54 claims; figures 1-3 ---	1-4,7,8, 17
	-/--	

Further documents are listed in the continuation of box C. Patent family members are listed in annex.

° Special categories of cited documents :

"A" document defining the general state of the art which is not considered to be of particular relevance "E" earlier document but published on or after the international filing date "L" document which may throw doubts on priority claim(s) or which is cited to establish the publication date of another citation or other special reason (as specified) "O" document referring to an oral disclosure, use, exhibition or other means "P" document published prior to the international filing date but later than the priority date claimed	"T" later document published after the international filing date or priority date and not in conflict with the application but cited to understand the principle or theory underlying the invention "X" document of particular relevance; the claimed invention cannot be considered novel or cannot be considered to involve an inventive step when the document is taken alone "Y" document of particular relevance; the claimed invention cannot be considered to involve an inventive step when the document is combined with one or more other such documents, such combination being obvious to a person skilled in the art. "&" document member of the same patent family
---	---

Date of the actual completion of the international search 29 June 2000	Date of mailing of the international search report 05/07/2000
--	---

Name and mailing address of the ISA European Patent Office, P.B. 5818 Patentlaan 2 NL - 2280 HV Rijswijk Tel. (+31-70) 340-2040, Tx. 31 651 epo nl, Fax: (+31-70) 340-3016	Authorized officer Jensen, K
--	--

INTERNATIONAL SEARCH REPORT

Inter. Application No
PCT/GB 00/00899

C.(Continuation) DOCUMENTS CONSIDERED TO BE RELEVANT		
Category °	Citation of document, with indication, where appropriate, of the relevant passages	Relevant to claim No.
A	DE 12 16 478 B (ALGEMENE KUNSTZIJDE UNIE N.V.) the whole document ---	1,3-5
A	WO 98 09792 A (LIMPER ANDREAS) 12 March 1998 (1998-03-12) figures 1,3,5 ---	7-11
A	US 1 516 968 A (E. H. JOHNSON) 25 November 1924 (1924-11-25) figures ---	1,3,4
A	US 5 310 256 A (BODEN HELLMUT) 10 May 1994 (1994-05-10) figures ---	1,3,5
A	US 5 304 053 A (GOHLISCH HANS-JOACHIM ET AL) 19 April 1994 (1994-04-19) column 3, line 11 - line 15 figures -----	12-15

INTERNATIONAL SEARCH REPORT

information on patent family members

International Application No

PCT/GB 00/00899

Patent document cited in search report		Publication date	Patent family member(s)	Publication date
US 4642040	A	10-02-1987	NONE	
EP 0492425	A	01-07-1992	US 5156781 A DE 69124788 D DE 69124788 T ES 2098308 T JP 5116200 A US 5267847 A	20-10-1992 03-04-1997 12-06-1997 01-05-1997 14-05-1993 07-12-1993
EP 0642913	A	15-03-1995	DE 4331109 A DE 59406660 D	16-03-1995 17-09-1998
DE 1216478	B		NONE	
WO 9809792	A	12-03-1998	DE 19635706 A EP 0925167 A	05-03-1998 30-06-1999
US 1516968	A	25-11-1924	NONE	
US 5310256	A	10-05-1994	DE 4126390 A DE 59201084 D EP 0528107 A JP 5192924 A	11-02-1993 09-02-1995 24-02-1993 03-08-1993
US 5304053	A	19-04-1994	DE 4115246 C DE 59204170 D EP 0513593 A ES 2082267 T JP 5154891 A	14-05-1992 07-12-1995 19-11-1992 16-03-1996 22-06-1993