

(12) INTERNATIONAL APPLICATION PUBLISHED UNDER THE PATENT COOPERATION TREATY (PCT)

(19) World Intellectual Property Organization
International Bureau



(43) International Publication Date
14 December 2000 (14.12.2000)

PCT

(10) International Publication Number
WO 00/74600 A1

(51) International Patent Classification⁷: A61F 2/14

(21) International Application Number: PCT/US00/15691

(22) International Filing Date: 7 June 2000 (07.06.2000)

(25) Filing Language: English

(26) Publication Language: English

(30) Priority Data:
60/138,105 7 June 1999 (07.06.1999) US

(71) Applicant and

(72) Inventor: SCHACHAR, Ronald, A. [US/US]; 10010
Lennox Lane, Dallas, TX 75229 (US).

(74) Agents: MUNCK, William, A. et al.; Novakov Davis,
P.C., 2000 St. Paul Place, 750 North St. Paul Street, Dallas,
TX 75201-3286 (US).

(81) Designated States (national): AE, AG, AL, AM, AT, AU,
AZ, BA, BB, BG, BR, BY, CA, CH, CN, CR, CU, CZ, DE,

DK, DM, DZ, EE, ES, FI, GB, GD, GE, GH, GM, HR, HU,
ID, IL, IN, IS, JP, KE, KG, KP, KR, KZ, LC, LK, LR, LS,
LT, LU, LV, MA, MD, MG, MK, MN, MW, MX, NO, NZ,
PL, PT, RO, RU, SD, SE, SG, SI, SK, SL, TJ, TM, TR, TT,
TZ, UA, UG, UZ, VN, YU, ZA, ZW.

(84) Designated States (regional): ARIPO patent (GH, GM,
KE, LS, MW, MZ, SD, SL, SZ, TZ, UG, ZW), Eurasian
patent (AM, AZ, BY, KG, KZ, MD, RU, TJ, TM), European
patent (AT, BE, CH, CY, DE, DK, ES, FI, FR, GB, GR, IE,
IT, LU, MC, NL, PT, SE), OAPI patent (BF, BJ, CF, CG,
CI, CM, GA, GN, GW, ML, MR, NE, SN, TD, TG).

Published:

- With international search report.
- Before the expiration of the time limit for amending the claims and to be republished in the event of receipt of amendments.

For two-letter codes and other abbreviations, refer to the "Guidance Notes on Codes and Abbreviations" appearing at the beginning of each regular issue of the PCT Gazette.

(54) Title: IMPROVED SCLERAL PROSTHESIS FOR TREATMENT OF PRESBYOPIA AND OTHER EYE DISORDERS

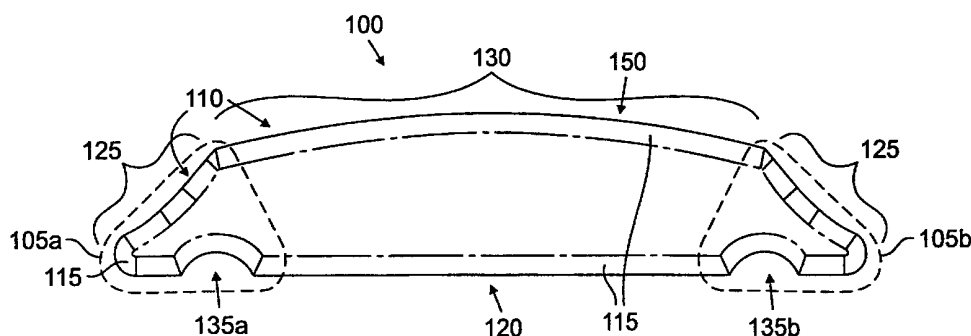

(57) Abstract: Presbyopia and other eye disorders are treated by implanting within a plurality of elongated pockets formed in the tissue of the sclera of the eye transverse to a meridian of the eye, a prosthesis having an elongated base member having an inward surface adapted to be placed against the inward wall of the pocket and having a ridge on the inward surface of the base extending along at least a major portion of the major dimension of the base. The combined effect of the implanted prostheses is to exert a radially outward traction of the sclera in the region overlying the ciliary body which expands the sclera in the affected region together with the underlying ciliary body. The expansion of the ciliary body restores the effective working distance of the ciliary muscle in the presbyopic eye and thereby increases the amplitude of accommodation. Introduced is an improved scleral prosthesis for the treatment of presbyopia and other eye disorders. An exemplary prosthesis is adapted for contact with the sclera of an eyeball, and comprises a body having a first end and a second end wherein the body has (i) a planform adapted to expand the contacted sclera to increase the effective working distance of the ciliary muscle of the eyeball, and (ii) means for stabilizing the prosthesis within the surgically formed pocket within the sclera of the eyeball.

WO 00/74600 A1

IMPROVED SCLERAL PROSTHESIS FOR TREATMENT OF
PRESBYOPIA AND OTHER EYE DISORDERS

5 CROSS REFERENCE TO RELATED APPLICATIONS

The present invention is related to that disclosed in
(1) United States Patent Application Serial No. 08/946,975
entitled "SCLERAL PROSTHESIS FOR TREATMENT OF PRESBYOPIA
AND OTHER EYE DISORDERS," filed October 8, 1997, now United
10 States Patent No. 6,007,578 issued December 28, 1999 (the
"'975 Application"); (2) United States Patent Application
Serial No. 09/061,168 entitled "SCLERAL PROSTHESIS FOR
TREATMENT OF PRESBYOPIA AND OTHER EYE DISORDERS," filed on
April 16, 1998 (a Continuation-in-Part Patent Application
15 of the '975 Application); (3) United States Patent
Application Serial No. 09/472,535 entitled "SCLERAL
PROSTHESIS FOR TREATMENT OF PRESBYOPIA AND OTHER EYE
DISORDERS," filed December 27, 1999 (a Continuation Patent
Application of the '975 Application); and (4) United States
20 Provisional Application No. 60/138,105 entitled "IMPROVED
SCLERAL PROSTHESIS FOR TREATMENT OF PRESBYOPIA AND OTHER
EYE DISORDERS," filed June 7, 1999 (the specification of
the present invention claims priority to this provisional
application under 35 U.S.C. §119(e)(1)). All four patent
25 documents, and the inventions disclosed therein, are
commonly assigned to the assignee of the present invention,
share common inventorship, and are incorporated herein by
reference for all purposes as if fully set forth herein.

TECHNICAL FIELD OF THE INVENTION

This invention relates to methods of treating presbyopia, hyperopia, primary open angle glaucoma and ocular hypertension and more particularly to methods of treating these diseases by increasing the effective working distance of the ciliary muscle. The invention also relates to increasing the amplitude of accommodation of the eye by increasing the effective working range of the ciliary muscle.

BACKGROUND OF THE INVENTION

In order for the human eye to have clear vision of objects at different distances, the effective focal length of the eye must be adjusted to keep the image of the object focused as sharply as possible on the retina. This change in effective focal length is known as accommodation and is accomplished in the eye by varying the shape of the crystalline lens. Generally, in the unaccommodated emmetropic eye the curvature of the lens is such that distant objects are sharply imaged on the retina. In the unaccommodated eye near objects are not focused sharply on the retina because their images lie behind the retinal surface. In order to visualize a near object clearly, the curvature of the crystalline lens is increased, thereby increasing its refractive power and causing the image of the near object to fall on the retina.

The change in shape of the crystalline lens is accomplished by the action of certain muscles and structures within the eyeball or globe of the eye. The lens is located in the forward part of the eye, immediately behind the pupil. It has the shape of a classical biconvex optical lens, i.e., it has a generally circular cross

-3-

section having two convex refracting surfaces, and is located generally on the optical axis of the eye, i.e., a straight line drawn from the center of the cornea to the macula in the retina at the posterior portion of the globe.

5 In the unaccommodated human eye the curvature of the posterior surface of the lens, i.e., the surface adjacent to the vitreous body, is somewhat greater than that of the anterior surface. The lens is closely surrounded by a membranous capsule that serves as an intermediate structure

10 in the support and actuation of the lens. The lens and its capsule are suspended on the optical axis behind the pupil by a circular assembly of very many radially directed elastic fibers, the zonules, which are attached at their inner ends to the lens capsule and at their outer ends to

15 the ciliary muscle, a muscular ring of tissue, located just within the outer supporting structure of the eye, the sclera. The ciliary muscle is relaxed in the unaccommodated eye and therefore assumes its largest diameter. According to the classical theory of

20 accommodation, originating with Helmholtz, the relatively large diameter of the ciliary muscle in this condition causes a tension on the zonules which in turn pulls radially outward on the lens capsule, causing the equatorial diameter of the lens to increase slightly and decreasing the anterior-posterior dimension of the lens at

25 the optical axis. Thus, the tension on the lens capsule causes the lens to assume a flattened state wherein the curvature of the anterior surface, and to some extent the posterior surface, is less than it would be in the absence

30 of the tension. In this state the refractive power of the lens is relatively low and the eye is focused for clear vision for distant objects.

-4-

When the eye is intended to be focused on a near object, the ciliary muscles contract. According to the classical theory, this contraction causes the ciliary muscle to move forward and inward, thereby relaxing the outward pull of the zonules on the equator of the lens capsule. This reduced zonular tension allows the elastic capsule of the lens to contract causing an increase in the antero-posterior diameter of the lens (i.e., the lens becomes more spherical) resulting in an increase in the optical power of the lens. Because of topographical differences in the thickness of the lens capsule, the central anterior radius of curvature decreases more than the central posterior radius of curvature. This is the accommodated condition of the eye wherein the image of near objects falls sharply on the retina.

Presbyopia is the universal decrease in the amplitude of accommodation that is typically observed in individuals over 40 years of age. In the person having normal vision, i.e., having emmetropic eyes, the ability to focus on near objects is gradually lost, and the individual comes to need glasses for tasks requiring near vision, such as reading.

According to the conventional view the amplitude of accommodation of the aging eye is decreased because of the loss of elasticity of the lens capsule and/or sclerosis of the lens with age. Consequently, even though the radial tension on the zonules is relaxed by contraction of the ciliary muscles, the lens does not assume a greater curvature. According to the conventional view, it is not possible by any treatment to restore the accommodative power to the presbyopic eye. The loss of elasticity of the lens and capsule is seen as irreversible, and the only solution to the problems presented by presbyopia is to use

-5-

corrective lenses for close work, or bifocal lenses, if corrective lenses are also required for distant vision.

Certain rings and/or segments have been used in ocular surgery for various purposes. Rings and/or segments of flexible and/or elastic material, attached or prepared in situ by fastening the ends of strips of the material around the posterior portion of the globe, posterior to the pars plana (over the underlying retina), have been used to compress the sclera in certain posterior regions. Supporting rings of metal, adapted to fit the contour of the sclera have been used as temporary supporting structures during surgery on the globe. However, none of these known devices have been used for surgical treatment of presbyopia, and none have been adapted to the special needs of prosthetic devices used in treating presbyopia.

Accordingly, a need has continued to exist for a method of treating presbyopia that will increase the amplitude of accommodation of the presbyopic eye, thereby lessening or eliminating the need for auxiliary spectacle lenses to relieve the problems of presbyopia.

SUMMARY OF THE INVENTION

5 Presbyopia and other eye disorders are treated by
implanting within a plurality of elongated pockets formed
in the tissue of the sclera of the eye transverse to a
meridian of the eye, a prosthesis having an elongated base
member having an inward surface adapted to be placed
against the inward wall of the pocket and having a ridge on
the inward surface of the base extending along at least a
major portion of the major dimension of the base. The
10 combined effect of the implanted prostheses is to exert a
radially outward traction on the sclera in the region
overlying the ciliary body which expands the sclera in the
affected region together with the underlying ciliary body.
The expansion of the ciliary body restores the effective
15 working distance of the ciliary muscle in the presbyopic
eye and thereby increases the amplitude of accommodation.
Introduced is an improved scleral prosthesis for the
treatment of presbyopia and other eye disorders. An
exemplary prosthesis in accordance with the teachings
20 hereof is adapted for contact with the sclera of an
eyeball, and comprises a body having a first end and a
second end wherein the body has (i) a planform adapted to
expand the contacted sclera to increase the effective
working distance of the ciliary muscle of the eyeball, and
25 (ii) means for stabilizing the prosthesis within the
surgically formed pocket within the sclera of the eyeball.

The foregoing has outlined rather broadly the features
and technical advantages of the present invention so that
those skilled in the art may better understand the detailed
30 description of the invention that follows. Additional
features and advantages of the invention will be described
hereinafter that form the subject of the claims of the

-7-

invention. Those skilled in the art should appreciate that they may readily use the conception and the specific embodiment disclosed as a basis for modifying or designing other structures for carrying out the same purposes of the present invention. Those skilled in the art should also realize that such equivalent constructions do not depart from the spirit and scope of the invention in its broadest form.

BRIEF DESCRIPTION OF THE DRAWINGS

An advantageous embodiment of the present invention may be understood with reference to the following descriptions taken in conjunction with the accompanying drawings, wherein like numbers designate like objects, in which:

FIGURE 1 illustrates a top plan view of an advantageous embodiment of an improved scleral prosthesis in accordance with the principles of the present invention;

FIGURE 2 illustrates a side elevational view of the embodiment of the scleral prosthesis of FIGURE 1;

FIGURE 3 illustrates a bottom plan view of the embodiment of the scleral prosthesis of FIGURES 1 and 2;

FIGURE 4 illustrates a top-side isometric view of the embodiment of the scleral prosthesis of FIGURES 1 to 3;

FIGURE 5 illustrates a top plan view of one end of the embodiment of the scleral prosthesis of FIGURES 1 to 4; and

FIGURE 6 illustrates a bottom-side isometric view of the embodiment of the scleral prosthesis of FIGURES 1 to 5.

DETAILED DESCRIPTION OF THE INVENTION

The principles of the present invention introduce and teach improvements upon the scleral prosthesis introduced and taught in United States Patent Application Serial No. 08/946,975 entitled "SCLERAL PROSTHESIS FOR TREATMENT OF PRESBYOPIA AND OTHER EYE DISORDERS," filed October 8, 1997 (the "'975 Application"); United States Patent Application Serial No. 09/061,168 entitled "SCLERAL PROSTHESIS FOR TREATMENT OF PRESBYOPIA AND OTHER EYE DISORDERS," filed on April 16, 1998 (a Continuation-in-Part Patent Application of the '975 Application); United States Patent Application Serial No. 09/472,535 entitled "SCLERAL PROSTHESIS FOR TREATMENT OF PRESBYOPIA AND OTHER EYE DISORDERS," filed December 27, 1999 (a Continuation Patent Application of the '975 Application); and United States Provisional Application No. 60/138,105 entitled "IMPROVED SCLERAL PROSTHESIS FOR TREATMENT OF PRESBYOPIA AND OTHER EYE DISORDERS," filed June 7, 1999 (the specification of the present invention claims priority to this provisional application under 35 U.S.C. §119(e)(1)). All four patent documents, and the inventions disclosed therein, are commonly assigned to the assignee of the present invention, share common inventorship, and are incorporated herein by reference for all purposes as if fully set forth herein.

According to certain of the inventions introduced and taught in the above-incorporated patent documents, presbyopia, and certain other eye disorders (e.g., hyperopia, primary open angle glaucoma, ocular hypertension, etc.), may suitably be treated by increasing the effective working distance of the ciliary muscle. This may be accomplished by increasing the distance between the ciliary muscle and the lens equator, preferably by

-10-

increasing the diameter of the sclera (i.e., scleral expansion) in the region of the ciliary body.

According to an advantageous embodiment, the effective working distance of the ciliary muscle may suitably be increased by implanting, within pockets surgically formed in the sclera of the eye, a plurality of prostheses designed to place an outward traction on the sclera in the region of the ciliary body. Each prosthesis comprises an elongated base having a first end and a second end and one of a ridge or a crest. The implanted prosthesis applies an outward force on the scleral pocket to elevate the portion of the sclera attached thereto to increase the effective working distance of the ciliary muscle of the eyeball. The plurality of prostheses are therefore designed to apply an outwardly directed force to the sclera cooperatively.

An advantageous embodiment of the prosthesis of the invention disclosed in the above-incorporated patent documents has a substantially circumferential body. The circumferential body has a top surface that is adapted for placement against the outer wall of the pocket surgically formed in the sclera, applying an outward force thereto.

Unfortunately, due to its circumferential body shape, a bottom surface of the prosthesis has limited surface contact with the inner wall of the surgically formed scleral pocket, generally in the area of the first and second ends thereof. Due, at least in part, to the disproportionate surface contact of the top surface relative to the bottom surface of the body of the prosthesis, the prosthesis tends: (i) to slide back and forth within the scleral pocket causing the same to be less effective in treating presbyopia, and (ii) to turn or to

-11-

topple over within the scleral pocket causing the same be substantially ineffective in treating presbyopia.

Turning initially to FIGURE 1, illustrated a top plan view of an advantageous embodiment of an improved scleral prosthesis in accordance with the principles of the present invention. To overcome the above-identified deficiencies of the circumferential body prosthesis, the improved prosthesis of the present invention comprises a body (generally designated 100), having a first end and a second end (generally designated 105a and 105b, respectively), that is adapted to expand a contacted sclera to increase the effective working distance of the ciliary muscle of the eyeball while providing means for stabilizing the prosthesis relative to the contacted sclera. The body 100 includes a top surface 110 that may suitably be adapted to contact ocular tissue within a pocket (or loop) surgically formed within the sclera of the eyeball. Surgical procedures for suitably forming an appropriate scleral pocket are described in the above-incorporated patent documents and further discussion is not necessary for the purposes of this patent document. Exemplary top surface 110 is illustratively shown having a convex planform.

Top surface 100 includes a perimeter 115 that, according to the illustrated embodiment, has a convex, sloped, or otherwise non-sharp edge to avoid cutting, tearing or otherwise damaging the sclera, particularly the surgically formed scleral pocket. It should be noted that the first and second ends 105a,b of body 100 illustratively include a more pronounced slope relative to the remainder of top surface 110 (described in greater detail below).

FIGURE 2 illustrates a side elevational view of the embodiment of the scleral prosthesis of FIGURE 1. The

-12-

prosthesis body 100 again has first and second ends 105a,b, top surface 110, non-sharp edges 115 and a bottom surface 120. Exemplary bottom surface 120 is illustratively shown having a substantially straight planform relative to top surface 110. Preferably, bottom surface 120 is wider than the maximum height of prosthesis body 100.

It should be noted that the exemplary shapes of top surface 110 and bottom surface 120 are provided for illustrative purposes only. Those of skill in the art will understand that body 100 may have any shape suitably adapted, via a cooperation among the shapes of the surfaces of the body, to exert an outward force on the scleral pocket to elevate the portion of the sclera attached thereto to increase the effective working distance of the ciliary muscle of the eyeball, whether such surface is convex, concave, circumferential or otherwise.

It should be further noted that advantageous and exemplary dimensions of body 100 are provided, again for illustrative purposes. Any suitable body planform of dimensions appropriate and in accordance with the principles of the present invention may be used. To that end, exemplary first and second ends 105a,b, in cooperation with top and bottom surfaces 110, 120, provide a means for stabilizing the prosthesis within a surgically formed pocket within the sclera of the eyeball, enabling prosthesis body 100 to substantially permanently exert an outward force on the scleral pocket to elevate the portion of the sclera attached thereto to increase the effective working distance of the ciliary muscle.

To that end, exemplary bottom surface 120 is adapted for increased surface contact with the ocular tissue within the surgically formed pocket relative to the prior

-13-

embodiments of the prosthesis of the above-incorporated patent documents. This increased ocular surface tissue contact at least substantially eliminates turning over, toppling over or otherwise rotating of the prosthesis body within the scleral pocket thereby ensuring effective treatment of presbyopia.

Bottom surface 120 surface may suitably be adapted to contact an amount of ocular tissue that is at least substantially equal to an amount of ocular tissue contacted by top surface 100 within the surgically formed scleral pocket. In alternate embodiments, this relationship may be altered based upon the planform of body 100. For instance, the area of bottom surface 120 may suitably be greater than the area of top surface 110.

Turning to first and second ends 105a,b, each exemplary end is adapted to fix body 100 within a surgically formed pocket through a physical combination/cooperation of (i) a sloping minor portion 125 of top surface 110 relative to a major portion 130 of top surface 110, and (ii) a groove 135. This exemplary physical combination/cooperation at least substantially fixes body 100 within a surgically formed pocket within the scleral pocket thereby ensuring effective treatment of presbyopia.

It should be noted that although first and second ends 105a,b have a partially concave portion 125 of top surface 110 and grooves 135a,b provide a partially concave bottom surface 120, alternate embodiments may include at least one end 105 that has a partially convex top surface, or bottom surface 120 that may suitably include at least one portion that is at least partially convex.

Regardless, the physical cooperation among the various dimensions and characteristics (e.g., smooth, coarse,

-14-

finished, polished, etc.) of the surfaces and ends of prosthesis body 100, suitable means for stabilizing the same within a surgically formed pocket within the sclera of the eyeball.

5 Thus, the exemplary embodiment of FIGURES 1 and 2 illustrates advantageous features wherein top surface 110 starts with a concave surface 125 at first end 105a for approximately 750 microns and then moves smoothly to a smooth convex-like curve for four millimeters, and then to
10 another concave surface 125 at second end 105b for approximately another 750 microns - for a total top surface 110 length of 5.5 millimeters. The radius of curvature of the major convex surface is approximately 9 millimeters, the interconnecting curve has a radius of approximately 153
15 microns and the concave surface has a radius of approximately 500 microns. The concave surface forms a rounded portion having a radius of curvature of approximately 125 microns that connects to bottom surface 120. Bottom surface 120 has a straight part which extends
20 for approximately 500 microns to a concavity that has a radius of curvature of approximately 500 microns and a height of approximately 150 microns. The concavity forms a groove illustratively extending through the whole bottom surface 120 of body 100. A major portion of bottom surface
25 120 extends approximately 3.5 millimeters between the first groove and a second groove (the second groove being substantially identical to the first groove).

Turning to FIGURE 3, illustrated is an exemplary bottom plan view of the embodiment of the scleral prosthesis of FIGURES 1 and 2. It should again be noted
30 that width, length, or other common dimensions need not be the same, meaning, for instance, that bottom surface 120

may suitably be larger in area than top surface 110. Turning to FIGURE 4, illustrated is a top-side isometric view of the embodiment of the scleral prosthesis of FIGURES 1 to 3. Again, the exemplary non-sharp edges are shown. Turning to FIGURE 5, illustrated is a top plan view of one end of the embodiment of the scleral prosthesis of FIGURES 1 to 4. Finally, turning to FIGURE 6, illustrated is a bottom-side isometric view of the embodiment of the scleral prosthesis of FIGURES 1 to 5.

Other important features of the exemplary stabilizing means 105a,b, and 120 (in cooperation with top surface 110), of the illustrated embodiment, is that the width of body 100 is preferably larger than its maximum height - in previous prosthesis embodiments, width was not larger than the maximum height, and enabled turning over, etc. Further, bottom surface 120 is relatively flat except for groves 135 or any other suitable means for fixing prosthesis body 100 within the scleral pocket (e.g., hooks, fasteners, clips, etc.). Exemplary groves 135 therefore act to prevent prosthesis body 100 from sliding - groves 135 may suitably be positioned in line with the incision to form the scleral pocket causing the incision to "curve up" as a result of the pressure into the grove, thereby preventing the prosthesis from sliding in either direction. Thirdly, first or second end 105a,b include a concavity to facilitate ease of entrance into the scleral pocket.

In short, ends 105a,b cooperate to ease insertion into the scleral pocket and to fix the same once appropriately positioned therein. Alternate means for fixing, or, more globally, stabilizing the prosthesis include positioning a hole in the prosthesis body and suturing the same, gluing

-16-

one or more surfaces of the same to scleral pocket, a plurality of scleral pockets (or loops).

Yet another advantage of having a total body mass or "thickness" is that the present prosthesis provides increased lift relative to prior embodiments disclosed in the above-incorporated patent documents, which is a primary object of the prostheses.

The foregoing prosthesis may be manufactured in accord with the methods set forth in the above-incorporated patent documents or otherwise known, may be from materials set forth in the above-incorporated patent documents or otherwise known, may be surgically implanted as set forth in the above-incorporated patent documents or as otherwise known, such as an injection wherein the prosthesis would be inserted and then possibly filled with fluid, plastic or otherwise (in an embodiment wherein the ends extend beyond the scleral pocket, the body of the prosthesis may be filled the end actually become wider than the incision, precluding movement, including, for instance, new metals.

The present invention has been described in detail. Those skilled in the art will understand that various changes, substitutions and alterations may be made herein without departing from the spirit and scope of the invention in its broadest form.

WHAT IS CLAIMED IS:

1. A prosthesis adapted for contact with the sclera of an eyeball, said prosthesis comprising a body having a first end and a second end, said body having a planform adapted to expand said contacted sclera to increase the effective working distance of the ciliary muscle of the eyeball.

2. The prosthesis set forth in Claim 1 wherein said body further comprises a top surface that is adapted to contact ocular tissue within a pocket surgically formed within the sclera of the eyeball.

3. The prosthesis set forth in Claim 2 wherein said top surface is circumferentially shaped and adapted to exert an outward force on the scleral pocket to elevate the portion of the sclera attached thereto to increase the effective working distance of the ciliary muscle of the eyeball.

4. The prosthesis set forth in Claim 2 wherein said body further comprises a means for stabilizing said prosthesis within said surgically formed pocket within the sclera of the eyeball.

5. The prosthesis set forth in Claim 4 wherein said stabilizing means includes a bottom surface that is adapted to contact ocular tissue within said surgically formed pocket.

6. The prosthesis set forth in Claim 5 wherein said ocular tissue contact of said bottom surface of said body

-18-

is at least substantially equal to said ocular tissue contact of said top surface of said body.

5 7. The prosthesis set forth in Claim 4 wherein said stabilizing means includes at least one of said first end and said second end that is adapted to fix said body within said surgically formed pocket.

10 8. The prosthesis set forth in Claim 7 wherein said at least one of said first end and said second end include has a partially concave top surface.

15 9. The prosthesis set forth in Claim 7 wherein said at least one of said first end and said second end include has a partially convex top surface.

20 10. The prosthesis set forth in Claim 7 wherein said at least one of said first end and said second end include has a partially concave bottom surface.

 11. The prosthesis set forth in Claim 7 wherein said at least one of said first end and said second end include has a partially convex bottom surface.

25 12. A prosthesis adapted for contact with the sclera of an eyeball, said prosthesis comprising a body having a first end and a second end, said body having a planform adapted to expand said contacted sclera to increase the effective working distance of the ciliary muscle of the eyeball and further means for stabilizing said prosthesis
30 within said surgically formed pocket within the sclera of the eyeball.

13. The prosthesis set forth in Claim 12 wherein said body further comprises a top surface that is adapted to contact ocular tissue within a pocket surgically formed within the sclera of the eyeball.

5

14. The prosthesis set forth in Claim 13 wherein said top surface is circumferentially shaped and adapted to exert an outward force on the scleral pocket to elevate the portion of the sclera attached thereto to increase the effective working distance of the ciliary muscle of the eyeball.

10

15. The prosthesis set forth in Claim 12 wherein said stabilizing means includes a bottom surface that is adapted to contact ocular tissue within said surgically formed pocket.

15

16. The prosthesis set forth in Claim 15 wherein said ocular tissue contact of said bottom surface of said body is at least substantially equal to said ocular tissue contact of said top surface of said body.

20

17. The prosthesis set forth in Claim 12 wherein said stabilizing means includes at least one of said first end and said second end that is adapted to fix said body within said surgically formed pocket.

25

18. The prosthesis set forth in Claim 17 wherein said at least one of said first end and said second end include has a partially concave top surface.

30

-20-

19. The prosthesis set forth in Claim 17 wherein said at least one of said first end and said second end include has a partially convex top surface.

5 20. The prosthesis set forth in Claim 17 wherein said at least one of said first end and said second end has a partially concave bottom surface.

10 21. The prosthesis set forth in Claim 17 wherein said at least one of said first end and said second end has a partially convex bottom surface.

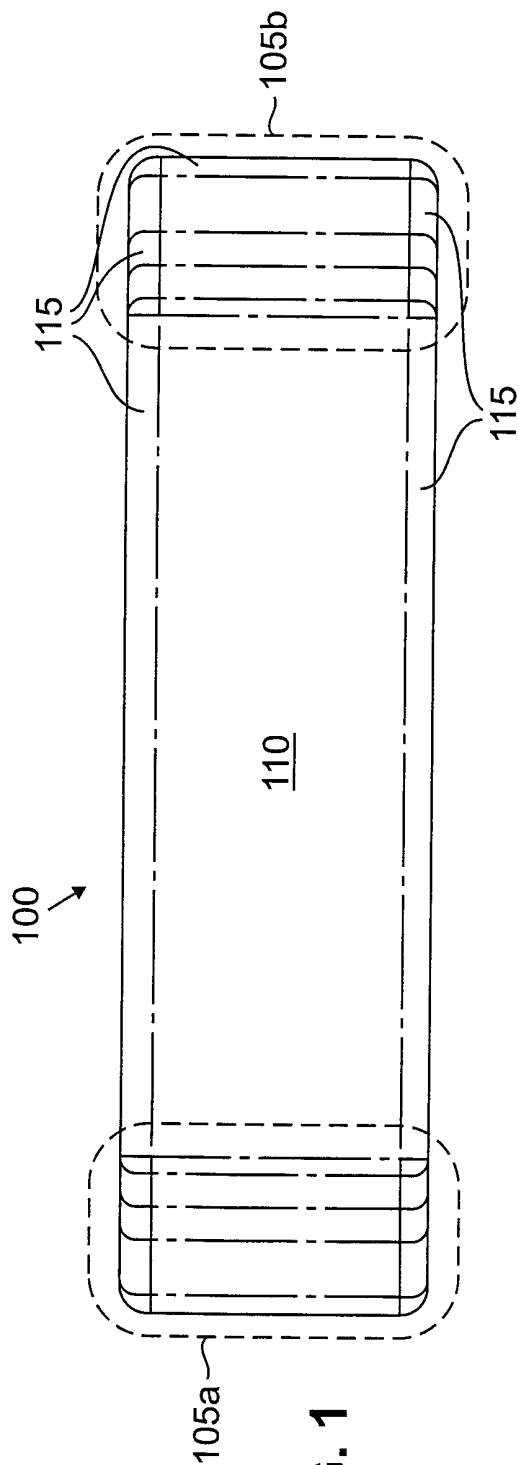

FIG. 1

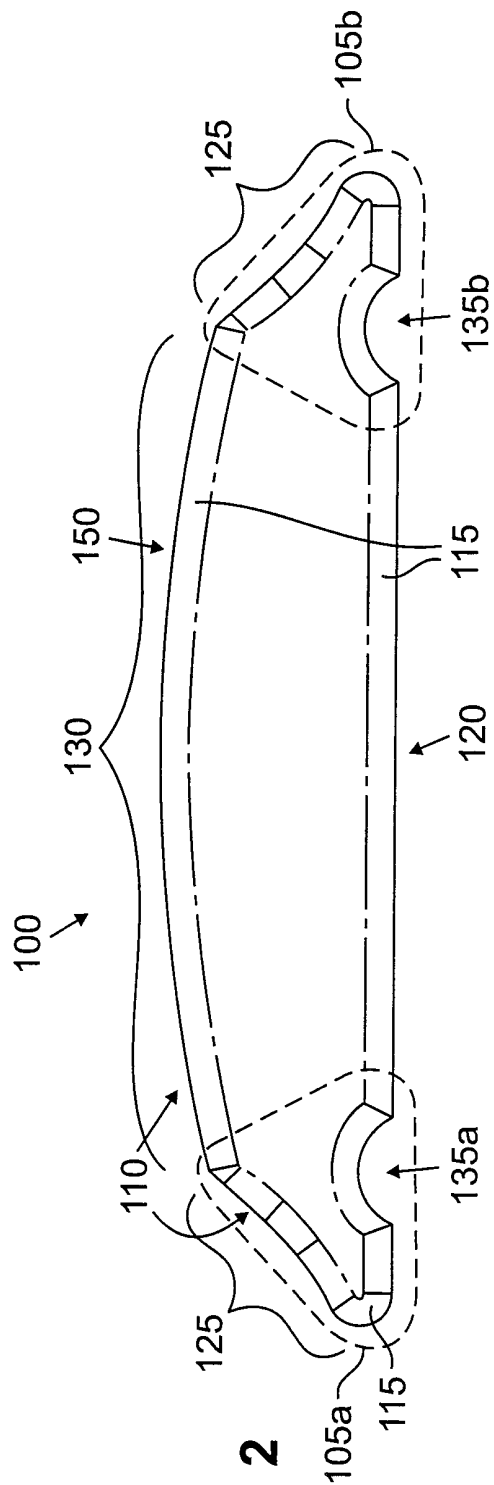

FIG. 2

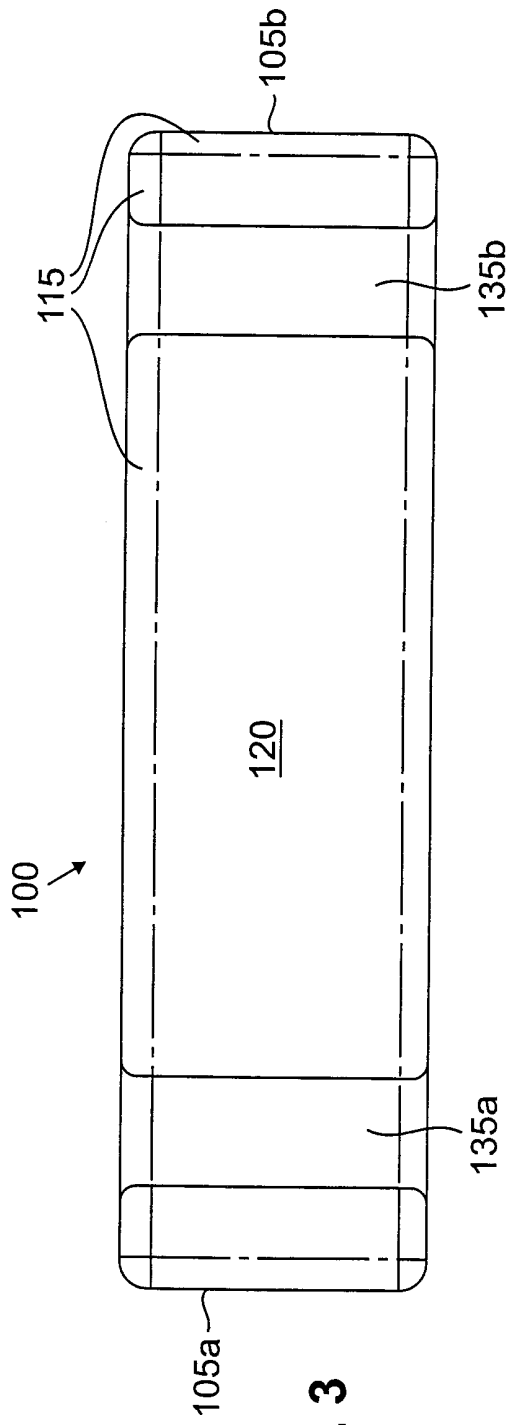

FIG. 3

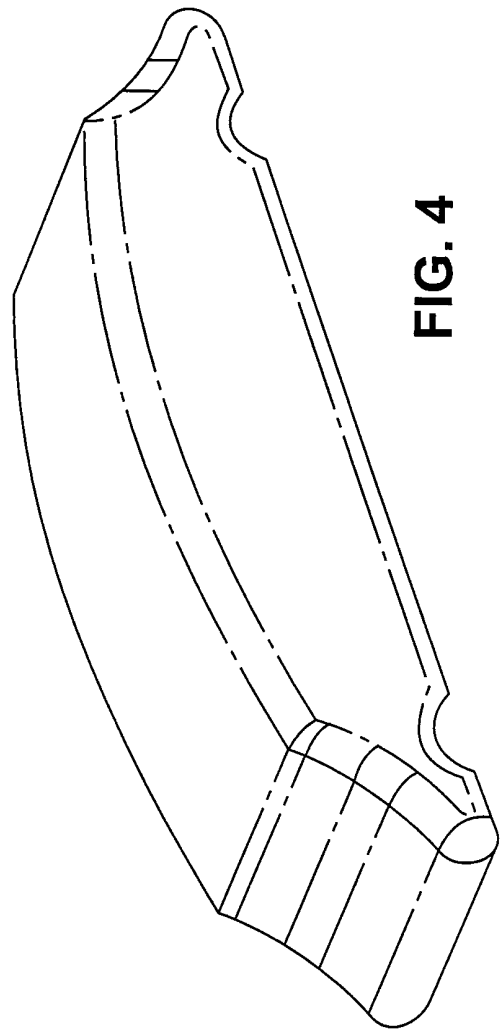

FIG. 4

3/3

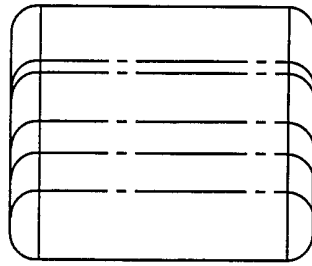

FIG. 5

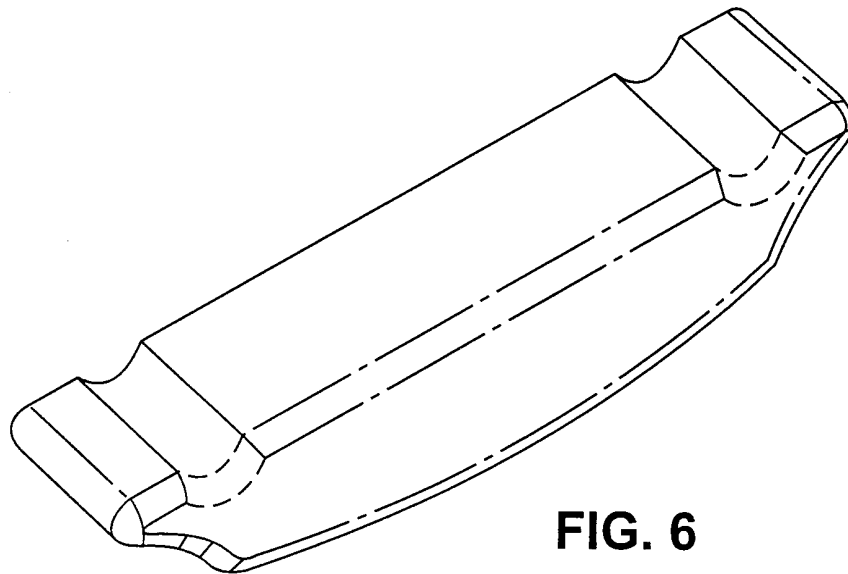

FIG. 6

INTERNATIONAL SEARCH REPORT

International Application No

PCT/US 00/15691

A. CLASSIFICATION OF SUBJECT MATTER
IPC 7 A61F2/14

According to International Patent Classification (IPC) or to both national classification and IPC

B. FIELDS SEARCHED

Minimum documentation searched (classification system followed by classification symbols)
IPC 7 A61F

Documentation searched other than minimum documentation to the extent that such documents are included in the fields searched

Electronic data base consulted during the international search (name of data base and, where practical, search terms used)

EPO-Internal

C. DOCUMENTS CONSIDERED TO BE RELEVANT

| Category | Citation of document, with indication, where appropriate, of the relevant passages | Relevant to claim No. |
|----------|---|---------------------------|
| P, X | FR 2 784 287 A (BAIKOFF GEORGES) 14 April 2000 (2000-04-14) page 1, line 17 - line 24; claims; figures page 4, line 15 - line 29 | 1, 2, 4, 7, 12, 13, 17 |
| A | --- | 3 |
| A | WO 96 40005 A (KERAVISION INC ;SCHANZLIN DAVID J (US); VERITY STEVEN M (US); SILV) 19 December 1996 (1996-12-19) abstract; figures | 1, 12 |
| A | WO 98 42409 A (SAWUSCH MARK R) 1 October 1998 (1998-10-01) page 6, paragraph 1; figures 1-3 | 1, 12 |

Further documents are listed in the continuation of box C.

Patent family members are listed in annex.

Special categories of cited documents :

"A" document defining the general state of the art which is not considered to be of particular relevance

"E" earlier document but published on or after the international filing date

"L" document which may throw doubts on priority claim(s) or which is cited to establish the publication date of another citation or other special reason (as specified)

"O" document referring to an oral disclosure, use, exhibition or other means

"P" document published prior to the international filing date but later than the priority date claimed

"T" later document published after the international filing date or priority date and not in conflict with the application but cited to understand the principle or theory underlying the invention

"X" document of particular relevance; the claimed invention cannot be considered novel or cannot be considered to involve an inventive step when the document is taken alone

"Y" document of particular relevance; the claimed invention cannot be considered to involve an inventive step when the document is combined with one or more other such documents, such combination being obvious to a person skilled in the art.

"&" document member of the same patent family

Date of the actual completion of the international search

29 September 2000

Date of mailing of the international search report

06/10/2000

Name and mailing address of the ISA

European Patent Office, P.B. 5818 Patentlaan 2
NL - 2280 HV Rijswijk
Tel. (+31-70) 340-2040, Tx. 31 651 epo nl,
Fax: (+31-70) 340-3016

Authorized officer

Neumann, E

INTERNATIONAL SEARCH REPORT

Information on patent family members

International Application No

PCT/US 00/15691

| Patent document cited in search report | Publication date | Patent family member(s) | Publication date |
|--|------------------|---|--|
| FR 2784287 A | 14-04-2000 | AU 6096999 A WO 0021466 A | 01-05-2000 20-04-2000 |
| WO 9640005 A | 19-12-1996 | AU 6107696 A CA 2222130 A EP 0830111 A JP 11507269 T | 30-12-1996 19-12-1996 25-03-1998 29-06-1999 |
| WO 9842409 A | 01-10-1998 | AU 6868498 A | 20-10-1998 |