



INTERNATIONAL APPLICATION PUBLISHED UNDER THE PATENT COOPERATION TREATY (PCT)

<p>(51) International Patent Classification ⁶ : G02B 6/44, E21B 7/18, 7/28, H02G 1/06</p>	<p>A1</p>	<p>(11) International Publication Number: WO 96/02012 (43) International Publication Date: 25 January 1996 (25.01.96)</p>
<p>(21) International Application Number: PCT/GB95/01579 (22) International Filing Date: 5 July 1995 (05.07.95) (30) Priority Data: 94305033.6 8 July 1994 (08.07.94) EP (34) Countries for which the regional or international application was filed: AT et al. (71) Applicant (for all designated States except US): BRITISH TELECOMMUNICATIONS PUBLIC LIMITED COMPANY [GB/GB]; 81 Newgate Street, London EC1A 7AJ (GB). (72) Inventors; and (75) Inventors/Applicants (for US only): MARSDEN, Stephen, Andrew [GB/GB]; 9 Gardeners Walk, Elmswell, Bury St Edmunds, Suffolk IP30 9ET (GB). WETTENGEL, Paul, Frederick [GB/GB]; 3 Peel Yard, Martlesham Heath, Ipswich, Suffolk IP5 7UL (GB). GUMBS, Austin, Bernard [GB/GB]; 36 Epsom Drive, Ipswich, Suffolk IP1 6RU (GB). (74) Agent: PRATT, David, Martin; BT Group Legal Services, Intellectual Property Dept., 13th floor, 151 Gower Street, London WC1E 6BA (GB).</p>		<p>(81) Designated States: AM, AU, BB, BG, BR, BY, CA, CN, CZ, EE, FI, GB, GE, HU, IS, JP, KE, KG, KP, KR, KZ, LK, LR, LT, LV, MD, MG, MN, MW, MX, NO, NZ, PL, RO, RU, SD, SG, SI, SK, TJ, TM, TT, UA, UG, US, UZ, VN, European patent (AT, BE, CH, DE, DK, ES, FR, GB, GR, IE, IT, LU, MC, NL, PT, SE). Published With international search report.</p>
<p>(54) Title: TRANSMISSION LINE INSTALLATION</p>		
<p>(57) Abstract</p> <p>A method of installing a transmission line (such as an optical fibre telecommunications line) in the ground comprises the steps of forming a tunnel in the ground using a mole constituted by a water-jetting head (H) and piping (8) for supplying pressurised water to the head, and positioning the transmission line in the tunnel. The head (H) is guided along a pre-installed buried elongate member such as a twisted copper pair telecommunications line.</p>		

FOR THE PURPOSES OF INFORMATION ONLY

Codes used to identify States party to the PCT on the front pages of pamphlets publishing international applications under the PCT.

AT	Austria	GB	United Kingdom	MR	Mauritania
AU	Australia	GE	Georgia	MW	Malawi
BB	Barbados	GN	Guinea	NE	Niger
BE	Belgium	GR	Greece	NL	Netherlands
BF	Burkina Faso	HU	Hungary	NO	Norway
BG	Bulgaria	IE	Ireland	NZ	New Zealand
BJ	Benin	IT	Italy	PL	Poland
BR	Brazil	JP	Japan	PT	Portugal
BY	Belarus	KE	Kenya	RO	Romania
CA	Canada	KG	Kyrgystan	RU	Russian Federation
CF	Central African Republic	KP	Democratic People's Republic of Korea	SD	Sudan
CG	Congo	KR	Republic of Korea	SE	Sweden
CH	Switzerland	KZ	Kazakhstan	SI	Slovenia
CI	Côte d'Ivoire	LI	Liechtenstein	SK	Slovakia
CM	Cameroon	LK	Sri Lanka	SN	Senegal
CN	China	LU	Luxembourg	TD	Chad
CS	Czechoslovakia	LV	Latvia	TG	Togo
CZ	Czech Republic	MC	Monaco	TJ	Tajikistan
DE	Germany	MD	Republic of Moldova	TT	Trinidad and Tobago
DK	Denmark	MG	Madagascar	UA	Ukraine
ES	Spain	ML	Mali	US	United States of America
FI	Finland	MN	Mongolia	UZ	Uzbekistan
FR	France			VN	Viet Nam
GA	Gabon				

TRANSMISSION LINE INSTALLATION

This invention relates to apparatus for, and a method of, installing a transmission line such as an optical fibre telecommunications line.

5 In the United Kingdom, the telecommunications network includes a trunk network which is substantially completely constituted by optical fibre, and a local access network which is substantially completely constituted by copper pairs. Flexibility in the copper access network is provided at two points en route to the customer; firstly, at street-side cabinets serving up to 600 lines; and secondly, at
10 distribution points serving around 10-15 lines. Eventually, it is expected that the entire network, including the access network, will be constituted by fibre.

The ultimate goal is a fixed, resilient, transparent telecommunications infrastructure for the optical access network, with capacity for all foreseeable service requirements. One way of achieving this would be to create a fully-
15 managed fibre network in the form of a thin, widespread overlay for the whole access topography as this would exploit the existing valuable access network infrastructure. Such a network could be equipped as needs arise, and thereby could result in capital expenditure savings, since the major part of the investment will be the provision of terminal equipment on a 'just in time' basis. It should also
20 enable the rapid provision of extra lines to new or existing customers, and flexible provision or reconfiguration of telephony services.

In order to be completely future proof, the network should be single mode optical fibre, with no bandwidth limiting active electronics within the infrastructure. Consequently, only passive optical networks (PONs) which can
25 offer this total transparency and complete freedom for upgrade, should be considered.

The most common passive optical network is the simplex single star, with point-to-point fibre for each transmit and receive path, from the exchange head end (HE) to the customer network terminating equipment (NTE). This network
30 design has been used throughout the world and meets all the access criteria. It involves high fibre count cables, and unique electro-optic provision at HE and NTE for each customer. The resulting inherent cost can only be justified for large

business users, who generally also require the security of diverse routing, which increases the cost still further.

The advent of optical splitters and wavelength-flattened devices has enabled the concept of the PON to be taken one step further. These passive
5 components allow the power transmitted from a single transmitter to be distributed amongst several customers, thereby reducing and sharing the capital investment.

The use of splitter based PON architecture thus reduces the cost of fibre deployment in the access network. When compared with point-to-point fibre, savings will result from:

- 10 (i) reducing the number of fibres at the exchange and in the network;
- (ii) reducing the amount of terminal equipment at the exchange;
- (iii) sharing the cost of equipment amongst a number of customers;
- (iv) providing a thin, widespread, low cost, fibre infrastructure; and
- (v) providing a high degree of flexibility, and allowing 'just in-time' equipment
15 and service provision.

Additionally, PON architecture can be tailored to suit the existing infrastructure resources (duct and other civil works).

It will be apparent that upgrading the entire UK access network from copper to fibre will involve a major capital investment program. It is important,
20 therefore, to minimise costs wherever possible. The specifications of our International patent applications WO95/07475, WO95/07476, WO95/07477, WO95/07478 & WO95/07486 describe a fibre management system which aims to reduce the cost of providing fibre from local exchanges to the network nodes (equivalent to the distribution points of the copper access network) nearest the
25 customers. The specifications of our International patent applications GB95/00449 and GB95/00450 describe a way of minimising the cost of getting fibre into a customer's premises via a customer lead in (CLI) provided in an external wall of the premises. The present invention is concerned with minimising the cost of getting fibre from just outside a customer's premises to the nearest
30 network node.

The present invention provides a method of installing a transmission line in the ground, the method comprising the steps of forming a tunnel in the ground using a mole constituted by a water-jetting head and piping for supplying

pressurised water to the head, and positioning the transmission line in the tunnel, wherein the head is guided along a pre-installed buried elongate member by manually pushing the piping thereby forming the tunnel adjacent to the elongate member.

5 The pre-installed buried elongate member may be an underground service pipe (water or gas) or cable. Preferably, this member is a telecommunications line such as a twisted copper pair. The method of the invention thus permits the installation of a new telecommunications line using an old telecommunications as a guide, thereby providing a cost-effective way of installing the new
10 telecommunications line from the curtilage to the CLI.

Advantageously, the transmission line is a ruggedised optical fibre which is rodded into the tunnel after the mole has been withdrawn.

Alternatively, the transmission line is an optical fibre transmission line which is propelled along the tunnel by fluid drag of gaseous medium passed
15 through the tunnel, the optical fibre transmission line being installed in the tunnel after the mole has been withdrawn. In this case, a tubular pathway may be positioned within the tunnel prior to the propelling of the optical fibre transmission line, the optical fibre transmission line being propelled along the tubular pathway by fluid drag of said gaseous medium.

20 The tubular pathway may be constituted by tubing which is connected to the mole at the head end thereof, the tubing being positioned in the tunnel by subsequently withdrawing the mole from the tunnel.

Preferably, the method further comprises the step of removing the head from the piping of the mole, connecting a second water-jetting head to the piping,
25 attaching the tubing to the second head, and removing the mole from the tunnel.

The invention also provides a cutting head for a water-jetted mole, the cutting head comprising an elongate main body portion formed with a longitudinally-extending bore for supplying pressurised water to a deflection face formed within the main body portion, a guide member fixed to the main body
30 portion in the region of the deflection face, the guide member being sized and shaped for engagement with a buried elongate guide, an axially-extended slot formed in the main body portion on the other side of the deflection face to the bore, the slot being aligned with the bore and extending to the free end of the main

body portion thereby defining a passage for producing a first, axially-directed water jet which, in use, cuts a tunnel along the side of the guide, and the deflection face being such as to deflect some of the water supplied along the bore so as to define a second, transversely-directed water jet which, in use, washes over the guide
5 member.

Conveniently, deflection face is defined by a radial blind bore formed in the main body portion, the radial blind bore intersecting said first-mentioned bore.

Advantageously, the main body portion is provided with an externally-threaded extension portion at that end thereof remote from the axial slot.

10 Preferably, the guide member is constituted by a guide ring, and one end of the guide ring is fixed to the main body portion, and the other end of the ring is detachably fixed to the main body portion. This facilitates positioning of the guide ring over the buried elongate guide.

The invention will now be described in greater detail, by way of example,
15 with reference to the accompanying drawings, in which:-

Figure 1 is a perspective view of the cutting head of a guided water-jetted mole constructed in accordance with the invention;

Figure 2 is an axial cross-section taken through the front portion of the cutting head of Figure 1;

20 Figure 3 is a plan view of the cutting head front portion;

Figure 4 is a front elevation of the cutting head of Figure 1; and

Figure 5 is an axial cross-section taken through the front portion of a modified form of cutting head.

Referring to the drawings, Figure 1 shows a cutting head H made of
25 stainless steel. The cutting head H has a main body portion 1 and a screw-threaded shank 2. The front end of the main body portion 1 (that is to say that end remote from the shank 2) is shaped to define a tapered nose portion 1a. The main body portion 1 is formed with an axial bore 3 (see Figure 2) which is contiguous with a bore (not shown) in the shank 2. The bore 3 terminates at a
30 deflection face 4 formed in the main body portion 1 by a cylindrical, radial blind bore 5. An axial slot 6 extends forwardly of the bore 5, terminating at the free end of the tapered nose portion 1a. The main body portion 1 is provided with a flexible guide ring 7 made from a multi-stranded, high tensile steel wire which is

surrounded by short tube sections which act as rollers. One end of the guide ring 7 is permanently fixed to the main body portion 1, the other end being detachably fixed to the main body portion by means of a grub screw (not shown). The guide ring 7 is positioned just behind the deflection face 4.

5 The cutting head H is used with a plurality of stainless steel tubes 8 (one of which is shown in Figure 1), each of which has an internally-threaded portion at one end and an externally-threaded portion at the other end. The tubes 8 each have a length of 2m, an external diameter of 10mm and an internal diameter of 6mm. A first of the tubes 8 can be fixed to the screw-threaded shank 2 of the
10 cutting head H by means of its internally-threaded end portion. Subsequently, further tubes 8 can be added (in a manner described below) by interengagement of adjacent internally-threaded and externally-threaded end portions.

The mole described above can be used to tunnel through the earth to provide a route for the subsequent installation of a telecommunications line such
15 an optical fibre line. In particular, the mole can be used to tunnel from the curtilage of a customer's premises to the customer lead in point provided in the wall of those premises.

In order to guide the mole from the curtilage to the CLI, use is made of any service cable or pipe already buried in the ground. Preferably, where there is an
20 existing telecommunications line (i.e. a copper pair) already buried in the ground, this is used to guide the mole. In this case, the first step of the tunnelling process is to dig a small pit at the curtilage so as to expose the buried telecommunications line (drop cable). The guide ring 7 of the cutting head H is then positioned over the cable by releasing the grub screw, positioning the ring over the cable, and then
25 re-applying the grub screw. A first stainless steel tube 8 is then threaded onto the shank 2 of the cutting head. The free end of the rod 8 is then connected to a Gerni 600p water lance (not shown) which is supplied with water at a pressure of 2350psi at a rate of between 17 and 18 litres per minute.

Pressurised water is then supplied to the cutting head H by pressing the
30 trigger of the water lance. Pressurised water is then forced along the bore 3 and against the deflection face 4, resulting in the formation of two separate water jets J1 and J2 (see Figure 2). The water jet J1 is directed generally along the axial slot 6 towards the tapered nose portion 1a of the cutting head H. This jet J1 is

effective to cut a tunnel in the earth in the region of the guiding cable. The other jet J2 is directed upwardly towards the cable and the guide ring 7. This jet J2 forces pressurised water around the cable and the guide ring 7 to prevent earth and stones jamming between the guide ring and the cable, and so preventing the forward movement of the cutting head H. Once the water has been turned on, the operator pushes the tube 8 into the ground. As this occurs, the water jet J1 tunnels into the earth thereby forming a bore adjacent to the guide cable. When the tube 8 has been advanced until the water lance is about to enter the pit, the water is turned off, the lance is unscrewed from the free end of tube 8, and a further tube 8 is threaded onto the first tube 8. The lance is then screwed onto the free end of this second tube 8, the water is turned on again, and the cutting head H is rodded further into the ground by the operator. The procedure is repeated until the cutting head is beneath the customer lead-in point in the wall of the customer's premises. A small pit is then dug at this point to reveal the cutting head H. The cutting head H is then removed from the first tube 8, the tubes 8 are withdrawn from the pit at the curtilage, and a ruggedised optical fibre cable is rodded into the tunnel from either end.

Alternatively, a modified form of cutting head H' (see Figure 5) is fixed to the internally-threaded portion of the first tube 8 by means of an externally threaded shank 12 formed at one end of a main body portion 11. The main body portion 11 and the shank 12 are formed with a central blind bore (not shown) for feeding water to a number of water jets 13 (only one of which can be seen) formed in the main body portion. An extension 14 is formed on that side of the main body portion 11 remote from the shank 12, the extension being provided with an internally-threaded shank portion 15. In use, a tube clamp (not shown) formed with an externally threaded shank is screwed into the internally-threaded shank portion 15, and a blown fibre tube is fixed in the clamp. This tube is typically made of a polymer such as a high density polythene, and has an outer diameter of 8mm and an inner diameter of 3.5mm. The tube is preferably supplied from a coil. Pressurised water is then supplied to the cutting head H' by pressing the trigger of the water lance, and the line of tubes 8 and the cutting head H' are withdrawn from the tunnel by pulling from the pit at the curtilage. As the cutting head H' travels along the tunnel water escaping from the jets 13 is effective to

remove any earth or stone which might otherwise impede its passage. When the cutting head H' reaches the pit at the curtilage, the blown fibre tube is removed from its clamp, after which an optical fibre cable can be blown through the tube in the known manner.

5 In some cases, it may be possible to replace the cutting head H' by a simple threaded member for fixing to the first tube 8 and for threading in a tube clamp.

 It will be apparent that the method and apparatus described above could be modified. For example, in order to reduce the amount of effort needed to install
10 the tubes 8, a wetting agent could be added to the water supplied to the lance. A suitable wetting agent, which should be bio-degradable in soil, is a Sub-soil Boring Fluid supplied by Enviro Chem.

 It would also be possible to install ducting for housing a new transmission line at the same time as the mole cuts the tunnel. For example, lengths of plastics
15 tubing could be pushed over the tubes 8 as the mole is rodded in, the lengths of tubing being glued together, as they are added, using plastics collars.

 The method of the invention results in a time-saving of approximately 70% (when compared with standard open trench and back fill methods or those utilising pneumatic moles) in the upgrade of direct buried telecommunications line customer
20 feeds. This assumes a mixture of grass, flower beds and paving that would be considered a typical front garden. The method requires the digging of only two small pits, one at either end of the feed, and this minimises re-instatement costs. At the same time, there is minimised disruption to areas that have public access and to the customer's property. Moreover, the method of the invention involves a
25 single man, low skill operation, and so is cheap to carry out.

 Although the method of the invention is intended primarily for the replacement of direct, in ground, customer drop cables, scaled versions of the technique could be used to replace any of the other utility lead-ins, for example gas pipes, water pipes, electric cables etc. In addition to the customer premises to
30 curtilage location, scaled versions of the technique could be used for replacement of directly buried cables, ducts and pipes throughout the network infrastructure of all the utilities. In particular, for telecommunications applications, in addition to the customer drop provision, the method of the invention could be used for the

replacement and upgrading of distribution cables in frontage "T" topologies, in the replacement of damaged directly buried cable throughout the network, and in the replacement of blocked lead-in ducts.

CLAIMS

1. A method of installing a transmission line in the ground, the method comprising the steps of forming a tunnel in the ground using a mole constituted by
5 a water-jetting head and piping for supplying pressurised water to the head, and positioning the transmission line in the tunnel, wherein the head is guided along a pre-installed buried elongate member by manually pushing the piping thereby forming the tunnel adjacent to the elongate member.
- 10 2. A method as claimed in claim 1, wherein the transmission line is a ruggedised optical fibre which is rodded into the tunnel after the mole has been withdrawn.
3. A method as claimed in claim 1, wherein the transmission line is an optical
15 fibre transmission line which is propelled along the tunnel by fluid drag of gaseous medium passed through the tunnel, the optical fibre transmission line being installed in the tunnel after the mole has been withdrawn.
4. A method as claimed in claim 3, wherein a tubular pathway is positioned
20 within the tunnel prior to the propelling of the optical fibre transmission line, the optical fibre transmission line being propelled along the tubular pathway by fluid drag of said gaseous medium.
5. A method as claimed in claim 4, wherein the tubular pathway is
25 constituted by tubing which is connected to the mole at the head end thereof, the tubing being positioned in the tunnel by subsequently withdrawing the mole from the tunnel.
6. A method as claimed in claim 5, further comprising the step of removing
30 the head from the piping of the mole, connecting a second water-jetting head to the piping, attaching the tubing to the second head, and removing the mole from the tunnel.

7. A cutting head for a water-jetted mole, the cutting head comprising an elongate main body portion formed with a longitudinally-extending bore for supplying pressurised water to a deflection face formed within the main body portion, a guide member fixed to the main body portion in the region of the
5 deflection face, the guide member being sized and shaped for engagement with a buried elongate guide, an axially-extended slot formed in the main body portion on the other side of the deflection face to the bore, the slot being aligned with the bore and extending to the free end of the main body portion thereby defining a
10 passage for producing a first, axially-directed water jet which, in use, cuts a tunnel along the side of the guide, and the deflection face being such as to deflect some of the water supplied along the bore so as to define a second, transversely-directed water jet which, in use, washes over the guide member.

8. A cutting head as claimed in claim 7, wherein the deflection face is
15 defined by a radial blind bore formed in the main body portion, the radial blind bore intersecting said first-mentioned bore.

9. A cutting head as claimed in claim 7 or claim 8, wherein said free end of the main body portion is tapered.
20

10. A cutting head as claimed in any one of claims 7 to 9, wherein the main body portion is provided with an externally-threaded extension portion at that end thereof remote from the axial slot.

25 11. A cutting head as claimed in any one of claims 7 to 10, wherein the guide member is constituted by a guide ring.

12. A cutting head as claimed in claim 11, wherein one end of the guide ring is fixed to the main body portion, and the other end of the ring is detachably fixed to
30 the main body portion.

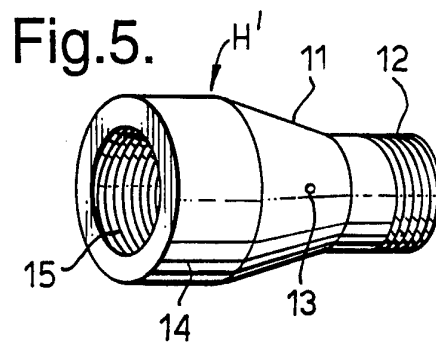
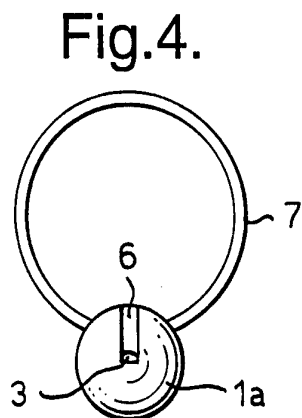
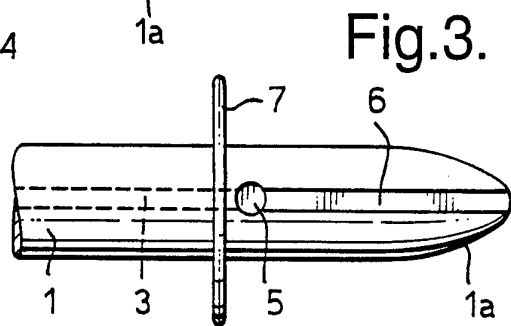
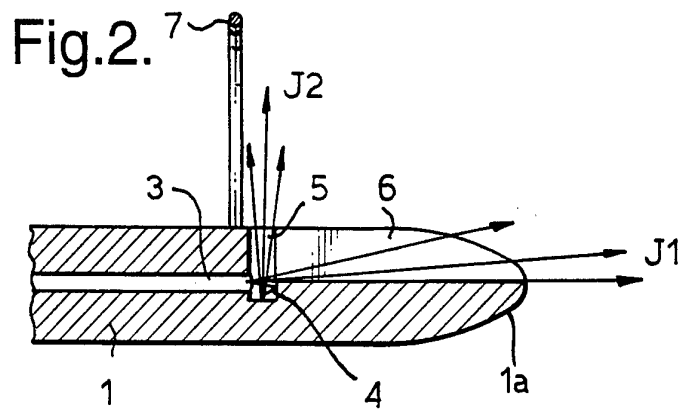
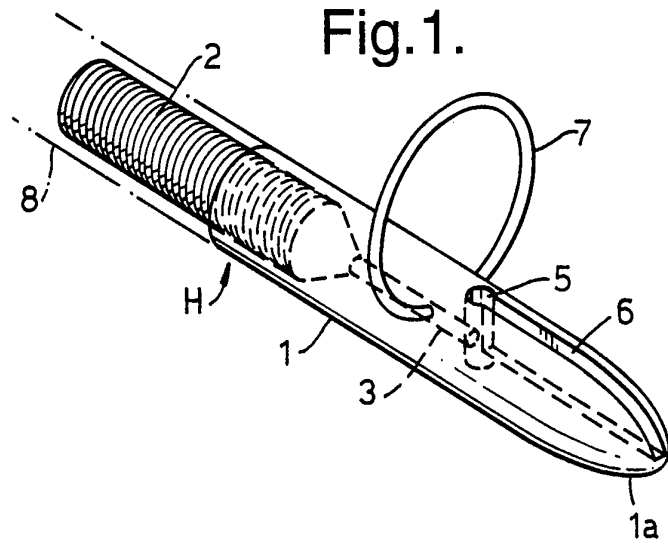

INTERNATIONAL SEARCH REPORT

Inter. nal Application No
PCT/GB 95/01579

A. CLASSIFICATION OF SUBJECT MATTER
IPC 6 G02B6/44 E21B7/18 E21B7/28 H02G1/06

According to International Patent Classification (IPC) or to both national classification and IPC

B. FIELDS SEARCHED

Minimum documentation searched (classification system followed by classification symbols)
IPC 6 G02B E21B H02G

Documentation searched other than minimum documentation to the extent that such documents are included in the fields searched

Electronic data base consulted during the international search (name of data base and, where practical, search terms used)

C. DOCUMENTS CONSIDERED TO BE RELEVANT

Category *	Citation of document, with indication, where appropriate, of the relevant passages	Relevant to claim No.
X	DE,C,33 31 291 (ELECTRIC POWER RESEARCH INST.) 24 April 1986	1,7
A	---	2,8,9,11
X	GB,A,2 103 888 (E.P.R.I.) 23 February 1983 see claims; figures	1
X	GB,A,2 085 670 (E.P.R.I.) 28 April 1982 see claims; figures	1
A	GB,A,2 129 627 (WATER RESEARCH CENTER) 16 May 1984 see claims; figures	1,2
A	DE,C,38 26 513 (P.SCHMIDT) 16 August 1990 see claims; figures	1
	--- -/--	

Further documents are listed in the continuation of box C.

Patent family members are listed in annex.

* Special categories of cited documents :

- "A" document defining the general state of the art which is not considered to be of particular relevance
- "E" earlier document but published on or after the international filing date
- "L" document which may throw doubts on priority claim(s) or which is cited to establish the publication date of another citation or other special reason (as specified)
- "O" document referring to an oral disclosure, use, exhibition or other means
- "P" document published prior to the international filing date but later than the priority date claimed

- "T" later document published after the international filing date or priority date and not in conflict with the application but cited to understand the principle or theory underlying the invention
- "X" document of particular relevance; the claimed invention cannot be considered novel or cannot be considered to involve an inventive step when the document is taken alone
- "Y" document of particular relevance; the claimed invention cannot be considered to involve an inventive step when the document is combined with one or more other such documents, such combination being obvious to a person skilled in the art.
- "&" document member of the same patent family

Date of the actual completion of the international search

22 September 1995

Date of mailing of the international search report

20. 10. 95

Name and mailing address of the ISA

European Patent Office, P.B. 5818 Patentlaan 2
NL - 2280 HV Rijswijk
Tel. (+ 31-70) 340-2040, Tx. 31 651 epo nl,
Fax: (+ 31-70) 340-3016

Authorized officer

Pfhler, R

INTERNATIONAL SEARCH REPORT

Inter. nal Application No

PCT/GB 95/01579

C.(Continuation) DOCUMENTS CONSIDERED TO BE RELEVANT

Category *	Citation of document, with indication, where appropriate, of the relevant passages	Relevant to claim No.
X,P	EP,A,0 606 711 (BICC) 20 July 1994 see claims; figures -----	1,3

INTERNATIONAL SEARCH REPORT

information on patent family members

Inter. Application No

PCT/GB 95/01579

Patent document cited in search report	Publication date	Patent family member(s)	Publication date
DE-C-3331291	08-03-84	US-A- 4519462	28-05-85
		AU-B- 557637	24-12-86
		AU-B- 1804783	08-03-84
		CA-A- 1195515	22-10-85
		DE-A- 3331291	08-03-84
		FR-A- 2532670	09-03-84
		GB-A, B 2126436	21-03-84
		JP-B- 1035565	26-07-89
		JP-C- 1551563	23-03-90
		JP-A- 59063910	11-04-84
GB-A-2103888	23-02-83	US-A- 4403667	13-09-83
		AU-B- 547103	03-10-85
		AU-A- 8601382	10-02-83
		CA-A- 1182652	19-02-85
		DE-A- 3228637	17-02-83
		FR-A- 2510635	04-02-83
		JP-C- 1390526	23-07-87
		JP-A- 58045878	17-03-83
		JP-B- 61061945	27-12-86
GB-A-2085670	28-04-82	US-A- 4385667	31-05-83
		AU-B- 552005	22-05-86
		AU-A- 7394181	22-04-82
		CA-A- 1163449	13-03-84
		FR-A, B 2492179	16-04-82
		JP-C- 1323800	27-06-86
		JP-A- 57077785	15-05-82
		JP-B- 60053157	22-11-85
		US-A- 4534425	13-08-85
		US-A- 4493379	15-01-85
GB-A-2129627	16-05-84	AU-B- 1936583	29-03-84
		EP-A- 0109739	30-05-84
		US-A- 4647251	03-03-87
		GB-A, B 2163232	19-02-86
		GB-A, B 2163301	19-02-86
GB-A, B 2163302	19-02-86		
DE-C-3826513	08-02-90	DE-A, C 3826513	08-02-90

INTERNATIONAL SEARCH REPORT

information on patent family members

International Application No

PCT/GB 95/01579

Patent document cited in search report	Publication date	Patent family member(s)	Publication date
DE-C-3826513		EP-A- 0353442	07-02-90
		JP-A- 2070883	09-03-90
		US-A- 5096000	17-03-92

EP-A-0606711	20-07-94	NONE	
