

*D. Matther,*  
*Spark Arrester,*

*No. 1,920,*

*Patented Dec. 31, 1840.*

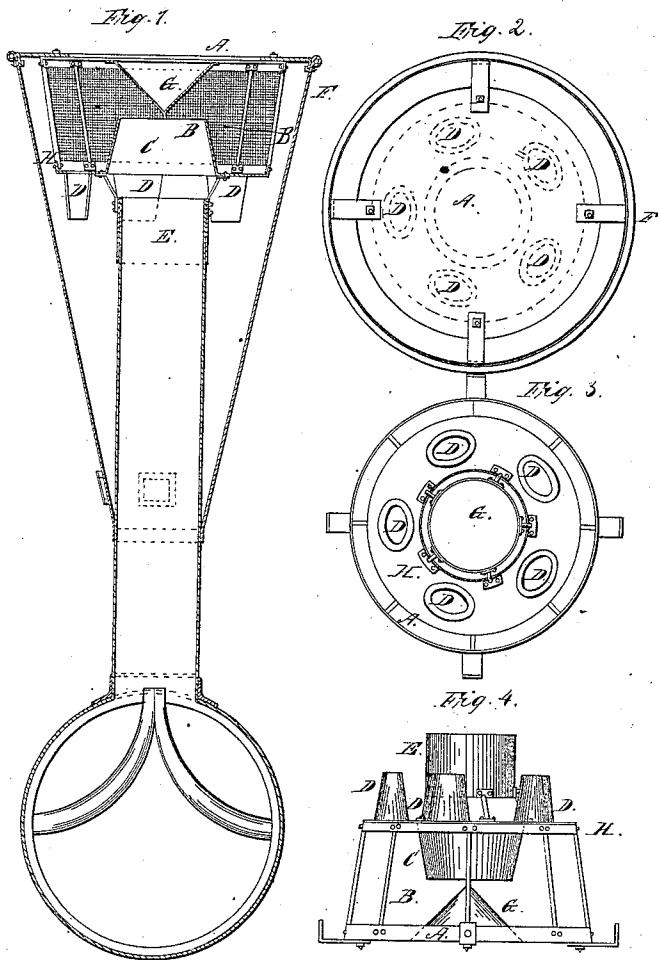

# UNITED STATES PATENT OFFICE.

DAVID MATTHEW, OF SCHENECTADY, NEW YORK.

## SPARK-ARRESTER.

Specification forming part of Letters Patent No. 1,920, dated December 21, 1840; Reissued March 4, 1856, No. 357.

*To all whom it may concern:*

Be it known that I, DAVID MATTHEW, of the city and county of Schenectady and State of New York, have invented a new and useful Machine to be Used upon Smoke-Pipes of Locomotive-Engines to Catch Sparks and Cinders; and I do hereby declare that the following is a full, clear, and exact description of the construction and operation of the same, reference being had to the annexed drawings, making a part of this specification, in which—

Figure 1 is a view of the cross section; Fig. 2 is a top view; Fig. 3, a bottom view and Fig. 4 a side view of the said improvement.

The improvement prevents the escape of sparks and cinders from the smoke pipe of the engine thereby securing great comfort to travelers in railroad cars and security against fire to contiguous erections and combustible materials.

*The top of this spark catcher.*—A, Fig. 2, is a flat plate of iron about 35 inches in diameter and has a cone G, upon the lower or under side (see G, Fig. 1) 16 inches in diameter pointing downward, the point opposite the center of the plate and standing at an angle of 45 degrees from the plate A, to the point; this cone is riveted to the center of plate A. Around the edge of plate A, is a flange 2½ inches wide turned downward at right angles with the plate. Below this and about 14 inches from plate A, is another plate H connected to plate A, by means of eight round iron braces of about ⅜ of an inch diameter with feet riveted to the flange of plate A, and to plate H, five of these braces between plates A, and H are seen in Fig. 1. This bottom plate H is about 31 inches in diameter with a hole in the center 16 inches diameter and a tunnel mouth pipe C, Figs. 1, and 4, nine inches long, 14 inches in diameter at the top coming up about as high as the lowest point of cone G, and is riveted to plate H. There are also five other holes through plate H of an oval shape about 7 inches by 4 into which pass taper pipes about 8 inches long, below and tapering down to about 5 by 3 inches around the outside of chimney E and are riveted to plate H. These pipes are marked in the figures letter D. Around the spark catcher and between the plates A, and H is a wire gauze sewed to the flanges of plates A, and H, in

which are small holes made for the purpose or may be fastened by means of hoops. This gauze is 14½ inches wide and presents a surface of about 1,400 superficial inches through which the smoke, steam and air pass through. On the outside of chimney or smoke pipe E is an outer casing F, of sheet iron rising in the form of a cone reversed about 25 inches above chimney E. The spark catcher is kept firm by 4 braces extending from the top plate A, (see Fig. 3) to the outer casing F, and are bolted to it. Between the top of chimney E and plate H, there is a space of 3 inches. A pipe of proper length to hold steadily is fitted over the top and upon the outside of chimney E like the joint of a stove pipe. The top of this joint of pipe is connected with plate H of the spark catcher by means of five iron braces riveted to the pipe and to plate H. When the engine is at work all the larger sparks and cinders are thrown by the exhaust steam through the chimney into the spark catcher and strike the top plate A, when they fall back upon plate H and pass down through pipes D into the outer casing outside of the chimney E, the smoke and steam passing out through the gauze. If any of the particles are small enough to be carried by force of the current of air, or smoke through the gauze they then strike the outer casing F and drop down outside the chimney. In this improvement there is always a free passage for the smoke and steam by means of the gauze and the space between the spark catcher and the outer casing and also the space between the top of the chimney and the spark catcher which prevents all choking or obstruction in getting up steam or in the operation of it when got up; among the benefits of this improvement is that of a free passage for the smoke, steam and air to pass off without necessarily passing through the spark catcher or gauze thereby avoiding the gumming or clogging up of the gauze to which it is subject particularly in damp weather. This is obtained by leaving the space between the chimney E and the spark catcher or tunnel mouth pipe C equal to the area of the chimney; the smoke, steam and air pass off in a horizontal direction and then rise nearly perpendicular and escape at the top of the casing; as the smoke, steam and air are thus passing off horizontally there being no cur-

rent or force of air between the chimney and casing to force them up the sparks and cinders fall down the tunnel mouth pipe C, which being nearly double the area or size of  
5 the pipe E causes the sparks that pass through the gauze to fall back into the reservoir. The tunnel mouth pipe C being so much larger than pipe E when the engine exhausts the smoke, steam and air  
10 are displaced out of the pipe C with the same velocity that it passes out of pipe, E, and causes a current down the outside of the spark catcher to supply the space, causing a great part of those particles which  
15 pass through the gauze to fall into the reservoir.

The experiments with this improvement

show that in working the engine up to its proper power with pine wood about three bushels of sparks and cinders accumulate 20 per hour.

The undersigned claims as his own invention—

The combination of the plate H, and A, constructed in the manner described above 25 having a wire gauze arranged between them with the casing surrounding the chimney of the locomotive in the form as set forth.

DAVID MATTHEW.

Witnesses:

PLATT POTTER,  
B. F. POTTER.

[FIRST PRINTED 1913.]