

(No Model.)

T. CRANEY.
BAG FILLER.

No. 470,475.

Patented Mar. 8, 1892.

Fig. 1.

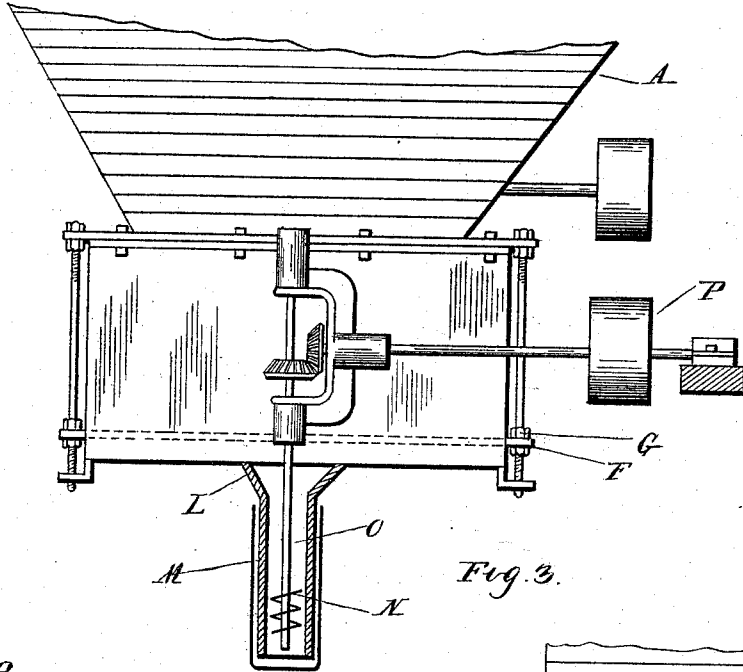
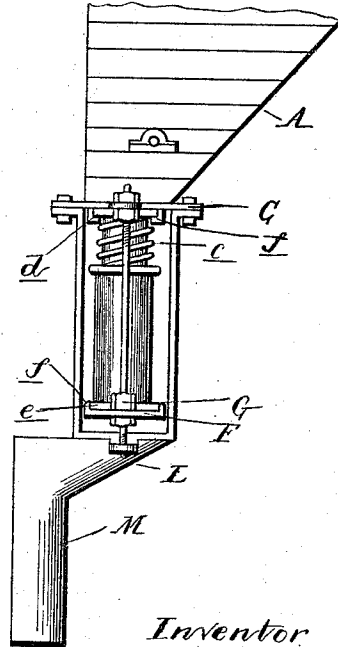
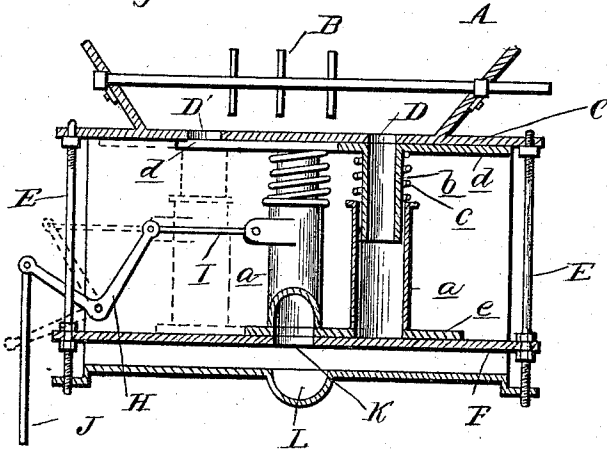

Fig. 3.

Fig. 2.



Witnesses
a. L. Kobbie
P. M. Hulbert

Inventor
Thomas Craney
By *Maxwell Maguire*
Attys.

UNITED STATES PATENT OFFICE.

THOMAS CRANEY, OF BAY CITY, MICHIGAN.

BAG-FILLER.

SPECIFICATION forming part of Letters Patent No. 470,475, dated March 8, 1892.

Application filed April 15, 1891. Serial No. 389,107. (No model.)

To all whom it may concern:

Be it known that I, THOMAS CRANEY, a citizen of the United States, residing at Bay City, in the county of Bay and State of Michigan, have invented certain new and useful Improvements in Bag-Fillers, of which the following is a specification, reference being had therein to the accompanying drawings.

This invention relates to new and useful improvements in bag-fillers, designed especially for use in filling such articles as salt, sugar, flour, &c., into bags.

The invention consists in the peculiar construction of a transfer-tube arranged between the feed-opening and the discharge-opening and having suitable means for connecting said tube alternately with the feed and discharge openings, whereby it is alternately filled and emptied.

The invention further consists in the peculiar construction of this tube and its supporting-frame, whereby it may be made to deliver a given quantity or weight of the article to be fed into the bags.

The invention further consists in the peculiar construction of the various parts, as more fully hereinafter described.

In the drawings, Figure 1 is a side elevation of my improved machine. Fig. 2 is a vertical central section thereof, and Fig. 3 is an end elevation thereof.

A is a hopper into which the material designed to be bagged is placed, and, if required, a suitable stirrer B may be placed near the bottom thereof.

C is a plate arranged across the bottom of the hopper and provided with the apertures D D'; through which the material is to be fed. Suspended from this frame by means of the rods E is a second plate F, which I preferably make adjustable to and from the plate C by means of the lock-nuts G, engaged on the rod E upon both sides of the plate F. Between the plates C and F is my transfer tube or tubes. In the accompanying drawings I have shown two of such tubes; but it is evident that a single one may be used where the material will not run sufficiently fast to allow of rapid handling. Each of these tubes is preferably of the following construction: *a b* are tubular telescopic sections engaged one within the other and held in their adjustable

position by means of a spring *c*, which tightly presses the ends against the upper and lower plates. The upper section is provided with a lateral extension *d*. The lower section *a* is provided with a flange *e*, and both of the upper and lower flanges engage in suitable guides *f*.

In using two tubes, as shown in the drawings, I connect the flanged guide to hold these tubes at a fixed distance apart, so that one actuating mechanism will move them both. Any means may be employed for reciprocating said tubes, or if the tubes are stationary they reciprocate the plates C and F.

The means which I have shown for reciprocating the tubes consists of the bell-crank lever H, the connecting-rod I, and the connecting-rod J, the rod I being connected to the tubes, the bell-crank lever pivoted in the frame, and the rod J pivoted to any suitable source of power.

K is a discharge-aperture through the plate F, arranged between the apertures D D' and connected by means of a chute L with a packing-cylinder or discharge-spout. The bag is designed to be placed over this discharge-aperture and to be filled by means of a worm N upon the shaft O, passing centrally through this discharge-spout and driven from the pulley P and suitable connecting-gears.

It is evident that the material in the hopper will feed through the aperture D into the transfer-tube when that tube is beneath the opening, and when the tube is reciprocated to the left the flange *d* will cover the aperture D, and as soon as the lower end of the tube registers with the aperture K the material will fall therefrom into the chute L and be packed into the bag by means of the worm in the discharge-spout M. While this tube is discharging, the other tube will be filling through the aperture D'. When the tubes are reciprocated in the reverse direction, the same result will be obtained.

What I claim as my invention is—

1. In a bag-filler, the combination, with a frame having a stationary apertured upper plate, of a vertically-adjustable bottom plate having an aperture therein, vertically-adjustable and longitudinally-movable tubes between the plates, and means for adjusting the tubes, substantially as described.

2. In a bag-filler, the combination, with a frame having a stationary apertured upper plate, of a bottom plate suspended from the upper plate, means for adjusting the bottom plate vertically, and an adjustable transfer-tube on the bottom plate, substantially as described.

3. In a bag-filler, the combination, with a frame having a stationary upper plate, of rods secured to the upper plate, a lower plate through which the rods pass, nuts on the rod below the lower plate, vertically-adjustable and longitudinally-movable transfer-tubes between the plates, and a lever for moving the tubes longitudinally, substantially as described.

4. In a bag-filler, the combination, with a frame having a stationary upper plate, of a lower plate, a transfer-tube arranged between the plates, provided with a lateral extension on its upper end and a flange on its lower end, and means for moving the tube horizontally, substantially as described.

5. In a bag-filler, the combination, with a frame having a stationary upper plate, of a vertically-adjustable lower plate centrally perforated, adjustable transfer-tubes slidingly secured between the plates, cut-off extensions on the tubes, and a lever for moving the tubes, substantially as described.

6. In a bag-filler, the combination of the frame, the tube composed of telescopic sections *a b* and spring *c*, and means for reciprocating the tube, substantially as described.

7. In a bag-filler, the combination of the frame consisting of the plates adjustable in relation to each other and a transfer-tube between and consisting of the two telescopic sections *a b*, spring *c*, and flange *d*, substantially as described.

In testimony whereof I affix my signature in presence of two witnesses.

THOMAS CRANEY.

Witnesses:

M. B. O'DOHERTY,
N. L. LINDOP.