

L. G. Clock,

Earth Closet.

No. 104,270.

Patented June 14, 1870.

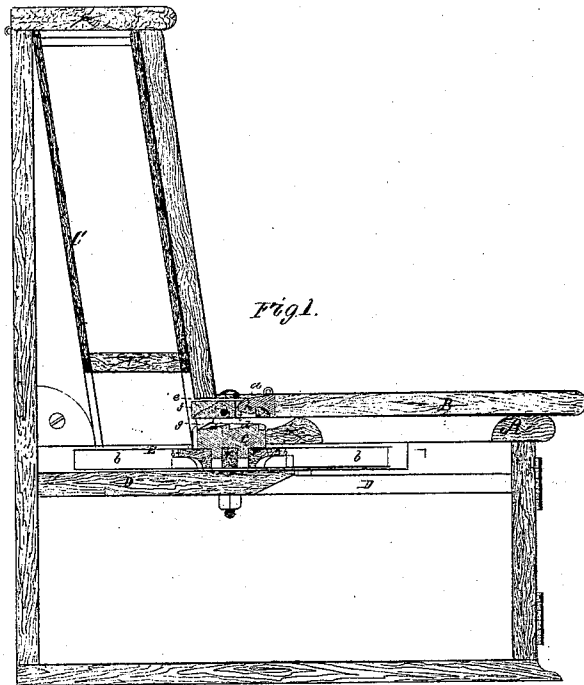

Fig. 1.

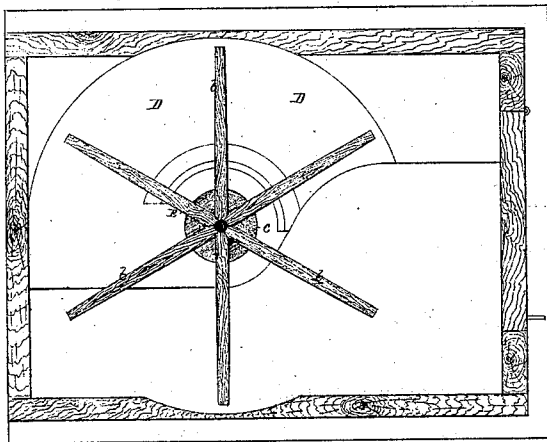

Fig. 2.

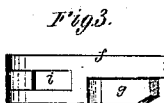

Fig. 3.

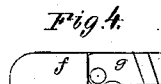

Fig. 4.

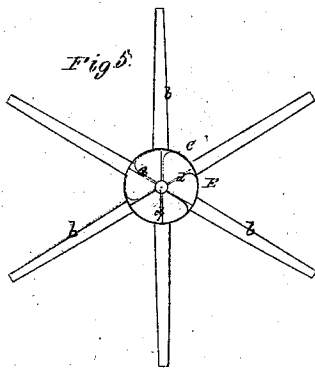

Fig. 5.

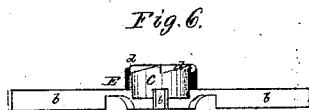

Fig. 6.

Witnesses

L. N. Piper

L. N. Miller

Lewis G. Clock

his attorney

R. H. Eady

United States Patent Office.

LEWIS G. CLOCK, OF MANCHESTER, NEW HAMPSHIRE.

Letters Patent No. 104,270, dated June 14, 1870.

IMPROVEMENT IN EARTH-CLOSETS.

The Schedule referred to in these Letters Patent and making part of the same

To all persons to whom these presents may come:

Be it known that I, LEWIS G. CLOCK, of Manchester, of the county of Hillsborough and State of New Hampshire, have invented a new and useful Improvement in Earth-Closets; and do hereby declare the same to be fully described in the following specification and represented in the accompanying drawing, of which—

Figure 1 is a vertical section, and

Figure 2, a horizontal section of an "earth-closet" with my invention applied thereto, such invention consisting in a peculiar mechanism for discharging into the hod, or excrement receptacle, earth from the hopper.

In the drawing—

A denotes the seat;

B, the lid or cover thereof, the said cover being hinged to a stationary cleat, *a*.

In rear of and above the seat is the hopper or earth-reservoir C, which, at bottom, is open, so as to discharge upon a platform, D, arranged below the hopper and seat, and in rear and aside of such seat.

On the said platform is a discharger, E, composed of a series of arms, *b b*, extending radially and at equal distances apart from a horizontal ratchet, *c*, having teeth arranged on its upper side.

Figure 3 is a top view, and

Figure 4, a side view of such discharger, the teeth of its ratchet being shown at *d*.

There is arranged on the seat, and so as to play through an opening, *e*, made in the cleat, a slider, *f*, which has pivoted to it a pawl, *g*, to operate against the teeth of the ratchet.

Furthermore, there is a short arm or tooth, *h*, projected from the rear edge of the seat and into an opening, *i*, made in the slider *f*.

Figure 5 is a top view of the slider and its pawl.

Figure 6 being a side view of them.

On raising the cover from off the seat, the tooth will move the slider toward the hole of the seat, and thereby draw the pawl back on the ratchet; but, while the cover is being depressed, the tooth will move the slider and advance the pawl against the ratchet, so as to turn it through a part of a circle, whereby the discharger will be caused to force off the platform and into the hod or excrement receptacle under the seat, a quantity of earth.

The discharger, by its peculiar construction, and its arrangement with the hopper and platform, will prevent unnecessary waste or escape of earth from the hopper.

The arms of the discharger should be arranged at such distances apart that neither of them shall be directly underneath the seat-hole when the cover is raised to its highest position, or when a person may be sitting on the seat.

I claim as my invention—

The discharger E and its operative mechanism, viz., the tooth *h*, the slider *f*, the pawl *g*, and ratchet *c*, combined with the hopper C, the platform D, the seat A, and its cover B, the whole being substantially as and to operate as specified.

LEWIS G. CLOCK.

Witnesses:

R. H. EDDY,
J. R. SNOW.