

(No Model.)

G. C. GOWEN.  
BINDER FOR SHEET MUSIC, &c.

No. 405,254.

Patented June 18, 1889.

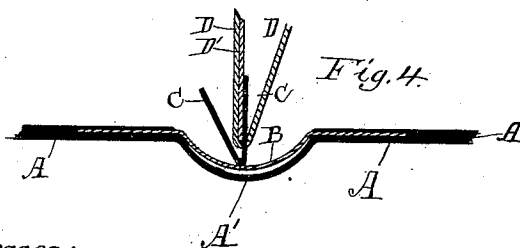
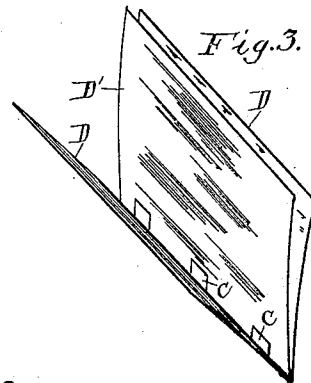
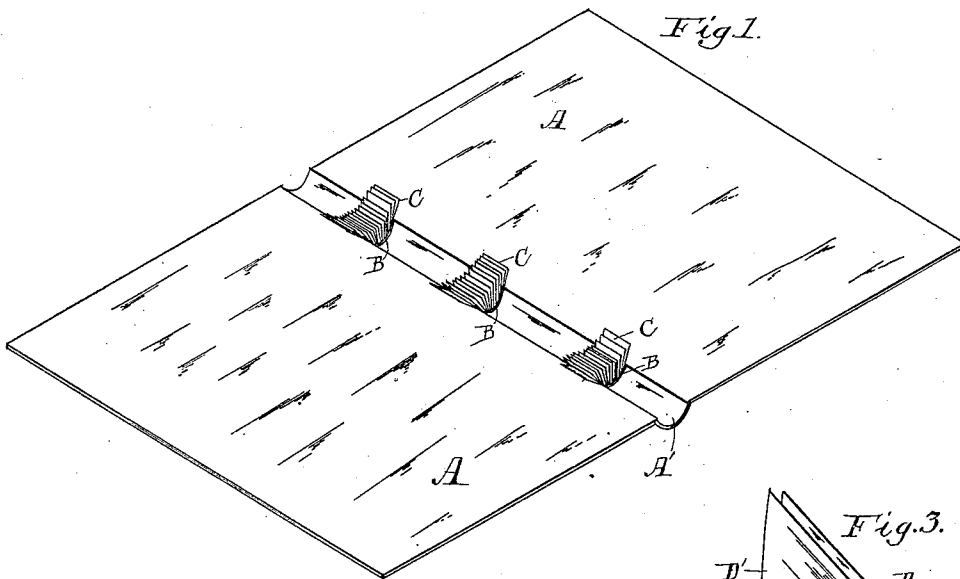
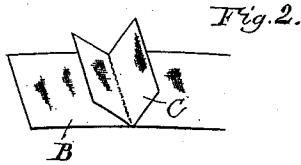

Witnesses:  
Walter F. Hunt,  
Robert A. Davis,

Inventor:  
George C. Gowen  
by S. M. Bates  
his atty.

# UNITED STATES PATENT OFFICE.

GEORGE C. GOWEN, OF PORTLAND, MAINE.

## BINDER FOR SHEET-MUSIC, &c.

SPECIFICATION forming part of Letters Patent No. 405,254, dated June 18, 1889.

Application filed April 18, 1888. Serial No. 271,061. (No model.)

*To all whom it may concern:*

Be it known that I, GEORGE C. GOWEN, a citizen of the United States, residing at Portland, in the county of Cumberland and State of Maine, have invented certain new and useful Improvements in Binders for Sheet-Music, &c.; and I do hereby declare the following to be a full, clear, and exact description of the invention, such as will enable others skilled in the art to which it appertains to make and use the same.

My invention relates to binders for sheet-music, newspapers, pamphlets, &c.; and its object is to produce a binder which shall serve at the same time as a temporary and a permanent binder, by means of which music, periodicals, &c., can be easily bound up as received, forming a permanent volume when the binder is full.

Many temporary binders have hitherto been constructed having in view the same end as in my invention. The most common form of binder heretofore used has consisted of a number of strips bound up together and having their surfaces coated with mucilage, the sheets to be bound being attached or stuck to these strips. This binder was obviously adapted only to securing single sheets or single folios.

The particular aim of my invention is to securely bind sheet-music and other similar forms where there is more than one sheet in each piece, and especially where there is a detached half-sheet, as in many cases, although it is equally well adapted for single sheets.

The invention consists of the combinations of devices, as hereinafter set forth in the claims.

I illustrate my invention by means of the accompanying drawings, in which—

Figure 1 is a perspective view of my binder in one of its forms before any sheets are bound or pasted in. Fig. 2 is a perspective view of the strip with a single tab attached. Fig. 3 is a view of a single sheet and half-sheet as bound. Fig. 4 is a section showing the manner of binding a sheet and half-sheet.

A A are two covers united by the usual back piece A'. Several strips, (in this case three,) as B, made, preferably, of stout cloth, are se-

cured by their ends to the adjacent edges of the covers A A. I usually accomplish this by gluing these ends within the folds of the cover, having the ends run well back, as shown in Fig. 4. To each of these strips I secure a number of pieces C of stout material—such as linen or other cloth—and which I shall denominate “tabs.” These pieces I prefer to make double the length which I wish the separate tabs to be, fastening them to the strip B by sewing through and through. One side of each of these tabs is coated with a suitable adhesive substance, such as “dextrine,” which I have found to be most useful for this purpose.

If the paper to be bound is a single sheet or folio, or a half-sheet, the tabs are simply moistened and stuck to the side of it. If the article to be bound contains more than one sheet, the sheets are placed one inside the other, in the usual way, and incisions or apertures are made in the folded edges, passing through all the sheets. The tabs are then inserted in these incisions and then are stuck to the inner sheet. This inner sheet may be a half-sheet, in which case the tabs are stuck on one side of it, or it may be a full sheet. If it should be a sheet with a double-page picture—such as is found in pictorial papers—the tabs are secured to the outside, so that when opened it presents a plain surface. The sheets thus bound up will remain in place without cramping, and can be laid open flat, where they will remain in position, as their back edges are not compressed. So long as the central sheet remains stuck to the tabs the whole will remain solidly in place.

If desired, the outside covers may be dispensed with and the tabs used alone for a temporary binder. In such case its application will be the same as where it is used with the covers.

A single set of tabs may be used in place of three sets, as here shown, by making them of sufficient length.

I claim—

1. In a binder for sheet-music and other like articles, the combination of two outer covers united by a back piece of ordinary construction, a flexible strip secured by its ends to the adjacent edges of said cover, and

95

100

a number of tabs or pieces of cloth or other like material secured to said strip and coated with adhesive material, said tabs being shorter than said back piece, whereby they may be  
5 passed through incisions in the edges of the leaves to be bound, substantially as and for the purpose set forth.

2. A book or volume composed of sheets in sets of two or more folded one inside of the  
10 other, a pair of covers united by a back piece, one or more flexible strips secured by their

ends to the adjacent edges of said cover, tabs shorter than said back piece secured to said strips and to the inner sheet of each set, and apertures in the folded edges of said sheets to  
15 admit said tabs, substantially as shown.

In testimony whereof I affix my signature in presence of two witnesses.

GEORGE C. GOWEN.

Witnesses:

S. W. BATES,

W. A. TURNER.