

C. W. SMITH.  
 SLIDE VALVE ADJUSTER.  
 APPLICATION FILED JAN. 7, 1911.

997,098.

Patented July 4, 1911.

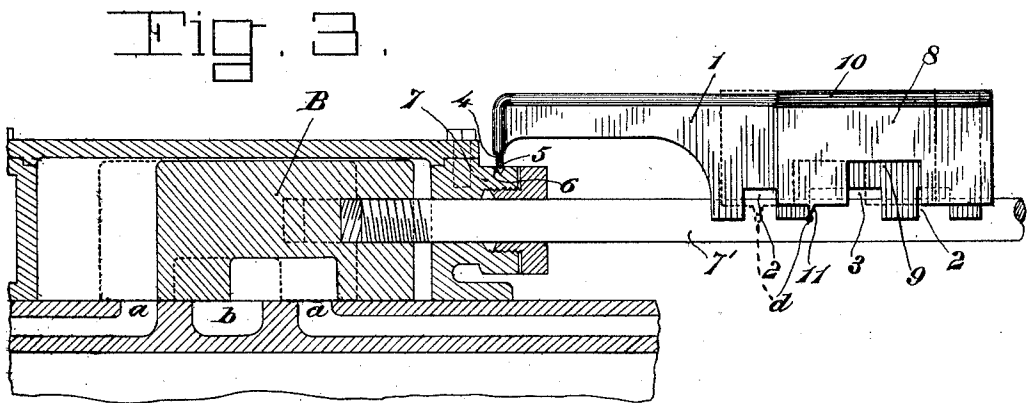
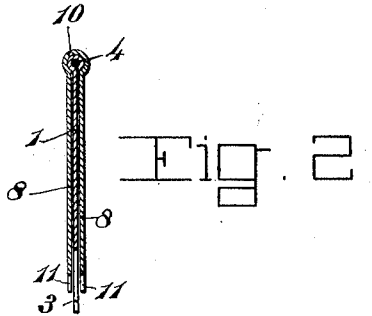
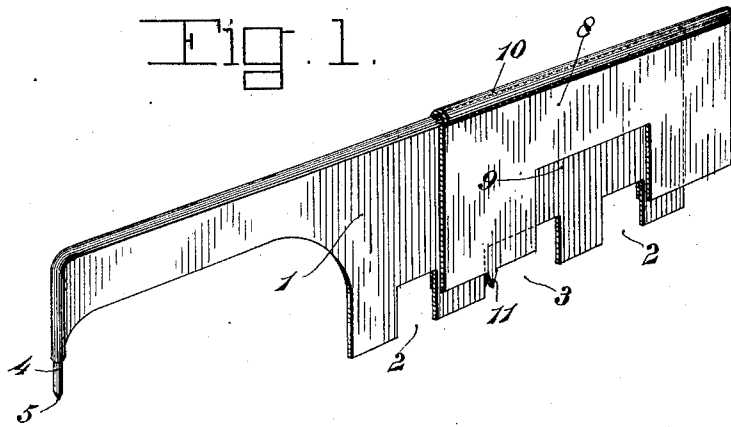

Inventor  
 Charles W. Smith

Witnesses  
 Harry King  
 W. M. ...

By Victor J. Evans  
 Attorney

# UNITED STATES PATENT OFFICE.

CHARLES W. SMITH, OF DEEPWATER, MISSOURI, ASSIGNOR OF ONE-FOURTH TO EMORY E. DE ARMOND AND ONE-FOURTH TO ALVIN M. DE ARMOND, OF DEEPWATER, MISSOURI.

## SLIDE-VALVE ADJUSTER.

997,098.

Specification of Letters Patent.

Patented July 4, 1911.

Application filed January 7, 1911. Serial No. 601,289.

*To all whom it may concern:*

Be it known that I, CHARLES W. SMITH, a citizen of the United States, residing at Deepwater, in the county of Henry and State of Missouri, have invented new and useful Improvements in Slide-Valve Adjusters, of which the following is a specification.

This invention relates to an instrument whereby the slide valve of a reciprocating engine, compressor or the like can be quickly and accurately adjusted without the necessity of removing the plate of the steam chest for access to the valve.

The invention has for one of its objects to provide an instrument of this character which is of comparatively simple and inexpensive construction, reliable and efficient in use, and readily manipulated.

Another object of the invention is the provision of an instrument that is adapted to be placed in fixed position with respect to the steam chest and valve rod so that, by means of a mark on the latter, the instrument can be used to ascertain the position of the slide valve or the extent to which it is out of adjustment and the proper adjustment of the valve mechanism can be made, such proper adjustment being tested by the instrument.

With these objects in view and others, as will appear as the description proceeds, the invention comprises the various novel features of construction and arrangement of parts which will be more fully described hereinafter and set forth with particularity in the claims appended hereto.

In the accompanying drawing, which illustrates one embodiment of the invention, Figure 1 is a perspective view of the device. Fig. 2 is a transverse section thereof. Fig. 3 is a diagrammatic view of a steam chest and slide valve showing the manner of placing the instrument for testing the adjustment of the valve and for facilitating the proper adjustment thereof.

Similar reference characters are employed to designate corresponding parts throughout the views.

Referring to the drawing, 1 designates a plate which at its bottom edge is provided with end recesses 2 and a middle recess 3 which correspond in shape and relative location to the inlet and exhaust ports *a* and *b* of the engine, shown in Fig. 3. This plate

may be made of sheet metal and reinforced at its upper longitudinal edge by a rod 4 around which the metal is curled, and at one end the rod is bent downwardly to form a point or finger 5 which is adapted to be entered in a recess 6 pricked by means of a punch in the packing box 7 or other suitable fixed part of the steam chest. This plate 1 is intended to be held stationary during the use of the instrument with the recessed lower edge placed against one side of the valve rod 7'.

Mounted on the plate 1 is a slide 8 which corresponds to the slide valve B of the engine, the said slide 8 having a recess 9 corresponding to the chamber of the slide valve. The slide 8 consists of a piece of sheet metal which is doubled over the plate 1 and at the doubled portion is formed a bead 10 that fits the bead at the top of the plate 1. At a suitable point on the bottom edge of the slide 8 is a pointer 11 by which the position of the valve can be ascertained with respect to a hole *d* pricked in the side of the valve rod. In order to locate the position of the hole *d*, the valve chest plate is taken off and the valve slide centrally positioned in the chest, as shown by dotted lines in Fig. 3, and after placing the valve adjuster in proper position, the slide thereof is adjusted to the position indicated by dotted lines. The dot *d* is punched in the rod in line with the point 11 of the slide. After the rod is thus marked, the valve adjuster can be used at any subsequent time to determine the position of the valve and whether adjustment is necessary. Whenever the valve is out of proper adjustment, this can be ascertained by adjusting the slide 8 so that the point 11 will come opposite the dot *d*, and the distance between the point 11 and the middle of the left hand recess 2 will show the extent to which the valve gearing must be adjusted to restore the valve to proper position.

From the foregoing description, taken in connection with the accompanying drawings, the advantages of the construction and of the method of operation will be readily apparent to those skilled in the art to which the invention appertains, and while I have described the principle of operation of the invention, together with the device which I now consider to be the best embodiment thereof, I desire to have it understood

that the apparatus shown is merely illustrative, and that such changes may be made when desired as are within the scope of the claims appended hereto.

5 Having thus described the invention, what I claim as new, is:—

1. An instrument of the class described comprising a plate having recesses corresponding to the ports of an engine, a slide 10 thereon correspondingly shaped to a slide valve and arranged to move across the said recesses, and means on the plate for attaching the same to a fixed part of the engine while the recessed portion of the plate will 15 be disposed adjacent the valve rod.

2. An instrument of the class described comprising a plate having cutaway portions corresponding to the ports of an engine, a slide movable longitudinally of the plate 20 and corresponding in shape to the section of the slide valve, a member on one end of the plate for attaching the same to a fixed part of an engine while the recessed portion

of the plate is held against the valve rod, and a point on the bottom edge of the slide 25 adapted to be moved opposite to a point of the valve rod to ascertain the position of the valve when the piston of the engine is in a predetermined position.

3. An instrument of the class described 30 comprising a plate having recesses at its bottom edges corresponding to the ports of an engine, a slide doubled over the top edge of the plate and representing the slide valve 35 in its proper relation to the said ports, and means on one end of the plate for holding the same fixed with respect to the steam chest of an engine while the recessed portion 40 of the plate bears against the valve rod.

In testimony whereof I affix my signature 40 in presence of two witnesses.

CHARLES W. SMITH.

Witnesses:

W. E. BAILEY,  
WILSON SMITH.

Copies of this patent may be obtained for five cents each, by addressing the "Commissioner of Patents, Washington, D. C."