

May 30, 1967

W. R. BOOK

3,323,100

ELECTRICAL CONNECTOR

Filed May 26, 1965

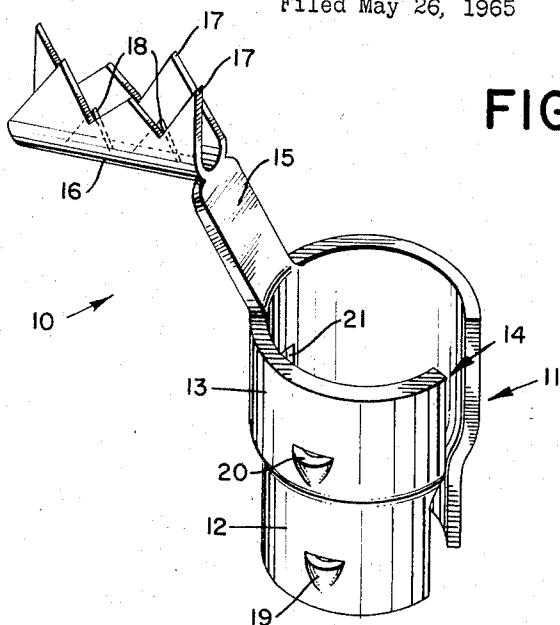

FIG. 1

FIG. 3

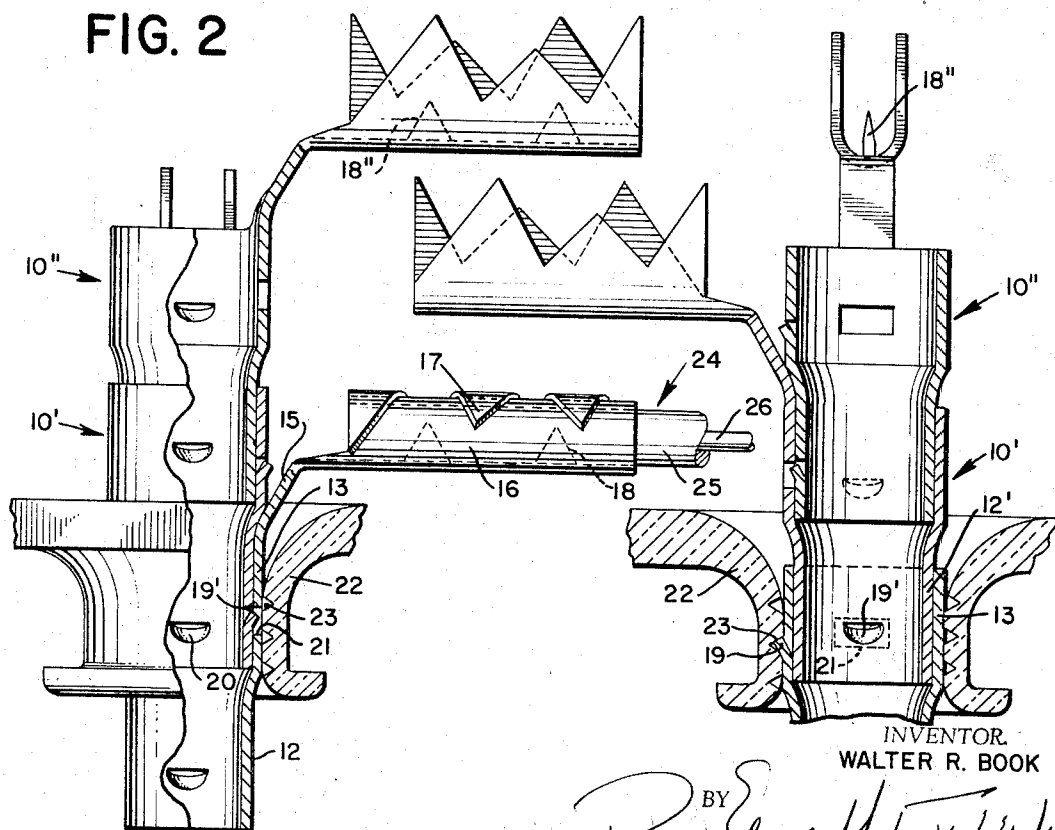

FIG. 2

INVENTOR  
WALTER R. BOOK

BY *Pennic, Edmunds, Martin, Taylor & Allen*  
ATTORNEYS

1

3,323,100

**ELECTRICAL CONNECTOR**

Walter R. Book, Bethlehem, Conn., assignor to Anaconda American Brass Company, a corporation of Connecticut  
 Filed May 26, 1965, Ser. No. 459,041  
 3 Claims. (Cl. 339-242)

This invention relates to an electrical connector. More particularly, it relates to an electrical connector which is configured to permit a plurality of connectors to be interconnected in a tandem-type arrangement so that a plurality of electrical wires can be electrically connected into a single electrical socket.

Electrical panel boards into which numerous wires are connected are commonly designed with a plurality of sockets defined by an eyelet which is crimped over in the panel board and subsequently threaded. Wires were connected to these sockets by bending the wire about a screw which was then inserted into the eyelet and tightened to hold the wires in place to make the connection. It is common practice to attach several wires to the same socket by bending a loop in each wire, inserting the screw into the loop, adding washers, separating the wires and tightening the wires by means of the screw.

I have developed a new electrical connector which can be used in combination with panel boards of the type having threaded eyelets as sockets and is configured to permit the connector to simply be forced into the threaded eyelet and held in this position by its configuration. Broadly stated, the electrical connector is comprised of a generally tubular member having a longitudinal slot therein. The tubular member is defined by a male portion at one end having a first diameter and integral female portion at the other end of the member having a second diameter larger than the first diameter. Lug means are provided on the male portion and are extended radially outward for locking engagement with a female portion of another connector. Lug receiving means are provided in the female portion for receiving the lug means of another connector and holding the two connectors in locking engagement. A laterally extending wire attachment portion extends from the female portion for holding the end of a wire attached to it. By using electrical connectors a plurality of connectors can be interconnected in a tandem arrangement and a plurality of wires can be electrically connected to a single electrical socket. The electrical connector also preferably has a lug extending radially outward from the female portion so that the first connector used in the tandem-type arrangement, which is inserted in the socket of the panel, will be held fixed within the threaded eyelet. The wire attachment portion is preferably an integral narrow strip which extends from the female end of the connector and is bent laterally outward with an electrical wire attachment portion at the end of the flange portion.

A preferred embodiment of the invention with reference to the drawing wherein:

FIG. 1 is a perspective of an electrical connector of the invention;

FIG. 2 is an elevation partly in section of a tandem-type arrangement of three interconnected electrical connectors; and

FIG. 3 is a section of the tandem arrangement of FIG. 2 as viewed 90° offset in a clockwise direction from that shown in FIG. 2.

The electrical connector 10 consists of a unitary strip of copper or a copper alloy or any other metal which is a good electrical conductor. The strip is formed into a stepped diameter generally cylindrical member 11 with a male portion 12 defined by the smallest diameter portion of the member at one end thereof and a female portion 13

2

at the other end defined by the largest diameter portion of the cylindrical member. A longitudinal slot 14 is defined in the member 11 by a separation between the sides of the strip, and this split in the continuity of the cylindrical shape permits reducing and enlarging the diameter of the connector somewhat. An integral narrow strip portion 15 extends from the endmost portion of the female portion 13 laterally outward therefrom and has a generally U-shaped sleeve portion 16 at the marginal portion of the strip 15 into which a wire is placed for attachment. Preferably the sides of the U-shaped sleeve have serrations 17 formed therein with the serrations on one side offset from serrations cut on the opposite side so that the serrated side edges of the sleeve will substantially interlock when the sides of the sleeve are crimped about the end of the wire. Preferably positioned in the middle of the U-shaped sleeve are sharp projections 18 which are designed to pierce the insulation of an insulated wire conductor and make contact with the conductor itself. Of course an electrical conductor can be soldered to the strip if the crimpable sleeve is not provided.

A portion of the side wall of the cylindrical member is punched radially outward in the male portion 12 so as to define a lug 19. A similar second lug 20 was punched radially outward in the female portion 13. The female portion 13 also has an opening 21 cut into the wall of the cylindrical member; the opening is of a size suitable for receiving a lug of a male portion of a second similar connector. It is to be noted that the cylindrical member 11 has an axial bore extending therethrough with a stepped diameter so that the inside diameter of the female portion 13 is of a diameter to receive the male portion 12. Thus, a plurality of these connectors 10 can be interconnected in a tandem-type arrangement as shown in FIGS. 2 and 3.

The first connector is inserted into a threaded eyelet 22 positioned on a panel board by simply pushing it throughout the eyelet until lug 20 on the female portion locks into one of its threads 23 to prevent axial displacement from the eyelet. An electrical wire 24 having an insulating sheath 25 formed about an electrical conductor 26 is then inserted into the U-shaped sleeve 16 which is then crimped about the electrical wire so that the projections 18 pierce throughout the sleeve and make good electrical contact with the electrical conductor 26. A second electrical connector 10' can then be inserted into the first electrical connector by pushing the male portion 12' into the female portion 13' of the first electrical connector and rotating it so that lug 19' becomes inserted into the opening 21 so as to lock the two connectors against axial displacement relative to each other. A third electrical connector 10'' can then be similarly inserted into the second connector and thereby build up a plurality of connectors in a tandem-like arrangement.

It is to be noted that the lug 19 is circumferentially offset 90° from the opening 21 and the narrow strip 15 is in substantial axial alignment with the opening 21. By this means the successive tandem arrangement of a plurality of electrical connectors will also position the wire attachment strip 15 so that it extends circumferentially offset from the preceding and succeeding interconnected electrical connectors. Of course a plurality of openings 21 and a plurality of lugs 19 could be positioned at circumferentially spaced intervals about the connector to give more variety in positioning of the wire attachment strips when connecting a plurality of connectors together.

Since the connector described is formed from a unitary metal strip, an additional advantage can be realized by supplying the connectors in a continuous strip so that for factory insulation in panels they can be cut off automatically as used. This can be done with the connector in the configuration shown in the drawings or the strip

3

could be cut into the proper shape but bent into its desired configuration by a machine at the place of use.

I claim:

1. An electrical connector for interconnection with a plurality of similar connectors in a tandem-type arrangement so that a plurality of wires can be electrically connected to a single electric socket comprising a generally tubular member having a longitudinal slot therein, a male portion of said tubular member at one end having a first diameter, an integral female portion at the other end of said member having a second diameter larger than said first diameter, an axial bore defined in said member having a stepped diameter with the inside diameter of the bore in the female portion of sufficient diameter to receive a male portion of a second similar connector, a laterally extending wire attachment portion extending from the free end of said female portion, lug means on said male portion extending radially outward therefrom for locking engagement with a female portion of another connector and lug receiving means in said female portion circumferentially offset from said lug means on said male portion for holding two similar connectors together in locking engagement with the wire attachment portions of joined connectors circumferentially offset from each other.

2. An electrical connector according to claim 1 wherein said wire attachment portion is an integral narrow strip extending laterally outward from the endmost portion of

4

the female portion with a sleeve defined at its marginal end for holding an electrical wire in electrical contact therewith.

3. An electrical connector according to claim 2 wherein said lug and lug receiving means comprise at least one radially projecting lug extending from the side of the male portion, at least one slot in said female portion positioned circumferentially offset from said lug for receiving a lug of a second similar connector and preventing axial and circumferential displacement of the joined connectors relative to each other, and at least one radially projecting lug extending from the side of the female portion for locking engagement with an electrical socket.

#### References Cited

##### UNITED STATES PATENTS

1,687,574	10/1928	Liss.	
2,533,343	12/1950	Bac	339—259
3,146,051	8/1964	Woofter et al.	339—258 X
3,189,869	6/1965	Avery	339—258

##### FOREIGN PATENTS

1,145,821	5/1957	France.
514,965	2/1955	Italy.

MARVIN A. CHAMPION, *Primary Examiner.*

P. TEITELBAUM, *Assistant Examiner.*