



- (51) International Patent Classification:
F01D 25/24 (2006.01) *F01D 25/26* (2006.01)
- (21) International Application Number:
PCT/US2013/038464
- (22) International Filing Date:
26 April 2013 (26.04.2013)
- (25) Filing Language: English
- (26) Publication Language: English
- (30) Priority Data:
61/639,563 27 April 2012 (27.04.2012) US
- (71) Applicant: **GENERAL ELECTRIC COMPANY**
[US/US]; 1 River Road, Schenectady, NY 12345 (US).
- (72) Inventors: **DREISCHARF, Derek, Thomas**; 6380 Aviation Way, West Chester, OH (US). **PEGAN, JR., Courtland, Earl**; 6380 Aviation Way, West Chester, OH (US). **RYCZEK, Scott, Patrick**; 1 Neumann Way, Cincinnati, OH (US).

- (74) Agents: **DOMBROWSKI, Joanna, M.** et al.; General Electric Company, Global Patent Operation, 2 Corporate Drive, Suite 648, Shelton, CT 06484 (US).
- (81) Designated States (*unless otherwise indicated, for every kind of national protection available*): AE, AG, AL, AM, AO, AT, AU, AZ, BA, BB, BG, BH, BN, BR, BW, BY, BZ, CA, CH, CL, CN, CO, CR, CU, CZ, DE, DK, DM, DO, DZ, EC, EE, EG, ES, FI, GB, GD, GE, GH, GM, GT, HN, HR, HU, ID, IL, IN, IS, JP, KE, KG, KM, KN, KP, KR, KZ, LA, LC, LK, LR, LS, LT, LU, LY, MA, MD, ME, MG, MK, MN, MW, MX, MY, MZ, NA, NG, NI, NO, NZ, OM, PA, PE, PG, PH, PL, PT, QA, RO, RS, RU, RW, SC, SD, SE, SG, SK, SL, SM, ST, SV, SY, TH, TJ, TM, TN, TR, TT, TZ, UA, UG, US, UZ, VC, VN, ZA, ZM, ZW.
- (84) Designated States (*unless otherwise indicated, for every kind of regional protection available*): ARIPO (BW, GH, GM, KE, LR, LS, MW, MZ, NA, RW, SD, SL, SZ, TZ, UG, ZM, ZW), Eurasian (AM, AZ, BY, KG, KZ, RU, TJ, TM), European (AL, AT, BE, BG, CH, CY, CZ, DE, DK, EE, ES, FI, FR, GB, GR, HR, HU, IE, IS, IT, LT, LU, LV, MC, MK, MT, NL, NO, PL, PT, RO, RS, SE, SI, SK, SM,

[Continued on next page]

(54) Title: SYSTEM AND METHOD OF LIMITING AXIAL MOVEMENT BETWEEN A HANGER AND A FAIRING ASSEMBLY IN A TURBINE ASSEMBLY

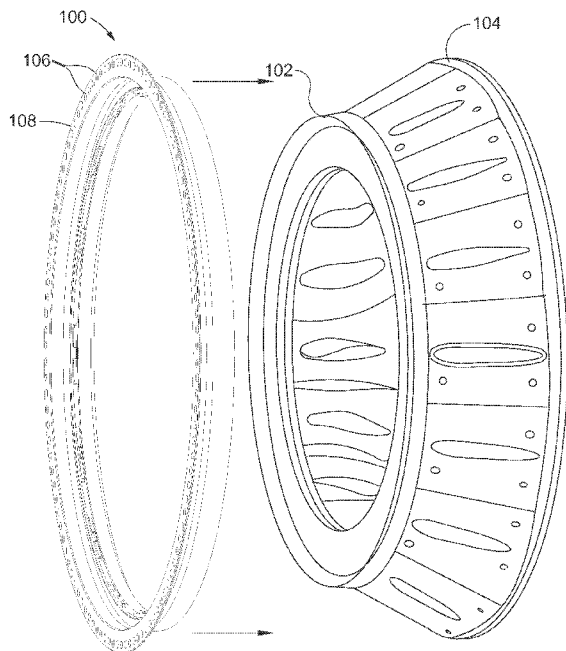

FIG. 1

(57) Abstract: A system for use in limiting axial movement between a hanger and a fairing assembly within a turbine assembly is provided. The hanger includes an inner radial hanger bend portion that defines a hook channel therein. The fairing assembly includes an outer surface, a hook member extending from the outer surface to mate with the hook channel, and a circumferential groove defined in the outer surface such that at least a portion of the hanger bend portion is positioned between the circumferential groove and the hook member. The system includes a retention member sized for insertion into the circumferential groove, wherein the retention member is configured to extend from the circumferential groove and press against the hanger bend portion to facilitate maintaining the hook member within the hook channel.





TR), OAPI (BF, BJ, CF, CG, CI, CM, GA, GN, GQ, GW, ML, MR, NE, SN, TD, TG).

— *before the expiration of the time limit for amending the claims and to be republished in the event of receipt of amendments (Rule 48.2(h))*

Published:

— *with international search report (Art. 21(3))*

SYSTEM AND METHOD OF LIMITING AXIAL MOVEMENT BETWEEN A HANGER AND A FAIRING ASSEMBLY IN A TURBINE ASSEMBLY

CROSS-REFERENCE TO RELATED APPLICATIONS

[0001] This application is a non-provisional application and claims priority to U.S. Provisional Patent Application Serial No. 61/639,563 filed April 27, 2012 for “TURBINE FRAME HANGER LOCK ASSEMBLY AND METHOD”, which is hereby incorporated by reference in its entirety.

BACKGROUND OF THE INVENTION

[0002] This invention relates generally to gas turbine engines, and more specifically to turbine frame hanger lock assemblies and methods of assembling the same.

[0003] At least some known gas turbine engines include a frame that supports a rotor assembly. For example, gas turbine engines may include one or more rotor shafts supported by bearings which, in turn, may be supported by generally annular engine frames. An engine frame may include a generally annular casing spaced radially outwardly from an annular hub, with a plurality of circumferentially spaced apart struts extending therebetween. In some frame applications it may be necessary to protect the struts with fairings that have higher temperature capability. Because temperature variances can cause metals to expand and contract, it is desirable to separate high temperature engine components such as the flow path components, from comparatively low temperature peripheral components such as the frame components. To attach flow path components to the frame components, one or more hangers are used. The hangers serve to attenuate heat transfer from flow path components to frame components. Primarily, these hangers serve to affix flow path components in predetermined positions relative to frame components.

[0004] In some implementations, hangers are annular components with a curved cross-section. The outermost surface of the hangers contain apertures and are fastened (e.g., with bolts threaded through the apertures) to the frame of the turbine engine. The innermost surface of the hangers can be fastened to the flow path components, also utilizing apertures for receiving fasteners (e.g., bolts). In some cases, a single hanger may be used to attach a single flow path component to a frame component. In other cases, a single hanger may be used to attach multiple flow path components to a frame component. Each hanger conventionally requires a number of fasteners, adding a significant time burden to installation. Furthermore, the number of hangers and corresponding large quantity of fasteners contribute to the overall weight of the turbine engine. Even further, the use of bolts to attach hangers to various flow path and frame components inherently requires penetration of both the hangers and the respective components, increasing the potential for stress related failures in the gas turbine engine.

BRIEF DESCRIPTION OF THE INVENTION

[0005] In one aspect, a system for use in limiting axial movement between a hanger and a fairing assembly within a turbine assembly is provided. The hanger includes an inner radial hanger bend portion that defines a hook channel therein. The fairing assembly includes an outer surface, a hook member extending from the outer surface to mate with the hook channel, and a circumferential groove defined in the outer surface such that at least a portion of the hanger bend portion is positioned between the circumferential groove and the hook member. The system includes a retention member sized for insertion into the circumferential groove, wherein the retention member is configured to extend from the circumferential groove and press against the hanger bend portion to facilitate maintaining the hook member within the hook channel.

[0006] In another aspect, a turbine assembly is provided. The turbine assembly includes a hanger including an inner radial hanger bend portion that defines a hook channel therein and a fairing including an outer surface, a hook member extending from said outer surface to mate with said hook channel, and a groove

defined in said outer surface such that a portion of said hanger bend portion is positioned between said groove and said hook member. The assembly also includes a retention member sized for insertion into said groove, wherein said retention member is configured to extend from said groove and press against said hanger bend portion to facilitate maintaining said hook member within said hook channel.

[0007] In yet another aspect, a method of limiting axial movement between a hanger and a fairing within a turbine assembly is provided. The method includes extending a bend portion of the hanger to define a receiving channel therein, extending a hook member from an outer surface of the fairing to mate with the receiving channel, defining a groove in the outer surface such that at least a portion of the hanger bend portion is positioned between the groove and the hook member, inserting a retention member into the groove, and extending the retention member from the groove to press against the hanger bend portion of the hanger to facilitate maintaining the hook member within the receiving channel.

BRIEF DESCRIPTION OF THE DRAWINGS

[0008] Figures 1-20 show exemplary embodiments of the assembly and method described herein.

[0009] Figure 1 is a schematic perspective view of a turbine frame hanger and a collection of fairing sections (e.g., flow path components) according to an embodiment;

[0010] Figure 2 is a schematic perspective view of a turbine frame hanger as it is mounted to a collection of fairing sections according to an embodiment;

[0011] Figure 3 is a schematic cross-sectional view of a turbine frame hanger as it is mounted to a fairing section, according to an embodiment;

[0012] Figure 4 is a schematic cross-sectional view of a turbine frame hanger as it is mounted to a fairing section, according to an embodiment;

[0013] Figure 5 is a schematic cross-sectional view of a turbine frame hanger as it is mounted to a fairing section, according to an embodiment;

[0014] Figure 6 is a schematic cross-sectional view of a turbine frame hanger as it is mounted to a fairing section, according to an embodiment;

[0015] Figure 7 is a schematic cross-sectional view of a turbine frame hanger as it is mounted to a fairing section, illustrating a scalloped opening for receiving a retention member, according to an embodiment;

[0016] Figure 8 is a schematic cross-sectional view of a turbine frame hanger as it is mounted to a fairing section, illustrating a retention member inserted through a scalloped opening, according to an embodiment;

[0017] Figure 9 is a schematic perspective view of a turbine frame hanger as it is mounted to multiple fairing sections, illustrating a retention member inserted through a scalloped opening, according to an embodiment;

[0018] Figure 10 is a schematic perspective view of a turbine frame hanger as it is mounted to multiple fairing sections, illustrating a retention member inserted through a scalloped opening, according to an embodiment;

[0019] Figure 11 is a schematic perspective view of a multi-turn retention member, according to an embodiment;

[0020] Figure 12 is a schematic perspective view of multiple segmented retainers, according to an embodiment;

[0021] Figure 13 is a schematic perspective view of a single-layer, 360 degree retainer ring, according to an embodiment;

[0022] Figure 14 is a schematic perspective view illustrating a single sectioned retainer having a wavy region, according to an embodiment;

[0023] Figure 15 is a schematic perspective view of multiple fairings attached to a hanger utilizing both a single-layer, 360 degree retainer ring topped with a plurality of sectioned retainers having wavy regions, according to an embodiment;

[0024] Figure 16 is a schematic perspective view of multiple fairings attached to a hanger utilizing both a single-layer, 360 degree retainer ring topped with a plurality of sectioned retainers having wavy regions, according to an embodiment;

[0025] Figure 17 is a schematic perspective view of a segmented retainer having a wavy region, according to an embodiment;

[0026] Figure 18 is a schematic perspective view of the wavy region of a segmented retainer, according to an embodiment;

[0027] Figures 19a through 19d illustrate various configurations of retention members for retaining a hanger to a plurality of fairings, according to an embodiment; and

[0028] Figure 20 shows an exemplary tool for installing and removing the retention members shown in Figures 19a through 19d.

DETAILED DESCRIPTION OF THE INVENTION

[0029] Figure 1 is a schematic perspective view of a hanger 100 positioned to abut a front end 102 of a collection of fairings 104 aligned in a circular fashion. The illustrated hanger 100 is shown with a plurality of apertures 106 extending through a front flange 108 for attaching the hanger 100 to a frame 110 of a turbine engine. As shown in Figure 2, the hanger arm 112 of the hanger 100 has a hook channel 114 having a substantially j-shaped cross section, for receiving a fairing circumferential hook 116 of a fairing 104. About a bend portion 118 of the hanger arm 112 is located an annular flat surface 120 that lines up vertically with a fairing circumferential retainer groove 122 in the fairing 104 when the hanger 100 is positioned as shown, such that the hook channel 114 of the hanger 100 is mated with the circumferential hook 116 of the fairing 104. The retainer groove 122 is for receiving an axial retention member 124, which may be a continuous ring with a

single break in it, a continuous ring that substantially comprises a spiral having multiple rotations, a series of segmented retainers, and combinations thereof. The retention member 124 is placed in the retainer groove 122 so that the retention member 124 prevents the fore and aft movement of the fairing 104, and the retention member 124 thereby prevents the hook channel 114 of the hanger 100 from separating from the circumferential hook 116 of the fairing 104. Although a fairing 104 is shown as the flow path component in these exemplary embodiments, it should be recognized by one skilled in the art that any flow path component could take the place of the fairing 104.

[0030] As shown in Figure 3, mechanical entrapment of the hook channel 114 in the circumferential hook 116 of the fairing 104 is accomplished by placing the retention member 124 in the retainer groove 122. A c-clip 126 is then installed adjacent the retention member 124, wherein the c-clip 126 has a horizontal tab 128 extending away from the rear of the c-clip 126. When the c-clip 126 is fully engaged, the horizontal tab 128 is positioned to abut an outer surface 130 of the retention member 124 to facilitate restricting movement of retention member 124 within the retainer groove 122.

[0031] Figure 4 illustrates an embodiment of the retention member 124 as described above, locked into a circumferential retainer groove 122 in a fairing 104. The retention member 124 shown is a single ply ring, having a fore to aft thickness slightly less than the fore to aft distance between the vertical walls of the circumferential retainer groove 122.

[0032] Figures 5 and 6 illustrate another embodiment of a turbine frame hanger lock assembly 10. In this embodiment, the retention member 124 is a double ply, spiral ring, having a 720 degree circumference. A hanger located circumferential retainer groove 132 is provided by extending the hanger 100 about the bend portion 118 of the hanger arm 112, so that the channel of the hanger located circumferential retainer groove 132 substantially mates with the channel 123 of the circumferential retainer groove 122 in the fairings 104.

[0033] Figures 7 through 10 illustrate a scalloped opening 134 in the forward side 136 of the hook channel 114 and the forward side 138 of the fairing. Figure 9 illustrates the scalloped opening 134 and shows that the opening 134 has a predetermined width for receiving a first end 140 of a multi-turn retention member 142. The first end 140 of the multi-turn retention member 142 is inserted into the scalloped opening 134 and the multi-turn retention member 142 is fed around the circumference of the hanger 100, such that the retention member 124 is traveling in an enclosed groove 144. A second end 146 of the ring has a loop that prevents further insertion of the multi-turn ring 142 into the enclosed groove 144.

[0034] As shown in Figure 10, the loop of the second end 146 is configured to be less than the width of the scalloped opening 134 so that the loop can be contained within the scalloped opening 134 when the multi-turn retention member 142 is fully inserted into the enclosed groove 144. Figure 11 illustrates the configuration of the multi-turn retention member 142 having a spiral shape.

[0035] Figures 12 and 13 illustrate a hybrid retaining ring configuration including a first retaining ring 147 (as shown in Figure 13) that extends one full circumference (approximately 360 degrees) around the enclosed groove 144. A bent portion 150 at one end of the first retaining ring 147 prevents the ring from being inserted too far into the enclosed groove 144 and facilitates removal of the first retaining ring 147 therefrom. A second set of segmented retainers 148 (as shown in Figure 12) is then installed on top of the first retaining ring 147, such that each of the set of segmented retainers 148 extends around less than the full circumference of the channel. As illustrated in Figure 12, each of the set of segmented retainers 148 extend a fraction of the circumference of the enclosed groove 144.

[0036] As shown in Figure 14, each of the set of segmented retainers 148 can have a wavy region 152 (e.g., an axial wave) in them to axially preload the contents of the enclosed groove 144. In this case, the first retainer ring 147 is formed without wavy regions such that the first retainer ring 147 is substantially planar in the plane perpendicular to the axis around which the ring 147 extends. According to an embodiment, each segmented retainer 148 may include a ring layer 154 having a

wavy region 152 positioned thereon. A spring clip 156 may be attached to one end of the ring layer 154 for preventing rigid body motion (e.g., circumferential motion). Finally, a spacer 158 is configured to attach the spring clip 156 to a top surface of the ring layer 154. According to another embodiment, each segmented retainer 148 may include a layer 154 having a wavy region 152, and an integrated spring clip 160.

[0037] In one embodiment, the sets of segmented retainers 148 is inserted into the channel as shown in Figures 15 and 16, through the scalloped openings 134, such that each segmented retainer 148 with a wavy region 152 axially preloads the channel, preventing axial (e.g., fore and aft) movement of the first retaining ring 147 and each of the segmented retainers 148. The interface between the hanger 100 and the fairings 104 forms the scalloped openings 134 such that there is one scalloped opening 134 formed when two fairings 104 are placed side-by-side and a hanger 100 is positioned adjacent the fairings 104, as shown in Figure 15. The wavy region 152 of each of the set of segmented retainers 148 is illustrated in Figures 17 and 18.

[0038] Figures 19a through 19d illustrate various alternative configurations for retention members. In Figure 19d, the continuous multi-turn retention member 124 is illustrated.

[0039] Figure 19a illustrates a hybrid retention member configuration including a first retention member 162 that extends one full circumference around the channel, and a second set of segmented retainers 164 that are inserted through scalloped openings 134 adjacent the first retention member 162, such that each of the retention members 164 extend one quarter of the circumference of the hanger 100.

[0040] Figure 19b illustrates a ring configuration including sixteen ring portions 166 that each extend one-sixteenth of the circumference of the hanger 100. Each ring portion 166 is inserted through a scalloped opening 134 to extend within the enclosed groove 144 until the loop 168 prevents further insertion.

[0041] Figure 19c illustrates a retention configuration including four retention member portions 170 that each extend one-fourth of the circumference of the hanger 100. Each retention member portion 170 is inserted through a scalloped

opening 134 to extend within the enclosed groove 144 until the loop 172 prevents further insertion.

[0042] Figure 20 shows an X-shaped tool 174 for installing and removing a retention member 124 or segmented retainer. The X-shaped tool 174 has four advancing pins 176 for insertion into apertures 178 in the retention member 124 or segmented retainer. During installation of the retention member 124 or segmented retainer, a portion of the retention member 124 or segmented retainer is bent in the direction opposite the scalloped opening, until the retention member 124 or segmented retainer is fully installed in the scalloped opening. Because of this bend in the retention member 124 or segmented retainer, an advancing pin 176 of the X-shaped tool 174 can be inserted into a given aperture so that the X-shaped tool 174 is rotated in a counter clockwise manner, pushing the retention member 124 or segmented retainer into the scalloped opening. When a downstream aperture is nearly inserted into the scalloped opening, another of the advancing pins 176 engages an upstream aperture to continue installation. Once the entire retention member 124 or segmented retainer is inserted into the scalloped opening, the X-shaped tool 174 is removed. By reversing the direction of rotation of the X-shaped tool 174, a retention member 124 or segmented retainer can be removed from the scalloped opening.

[0043] Exemplary embodiments of a turbine hanger lock assembly and methods of assembling the turbine hanger lock assembly are described above in detail. The assembly and method are not limited to the specific embodiments described herein, but rather, components of the assembly and/or steps of the method may be utilized independently and separately from other components and/or steps described herein. Further, the described assembly components and/or the method steps can also be defined in, or used in combination with, other assemblies and/or methods, and are not limited to practice with only the assembly and/or method as described herein.

[0044] This written description uses examples to disclose the invention, including the best mode, and also to enable any person skilled in the art to make and use the invention. The patentable scope of the invention is defined by the claims, and

may include other examples that occur to those skilled in the art. Such other examples are intended to be within the scope of the claims if they have structural elements that do not differ from the literal language of the claims, or if they include equivalent structural elements with insubstantial differences from the literal languages of the claims.

WHAT IS CLAIMED IS:

1. A system for use in limiting axial movement between a hanger and a fairing assembly within a turbine assembly, wherein the hanger includes an inner radial hanger bend portion that defines a hook channel therein and the fairing assembly includes an outer surface, a hook member extending from the outer surface to mate with the hook channel, and a circumferential groove defined in the outer surface such that at least a portion of the hanger bend portion is positioned between the circumferential groove and the hook member, said system comprising:

a retention member sized for insertion into the circumferential groove, wherein the retention member is configured to extend from the circumferential groove and press against the hanger bend portion to facilitate maintaining the hook member within the hook channel.

2. The system in accordance with Claim 1, wherein said retention member comprises an annular ring that extends at least a full circumference about the circumferential groove.

3. The system in accordance with Claim 2, wherein said annular ring comprises a multi-turn ring having at least two rotations within the circumferential groove.

4. The system in accordance with Claim 1, wherein said retention member has a thickness that facilitates reducing a clearance fit of said retention member within the circumferential groove.

5. The system in accordance with Claim 1, wherein said retention member comprises a segmented retainer that extends less than a full circumference of the circumferential groove.

6. The system in accordance with Claim 5, wherein said segmented retainer comprises a wavy region that is configured to preload said retention member within the circumferential groove.

7. The system in accordance with Claim 1, wherein said retention member comprises:

an annular ring sized for insertion into the circumferential groove with a clearance fit; and

a segmented retainer sized for insertion in the circumferential groove, wherein said segmented retainer has a thickness that facilitates reducing the clearance fit between said annular ring and the circumferential groove.

8. A turbine assembly comprising:

a hanger including an inner radial hanger bend portion that defines a hook channel therein;

a fairing including an outer surface, a hook member extending from said outer surface to mate with said hook channel, and a groove defined in said outer surface such that a portion of said hanger bend portion is positioned between said groove and said hook member; and

a retention member sized for insertion into said groove, wherein said retention member is configured to extend from said groove and press against said hanger bend portion to facilitate maintaining said hook member within said hook channel.

9. The assembly in accordance with Claim 8, wherein said hanger bend portion comprises a surface that aligns with said groove such that said retention member extends from said groove to press against said surface.

10. The assembly in accordance with Claim 9 further comprising a holding tab coupled to said retention member to maintain insertion of said retention member within said groove.

11. The assembly in accordance with Claim 10, wherein said retention member is positioned between said holding tab and said groove when said holding tab is coupled thereto.

12. The assembly in accordance with Claim 8, wherein a second portion of said hanger bend portion extends past said groove, wherein said second portion

comprises a second groove defined therein that substantially aligns with said fairing groove to form an enclosed groove.

13. The assembly in accordance with Claim 12, wherein said hanger bend portion comprises a first slot and said fairing comprises a second slot that substantially aligns with said first slot to form a scalloped opening that is configured to receive said retention member therethrough for insertion into said receiving slot.

14. The assembly in accordance with Claim 13, wherein said retention member comprises a first end sized for insertion into said scalloped opening, wherein said retention member is fed through said scalloped opening to insert said retention member into said receiving slot.

15. The assembly in accordance with Claim 14, wherein said retention member comprises a locking mechanism defined at an opposing second end of said retention member, wherein said locking mechanism facilitates limiting rotation of said retention member within said receiving slot.

16. A method of limiting axial movement between a hanger and a fairing within a turbine assembly, said method comprising:

extending a bend portion of the hanger to define a hook channel therein;

extending a hook member from an outer surface of the fairing to mate with the hook channel;

defining a groove in the outer surface such that at least a portion of the hanger bend portion is positioned between the groove and the hook member;

inserting a retention member into the groove; and

extending the retention member from the groove to press against the hanger bend portion of the hanger to facilitate maintaining the hook member within the hook channel.

17. The method in accordance with Claim 16, wherein extending the retention member comprises extending the retention member to press against a surface of the

hanger bend portion such that the hanger bend portion is positioned between the retention member and the hook member.

18. The method in accordance with Claim 16, wherein extending the retention member comprises inserting the retention member into a second groove defined in the hanger bend portion that substantially aligns with the fairing groove to form an enclosed groove.

19. The method in accordance with Claim 16, wherein inserting a retention member into the groove comprises:

inserting an annular ring into the groove with a clearance fit; and

inserting a segmented retainer into the groove, wherein the segmented retainer has a thickness that facilitates reducing the clearance fit between the annular ring and the groove.

20. The method in accordance with Claim 19, wherein inserting a segmented retainer comprises preloading the retention member within the groove with a wavy region of the segmented retainer.

1/13

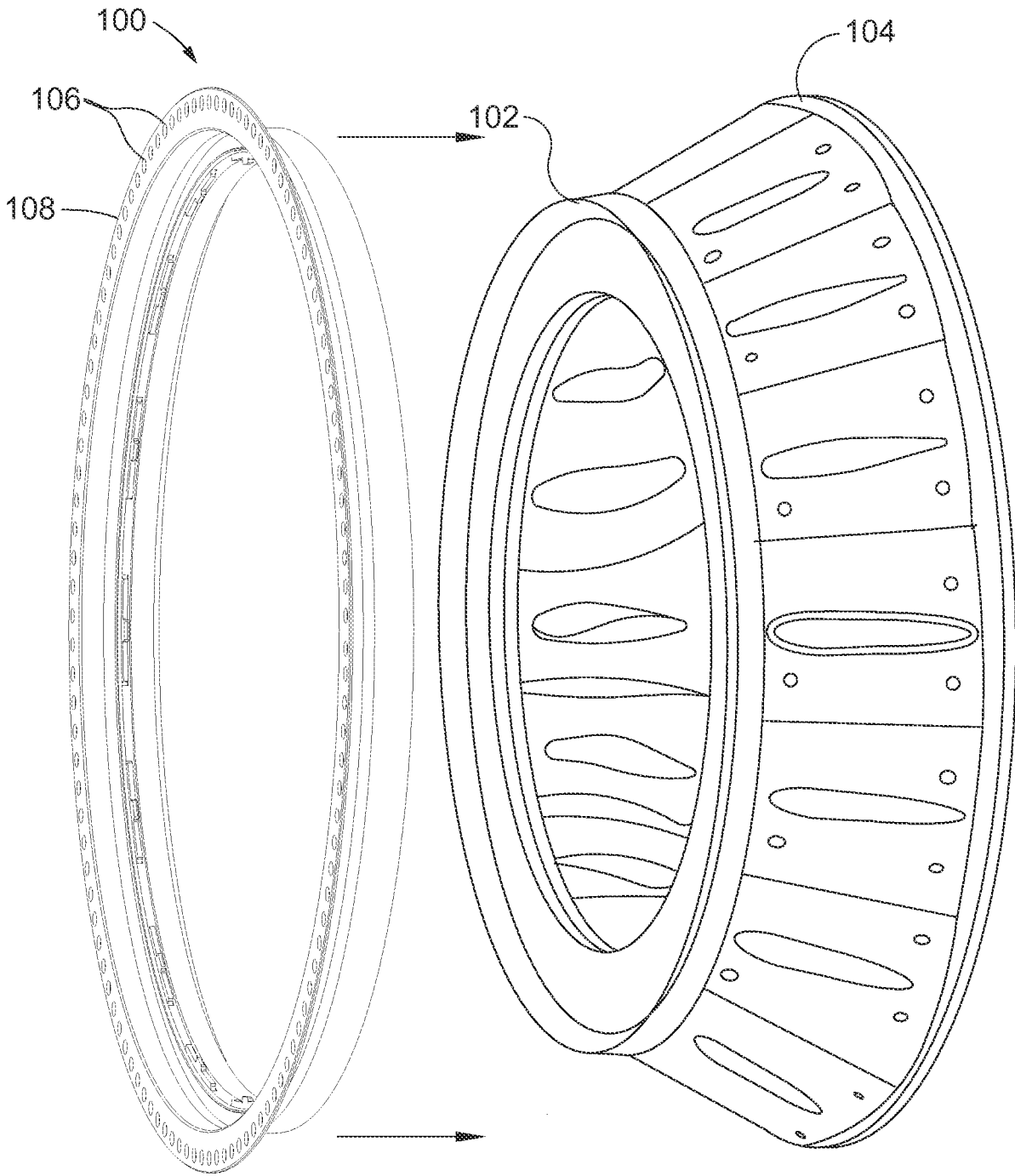

FIG. 1

2/13

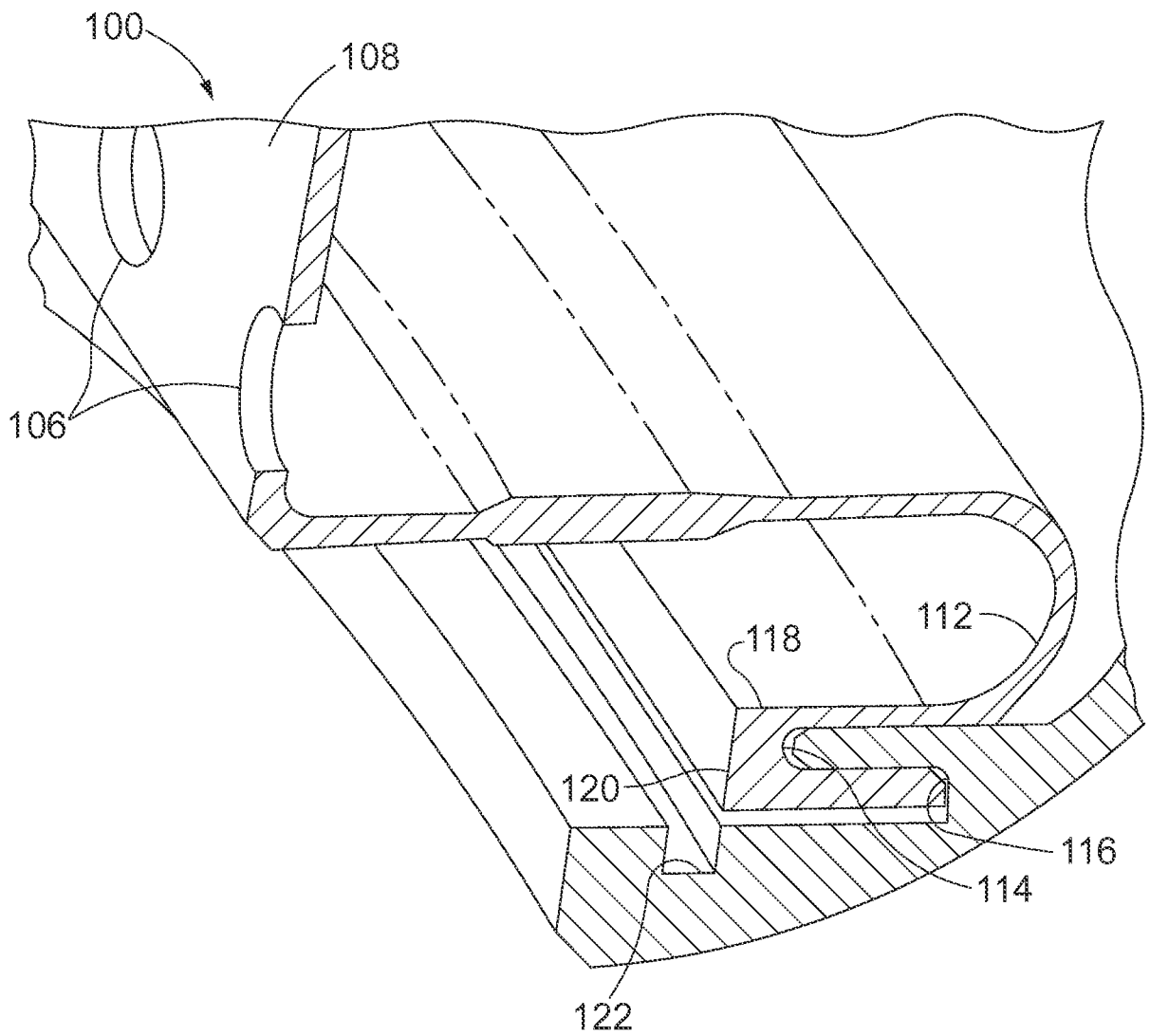
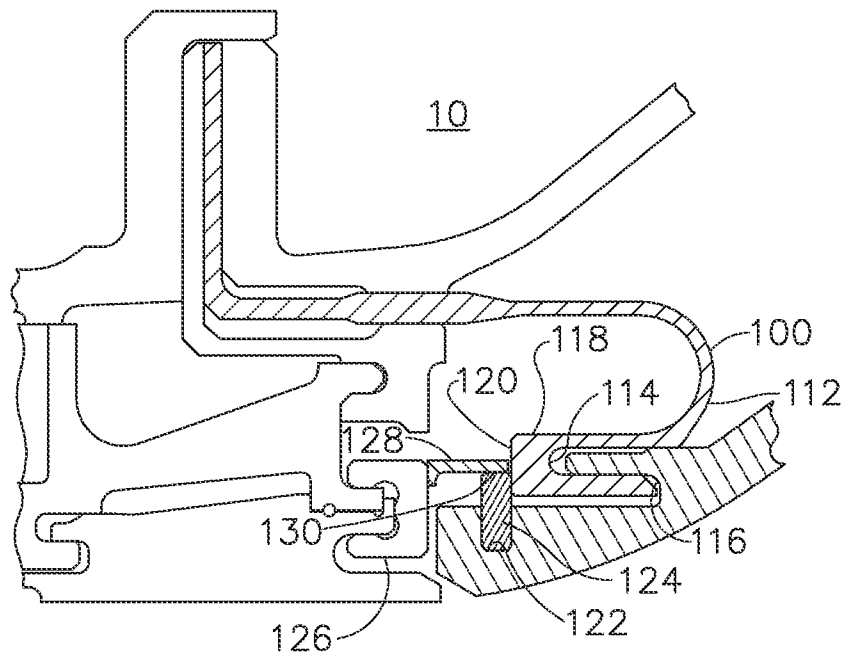
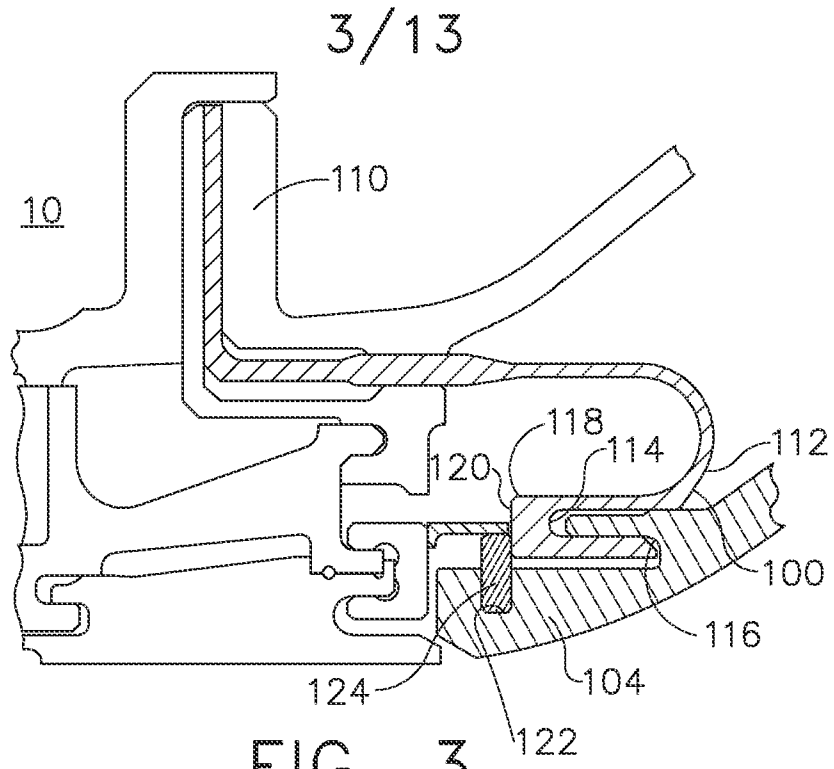

FIG. 2



4/13

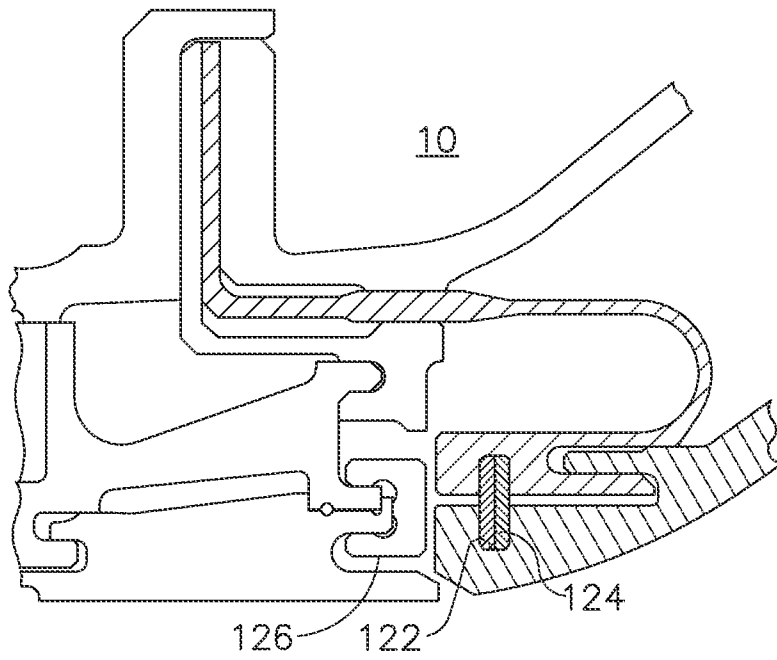

FIG. 5

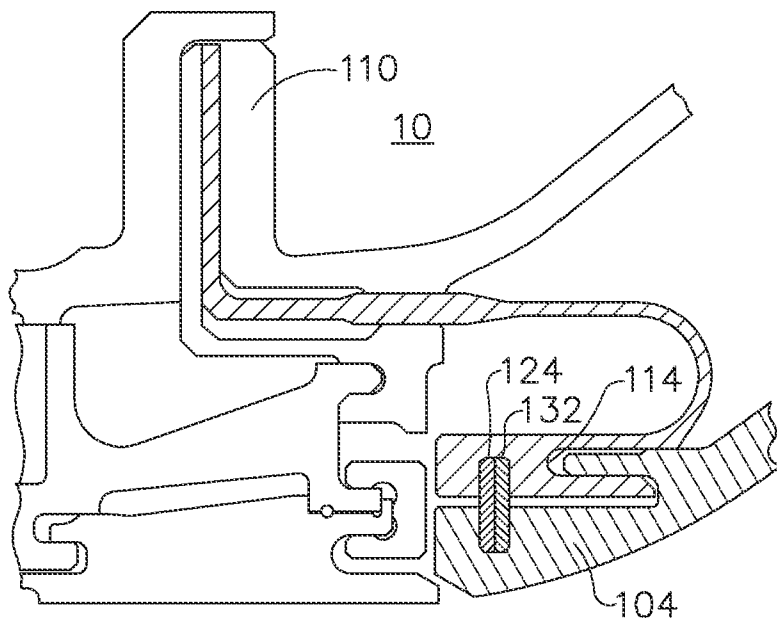

FIG. 6

5/13

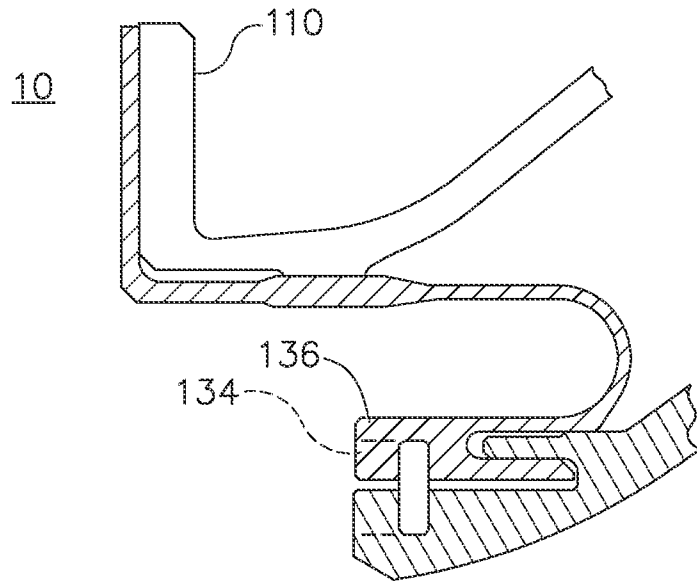

FIG. 7

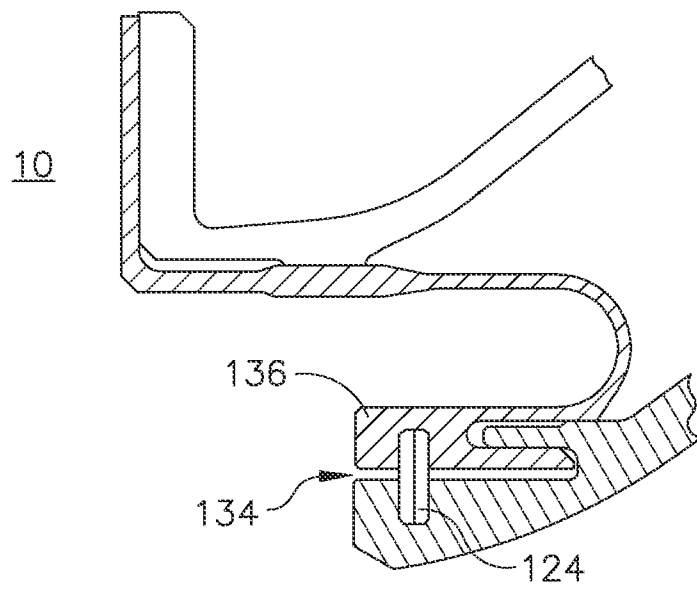

FIG. 8

6/13

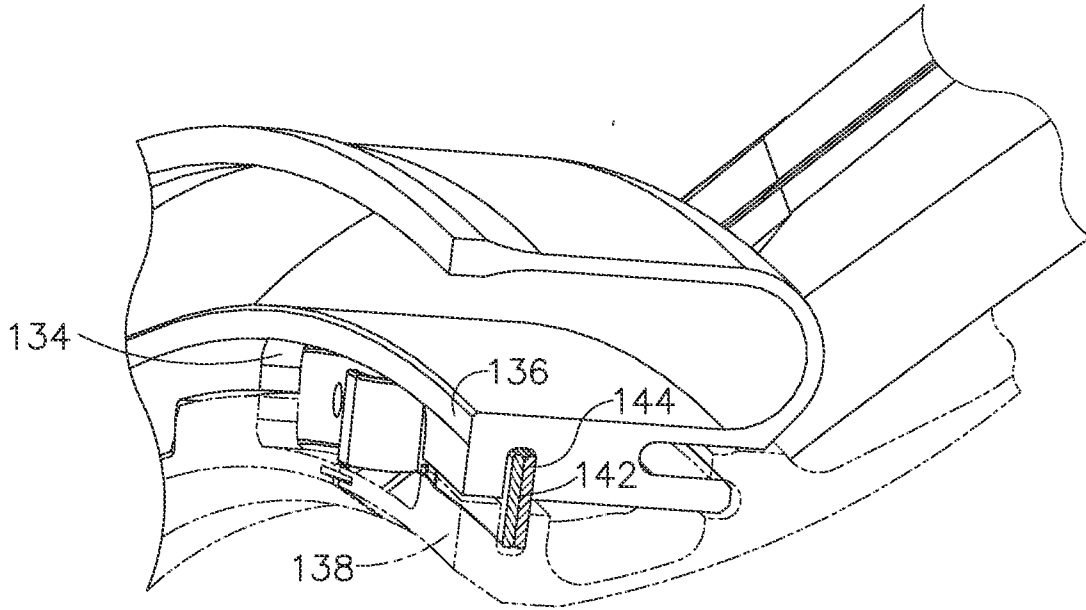

FIG. 9

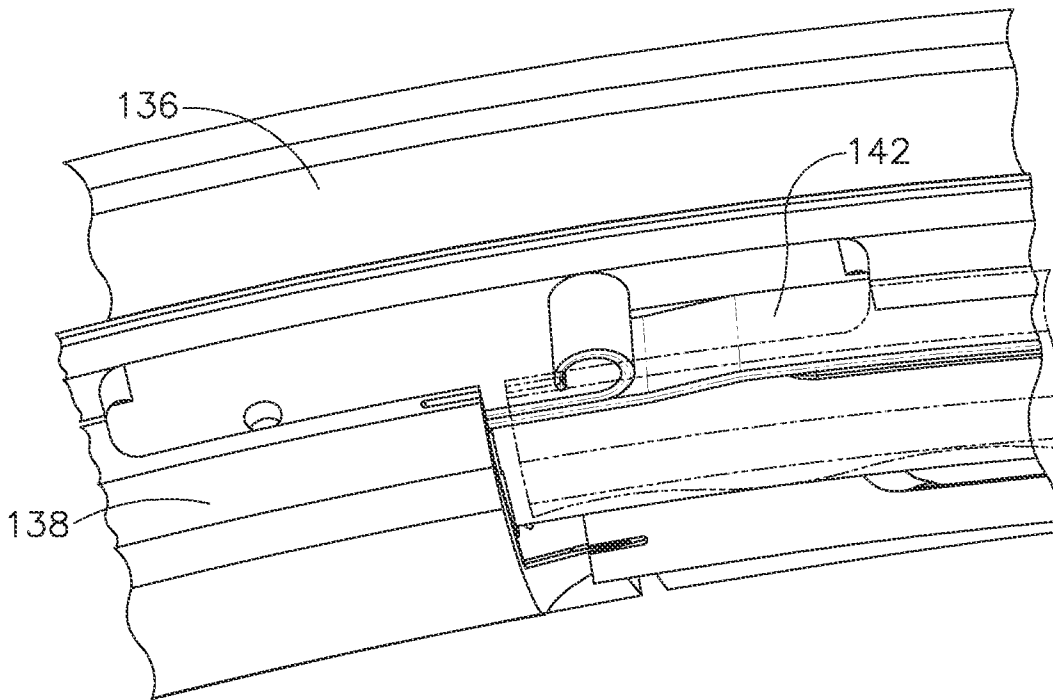

FIG. 10

7/13

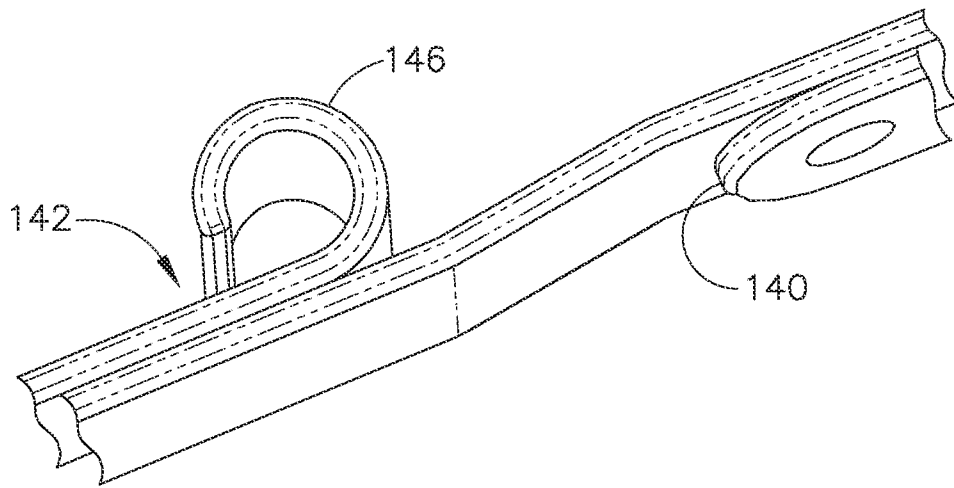

FIG. 11

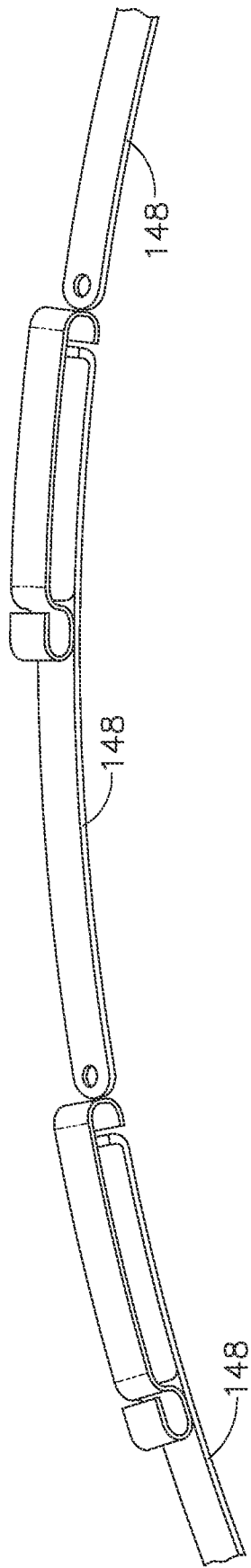

FIG. 12

8/13

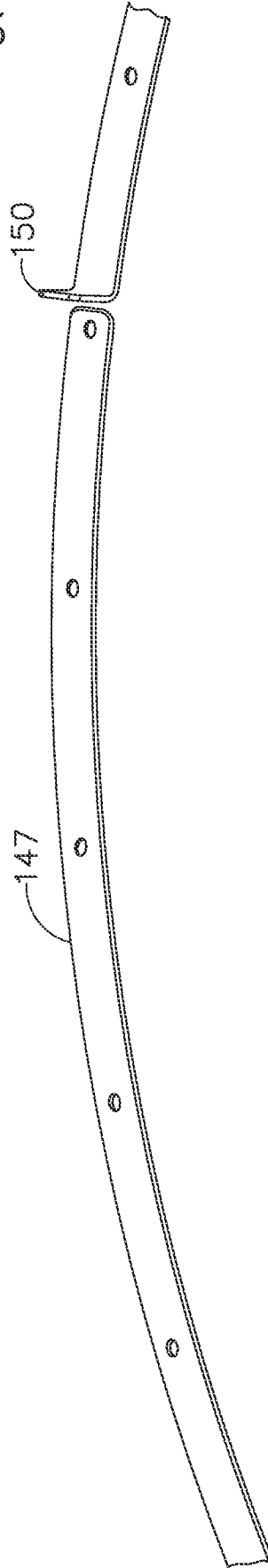

FIG. 13

9/13

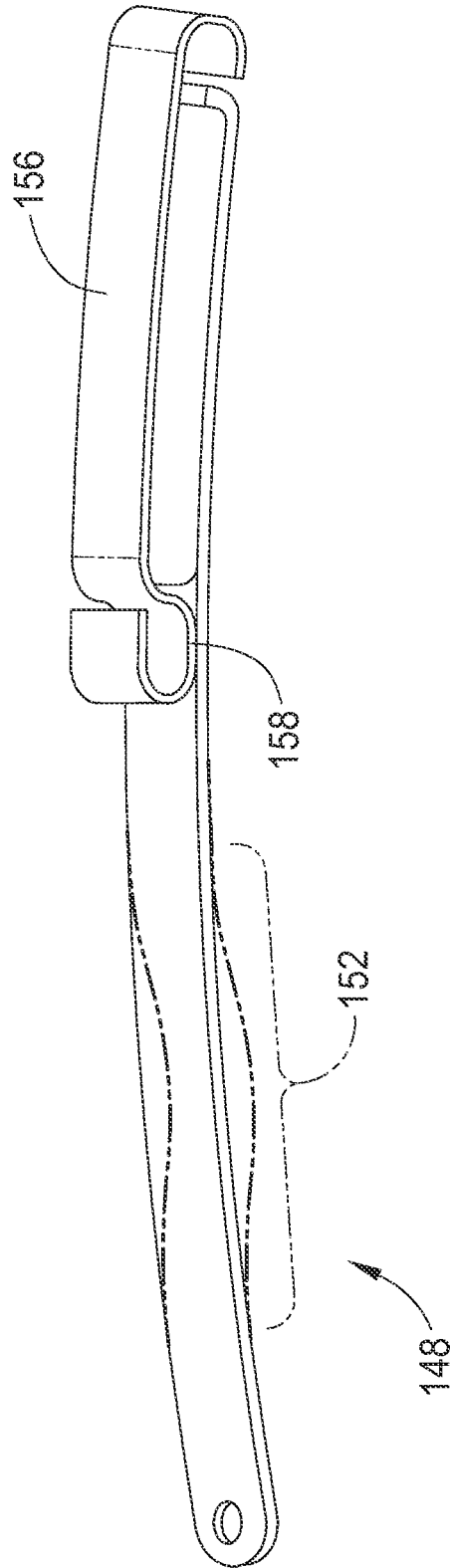

FIG. 14

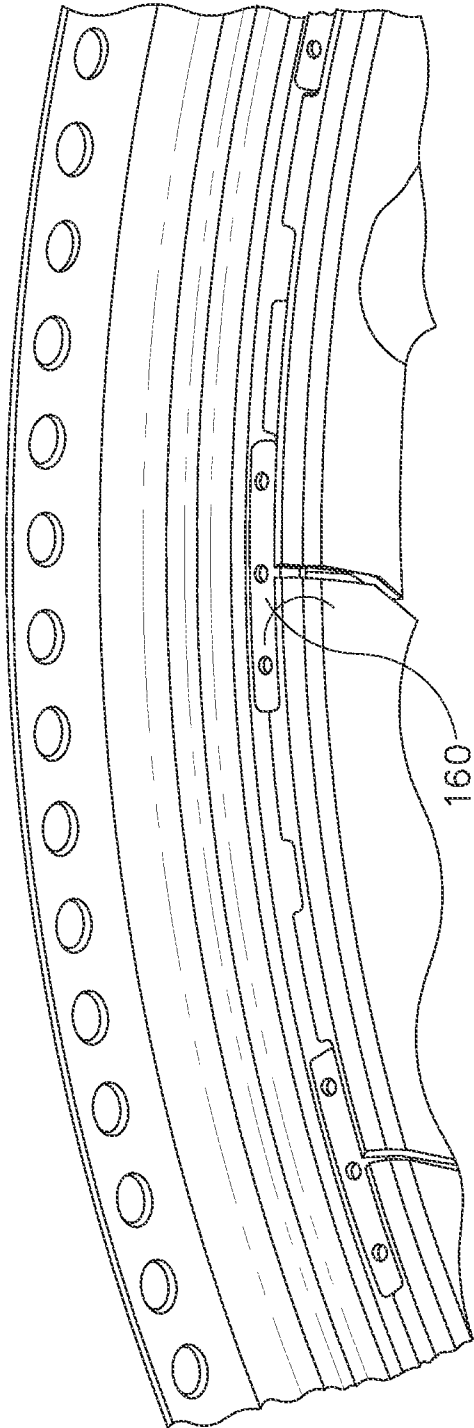

FIG. 15

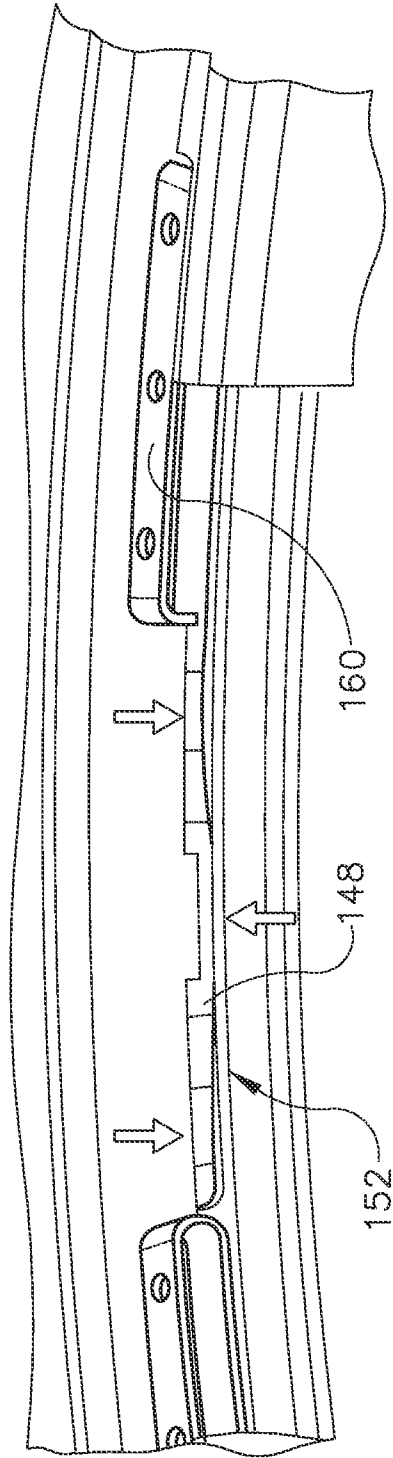

FIG. 16

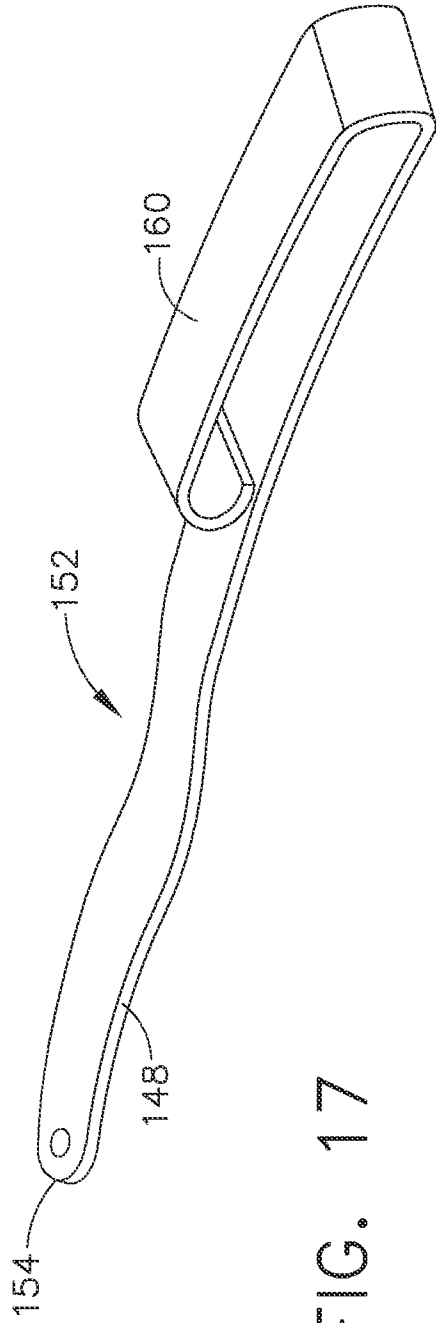

FIG. 17

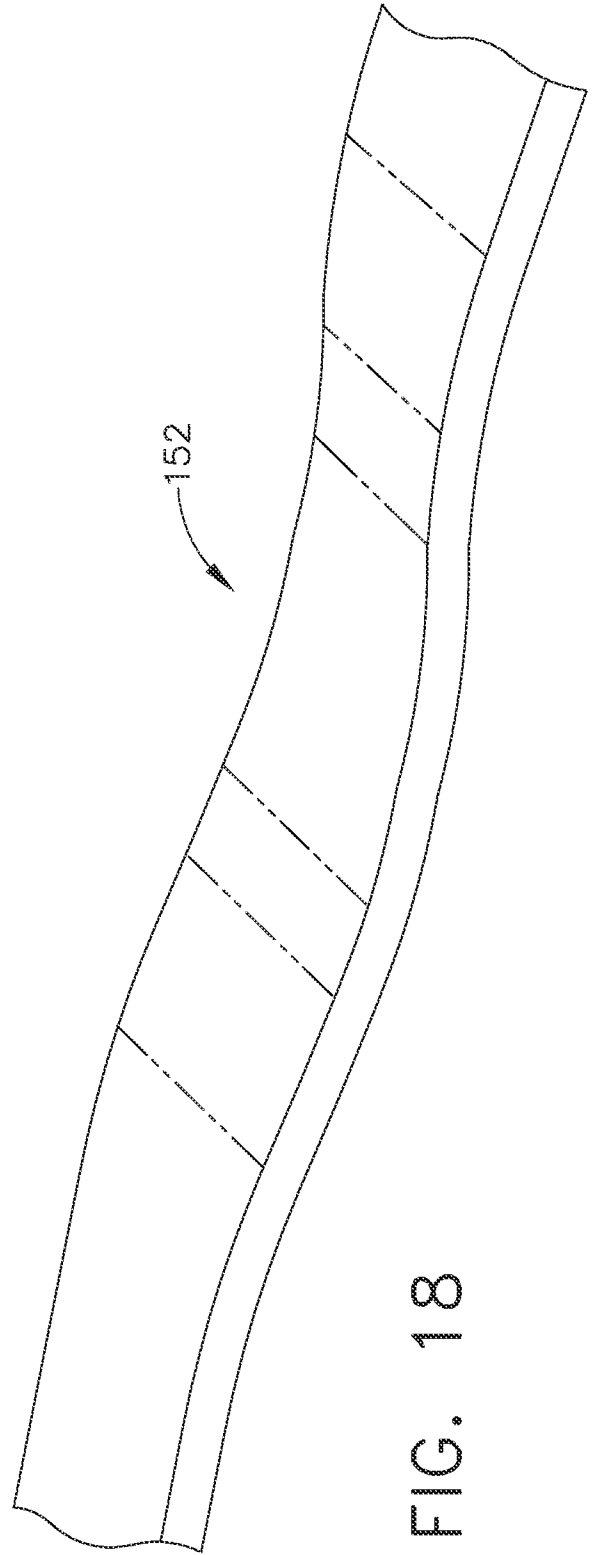

FIG. 18

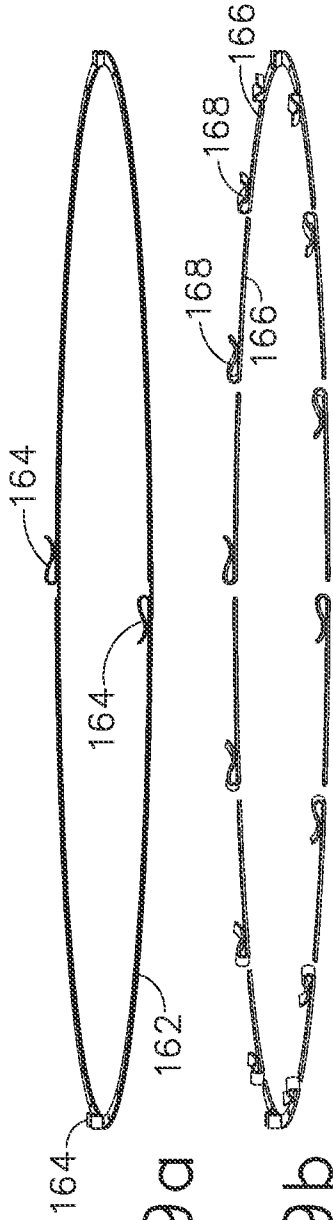

FIG. 19a

FIG. 19b

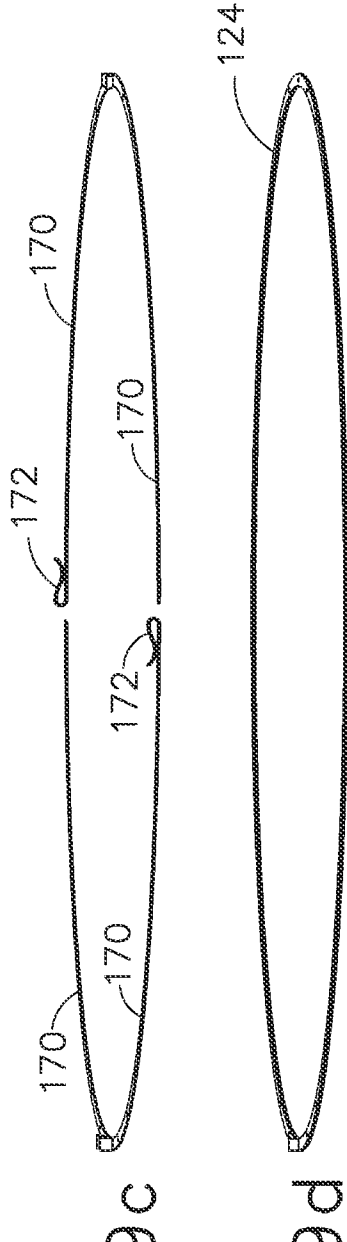
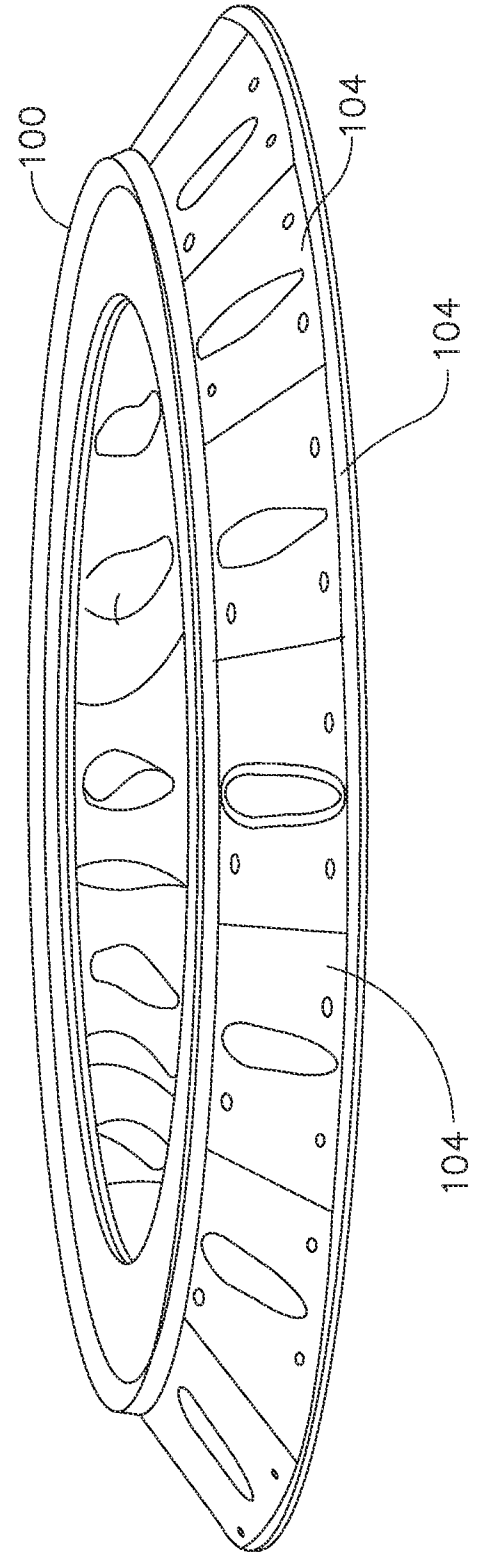

FIG. 19c

FIG. 19d



104

100

INTERNATIONAL SEARCH REPORT

International application No
PCT/US2013/038464

A. CLASSIFICATION OF SUBJECT MATTER
INV. F01D25/24 F01D25/26
ADD.
According to International Patent Classification (IPC) or to both national classification and IPC

B. FIELDS SEARCHED
Minimum documentation searched (classification system followed by classification symbols)
F01D
Documentation searched other than minimum documentation to the extent that such documents are included in the fields searched

Electronic data base consulted during the international search (name of data base and, where practicable, search terms used)
EPO-Internal

C. DOCUMENTS CONSIDERED TO BE RELEVANT		
Category*	Citation of document, with indication, where appropriate, of the relevant passages	Relevant to claim No.
X A	US 2010/247298 A1 (NAKAMURA ORIO [JP] ET AL) 30 September 2010 (2010-09-30) paragraph [0027] - paragraph [0049]; claim 1	1,2,8,9, 16,17 3-7, 10-15, 18-20
X	----- EP 1 707 749 A2 (UNITED TECHNOLOGIES CORP [US]) 4 October 2006 (2006-10-04) paragraph [0009] - paragraph [0022]; figures 1-14	1,2,8,9, 16,17
X,P A,P	----- FR 2 980 235 A1 (SNECMA [FR]) 22 March 2013 (2013-03-22) page 5 - page 9; claim 1; figures 1-6	1,2,8,9, 16,17 3-7, 10-15, 18-20

Further documents are listed in the continuation of Box C.

See patent family annex.

* Special categories of cited documents :

"A" document defining the general state of the art which is not considered to be of particular relevance	"T" later document published after the international filing date or priority date and not in conflict with the application but cited to understand the principle or theory underlying the invention
"E" earlier application or patent but published on or after the international filing date	"X" document of particular relevance; the claimed invention cannot be considered novel or cannot be considered to involve an inventive step when the document is taken alone
"L" document which may throw doubts on priority claim(s) or which is cited to establish the publication date of another citation or other special reason (as specified)	"Y" document of particular relevance; the claimed invention cannot be considered to involve an inventive step when the document is combined with one or more other such documents, such combination being obvious to a person skilled in the art
"O" document referring to an oral disclosure, use, exhibition or other means	"&" document member of the same patent family
"P" document published prior to the international filing date but later than the priority date claimed	

Date of the actual completion of the international search 8 August 2013	Date of mailing of the international search report 16/08/2013
---	---

Name and mailing address of the ISA/ European Patent Office, P.B. 5818 Patentlaan 2 NL - 2280 HV Rijswijk Tel. (+31-70) 340-2040, Fax: (+31-70) 340-3016	Authorized officer Balice, Marco
--	--

INTERNATIONAL SEARCH REPORT

Information on patent family members

International application No

PCT/US2013/038464

Patent document cited in search report	Publication date	Patent family member(s)	Publication date	
US 2010247298	A1	30-09-2010	JP 2010229925 A	14-10-2010
			US 2010247298 A1	30-09-2010

EP 1707749	A2	04-10-2006	NONE	

FR 2980235	A1	22-03-2013	NONE	
