

J. W. MILLAM.  
 APPARATUS FOR FORMING CONCRETE FENCE POSTS.  
 APPLICATION FILED DEC. 7, 1908.

925,009.

Patented June 15, 1909.

2 SHEETS—SHEET 1.

Fig. 1.

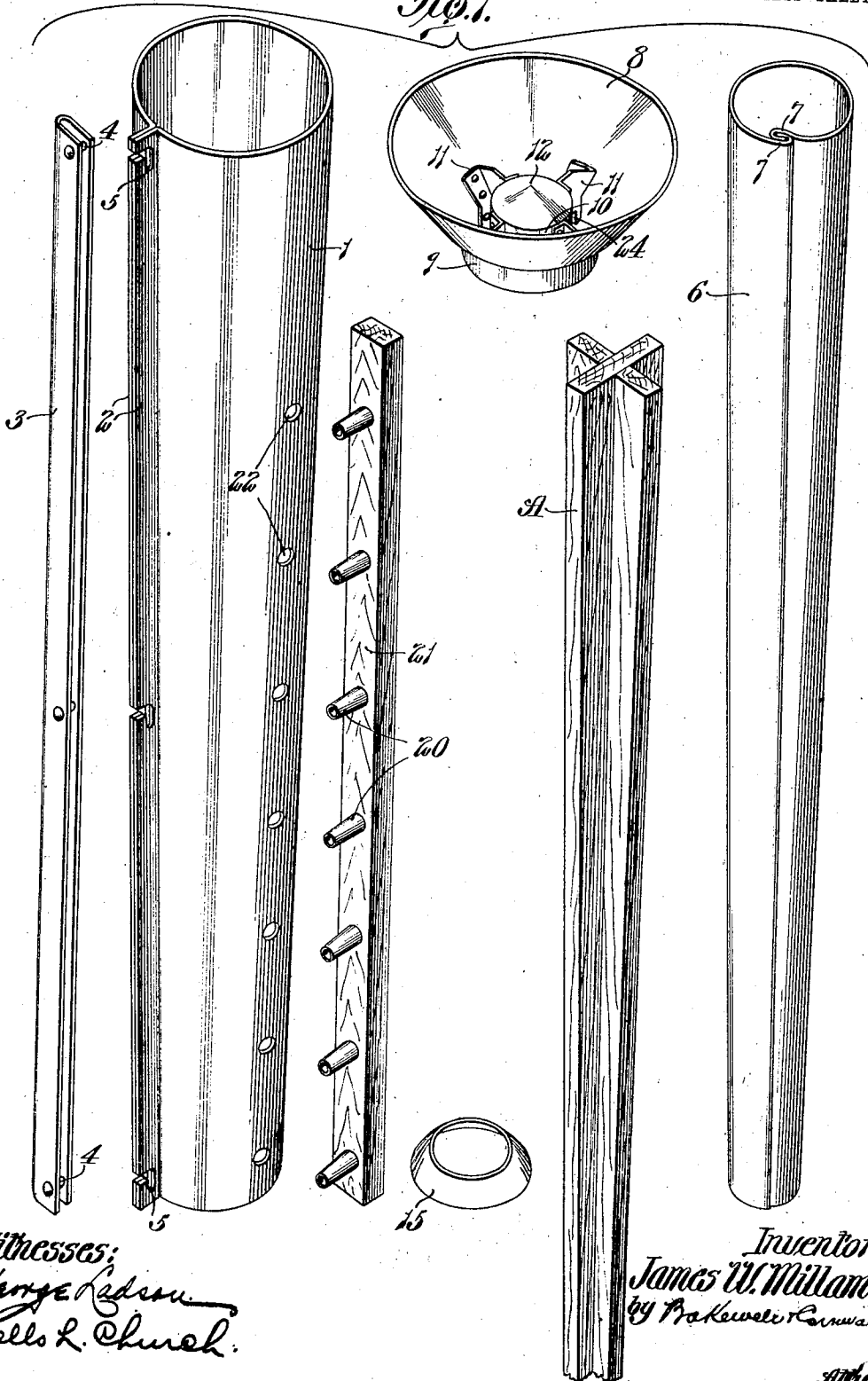

Witnesses:  
 George Radson  
 Wells L. Church.

Inventor,  
 James W. Millam.  
 by Prokewski & Canwell

Atty.

J. W. MILLAM.  
 APPARATUS FOR FORMING CONCRETE FENCE POSTS.  
 APPLICATION FILED DEC. 7, 1908.

925,009.

Patented June 15, 1909.

2 SHEETS—SHEET 2.

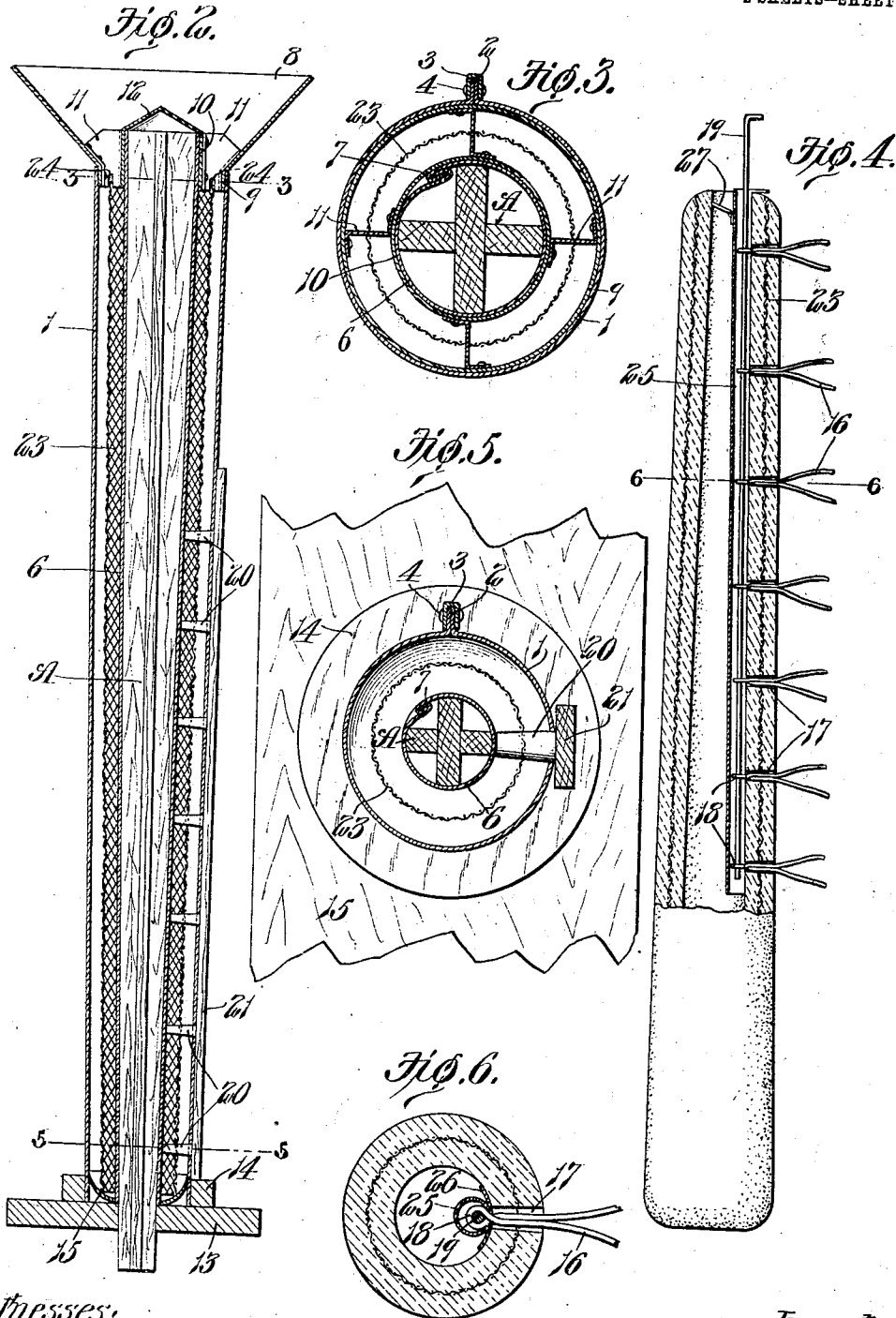

Witnesses:  
 George Jackson  
 Miles L. Church

Inventor,  
 James W. Millam.  
 by McKee & Cornwall Attys.

# UNITED STATES PATENT OFFICE.

JAMES W. MILLAM, OF ST. LOUIS, MISSOURI, ASSIGNOR OF ONE-HALF TO GEORGE M. JENNINGS, OF ST. LOUIS, MISSOURI.

## APPARATUS FOR FORMING CONCRETE FENCE-POSTS.

No. 925,009.

Specification of Letters Patent.

Patented June 15, 1909.

Application filed December 7, 1908. Serial No. 466,32

To all whom it may concern:

Be it known that I, JAMES W. MILLAM, a citizen of the United States, residing at St. Louis, Missouri, have invented a certain new and useful Improvement in Apparatus for Forming Concrete Fence-Posts, of which the following is a full, clear, and exact description, such as will enable others skilled in the art to which it appertains to make and use the same, reference being had to the accompanying drawings, forming part of this specification, in which—

Figure 1 is a perspective view showing the various parts of my improved apparatus; Fig. 2 is a vertical sectional view showing the parts of my improved apparatus in operative position; Fig. 3 is an enlarged cross sectional view taken approximately on the line 3—3 of Fig. 2; Fig. 4 is an elevational view, partly in vertical section, of the fence-post which my improved apparatus forms, the yielding clamping member which retains the fence wire connecting devices in place being shown in operative position; Fig. 5 is an enlarged cross sectional view taken approximately on the line 5—5 of Fig. 2; and Fig. 6 is a cross sectional view taken approximately on the line 6—6 of Fig. 4.

This invention relates to molds for forming concrete articles, and particularly to molds for forming hollow concrete fence-posts.

The main object of my invention is to provide a simple apparatus for forming a round and hollow concrete fence-post.

Referring to the drawings which illustrate the preferred form of my invention, 1 designates an outer cylindrical-shaped shell that is slightly tapered, and which consists of a piece of sheet metal having its edge portion bent laterally to form two parallel flanges 2 that are adapted to be held in engagement with each other by a channel-shaped locking member 3 provided with cross pins 4 that enter bayonet slots 5 in the flanges 2. A collapsible core 6, which is also tubular-shaped and slightly tapered, is arranged inside of the outer shell 1, and this collapsible core consists of a piece of sheet metal provided on its edges with U-shaped flanges 7 that are adapted to interlock with each other when the core is expanded by means of a tapered member A that is introduced into same, said member A preferably consisting of boards or pieces of wood that are con-

nected together in such a manner that they form a member which is substantially cruciform shape in cross section so that it will bear at four points on the inner surface of the collapsible core 6.

A funnel 8 is provided for receiving the plastic material from which the post is formed, thus causing said material to flow down into the space between the outer shell 1 and the inner core 6, said funnel being arranged at the upper enlarged ends of the outer shell 1 and core 6 after they have been assembled, as shown in Fig. 2. The funnel 8 is provided with a depending flange 9 that fits snugly inside of the outer shell 1 so as to prevent it from collapsing, and said funnel is also provided with a ring 10 that is adapted to embrace the inner core 6 and prevent it from expanding, said ring 10 being arranged inside of the flange 9 and retained in operative position by a number of Z-shaped brackets 11, as shown clearly in Fig. 1. I prefer to provide the ring 10 with a conical-shaped cap 12 that prevents the plastic concrete from flowing into the core 6 and also operates to distribute the concrete uniformly around the space between the outer shell and the inner core of the mold. The lower end of the outer shell 1 rests upon a base plate 13 provided with a ring-shaped portion 14 that embraces the lower end of the outer shell, and said base plate is provided with an opening through which the expanding member A projects when the parts of the mold are in operative position. The post which my improved apparatus forms, is hollow and slightly tapered, as shown in Fig. 4, and the upper and lower ends of said post are rounded off slightly so as to eliminate sharp corners that would be apt to break off or chip. These rounded ends are produced by means of cup-shaped rings 15, one of which is shown in operative position in Fig. 2, said ring being arranged upon the base plate 13 between the outer shell and the inner core of the mold so as to form the upper end of the post. The ring that forms the base end of the post is not shown but is substantially the same as the ring 15 and is adapted to be arranged in position between the outer shell and inner core after the funnel 8 has been removed and then rotated slightly so as to smooth down the concrete and cause it to conform to the shape of the ring.

110

The complete post is provided with a number of devices 16 to which the fence-wires are connected, each of said devices consisting of a loop or strand of wire arranged in an opening 17 in the post and provided at its inner end with an eye 18 through which a rod 19 passes, said rod passing through the eyes of all of the devices 16 so as to retain them in position. The holes 17 in which the fastening devices 16 are arranged, are formed during the operation of molding the post by means of a number of pins 20 carried by a bar 21 which is arranged outside of the outer shell 1, as shown in Fig. 2, said outer shell being provided with holes 22 through which the pins 20 project into the space between the inner core and the outer shell and having their inner ends abutting against the outer surface of the collapsible core 6.

The post is preferably reinforced and strengthened by means of a piece of woven wire 23 that is arranged between the inner core and outer shell before the concrete is poured. Any suitable means can be provided for holding this reinforcing wire in position but I prefer to provide the brackets 11 on the funnel with notches 24 into which the upper edge of the woven wire 23 projects, as shown clearly in Fig. 2.

The devices 16, to which the fence wires are connected, are arranged in operative position after the post has been molded, and a clamping member 25 is provided for retaining all of the devices 16 in such a position that the rod 19 can be passed through the eyes 18 thereof. This clamping member 25 preferably consists of a piece of resilient metal bent into approximately tubular form, as shown in Fig. 6, and provided on its edges with laterally projecting flanges 26 that bear upon the inside of the post. After the devices 16 have been inserted in the holes 17 in the post and turned so that the eyes 18 of said devices are arranged horizontally, the clamping member 25 is sprung over the eyes 18 so as to retain them in position, the rod 19 being thereafter forced downwardly through the eyes of all the devices 16. As shown in Fig. 4, the clamping member 25 is provided adjacent its upper end with a hinged brace 27 that is adapted to be moved downwardly into engagement with the inner wall of the post so as to retain the clamping member in position.

To form a hollow concrete fence-post with an apparatus of the construction above described, I first arrange the outer shell 1 in an upright position on the base plate 13, the U-shaped clamping member 3 being forced over the flanges 2 of said shell and then downwardly so that the pins 4 lie at the lower ends of the bayonet-shaped slots 5 in said flanges. The inner collapsible core 6 is then arranged inside of the outer shell, and the expanding

member A is forced downwardly into said core until the flanges 7 interlock. After the reinforcing wire 23 has been arranged between the outer shell and inner core the funnel 8 is arranged in position and the concrete is thereafter poured into the funnel so that it will flow into the space between the outer shell and inner core, the bar 21, provided with the pins 20, having been previously arranged in position so that said pins will project inwardly through the outer shell, as shown in Fig. 2. After the funnel has been removed one of the cup-shaped rings 13 is used for molding the concrete so as to form the rounded base end of the post, and after the concrete has set sufficiently the outer shell and inner collapsible core are removed. The removal of the inner shell is effected by driving the tapered expanding member A upwardly so that the inner core will contract and the removal of the outer shell is effected by disengaging the clamping member from the flanges 2 so as to permit said outer shell to expand. The devices 16, to which the fence wires are connected, are thereafter arranged in the holes 17 of the post and retained in position by the yielding clamping member 25 so as to enable the rod 19 to be inserted through the eyes of said devices, the member 25 being drawn out of the post after the rod 19 has been inserted.

Having thus described my invention, what I claim as new and desire to secure by Letters Patent is:

1. An apparatus for the purpose described, comprising a tapered outer shell which consists of a piece of sheet metal bent into approximately tubular shape and provided on its longitudinal edges with laterally projecting flanges that press against each other, a channel-shaped clamping member extending longitudinally of said flanges and embracing same so as to prevent the outer shell from expanding, cross-arms on said channel-shaped member that project into bayonet-shaped slots in said flanges so as to retain said clamping member in position, an inner collapsible core arranged inside of the outer shell, means for holding said core spaced away from said shell, and means for expanding said core; substantially as described.

2. An apparatus for the purpose described, comprising an outer shell consisting of a piece of sheet metal bent into approximately tubular shape and provided on its edges with laterally projecting flanges, means cooperating with said flanges for preventing the outer shell from expanding, an inner collapsible core consisting of a piece of sheet metal bent into approximately tubular shape and provided on its edges with hook-shaped flanges that interlock with each other, and a removable expanding member extending through the center of said inner core so as to expand

same and thus hold said hook-shaped flanges in engagement with each other; substantially as described.

3. An apparatus for the purpose described, comprising an outer shell consisting of a piece of sheet metal bent into approximately tubular shape and provided on its edges with laterally projecting flanges that contact with each other, means cooperating with said flanges for preventing the outer shell from expanding; an inner collapsible core consisting of a piece of sheet metal bent into approximately tubular shape and provided on its edges with hook-shaped flanges that interlock with each other, a removable expanding member extending through the center of said inner core so as to expand same and thus hold said hook-shaped flanges in engagement with each other, and a funnel provided with a flange that fits inside of the outer shell, a ring-shaped portion that embraces the upper end of the inner core, and a device that covers said inner core; substantially as described.

4. An apparatus for the purpose described, comprising a tubular-shaped outer shell, a tubular-shaped collapsible shell arranged inside of same, a wedge-shaped member arranged inside of and bearing against the inner face of said collapsible shell throughout its entire length, a funnel arranged at the upper ends of said shells, a cone-shaped member adapted to embrace and shield the upper ends of said collapsible and wedge-shaped members, and connected to and spaced away from said funnel by means of slitted brackets which are adapted to position a reinforcing medium in said apparatus; substantially as described.

5. An apparatus for the purpose described, comprising a base plate, an outer shell consisting of a piece of sheet metal bent into approximately tubular shape and provided on its longitudinal edges with laterally projecting flanges having bayonet slots formed therein, a channel-shaped clamping member adapted to embrace said flanges and provided with cross pins that extend into said slots, an inner collapsible core consisting of a piece of sheet metal bent into approximately tubular shape and provided on its edges with interlocking flanges, a cruciform-shaped expanding member extending through said core, a funnel provided with a flange that fits inside of the upper end of the outer shell, a conical-shaped cap connected to said funnel for fitting over the upper end of the collapsible core, and a device provided with pins that project through openings in the outer shell and butt against the outer surface of said core; substantially as described.

6. An apparatus for the purpose described, comprising means for molding a round hollow post from concrete and forming a number of holes in said post, and a yielding

clamping member adapted to be arranged inside of said post for temporarily holding in position a plurality of wire connecting devices that are arranged in the openings in said post; substantially as described.

7. An apparatus for the purpose described, comprising an outer shell, an inner collapsible core arranged inside of same, a wooden expanding member of approximately cruciform shape in cross section extending through said core, a cup-shaped ring arranged inside of the outer shell at the lower end thereof, a funnel arranged at the upper end of the outer shell and provided with a conical-shaped cap that fits over the upper end of the inner core, means carried by said funnel for positioning a piece of reinforcing woven wire between the outer shell and core, and a bar arranged outside of the outer shell and provided with pins that project inwardly through openings in the outer shell; substantially as described.

8. An apparatus for the purpose described, comprising an outer shell consisting of a piece of sheet metal bent to form a tapered tube, flanges on said outer shell, means for clamping said flanges together, a base plate provided with a ring-shaped portion that embraces the lower end of said outer shell, a collapsible inner core consisting of a piece of sheet metal bent to form a tapered tube and provided on its longitudinal edges with interlocking flanges, a tapered expanding member extending through said core, a funnel arranged at the upper end of said outer shell and provided with a flange that fits inside of said shell, brackets inside of said funnel, a ring connected to said brackets and provided with a conical-shaped cap that closes the upper end of the inner core, said brackets having notches which receive the upper edge of a piece of woven wire that is adapted to be arranged between the outer shell and inner core, and a bar extending longitudinally of the outer shell and provided with pins that project inwardly through openings in said shell; substantially as described.

9. An apparatus for the purpose described, provided with means for holding a hollow round tapered fence-post, means for forming openings in said post during the operation of molding same for receiving fence wire connecting devices provided at their inner ends with eyes, and means adapted to be arranged inside of said post for temporarily holding said devices in a certain position while a rod is inserted through the eyes thereof; substantially as described.

In testimony whereof I hereunto affix my signature in the presence of two witnesses, this third day of December 1908.

JAMES W. MILLAM.

Witnesses:

WELLS L. CHURCH,  
GEORGE BAKEWELL.