

[54] AIR FRESHENER CONTAINER OR VAPOR
DIFFUSING DEVICE

3,104,816 9/1963 Jaffe 239/35
3,239,145 3/1966 Russo..... 239/35

[75] Inventors: William G. Crowle, Deerfield;
Efrem M. Ostrowsky, Highland
Park, both of Ill.

Primary Examiner—M. Henson Wood, Jr.
Assistant Examiner—Andres Kashnikow
Attorney, Agent, or Firm—Max R. Kraus; E. Donald
Mays

[73] Assignee: VCA Corporation, Baton Rouge,
La.

[22] Filed: July 5, 1974

[57] ABSTRACT

[21] Appl. No.: 485,943

A vapor diffusing device comprising a base and a closure or cover which are detachable from each other, the base having a bottom wall and an upstanding annular sidewall with the upstanding sidewall having spaced openings therein. Means on the interior of the upstanding sidewall providing a plurality of vertically spaced ledges. The cover is adapted to be positioned so that when it is in its fully lowered position the cover provides vapor sealing engagement with the base and when the cover is raised with respect to the base it is supported in its raised position on the vertically spaced ledges to provide vapor passages through the spaced openings.

[52] U.S. Cl. 239/58; 150/0.5; 239/60

[51] Int. Cl.² A61L 9/04

[58] Field of Search 239/34, 35, 55, 57, 58-60;
150/0.5; 206/0.5; 312/31, 31.1-31.3; 21/74
R, 74 A

[56] References Cited
UNITED STATES PATENTS

2,556,608	6/1951	Will	239/58 X
2,763,395	9/1956	Meek	239/58 X
2,765,950	10/1956	Wheeler.....	239/58 X

12 Claims, 9 Drawing Figures

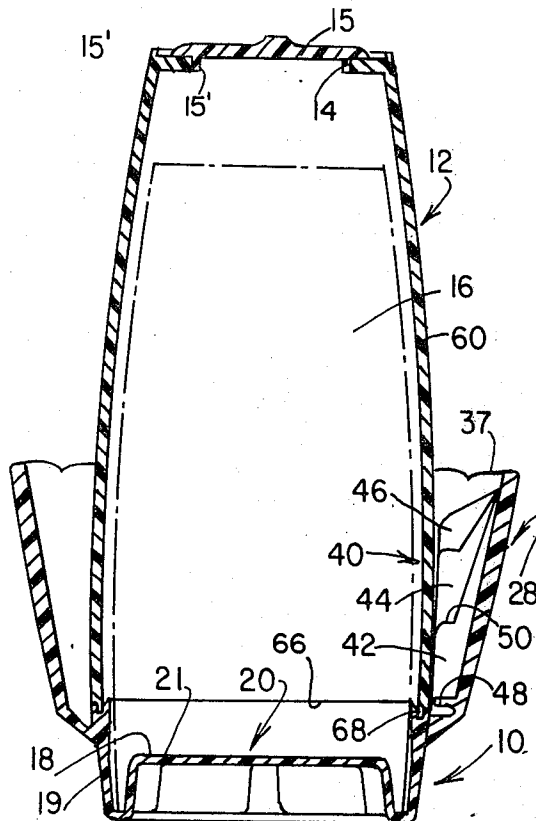

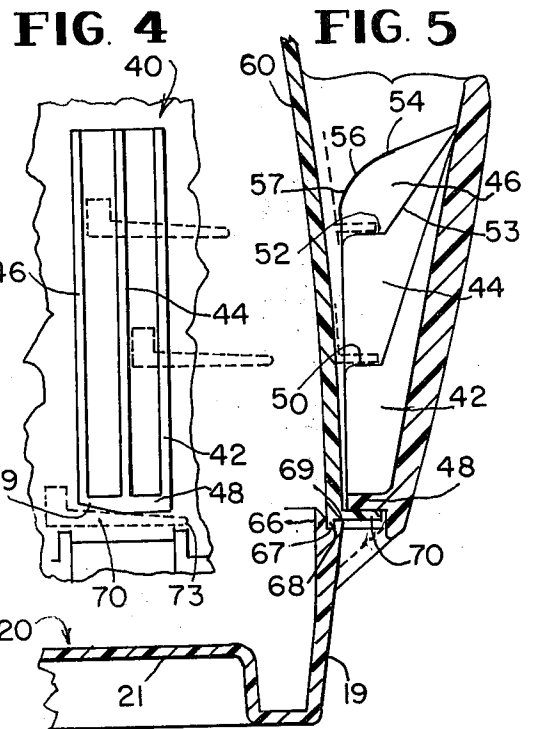
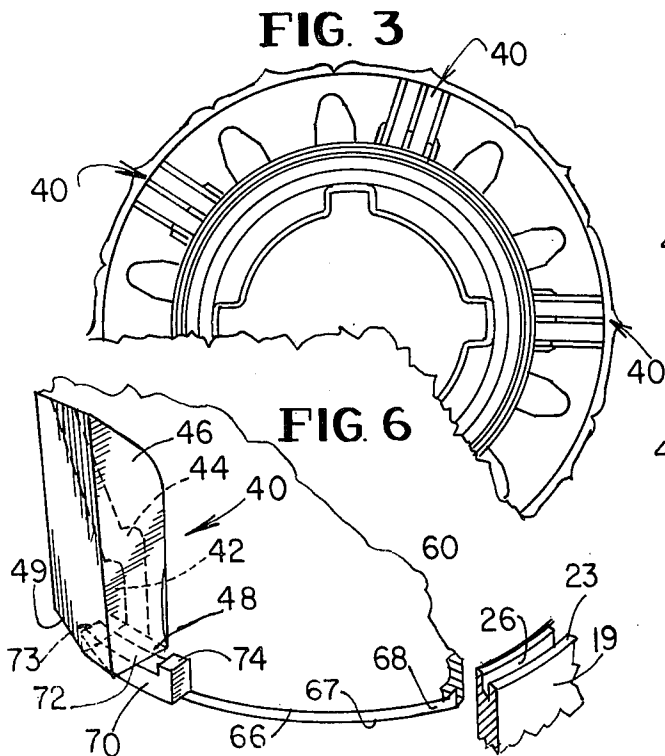
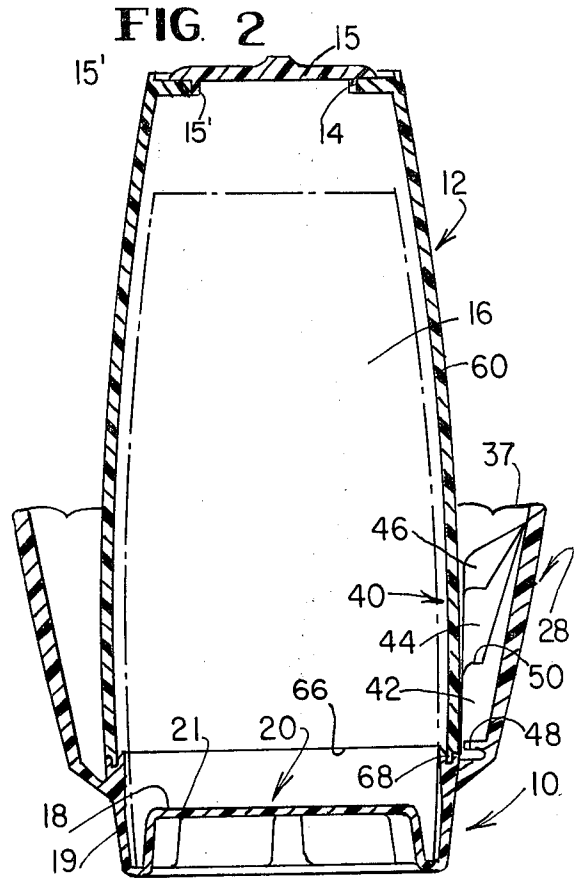
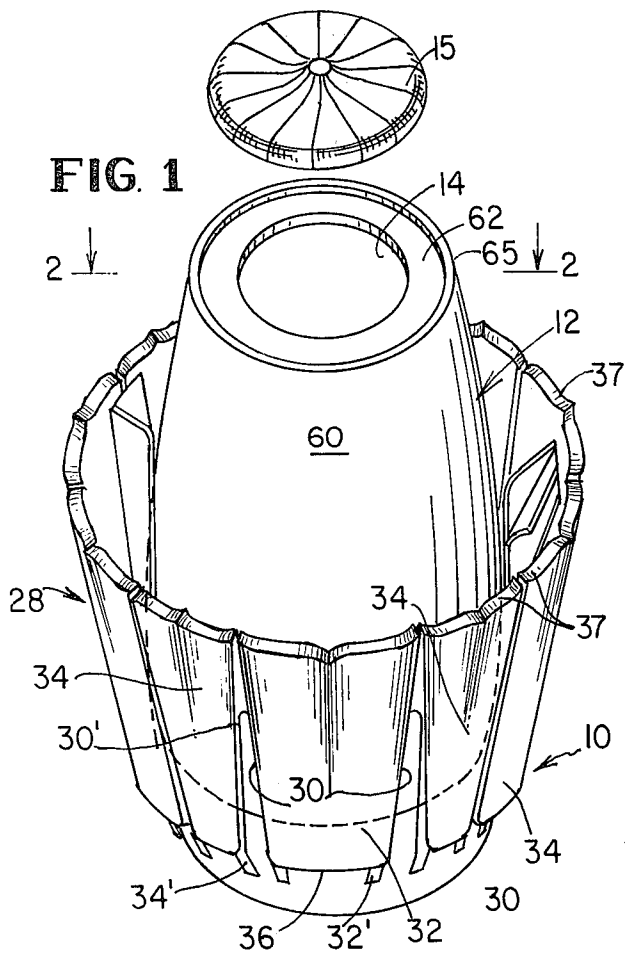

FIG. 7

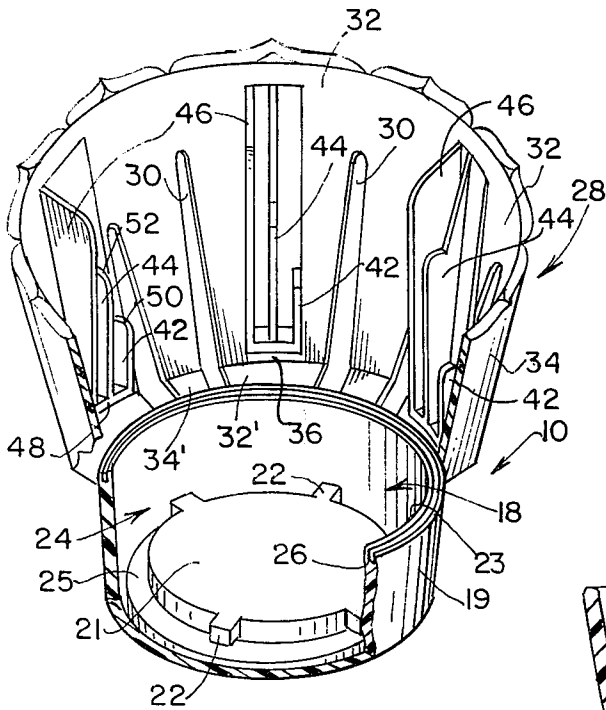

FIG. 8

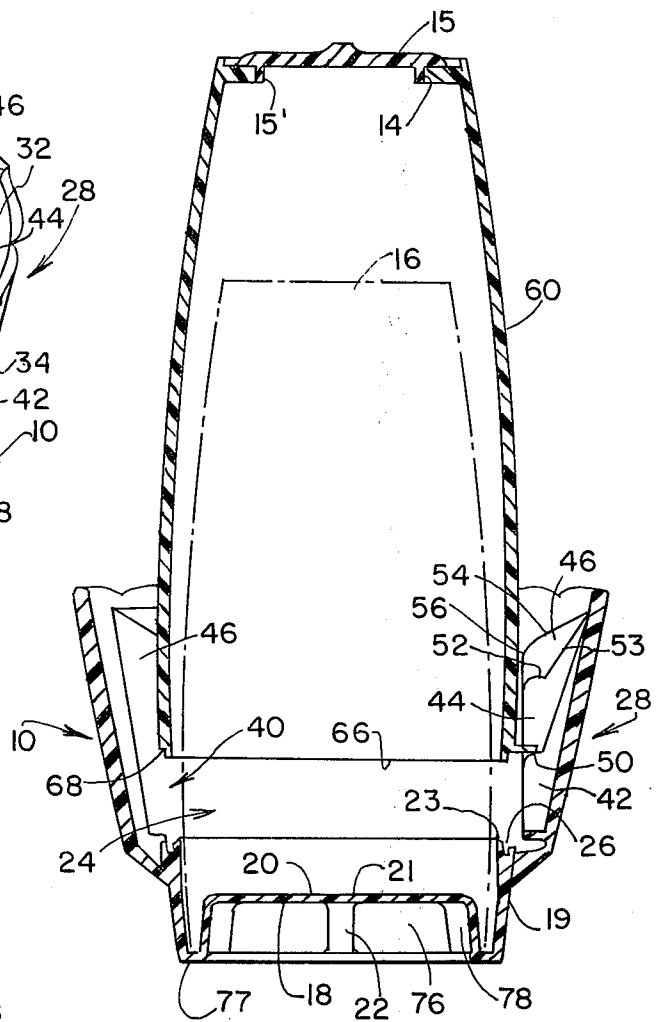
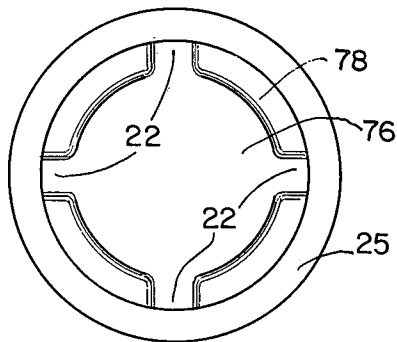

FIG. 9



AIR FRESHENER CONTAINER OR VAPOR DIFFUSING DEVICE

BRIEF SUMMARY OF THE INVENTION

This invention is directed to an air freshener container or vapor diffusing device comprising a base and a cover or closure member in which the base contains a volatile material, for example, an air freshening deodorizer, and in which the closure or cover is manually displaceable with respect to the base to provide means for controlling the effective rate of volatilization or evaporation of the air treatment agent, and also wherein the cover can be positively locked with respect to the base so that it is sealed with respect to the base to prevent evaporation or volatilization of the air treating agent.

Another object of this invention is to provide a device of the foregoing character where as the volatilization or evaporation takes place and as the air treating agent reduces in size and its appearance deteriorates or is destroyed that it will not be visible and will be practically hidden from exterior view.

Another object of this invention is to provide a device in which the cover may be adjusted relative to the base to a plurality of different elevated or raised positions which permits substantial control or variation of the rate of volatilization, while at the same time effectively locking the cover relative to the base during periods of non-use or during the period of shipment of same.

Another object of this invention is to provide a device of the foregoing character which is inexpensive to produce, substantially foolproof in operation and very attractive in appearance and appropriate for use in any environment where appearance is important.

BRIEF DESCRIPTION OF THE DRAWINGS

In the drawings:

FIG. 1 is a perspective view of the device in closed position, with the top disk of the closure member shown detached for illustrative purposes.

FIG. 2 is a central cross-sectional view showing the disk in locked sealing position.

FIG. 3 is a fragmentary top plan view looking down into the base member.

FIG. 4 is a fragmentary inside elevational view of the base member showing the three ribs.

FIG. 5 is an enlarged fragmentary sectional view showing the closure or cover locked to the base member.

FIG. 6 is a fragmentary perspective view showing the locking lug on the closure and its position when being moved into locking position on the base.

FIG. 7 is a broken-away perspective view showing particularly the interior of the base member.

FIG. 8 is a view similar to FIG. 2 and showing the cover resting in its first elevated position with respect to the base; and

FIG. 9 is a bottom plan view of the underside of the base.

The device consists essentially of two basic parts, namely, a base generally indicated at 10 and a cover or closure member generally indicated at 12, each of which is integrally molded of a plastic material. The cover 12 is molded to provide a top annular opening 14 which is closed by a disk 15, as shown in FIG. 2. The air treating material indicated at 16 and illustrated in

dotted lines, subsequently to be described, is held secured in the base 10. The base and cover are so constructed that the cover may be locked to the base in a vapor sealing position, as shown in FIG. 2, and when in use the cover 12 is elevated or raised with respect to the base 10 to various elevations to provide increased or decreased vapor passages which are formed in the base. One of such elevated positions is shown in FIG. 8.

The base 10 is generally cup-shaped and comprises a closed bottom generally indicated at 18 which consists of a lower annular side wall 19 and a horizontal bottom wall 20 which has an annular centrally raised bottom portion 21 with spaced radially extending bosses 22. The closed bottom forms a pocket 24 for receiving the air treating material, as will be subsequently described, so that it is secured to the base. The pocket 24 includes the annular well 25 between the annular side wall 19 and the centrally raised bottom portion 21. The top or rim 23 of the side wall 19 has an annular groove 26.

Extending upwardly of the lower annular side wall 19 is an upper annular side wall generally indicated at 28 which is provided with vertically extending spaced elongated openings 30 which form the vapor passages and which also divide the upper side wall into alternate side wall sections 32 and 34, with the wall section 32 being approximately twice the width of the wall section 34. The bottom of each wall section 32 has an opening 36 which also form vapor passages. The wall sections 32 and 34 forming the upper wall extend from below the top of the annular side wall 19 to the top edge which forms a scalloped-shaped rim 37 at the mouth of base member 10. The lower ends 32' and 34' of the wall sections 32 and 34, respectively, incline and the upper annular side wall 28 inclines or tapers outwardly from the bottom to the top rim 37 to give the upper annular wall an outwardly flared configuration. The vertical openings 30 forming the vapor passages have an elongated tapered appearance with the greatest width adjacent the bottom of the opening and the top 30' of the opening terminates a distance below the top edge or rim 37 of the cup or base.

The inside of the upper annular wall 28 of the base is provided with five groups of inwardly extending vertical ribs. Each group of ribs, generally indicated at 40, comprises three spaced ribs identified by the numerals 42, 44 and 46 which are of different lengths or heights. The first rib 42 of each group is the shortest, the third rib 46 the longest and the second or intermediate rib 44 of intermediate length. The bottoms of the three ribs are connected by a bottom horizontal locking strip 48 which is spaced upwardly of the rim 23 of the annular bottom side wall 19 and which locking strips are engaged by the locking lugs on the cover in a camming action to lock the cover in its sealing position, as best shown in FIGS. 4, 5 and 6, to be described. The end of the locking strip 48 adjacent the rib 46 is beveled as at 49, as best seen in FIG. 4, to facilitate engagement with the cover locking lugs.

The horizontal top edge 50 of the shortest rib 42 serves as a rest or ledge or support for the cover 12 in its first raised position, as best seen in FIG. 8. The horizontal top edge 52 of the second or intermediate rib 44 serves as a rest or ledge or support for the cover in its second or uppermost raised or elevated position. The second or intermediate rib 44 above the top horizontal

edge 52 is inclined as at 53 toward the wall. The third or longest rib 46 has a downwardly inclined top edge 54 which is rounded as at 56 as it merges with the front edge 57 of said rib. The third rib 46 serves to properly guide the cover into the base when it is inserted and in addition serves as a stop member, as will be subsequently described, as does the second or intermediate rib 44, more fully to be described in connection with the operation of the cover. The three spaced ribs 42, 44 and 46 of each group of ribs are formed on the wider side wall sections 32 of the upper portion of the base.

The cover or closure 12 is a shell-like member having a cylindrical-shaped body 60 with an annular ring-like tip wall 62 providing the central top opening 14 and open at its bottom. The top wall ring 62 is below the annular top edge 65 of the body 60. The cylindrical body 60 is provided with a slight taper which tapers inwardly from the bottom toward the top. The outer surface of the cylindrical body may be ornamented with lines or other configurations to enhance its appearance. The disk 15 has an annular peripheral lip or shoulder 15' to engage the top wall 62 when positioned thereon and sealed thereto, with a portion of the disk extending into the opening 14, as will be described.

The annular bottom edge 66 of the cylindrical body 60 is recessed as at 67 to provide a downwardly extending lip 68 and a horizontal shoulder 69 so that when the cover is positioned in sealing position on the base, the lip 68 enters the annular groove 26 of the rim 23 of the lower bottom of the base, as shown in FIGS. 2 and 5, to form a seal-tight fit therewith to prevent any vapor from escaping from the interior of the sealed container.

Immediately above the recessed lower rim of the cover is a plurality of spaced locking lugs generally indicated at 70. Five such locking lugs are shown for engagement with the five horizontal locking strips 48. As best seen in FIG. 6, the top 72 of each locking lug slopes or inclines upwardly from the front or lead edge 73 thereof toward the rear which terminates in an upward projection 74 which serves as a stop to prevent further continued rotation of the cover when in its fully closed or sealing position, as shown in FIG. 2. The locking lugs 70 act as cams so that rotation of the cover to lock the cover to the base in effect cams the locking lugs in locking position.

The underside of the closed bottom of the base is best seen in FIGS. 8 and 9. The raised bottom portion 21 also provides a recessed area 76 above the bottom edge 77 of the base 10 which opens downwardly and four arcuate-shaped bosses 78 are spacedly formed on the underside so that the base 10 may be positioned on a tool or the like to hold the base in position when the cover is initially secured to the base, which is done at the plant where the parts are molded, as will be better understood from the description of the operation which follows.

OPERATION

The operation of the device will be understood from the foregoing description, but briefly described is as follows.

After the air treating material 16 has been secured to the base 10 in the manner hereinafter described, the cover 12 is inserted into the base 10 with the locking lugs 70 positioned between each group of ribs 40. The third rib 46 of each group of ribs will serve to guide and properly position the lower edge of the cover relative

to the base to permit easy and accurate insertion. The lip 68 on the bottom edge 66 of the cover will enter the annular groove 26 on the rim 23 of the base with the shoulder 69 resting on the rim. To lock the cover to the base the cover is rotated clockwise with the front edge 73 of the locking lug 7 first passing under the beveled edge 49 of the horizontal locking strip 48. As the cover is rotated clockwise the sloping top surface 72 of the locking lug 70 cams the locking lugs into locking engagement with the horizontal locking strips 48 until the rear projections 74 of the locking lugs engage the rear edge of the locking strips 48 which prevents further clockwise rotation of the cover and thereby locks the cover to the base in a vapor-seal position, in which position it remains during shipment and when in non-use position prevents vapor from emanating from the device. In this lowered or sealing position the cover if rotated counterclockwise will still remain in vapor seal-proof closed position as the rear edge and projection 74 of the locking lugs will engage the bottom of the first or shortest ribs 42 and the opposite edge of the adjacent locking strips 48 to prevent further counterclockwise rotation. The cover, however, will not be in a locked position.

Assuming that the cover is in locked position with the locking lugs 70 locked to the locking strips 48 and the device is to be used, the cover is rotated counterclockwise until the locking lugs 70 are free of the locking strips 48. The cover is then raised or lifted to either first or second raised position as desired. For example, if desired to raise it to first position, as shown in FIG. 8, the cover is raised to the top edges 50 of the first ribs 42 and the cover is rotated counterclockwise so that the bottoms of the locking lugs 70 rest on the top edges 50 to support the cover in its first raised position. The rear edges and the projections 74 of the locking lugs will engage the intermediate ribs 44 and prevent or stop further counterclockwise rotation at this raised position. With the cover in first raised position (FIG. 8) the bottom of the cylindrical cover is above the sealing position of the cover, thus exposing the lower portions of the vapor openings 30 as well as openings 36 to permit vapor to pass through. When greater vaporization is desired the cover 12 is raised and rotated counterclockwise so that the locking lugs 70 rest on the ledges 52 of the intermediate ribs 44 and further counterclockwise rotation of the cover being prevented in this second raised position by engagement of the rear of the locking lugs with the third ribs 46.

To close the cover, the cover is rotated counterclockwise from any of its elevated positions so that the locking lugs are disengaged from their respective ledges and the cover is lowered to its lowermost position in the base and then rotated clockwise to locking position as described. While three ribs are shown for each group of ribs it will be understood that a fewer or greater number of ribs may be provided in each group of ribs if increased or decreased cover positions are desired.

Another feature of the invention herein is that as the cover is elevated and as the air treating material 16 in the base is used up due to its vaporization, there is no detracting from the appearance since the deteriorated or misshaped air treating material remaining in the base is substantially hidden from exterior view, even when the cover or closure is in either of its raised positions.

The manner in which the volatile material or deodorizing material is put into the unit will now be described.

The cover 12 without the disk 15 thereof is locked to the base 10 by means of lockings lugs, etc. as previously described. This leaves the top of the cover open and in this manner it is shipped to the company who will supply the volatile air treating agent, which agent is poured into the locked container through the opening 14 in the cover. The material will then fill and occupy the closed bottom 18 of the base, including the annular well 25 as well as the pocket 24 and will extend upwardly beyond the top of the base into the cover portion but be confined within the cover or closure. The material is allowed to solidify and harden and becomes embedded in the closed bottom 18 of the base and adheres thereto. The bosses 22 serve to lock the hardened deodorizing material in the base so as to prevent rotation of the hardened deodorizing material when the cover is rotated. While the deodorizing material when initially poured into the cover will occupy the interior space of the cylindrical body of the cover, it will reduce in size as it hardens so that it disengages from the inside wall of the cylindrical wall of the cover so that the cover can be rotated without disturbing the hardened deodorizing material. The disk 15 is then permanently secured to close the opening 14 in the cover in any conventional manner.

What is claimed is:

1. A vapor diffusing device comprising a base and a closure or cover which are detachable from each other, said base having a bottom wall and an upstanding annular side wall with said upstanding sidewall having spaced openings therein, means on the interior of said upstanding sidewall providing a plurality of vertically spaced apart ledges, said cover adapted to be positioned so that when in its fully lowered position the cover provides vapor sealing engagement with said base and when said cover is raised with respect to said base it is supported in its raised position on said vertically spaced ledges to provide vapor passages through said spaced openings.

2. A device as set forth in claim 1 in which said vertically spaced apart ledges are a plurality of grouped vertical, radially spaced apart ribs and in which certain of said ribs in each of said group also provide a stop means to prevent further rotation of the closure in one direction while resting on the ledges.

3. A device as set forth in claim 1 in which the cover has locking lugs adapted to engage means on the base for detachably locking said cover to said base in a vapor sealing position.

4. A device as set forth in claim 3 in which the locking lugs are adapted to rest on said vertically spaced ledges to hold the cover in elevated or raised position relative to the base.

5. A device as set forth in claim 2 in which the cover has locking lugs adapted to engage means on the base for detachably locking said cover to said base in a vapor sealing position and in which said locking lugs are adapted to rest on the ribs to maintain the cover at different elevated positions with adjacent ribs of each group providing stop means to prevent further rotation of the closure in one direction while resting on the ledges, the positioning of said cover at different elevated positions serving to provide increased or decreased vapor passages through said spaced openings.

6. A device as set forth in claim 2 in which each group of said radially spaced ribs comprises at least three ribs with the first and second ribs having the tops thereof at different heights to serve as ledges for supporting the cover in two raised positions and with the second rib and the third rib also preventing rotation of the cover in one direction while resting on the first rib and second rib respectively, and with the top of the third rib extending above the top of the second rib.

7. A device as set forth in claim 6 in which the third rib also serves to guide the cover when it is inserted into the base.

8. A device as set forth in claim 6 in which the cover has locking lugs with sloping tops which when the cover is rotated clockwise lock in a camming action with the means on the base to hold the cover in fully closed and vapor sealing position.

9. A device as set forth in claim 8 in which the base has an annular groove which receives the annular lip on the bottom of the cover when the cover is in vapor sealing position.

10. A device as set forth in claim 9 in which the bottom wall of the base has a centrally raised bottom portion defining a well and provided with bosses to which the deodorizing material is secured when it hardens.

11. A device as set forth in claim 6 in which the underside of the base has a recessed portion which has inwardly extending bosses for holding the base while the cover is initially secured thereto in a locked position.

12. A device as set forth in claim 1 in which said cover has an opening in its upper end and means for closing said upper end opening.

* * * * *

50

55

60

65