



(43) International Publication Date
18 October 2012 (18.10.2012)

- (51) International Patent Classification:
B65D 51/22 (2006.01) *B01F 13/00* (2006.01)
B01L 3/00 (2006.01)
- (21) International Application Number:
PCT/US2012/032865
- (22) International Filing Date:
10 April 2012 (10.04.2012)
- (25) Filing Language: English
- (26) Publication Language: English
- (30) Priority Data:
13/086,180 13 April 2011 (13.04.2011) US
- (71) Applicant (for all designated States except US): **GENERAL ELECTRIC COMPANY** [US/US]; 1 River Road, Schenectady, NY 12345 (US).
- (72) Inventors; and
- (75) Inventors/Applicants (for US only): **SAMPER, Victor, Donald** [GB/DE]; General Electric Company Global Research, One Research Circle, Bldg. K1-3A59, Niskayuna, NY 12309 (US). **FRANCI, Xavier** [BE/BE]; General Electric Company Global Research, One Research Circle, Bldg. K1-3A59, Niskayuna, NY 12309 (US). **BOELD, Christoph** [DE/DE]; General Electric Company Global Research, One Research Circle, Bldg. K1-3A59, Niskayuna, NY 12309 (US). **RENSCH, Christian, Friedrich, Peter** [DE/DE]; General Electric Company Global Research, One Research Circle, Bldg. K1-3A59, Niskayuna, NY 12309 (US).
- (74) Agents: **THOMAS, Jonathan, E.** et al.; General Electric Company, Global Patent Operation, 2 Corporate Drive, Suite 648, Shelton, CT 06484 (US).

- (81) Designated States (unless otherwise indicated, for every kind of national protection available): AE, AG, AL, AM, AO, AT, AU, AZ, BA, BB, BG, BH, BR, BW, BY, BZ, CA, CH, CL, CN, CO, CR, CU, CZ, DE, DK, DM, DO, DZ, EC, EE, EG, ES, FI, GB, GD, GE, GH, GM, GT, HN, HR, HU, ID, IL, IN, IS, JP, KE, KG, KM, KN, KP, KR, KZ, LA, LC, LK, LR, LS, LT, LU, LY, MA, MD, ME, MG, MK, MN, MW, MX, MY, MZ, NA, NG, NI, NO, NZ, OM, PE, PG, PH, PL, PT, QA, RO, RS, RU, RW, SC, SD, SE, SG, SK, SL, SM, ST, SV, SY, TH, TJ, TM, TN, TR, TT, TZ, UA, UG, US, UZ, VC, VN, ZA, ZM, ZW.
- (84) Designated States (unless otherwise indicated, for every kind of regional protection available): ARIPO (BW, GH, GM, KE, LR, LS, MW, MZ, NA, RW, SD, SL, SZ, TZ, UG, ZM, ZW), Eurasian (AM, AZ, BY, KG, KZ, MD, RU, TJ, TM), European (AL, AT, BE, BG, CH, CY, CZ, DE, DK, EE, ES, FI, FR, GB, GR, HR, HU, IE, IS, IT, LT, LU, LV, MC, MK, MT, NL, NO, PL, PT, RO, RS, SE, SI, SK, SM, TR), OAPI (BF, BJ, CF, CG, CI, CM, GA, GN, GQ, GW, ML, MR, NE, SN, TD, TG).

Declarations under Rule 4.17:

- as to applicant's entitlement to apply for and be granted a patent (Rule 4.17(ii))
- as to the applicant's entitlement to claim the priority of the earlier application (Rule 4.17(iii))

Published:

- with international search report (Art. 21(3))
- before the expiration of the time limit for amending the claims and to be republished in the event of receipt of amendments (Rule 48.2(h))

(54) Title: INTERFACING CAPS FOR MICROFLUIDIC DEVICES AND METHODS OF MAKING AND USING THE SAME

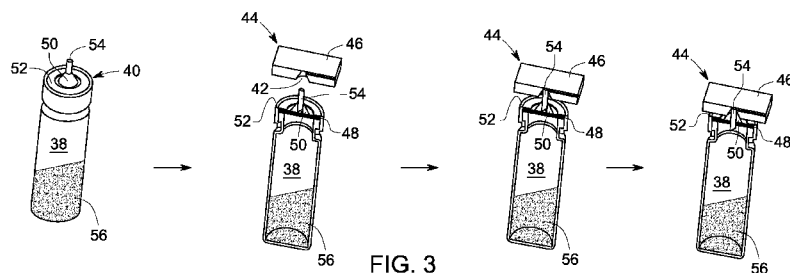

(57) Abstract: An interfacing cap for a reagent storage vessel is provided. The interfacing cap comprises a partitioning element having a structure corresponding to an opening of the reagent storage vessel, a projection fitting disposed on the partitioning element, a holder element, and a puncturing element coupled to the projection fitting.

INTERFACING CAPS FOR MICROFLUIDIC
DEVICES AND METHODS OF MAKING AND
USING THE SAME

CROSS-REFERENCE TO RELATED APPLICATION

[0001] The present invention is a continuation-in-part of and claims priority to U.S. Patent Application No. 12/844,385, filed July 27, 2010.

BACKGROUND

[0002] Embodiments of the invention relate to microfluidic devices, and more particularly, to interfacing devices for introducing fluids in the microfluidic devices.

[0003] For analytical analysis or preparative steps, reagents are stored in storage containers or vials and need to be transferred to a microfluidic device for carrying out analysis. Conventionally, a reagent storage vial is filled with a reagent volume, and the reagent storage vial is closed using a septum that is disposed on the opening of the reagent storage vial. The septum is held in place using a holder, such as a crimp cap. During analysis or preparation procedures, the septum is punctured and the reagent is transferred in the microfluidic device. The septum may be punctured using a needle at the point of use. The puncturing of the septum makes a fluid and gas seal up to approximately 2 bar over-pressure. Further, puncturing of the septum prior to interfacing the storage container with the microfluidic device results in oozing or spilling of the reagents outside the vial.

[0004] Therefore, there exists a need for an interfacing cap for interfacing storage containers with microfluidic devices for preventing or minimizing the leak of reagents of the storage containers during the transfer of the reagent from the storage container to the microfluidic device.

BRIEF DESCRIPTION

[0005] In one embodiment, an interfacing cap for a reagent storage vessel is provided. The interfacing cap comprises a partitioning element having a structure corresponding to an opening of the reagent storage vessel, a projection fitting disposed on the partitioning element, a holder element, and a puncturing element coupled to the projection fitting.

[0006] In another embodiment, a microfluidic device assembly is provided. The microfluidic device assembly comprises a device substrate comprising a conformal recess; an interfacing cap to interface a reagent storage vessel with the device substrate. The interface cap comprises a partitioning element having a structure corresponding to an opening of the reagent storage vessel, a projection fitting disposed on the partitioning element, a holder element, and a puncturing element coupled to the projection fitting.

[0007] In yet another embodiment, a method of making an interfacing cap is provided. The method comprises disposing a partitioning element on an opening of a reagent storage vessel, disposing a projection fitting on the device substrate, disposing at least a portion of the holder element on a portion of the partitioning element and on a portion of the projection fitting to hold the partitioning element and the projection fitting in place on the reagent storage vessel, and coupling a puncturing element to the projection fitting.

DRAWINGS

[0008] These and other features, aspects, and advantages of the present invention will become better understood when the following detailed description is read with reference to the accompanying drawings in which like characters represent like parts throughout the drawings, wherein:

[0009] FIG. 1 is a pictorial flow chart of an example of a method of making the interfacing cap;

[0010] FIG. 2 is a perspective view of an embodiment of a reagent storage vessel comprising an interfacing cap having an sealing element; and

[0011] FIG. 3 is an example of a method of making a microfluidic device assembly.

DETAILED DESCRIPTION

[0012] One or more of the embodiments of the interfacing devices of the invention enable microfluidic devices to efficiently interface with an external fluidic component. In one embodiment, the external fluidic component may be a reagent storage vessel, such as a vial. The reagent storage vessel may be used for introducing or extracting fluids (liquids or gases) from the fluidic devices, such as microfluidic devices.

[0013] In certain embodiments, the interfacing cap may comprise a partitioning element configured to be disposed on an opening of a reagent storage vessel, a projection fitting disposed on the partitioning element, a holder element configured to seal the partitioning element between the projection fitting and the vial, and a puncturing element coupled to the projection fitting, wherein the puncturing element is configured to puncture the partitioning element. In certain embodiments, the interfacing cap may be a disposable cap.

[0014] The projection fitting of the interfacing cap may be configured to interface the reagent storage vessel with a conformal recess of the microfluidic device. The puncturing element may be at least partially disposed in the projection fitting. The puncturing element is configured to perforate the partitioning element, and form a sealing with the conformal recess. The puncturing element may, for example, be a needle or a section of a capillary tube. The reagent may be transferred from the vessel to the microfluidic device via the puncturing element.

[0015] FIG. 1 illustrates an example of a method of making the interfacing cap of the invention. A reagent storage vessel 10 is filled with the desired reagent 12 under determined environment and atmosphere. A partitioning element 14 may be disposed

on an opening 15 of the reagent storage vessel 10. The partitioning element 14 may be made of silicone, polypropylene, polytetrafluoroethylene (TEFLON®), an elastomer, rubber (e.g., natural rubber), or combinations thereof. In one embodiment, the partitioning element 14 may be a re-sealable elastomeric element.

[0016] A projection fitting 16 is disposed on the partitioning element 14. The projection fitting 16 may be chosen to resemble the counter cone shape of the conformal recess in which the interfacing cap is to be disposed. In one embodiment, the projection fitting 16 may comprise a tapered geometry. The projection fitting 16 may comprise a cone 18 surrounded by a base 20. At least a portion of the base 20 may be in physical contact with the partitioning element 14. A holder element 22 is used to hold the partitioning element 14 and the projection fitting 16 in place on the vessel 10. In one example, the holder element 22 may be a crimp cap, a screw cap or a glue cap.

[0017] The material of the projection fitting 16 may be chosen based on the deformation properties (elastic or plastic deformation) of the material, or values of the temperature and pressure, and type of fluids to which the fluid connector device may be exposed. The materials of the projection fitting 16 and/or a device substrate, of the microfluidic device in which the conformal recess is disposed, are adapted to undergo at least partial deformation. In certain embodiments, the materials of the projection fitting 16 and device substrate may comprise glass, metals, semiconductors, ceramics, polymers, or combinations thereof. The material of the device substrate may be selected to allow one or more conformal recesses to be formed in the coupling substrate. The material of the device substrate may be chosen based on the ease of formation of the desired recess shape in the substrate material. For example, it may be easier to form a conical or a tapered recess in a polymer substrate than in a metal substrate, semiconductor substrate, or ceramic substrate, such as a glass substrate. The polymers for the device substrate and/or the projection fitting 16 may be soft polymers or hard polymers. Soft polymers refer to elastomer type materials such as, but not limited to, polydimethylsiloxane, copolymer of hexafluoropropylene (HFP) and vinylidene fluoride (VDF or VF₂), terpolymer of tetrafluoroethylene (TFE), vinylidene fluoride (VDF), and hexafluoropropylene (HFP),

perfluoromethylvinylether (PMVE), nitrile rubber, and thermoplastic elastomers such as ELASTRON® and THERMOLAST®. Hard polymers refer to materials such as, but not limited to, polyether ether ketone (PEEK), polypropylene, poly(methyl methacrylate) (PMMA), polyethelene, olefin copolymers (e.g. TOPAS®), modified ethylene-tetrafluoroethylene) fluoropolymer (ETFE) (e.g. TEFZEL®), polyetherimide (e.g. ULTEM®), cyclic olefin copolymer (COC), and the like.

[0018] A portion of a puncturing element 24 may be disposed in the cone 18 of the projection fitting 16. In one embodiment, the puncturing element 24 may be disposed in the cone 18 after disposing the projection fitting 16 on the partitioning element. In this embodiment, the puncturing element 24 may be disposed in the cone 18 either before or after disposing the holder element on the projection fitting 16 and the partitioning element 14. In another embodiment, the puncturing element 24 may be disposed in the cone 18 prior to disposing the projection fitting 16 on the partitioning element 14. In one example, the puncturing element 24 may be coupled to the projection fitting 16 by pressing the puncturing element 24 against the cone 18. The puncturing element 24 may be a needle or a small section of a capillary.

[0019] When the vessel 10 having the interfacing cap is pressed against a microfluidic device, the puncturing element 24 may be first pushed backwards into the projection fitting 16 and up to the partitioning element 14, thereby puncturing the partitioning element 14. Upon further pressing of the vessel 10 against the microfluidic device, the puncturing element 24 is sealed to the microfluidic device due to deformation of the material of the conformal recess. The conformal recess or the projection fitting 16, or both may undergo either elastic or plastic deformation to provide a seal between the projection fitting 16 and the device substrate. In one example, only the conformal recess may undergo deformation, for example, an elastic deformation. In another example, both the conformal recess and the projection fitting 16 may undergo deformation. In this example, the conformal recess may undergo elastic deformation, and the reconnectable fit projection fitting 16 may undergo plastic deformation. After formation of the sealing and the puncturing of the partitioning element 14, the vessel 10 is directly coupled to the microfluidic device.

[0020] FIG. 2 illustrates an interfacing cap 30 comprising a sealing element 32. The sealing element 32 may be disposed either on the interfacing cap 30 or on the microfluidic device (not shown). In embodiments, where the sealing element 32 is disposed on the interfacing cap 30, the sealing element may be disposed around the cone 18 of the projection fitting 16. The sealing element 32 may be disposed on the base 20 of the projection fitting 16. The sealing element 32 may be in the form of an annular cylinder. The height of the cylinder may be smaller or greater than the height of the interfacing cap 30. The sealing element 32 is configured to provide sealing between the conformal recess of the microfluidic device and the interfacing cap 30 even before the interfacing cap 30 during (and after) coupling of the interfacing cap 30 and the conformal recess. Non-limiting examples of the sealing element 32 may include an elastomer. In embodiments where the sealing element 32 is disposed on the microfluidic device, the sealing element may be disposed about the conformal recess in which the interfacing cap is configured to be disposed.

[0021] When the reagent needs to be transferred from the vessel 10 to the microfluidic device, the vessel 10 may be disposed on the conformal recess of the microfluidic device. Upon pressing the vessel 10 against the microfluidic device, the sealing element 32 forms an initial soft seal between the vessel 10 and the microfluidic device (not shown) while allowing a first end 34 of the puncturing element 24 to push against the microfluidic device. The reagent storage vessel 10 may be pressed against the microfluidic device, as a result of the force being exerted on the conformal recess (not shown) of the microfluidic device, the first end 34 of the puncturing element 24 forms a sealing with the conformal recess.

[0022] After the first end 34 forms the sealing with the puncturing element 24, and upon continued pressing of the , the projection fitting 16 may slide on the puncturing element 24 thereby reducing the distance between the second end (not shown) of the puncturing element 24 and the partitioning element 14. As a result, the puncturing element 24 punctures the partitioning element 14.

[0023] In certain embodiments, the sealing element 32 may be an optional element for preventing or minimizing leaks that may otherwise occur upon puncturing of the

partitioning element 14 and before sealing of the interfacing cap 30 with the conformal recess of the microfluidic device. For example, the sealing element 32 may not be desired while using a reagent storage vessel with dry reagents. The soft seal may also be optional in embodiments where the system is arranged such that no fluid leaks out of the vessel after puncturing the partitioning element 14. For example, in instances where the fluid in the vessel may not flow out of the vessel upon puncturing of the partitioning element 14 as the flow of the fluid may result in a pressure inside the vessel that is lower than the ambient pressure. In some instances, the ambient pressure may be higher than atmospheric pressure.

[0024] FIG. 3 illustrates the steps in the method of sealing the reagent storage vessel 38 comprising an interfacing cap 40 with a conformal recess 42 of a microfluidic device 44. A microfluidic device substrate 46 comprising a conformal recess 42 is disposed near the reagent storage vessel 38 is such that the conformal recess 42 is aligned with the interfacing cap 40. The interfacing cap 40 comprises a partitioning element 48, a projection fitting 50, a holder component 52, and a puncturing element 54.

[0025] In one embodiment, the conformal recess 42 may not be pre-formed in the device substrate 46 prior to receiving the projection fitting 50 of the interfacing cap 40. In this embodiment, the material of the device substrate 46 may be configured to undergo thermal or pressure induced material yielding while receiving the projection fitting 50. That is, when the projection fitting 50 is pressed against the device substrate 46, the yielding of the device substrate 46 in and around the area that receives the projection fitting 50 may form a conformal recess. The conformal recess so formed may have a fluid tight seal with the projection fitting 50. In another embodiment, the material of the projection fitting 50 may be configured to undergo thermal or pressure induced material yielding while being disposed in a conformal recess 42.

[0026] Optionally, the conformal recess 42, and/or the tapered geometry of the projection fitting 50 that is configured to be disposed in the conformal recess may include a surface modification. The surface modification may be present either in a

portion, or the entire surface of the conformal recess 42 and/or the tapered geometry of the projection fitting 50. In embodiments where the conformal recess is not performed in the coupling substrate, the portion of the coupling substrate that is supposed to undergo deformation upon receiving the projection fitting to form the conformal recess may include surface modification. In one example, the surface modifications may be provided to improve the coupling between the projection fitting and the coupling substrate to reduce or eliminate any leaks. Non-limiting examples of types of surface modifications may include a soft coating, a hard coating, a hydrophobic material, an adhesive, a high roughness surface (such as a plasma etched, or a reactive ion etched surface), a low roughness surface (such as a coated area or polished area), physical features, such as threads. The type of surface modifications may depend on the type of material being employed for the projection fitting and the coupling substrate.

[0027] The interfacing cap 40 is disposed on the conformal recess 42, and the vessel 38 is pressed against the microfluidic device 44. The puncturing element 54 is pushed against the partitioning element and punctures the partitioning element 48. Subsequently, the puncturing element 54 forms a sealing with the conformal recess 42. Further compression then results in the projection fitting 50 being disposed in the conical recess 42. At this stage, the vessel 38 is in communication with the microfluidic device 44, and the reagents 56 may be transferred from the vessel 38 to the device 44 with low dead volume arrangement.

[0028] Advantageously, the interfacing cap provides a reliable fluid seal and may be configured to reduce the internal dead volume of standard vessels. In addition, the interfacing cap is a low cost device that can be fabricated easily. Also, the interfacing cap may be able to withstand high pressures, while maintaining low dead volume. In one example, the fluid tight seal provided by the interfacing cap may be configured to withstand pressures of over 1000 bars. The fluid connector device may be used with many types of microfluidic devices and with the incorporation of packaging that is easy to design and manufacture. Other advantages include easy installation, quick connection with no tools required, small footprint, leak-tight, and high working pressures.

[0029] While only certain features of the invention have been illustrated and described herein, many modifications and changes will occur to those skilled in the art. It is, therefore, to be understood that the appended claims are intended to cover all such modifications and changes as fall within the true spirit of the invention.

CLAIMS:

1. An interfacing cap for a reagent storage vessel having an opening, comprising:

a partitioning element having a structure corresponding to an opening of the reagent storage vessel;

a projection fitting disposed on the partitioning element;

a holder element; and

a puncturing element coupled to the projection fitting.
2. The interfacing cap of claim 1, wherein the projection fitting interfaces with a conformal recess of a fluidic device.
3. The interfacing cap of claim 1, wherein the puncturing element is at least partially disposed in the projection fitting.
4. The interfacing cap of claim 1, wherein the puncturing element comprises a needle or a capillary tube.
5. The interfacing cap of claim 1, wherein the sealing element is disposed on the interfacing cap.
6. The interfacing cap of claim 5, wherein the sealing element is annular.

7. The interfacing cap of claim 1, wherein the sealing element is disposed on a microfluidic device.

8. The interfacing cap of claim 1, wherein the reagent storage vessel comprises dry reagents.

9. The interfacing cap of claim 1, wherein the partitioning element comprises silicone, polypropylene, polytetrafluoroethylene, an elastomer, or combinations thereof.

10. The interfacing cap of claim 1, wherein the projection fitting comprises a metal, a semiconductor, a ceramic, a polymer, or combinations thereof.

11. A microfluidic device assembly, comprising:

a device substrate comprising a conformal recess;

an interfacing cap to interface a reagent storage vessel with the device substrate; the interface cap comprising:

a partitioning element having a structure corresponding to an opening of the reagent storage vessel;

a projection fitting disposed on the partitioning element;

a holder element; and

a puncturing element coupled to the projection fitting.

12. The microfluidic device assembly of claim 11, further comprising a sealing element disposed between the reagent storage vessel and the microfluidic device.

13. The microfluidic device assembly of claim 11, wherein the sealing element is disposed on the interfacing cap, the device substrate, or both.

14. The microfluidic device assembly of claim 11, wherein the holder element comprises a crimp cap, screw cap or glue cap.

15. The microfluidic device assembly of claim 11, wherein the projection fitting comprises a cone and a base.

16. The microfluidic device assembly of claim 11, wherein the conformal recess, the projection fitting, or both comprises a surface modification.

17. A method of making an interfacing cap; comprising:

disposing a partitioning element on an opening of a reagent storage vessel;

disposing a projection fitting on the device substrate;

disposing at least a portion of the holder element on a portion of the partitioning element and on a portion of the projection fitting to hold the partitioning element and the projection fitting in place on the reagent storage vessel;
and

coupling a puncturing element to the projection fitting.

18. The method of claim 17, wherein coupling the puncturing element comprises partially disposing the puncturing element in the projection fitting.

19. The method of claim 17, further comprising providing a sealing element for forming a soft seal between the device substrate and the projection fitting.

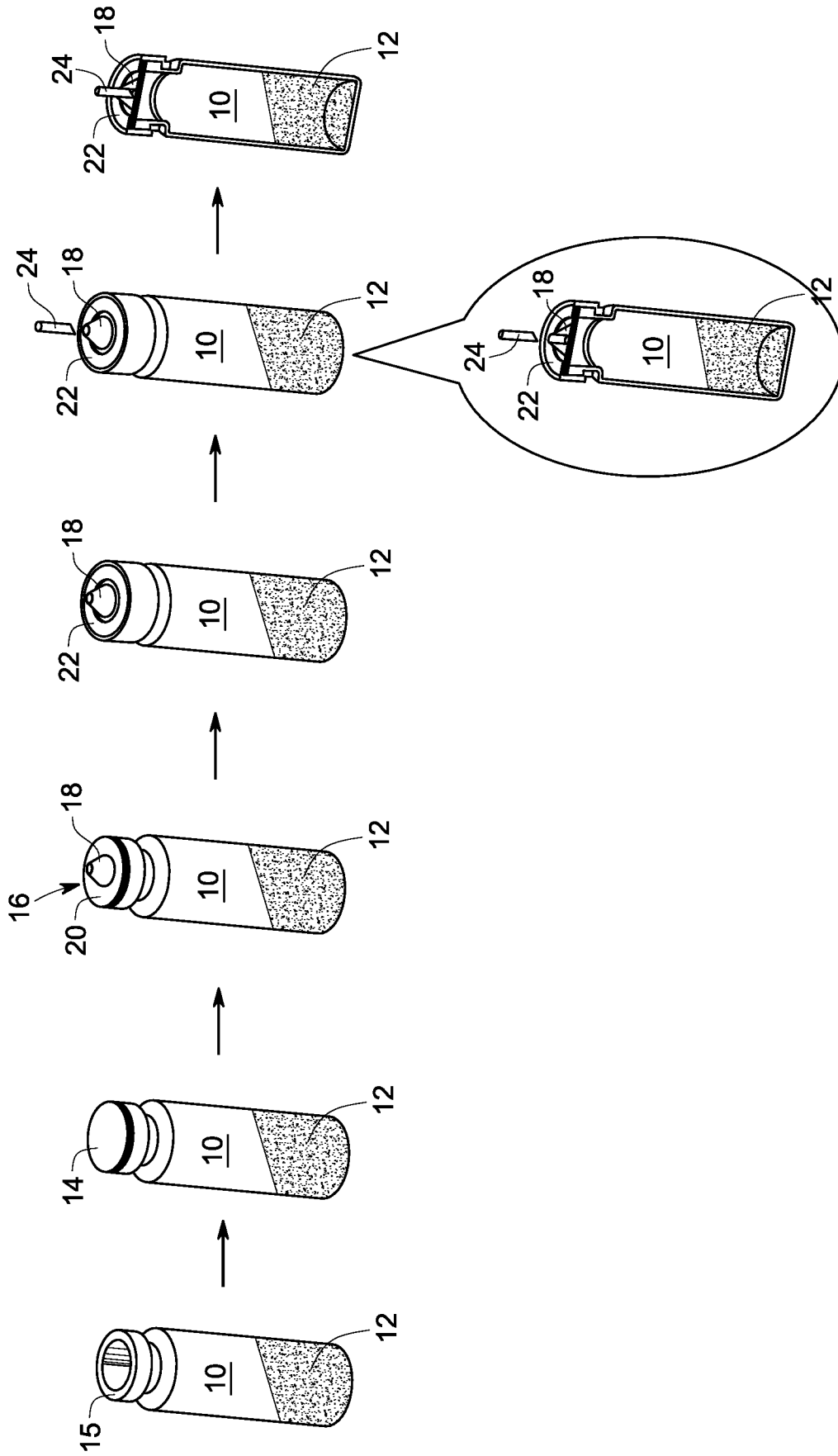

FIG. 1

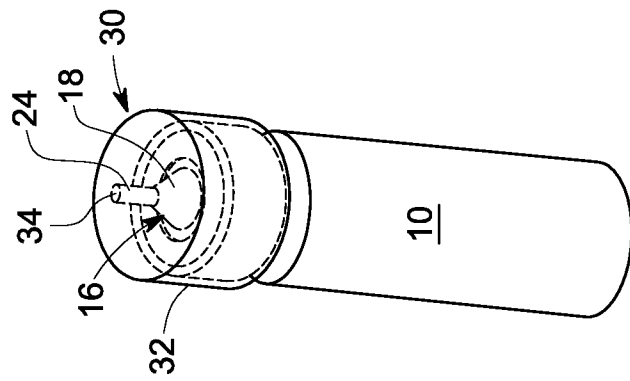

FIG. 2

3/3

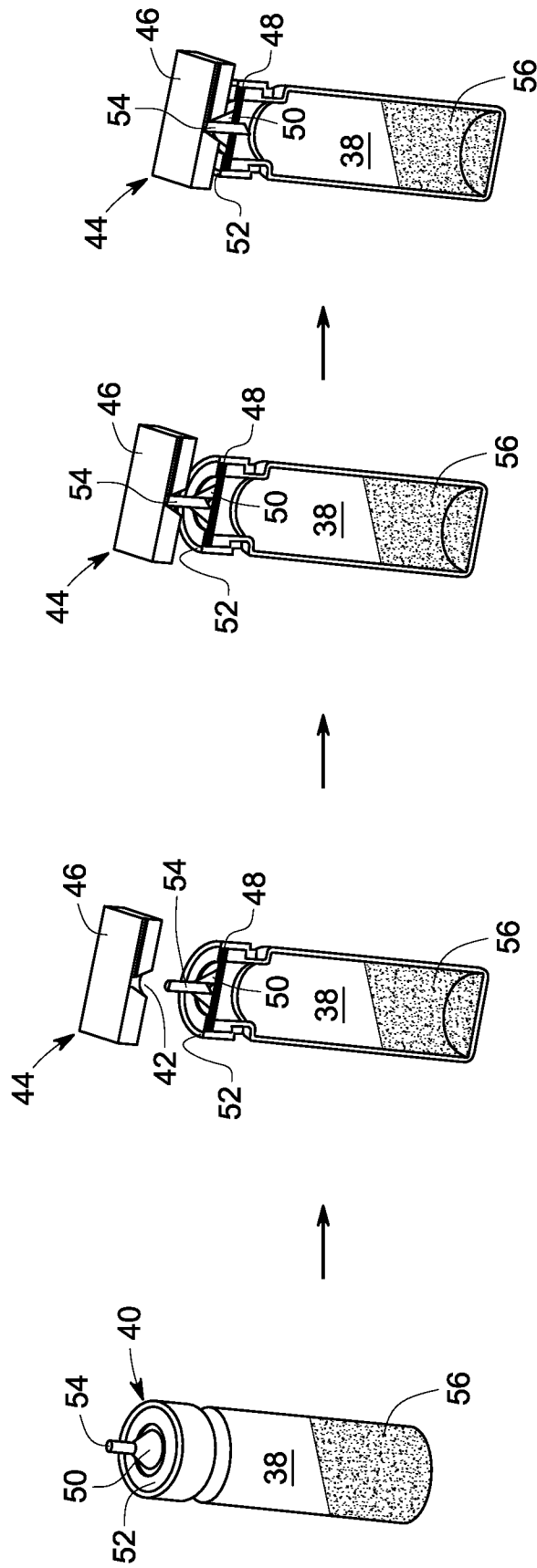

FIG. 3

INTERNATIONAL SEARCH REPORT

International application No
PCT/US2012/032865

A. CLASSIFICATION OF SUBJECT MATTER
INV. B65D51/22 B01L3/00 B01F13/00
ADD.
According to International Patent Classification (IPC) or to both national classification and IPC

B. FIELDS SEARCHED
Minimum documentation searched (classification system followed by classification symbols)
B01L B65D B01F

Documentation searched other than minimum documentation to the extent that such documents are included in the fields searched

Electronic data base consulted during the international search (name of data base and, where practicable, search terms used)
EPO-Internal, WPI Data

C. DOCUMENTS CONSIDERED TO BE RELEVANT

Category*	Citation of document, with indication, where appropriate, of the relevant passages	Relevant to claim No.
X	EP 1 909 089 A1 (NIPRO CORP [JP]) 9 April 2008 (2008-04-09) paragraphs [0003], [0011], [0012], [0022]; figures 1-8 -----	1-6, 8-10,17, 18
X	US 2005/014273 A1 (DAHM MICHAEL WERNER [DE] ET AL DAHM MICHAEL [DE] ET AL) 20 January 2005 (2005-01-20) paragraphs [0095], [0127], [0167], [0284]; figures 1-9 -----	1-6, 8-10,17, 18
X	EP 1 995 182 A1 (HOFFMANN LA ROCHE [CH]) 26 November 2008 (2008-11-26) paragraphs [0022] - [0032]; figures 1-4 ----- -/--	1-6, 8-10,18

Further documents are listed in the continuation of Box C.

See patent family annex.

* Special categories of cited documents :

"A" document defining the general state of the art which is not considered to be of particular relevance

"E" earlier application or patent but published on or after the international filing date

"L" document which may throw doubts on priority claim(s) or which is cited to establish the publication date of another citation or other special reason (as specified)

"O" document referring to an oral disclosure, use, exhibition or other means

"P" document published prior to the international filing date but later than the priority date claimed

"T" later document published after the international filing date or priority date and not in conflict with the application but cited to understand the principle or theory underlying the invention

"X" document of particular relevance; the claimed invention cannot be considered novel or cannot be considered to involve an inventive step when the document is taken alone

"Y" document of particular relevance; the claimed invention cannot be considered to involve an inventive step when the document is combined with one or more other such documents, such combination being obvious to a person skilled in the art

"&" document member of the same patent family

Date of the actual completion of the international search 7 September 2012	Date of mailing of the international search report 19/09/2012
---	--

Name and mailing address of the ISA/ European Patent Office, P.B. 5818 Patentlaan 2 NL - 2280 HV Rijswijk Tel. (+31-70) 340-2040, Fax: (+31-70) 340-3016	Authorized officer Viskanic, Martino
--	---

INTERNATIONAL SEARCH REPORT

International application No
PCT/US2012/032865

C(Continuation). DOCUMENTS CONSIDERED TO BE RELEVANT		
Category*	Citation of document, with indication, where appropriate, of the relevant passages	Relevant to claim No.
X	US 4 234 103 A (STROBL JR FREDERICK P ET AL) 18 November 1980 (1980-11-18) the whole document -----	1-6, 8-10,18
X	US 2003/099573 A1 (TSEUNG KEN K [US] ET AL) 29 May 2003 (2003-05-29) paragraph [0040]; figure 6 -----	1-6, 8-10,17, 18
X	US 7 553 455 B1 (RENZI RONALD F [US] ET AL) 30 June 2009 (2009-06-30) column 4, line 23 - column 7, line 51; figures 1-10 -----	1-19

INTERNATIONAL SEARCH REPORT

International application No.
PCT/US2012/032865

Box No. II Observations where certain claims were found unsearchable (Continuation of item 2 of first sheet)

This international search report has not been established in respect of certain claims under Article 17(2)(a) for the following reasons:

1. Claims Nos.:
because they relate to subject matter not required to be searched by this Authority, namely:

2. Claims Nos.:
because they relate to parts of the international application that do not comply with the prescribed requirements to such an extent that no meaningful international search can be carried out, specifically:

3. Claims Nos.:
because they are dependent claims and are not drafted in accordance with the second and third sentences of Rule 6.4(a).

Box No. III Observations where unity of invention is lacking (Continuation of item 3 of first sheet)

This International Searching Authority found multiple inventions in this international application, as follows:

see additional sheet

1. As all required additional search fees were timely paid by the applicant, this international search report covers all searchable claims.

2. As all searchable claims could be searched without effort justifying an additional fees, this Authority did not invite payment of additional fees.

3. As only some of the required additional search fees were timely paid by the applicant, this international search report covers only those claims for which fees were paid, specifically claims Nos.:

4. No required additional search fees were timely paid by the applicant. Consequently, this international search report is restricted to the invention first mentioned in the claims; it is covered by claims Nos.:

Remark on Protest

- The additional search fees were accompanied by the applicant's protest and, where applicable, the payment of a protest fee.
- The additional search fees were accompanied by the applicant's protest but the applicable protest fee was not paid within the time limit specified in the invitation.
- No protest accompanied the payment of additional search fees.

FURTHER INFORMATION CONTINUED FROM PCT/ISA/ 210

This International Searching Authority found multiple (groups of) inventions in this international application, as follows:

1. claims: 2-6, 8-10, 18(completely); 1, 17(partially)

A cap suitable for a reagent storage vessel comprising a partitioning element, a projection fitting, a holder element, a puncturing element, furthermore a sealing element, and the correlated materials and method of construction.

2. claims: 7, 11-16, 19(completely); 1, 17(partially)

A microfluidic device assembly, comprising a cap suitable for a reagent storage vessel comprising a partitioning element, a projection fitting, a holder element, a puncturing element, a sealing element, furthermore a microfluidic device and the correlated method of construction.

INTERNATIONAL SEARCH REPORT

Information on patent family members

International application No

PCT/US2012/032865

Patent document cited in search report	Publication date	Patent family member(s)	Publication date	
EP 1909089	A1	09-04-2008	AU 2006256359 A1	14-12-2006
			CN 101194154 A	04-06-2008
			EP 1909089 A1	09-04-2008
			JP 4811404 B2	09-11-2011
			US 2009269246 A1	29-10-2009
			WO 2006132041 A1	14-12-2006

US 2005014273	A1	20-01-2005	AT 479085 T	15-09-2010
			AU 2002325617 A1	10-03-2003
			EP 1421361 A2	26-05-2004
			US 2005014273 A1	20-01-2005
			US 2009068674 A1	12-03-2009
			US 2011212517 A1	01-09-2011
			WO 03019131 A2	06-03-2003

EP 1995182	A1	26-11-2008	AT 540875 T	15-01-2012
			CA 2679654 A1	04-12-2008
			CN 101678931 A	24-03-2010
			EP 1995182 A1	26-11-2008
			EP 2148823 A1	03-02-2010
			JP 2010527852 A	19-08-2010
			US 2010113976 A1	06-05-2010
WO 2008145294 A1	04-12-2008			

US 4234103	A	18-11-1980	AU 527380 B2	03-03-1983
			AU 4492679 A	04-10-1979
			CA 1093512 A1	13-01-1981
			GB 2017661 A	10-10-1979
			GB 2100237 A	22-12-1982
			US 4234103 A	18-11-1980

US 2003099573	A1	29-05-2003	US 2003099573 A1	29-05-2003
			US 2006127283 A1	15-06-2006
			US 2009042243 A1	12-02-2009
			US 2010093079 A1	15-04-2010
			US 2011176977 A1	21-07-2011
			US 2012219469 A1	30-08-2012

US 7553455	B1	30-06-2009	US 7553455 B1	30-06-2009
			US 8163254 B1	24-04-2012
