

(No Model.)

E. I. BLOUNT.  
DOOR CHECK OR CLOSER.

No. 527,585.

Patented Oct. 16, 1894.

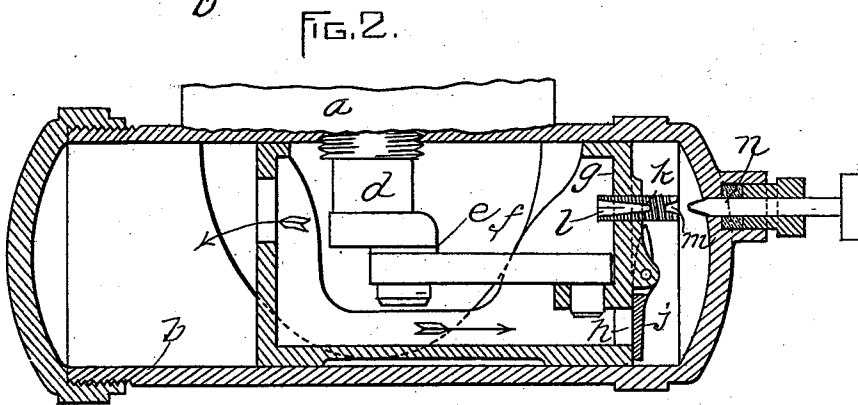
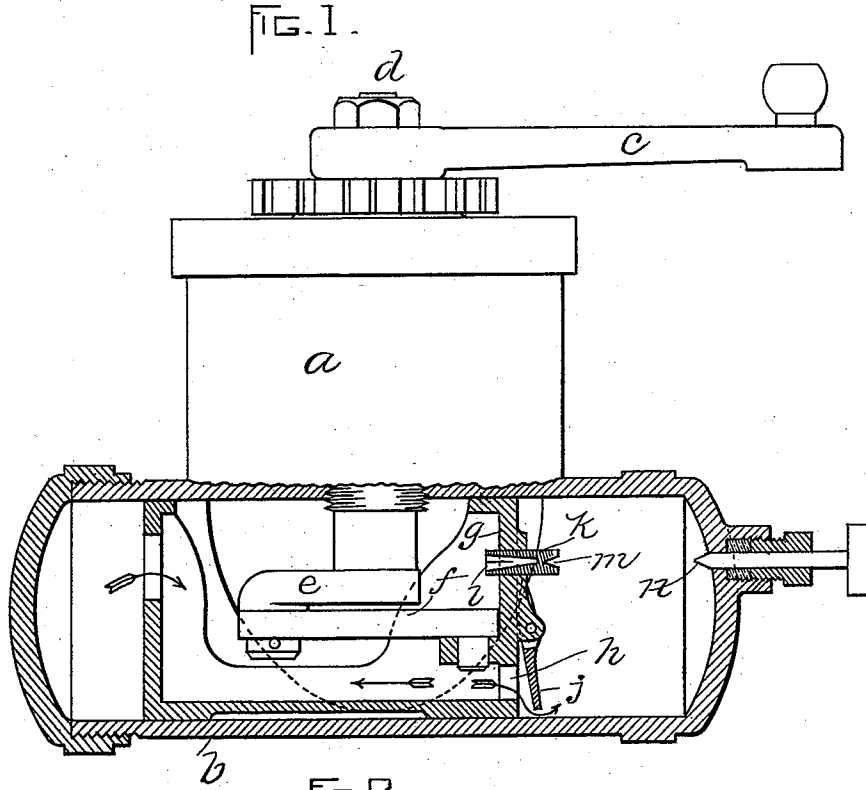

FIG. 5.

WITNESSES:

A. S. Harrison  
W. F. M. Lee

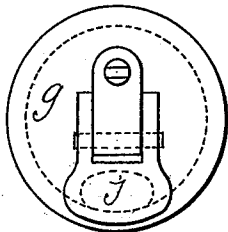

FIG. 6.

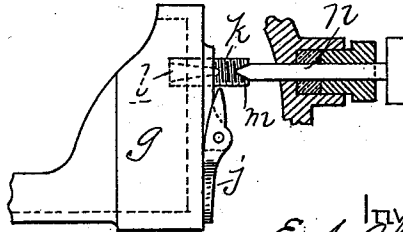

FIG. 7.

INVENTOR:  
E. I. Blount,  
Wright, Brown & Crossley,  
Attys.

# UNITED STATES PATENT OFFICE.

EUGENE I. BLOUNT, OF GARDNER, MASSACHUSETTS, ASSIGNOR TO THE  
BLOUNT MANUFACTURING COMPANY, OF PORTLAND, MAINE.

## DOOR CHECK OR CLOSER.

SPECIFICATION forming part of Letters Patent No. 527,585, dated October 16, 1894.

Application filed December 27, 1893. Serial No. 494,868. (No model.)

### *To all whom it may concern:*

Be it known that I, EUGENE I. BLOUNT, of Gardner, in the county of Worcester and State of Massachusetts, have invented certain new and useful Improvements in Door Checks or Closers, of which the following is a specification.

This invention has relation to means for regulating valves in reciprocating pistons, so as to govern the extent of the flow of fluid through the port or ports in connection with which the valve operates.

As herein shown and described the improvement is illustrated in connection with a liquid door check and closer, though it will be apparent to those skilled in the art that it may be employed in connection with other reciprocating pistons as well.

It is the object of my invention to provide such improvements as will enable the user of a liquid door check, or other person, to regulate the valve controlling a port in the piston so as to vary the extent of flow of fluid through such port, by means outside of the device without the necessity of taking it apart or gaining direct access to the piston.

To these ends the invention consists in providing the piston with an adjustable valve, and equipping the casing with movable means extending to the outside, whereby the valve may be engaged and adjusted, all as I will now proceed to describe in detail and point out in the appended claim.

Reference is to be had to the annexed drawings and to the letters marked thereon, forming a part of this specification, the same letters designating the same parts or features, as the case may be, wherever they occur.

Of the drawings—Figure 1 is a front elevation of a liquid door check and closer equipped with my improvement, the liquid cylinder and parts operating in connection therewith being shown in longitudinal vertical section. In this view the piston is represented as being drawn back and at or near the extremity of its rearward movement. Fig. 2 is a view similar to Fig. 1 showing the piston as at or near the limit of its forward movement. Fig. 3 is an end elevation of the piston. Fig. 4 is a detail sectional view showing the manner of engaging the adjustable

valve in the piston by means of the external means. Fig. 5 is a sectional detail view of the form of valve selected for explanation of the invention.

In the drawings—*a* designates the casing of the spring chamber; *b*, the casing of the liquid chamber; *c*, the arm connecting the operative parts with the door; *d*, the spindle with which the spring (not shown) is connected, and which extends into the liquid chamber where it is provided with a crank *e* and pitman *f*, or other suitable means for reciprocating the piston *g*.

In liquid door-checks of this kind it is usual to provide means whereby when the door is opened the liquid may flow from the rear to the front of the piston with freedom and without offering considerable resistance to the movement of the door, but when the latter is closing to resist its movement to a degree to prevent slamming by allowing the liquid to flow only through a restricted port or passage-way. As the condition of the liquid changes with changes in the temperature of the weather and from other causes, it is necessary sometimes to adjust the valve controlling the restricted port or passage-way. As it is desirable under some circumstances and for some purposes to have the said port and valve in the piston, and that the device should not to any extent be taken apart to adjust the valve, I have, by my invention, provided means whereby the said adjustment may be effected by external means.

In the present instance both the free and the restricted valve are formed in the piston, though the former may be made as a valve-controlled passage-way connecting the ends of the portion of the liquid cylinder or chamber in which the piston operates, as is now sometimes done.

*h* designates the free or larger port formed in the piston *g'* which port is controlled by an ordinary clapper valve *j*, shown as open in Fig. 1 and as closed in Figs. 2, 3 and 4.

*k* is the valve for controlling the restricted port and in which valve, in the present case, the port is formed. The valve *k* is constructed as a screw-valve, and is fluted or grooved in its sides as at *l* to form ports for the passage of the liquid, though other suit-

able constructions may be provided with which a screw-valve is adapted to co-operate. A kerf or slot *m* is formed in the outer end of the screw-valve, and a pin or plunger *n* having a sharpened inner end to engage the said kerf or slot is arranged in packed bearings in the casing, so that it may be thrust in to engage the screw-valve, as shown in Fig. 4, and turned to adjust said valve, as may be desired, and then drawn back, as shown in Figs. 1 and 2, so as to be out of the way of the piston. Any suitable means may be provided whereby the pin or plunger *n* cannot be wholly withdrawn or forced out.

By the means described I am enabled in a very simple manner to provide entirely efficient means for adjusting the valve in the piston without taking the device apart, and with certainty and entire readiness.

Having thus explained the nature of the invention and described a way of constructing and using the same, though without attempting to set forth all of the forms in which it may

be made or all of the modes of its use, it is declared that what is claimed is—

A door-check and closer comprising in its construction a reciprocating piston, an independent adjustable slotted screw valve in the piston, an independent rotary and longitudinally movable pin or rod supported in the head of the casing and packed to prevent leakage, said pin or rod having a sharpened end for engaging the slot of the screw-valve in order to adjust the same, the construction and arrangement being such that the pin may be moved entirely out of the way and out of engagement with the piston when not needed for use.

In testimony whereof I have signed my name to this specification, in the presence of two subscribing witnesses, this 20th day of December, A. D. 1893.

EUGENE I. BLOUNT.

Witnesses:

ARTHUR W. CROSSLEY,  
A. D. HARRISON.