

(19) World Intellectual Property Organization
International Bureau



(43) International Publication Date
17 April 2008 (17.04.2008)

PCT

(10) International Publication Number
WO 2008/043178 A1

(51) International Patent Classification:

E04H 12/22 (2006.01) *E02D 5/80* (2006.01)
B23P 15/00 (2006.01) *E04H 17/22* (2006.01)
E02D 5/74 (2006.01)

(21) International Application Number:

PCT/CA2007/001813

(22) International Filing Date: 11 October 2007 (11.10.2007)

(25) Filing Language: English

(26) Publication Language: English

(30) Priority Data:

2,563,135 11 October 2006 (11.10.2006) CA
2,573,995 16 January 2007 (16.01.2007) CA

(71) Applicant (for all designated States except US): **PEAK INNOVATIONS INC.** [CA/CA]; Attn: IP Legal Dept., 203 - 11782 Hammersmith Way, Richmond, British Columbia V7A 5E2 (CA).

(72) Inventors; and

(75) Inventors/Applicants (for US only): **WALKER, Simon** [CA/CA]; 203 - 11782 Hammersmith Way, Richmond, British Columbia V7A 5E2 (CA). **HOPKINSON, Mark** [CA/CA]; 203 - 11782 Hammersmith Way, Richmond, British Columbia V7A 5E2 (CA). **ZHU, Jianzhong** [CN/CN]; 203 - 11782 Hammersmith Way, Richmond, British Columbia V7A 5E2 (CA).

(74) Agent: **HOPKINSON, Mark**; Peak Innovations Inc., c/o IP Legal Dept., 203 - 11782 Hammersmith Way, Richmond, British Columbia V7A 5E2 (CA).

(81) Designated States (unless otherwise indicated, for every kind of national protection available): AE, AG, AL, AM, AT, AU, AZ, BA, BB, BG, BH, BR, BW, BY, BZ, CA, CH, CN, CO, CR, CU, CZ, DE, DK, DM, DO, DZ, EC, EE, EG, ES, FI, GB, GD, GE, GH, GM, GT, HN, HR, HU, ID, IL, IN, IS, JP, KE, KG, KM, KN, KP, KR, KZ, LA, LC, LK, LR, LS, LT, LU, LY, MA, MD, ME, MG, MK, MN, MW, MX, MY, MZ, NA, NG, NI, NO, NZ, OM, PG, PH, PL, PT, RO, RS, RU, SC, SD, SE, SG, SK, SL, SM, SV, SY,

[Continued on next page]

(54) Title: GROUND SPIKE

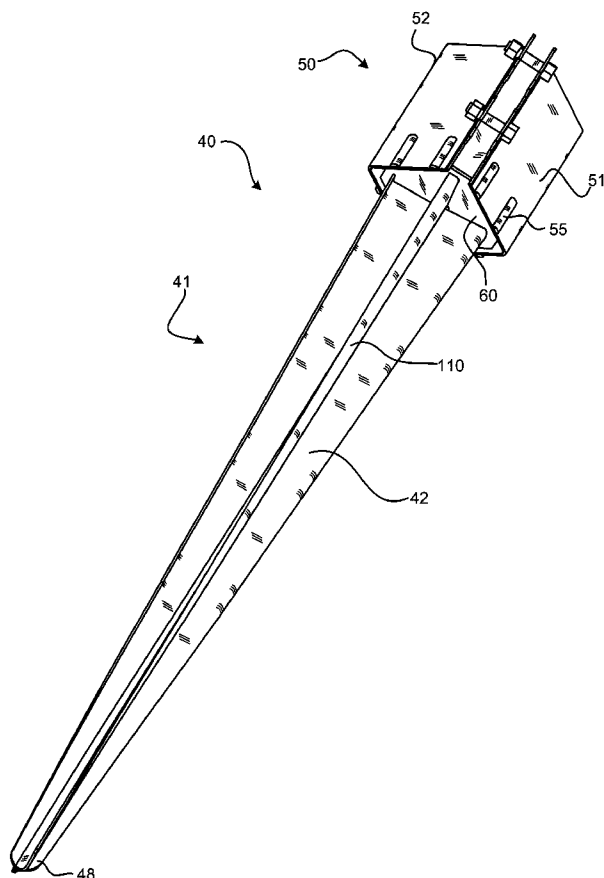

(57) Abstract: A ground spike is disclosed having a plurality of blades and a flat plate secured thereto. The blades each have a reinforcement deformation proximal to a longitudinal outer edge. The reinforcement deformation may be a reinforcement line stamped therein, may be a bent outer edge, or the like. Objects may be attached to the flat plate, thereby securing such objects to the ground when the ground spike is used. The ground spike may have a post receiving socket secured to the flat plate. Each component may comprise metals of varying thickness and rigidity or other suitable materials.

WO 2008/043178 A1



TJ, TM, TN, TR, TT, TZ, UA, UG, US, UZ, VC, VN, ZA, ZM, ZW.

FR, GB, GR, HU, IE, IS, IT, LT, LU, LV, MC, MT, NL, PL, PT, RO, SE, SI, SK, TR), OAPI (BF, BJ, CF, CG, CI, CM, GA, GN, GQ, GW, ML, MR, NE, SN, TD, TG).

(84) Designated States (*unless otherwise indicated, for every kind of regional protection available*): ARIPO (BW, GH, GM, KE, LS, MW, MZ, NA, SD, SL, SZ, TZ, UG, ZM, ZW), Eurasian (AM, AZ, BY, KG, KZ, MD, RU, TJ, TM), European (AT, BE, BG, CH, CY, CZ, DE, DK, EE, ES, FI,

Published:

- *with international search report*
- *with amended claims*

GROUND SPIKE

Field Of The Invention

5

This invention relates to supporting and firmly anchoring vertical posts, such as fence posts and the like, in the ground.

Reference to Earlier Filed Application

10

This application claims priority from Canadian patent application No. 2,563,135 filed October 11, 2006 and Canadian patent application No. 2,573,995 filed January 16, 2007.

Background Of The Invention

15

It is desirable to be able to securely fasten various objects to the ground. One object that is commonly secured to the ground is a vertical post.

20 When installing a vertical post, such as a fence post, it is common to support the post in the ground by one of: (1) burying one end of the post in a hole dug in the ground; (2) filling the area around the base of the post with concrete; or (3) securing the post to a ground spike that, in turn, is secured into the ground.

25

Burying one end of the post in the ground is often unsatisfactory for various reasons, including that digging out a suitable hole and burying the post may be difficult and the ground may not provide suitable support. This may result in a wobbly post that is not well suited for anchoring a fence or the like. A
30 buried post may also be susceptible to rot.

Filling the area around the base of the post with concrete has its own limitations. This requires digging suitable holes around each post, acquiring

sufficient concrete to set each post, mixing concrete, pouring concrete into holes around each post, and ensuring that the post is held straight while the concrete sets.

- 5 Securing posts to post support means, such as metal ground spikes, is a relatively easy and cost efficient alternative for securing a post to the ground.

10 Metal ground spike post supports of varying shapes have been used to secure posts to the ground. U.S. Patent No. 4,271,646 to Mills discloses a prior art metal post support (2) having a ground engaging blade portion (4) and a post supporting hollow box portion (6) as shown in Figures 1 and 2. Mills discloses four blades (8) disposed in a cross-shaped cross-section, meeting at a central joint (10). Each of the four blades (8) is welded to a flat plate (16), which in turn is welded onto the sides (12) of the hollow box portion
15 (6). The Mills post support is made of mild steel plate of one-eighth inch thickness (3.2 mm). To allow drainage of water entering the box-section (14), drain holes may be drilled in the plate (16). To secure a post to the Mills post support, holes may drilled in the sides (12), through which bolts can be inserted.

20

A second common ground spike post support (20) is illustrated in Figure 3. The common ground spike (20) has a blade portion (21) comprising four blades (22), and a post socket portion (30). The blade portion may be made by cutting two pieces of metal, then bending the two halves of each piece of the metal into a perpendicular arrangement along a longitudinal fold line (23
25 or 24). The two pieces of metal are then attached along the respective fold lines by a welded connection (25).

30 The post socket portion (30) is made from a unitary piece of metal. Three perpendicular bends (along bend lines 32) form four walls (31) to the post socket (30). Perpendicular bends (along bend lines 34) enable base tabs (35) to form a partially closed lower surface of the post socket (30). Clamping tabs

(36) are formed in one corner of the post socket (30) by additional bends (along lines 33) in the metal. Apertures (38) for bolt connectors appear in the clamping tabs (36).

- 5 The blade portion (21) is attached to the post socket portion (30) by a welded connection (28) between the top of each blade (22) and the lower face of the base tabs (35).

10 The blade portion (21) and post socket portion (30) of the common ground spike (20) are typically made of the same metal material, often having a thickness of between 2.5 mm and 3.5 mm. Mills discloses use of steel having a thickness of one-eighth inch (3.2 mm). The cost of the metal starting material is a major component of the cost of producing a ground spike. Reducing the thickness of metal for the prior art ground spike designs result in
15 premature deformations and failures under normal to heavy wear conditions.

There exists a need for stronger, improved blades for a ground spike post support. There exists a need for a stronger, improved ground spike design, preferably that requires less metal such that it can be manufactured for a
20 lower cost without sacrificing product quality.

Brief Description Of The Drawings

25 The invention will be described with reference to the detailed description of the invention and to the drawings thereof in which:

Fig. 1 is a perspective view of a first prior art ground spike post support;

30 Fig. 2 is a bottom plan view of the first prior art ground spike post support;

Fig. 3 is a perspective view of a second prior art ground spike post support;

Fig. 4 is a perspective view of an embodiment of the invention;

5

Fig. 5 is a perspective view of an embodiment of the invention;

Fig. 6 is an exploded perspective view of an embodiment of the invention;

10

Fig. 7 is a perspective view of an embodiment of the invention;

Fig. 8 is a top plan view of an embodiment of the invention;

15

Fig. 9 is a bottom plan view of an embodiment of the invention;

Fig. 10 is a top plan view of an embodiment of the invention;

Fig. 11 is a bottom plan view of an embodiment of the invention;

20

Fig. 12 is a perspective view of a portion of blade material according to an embodiment of the invention;

Fig. 13 is a cross-sectional top plan view of a blade portion according to an embodiment of the invention;

25

Fig. 14 is a plan view of starting material used in the construction of a blade portion of an embodiment of the invention;

30

Fig. 15 is a plan view of starting material used in the construction of a base plate of an embodiment of the invention;

Fig. 16 is a plan view of starting material used in the construction of a socket portion of an embodiment of the invention;

5 Fig. 17 is a plan view of starting material used in the construction of a blade portion of an embodiment of the invention;

Fig. 18 is a plan view of starting material used in the construction of a socket portion of an embodiment of the invention;

10 Fig. 19 is a plan view of starting material used in the construction of a base plate of an embodiment of the invention;

Fig. 20 is an enlarged partial perspective view of the socket portion of an embodiment of the invention;

15 Fig. 21 is a partial perspective view of the socket portion of an embodiment of the invention;

20 Fig. 22 is a partial perspective view of the socket portion of an embodiment of the invention;

Fig. 23 is a partial perspective view of the socket portion of an embodiment of the invention;

25 Fig. 24 is a partial perspective view of the socket portion of an embodiment of the invention;

Fig. 25 is a bottom view of an embodiment of the invention;

30 Fig. 26 is a bottom view of an embodiment of the invention;

Fig. 27 is a bottom view of an embodiment of the invention;

Fig. 28 is a bottom view of an embodiment of the invention;

Fig. 29 is a side view of an embodiment of the invention;

5

Fig. 30 is a top view of an embodiment of the invention;

Fig. 31 is a top view of an embodiment of the invention;

10

Fig. 32 is a side view of an embodiment of the invention;

Fig. 33 is a bottom view of an embodiment of the invention;

Fig. 34 is a top view of an embodiment of the invention;

15

Fig. 35 is a perspective view of an embodiment of the invention;

Fig. 36 is a bottom view of an embodiment of the invention;

20

Fig. 37 is a bottom view of an embodiment of the invention;

Fig. 38 is a bottom view of an embodiment of the invention;

Fig. 39 is a bottom view of an embodiment of the invention;

25

Fig. 40 is a bottom view of an embodiment of the invention;

Fig. 41 is a bottom view of an embodiment of the invention;

30

Fig. 42 is a bottom view of an embodiment of the invention;

Fig. 43 is a bottom view of an embodiment of the invention;

Fig. 44 is a bottom perspective view of an embodiment of the invention;

Fig. 45 is a top perspective view of an embodiment of the invention;

5

Fig. 46 is a bottom perspective view of an embodiment of the invention;

Fig. 47 is an perspective view of an embodiment of the invention;

10

Fig. 48 is a perspective view of an embodiment of the invention;

Fig. 49 is a perspective view of an embodiment of the invention.

Detailed Description Of The Invention

15

Throughout the following description specific details are set out to provide a more thorough understanding of the invention. However, the invention may be practiced without these particulars. In other instances, well known elements have not been shown or described in detail to avoid unnecessarily obscuring the present invention. Accordingly, the description and drawings are to be regarded in an illustrative, rather than a restrictive, sense.

20

25

With reference to Figure 4 and subsequent figures, embodiment **200** comprises a ground engaging blade portion **41** and a base plate **60**.

The blade portion **41** comprises a plurality of blades **42** designed for driving into the ground. In embodiment **40**, there are four blades **42**, though alternate embodiments may have two, three, five, six or more blades. The blades have a reinforcement deformation proximal to a longitudinal outer edge thereof. In embodiment **200** the reinforcement deformation comprises a bent outer edge **110**. In certain other embodiments, such as embodiments **40'**, **104** and **106**, reinforcement deformations are illustrated as reinforcement lines that have

30

been stamped or otherwise marked as lines **46**, **47** into the blades. Each reinforcement line has a convex portion **46** on one side of the blade and a corresponding concave portion **47** on the other side of the blade.

5 Where the reinforcement deformation comprises a bent outer edge **110**, the blade may be bent proximal to a longitudinal outer edge thereof. At the top end of the blade, the distance **111** from the edge of the blade and the bend line may be any suitable distance. To minimize material the need for extra material, a distance between 2.5 mm and 10 mm may be suitable, and a
10 distance of approximately 5 mm may be preferable. In many embodiments the blades taper from the top end of the blade down to the tip **48**. This may make folding the blade difficult near the tip. The fold line may taper closer to the edge of the blade closer to the blade tip **48**. The bent outer edge **110** may be not run the entire length of the blade, but rather stop at point **201** short of
15 the tip of the blade by as much as 5% to 35% as shown in Figure 4. In embodiment **200**, the bent outer edge **110** terminates about 10% to 20% of the length **L** of the blade away from the tip **43** of the blade, and particularly about 15% away from the tip **43**.

20 The bend for the edge portion **110** may be any suitable angle **164**, such as 45 degrees to 120 degrees, or preferably between 80 degrees and 100 degrees, and most preferably approximately 90 degrees. Other angles less than 45 degrees or greater than 120 degrees may also be suitable for enhancing the strength of the blade to resist torsion forces when in use.

25

The blade portion **41** may be made from two pieces of metal, each having been cut, for example as shown in Figures 14, 17 or 6. Bending of the edges of the blades or stamping of reinforcement lines **46**, **47** on the blades **42** may occur before, after or contemporaneously with the cutting of the blade
30 material. The material is then bent at a substantially perpendicular angle along fold line **43** to form two blades **42A** and **42B**. This is repeated for a second piece of blade material which is folded to form two blades **42C** and

42D along fold line **44**. The two pieces of blade material may then be welded together along join **45**. Welding may be applied in 2, 3, 4 or more discrete portions of the join **45**, or it may be applied along the entire join.

- 5 The welds may comprise spot welds. In certain embodiments, regular welds are applied at the top and bottom of the join **45** and spot welds are applied in 1, 2, 3, 4, 5, or more positions along join **45**.

10 As shown in Figure 12, multiple holes **120** may be cut in the blade material along fold line **43** to facilitate the welding process. In this case regular welds can be applied in each hole. Figure 12 illustrates 4 holes, although 2, 3, 5 or more holes may also be provided in accordance with this invention.

15 To facilitate the welding process, discrete apertures may be cut along fold lines **43** and **44**. The discrete apertures can coincide with the portions to be welded so that the weld may be applied from a single side of the blades.

20 If the outer edges of the blades are bent due to the stamping of reinforcement lines, the edge of the blades may be straightened, such as by mechanical straightening. This can occur before or after the bending of the blade material.

25 In alternate embodiments, the blade portion may be constructed without folding by welding individual blade pieces together along join **45**.

30 Base plate **60** is preferably formed of a unitary piece of metal. The base plate **60** may comprise apertures **203** for securing means to the ground spike. Any item that is desired to be secured to the ground could be secured to the base plate. For example, a metal fence could be bolted to the base plate, possibly via a foot joint for securing the post to the plate **60**. Other items could also be secured to the base plate **60** such as floodlights, sprinkler systems, lawn ornaments, etc. The size of the base plate **60** can vary significantly

depending upon the desired use. Apertures **203** may also be of different shape, such as oblong if the ability to laterally position an object away from the centre of the ground spike is desired. The rotational positioning of the blades with respect to the base plate may also be varied as shown with
5 reference to figures 8-11 and embodiments **200** and **208**.

The base plate may be reinforced with reinforcement deformations. The reinforcement deformation may comprise a bent outer edge **206** or may comprise reinforcement lines **62**.
10

In certain embodiments, such as embodiment **40**, the base plate is secured to each of the sides of the socket portion **50**. As shown in Figures 15 and 19, socket base plate **60** has four main sides **65** that define a square in the approximate dimensions of the inside of the socket portion **50**. Each of the
15 four corners of the square may be cut out. Socket base plate **60** has three removed corners **66** of equal size, and a larger removed corner **68** to correspond with the corner in which the clamping tabs **56** are located in embodiment **40**. Socket base plate **60** may have a central aperture **64**. The central aperture **64** and the cut-out corners **66** may assist in the drainage of
20 water or liquids when in use, and may assist in powder coating or painting during manufacture. Bent edges **206** may assist with reinforcement of the plate **60**, particularly against torsion forces when the ground spike is in use.

Reinforcement lines **62** may be stamped into socket base plate **60** for
25 increased strength and rigidity, which may increase the resistance of the base plate **60** to torsion forces.

With reference to Figure 13, where the blade portion **41** has four blades, made from two pieces of metal, the angles **160** and **162** may be varied away
30 from 90 degrees. Where two blades are made out of a unitary piece of metal such as shown in figures 12 and 13, and where the two edges **110** are bent towards each other, arranging four blades at 90 degrees to each other would

result in uneven soil displacement/working areas. For example, where angles **160** and **162** are 90 degrees, the distance **166** that could exert pressure on surrounding ground would be less than the distance **168**, and will be much less than the distance **170**. Distance **166** forms the shortest footprint distance of the ground spike. Depending upon which direction external forces pressure the ground spike when it is bearing a load in the ground, it may be desirable to maximize the shortest footprint distance, such as by making distance **166** approximately equivalent to distance **168**. This can be done by varying the angles **160** and **162** as necessary. For example, an angle of about 95 degrees for **160** and a resulting angle of about 85 degrees for **162** may result in distance **166** approximately equaling distance **168**.

Embodiment **40** further comprises a post receiving socket portion **50**. The post supporting socket portion **50** comprises four side walls **51** that are in a substantially perpendicular arrangement to each other. Reinforcement lines **55** may be stamped or otherwise marked in each side wall **51**. The reinforcement lines **55** may be concentrated on the lower portion of the socket portion **50**, or may extend further up the side walls **51**. One, two, three, or more reinforcement lines **55** may be applied to each side wall **51**.

Clamping tabs **56** may be provided on one or more corners of the socket portion **50**. The clamping tabs may take one of various forms known in the art. Examples of differently shaped clamping mechanisms can be seen with reference to embodiments **80**, **82**, and **84**. Clamping tabs have apertures **58** to allow a bolt to pass therethrough for tightening the socket portion **50** on a post placed therein during installation. Clamping tabs may have one, two, three, or more apertures **58** to allow various numbers of bolts to secure the socket portion **50** to a post.

Once the blade portion **41**, the socket portion **50**, and the socket base plate **60** have been manufactured as described above, embodiment **40** is further assembled by welding each of the four sides **65** of the socket base plate to a

- 12 -

side wall **51** of the socket portion **50**. For example, side **65A** may be welded to side wall **51A**, and side **65B** may be welded to side wall **51B**, etc. The length of the weld between each side **65** and side wall **51** is almost the entire depth **D** of each side wall **51**.

5

The length **L** of the blades may be any suitable length, for example between 40 and 10 inches, or more preferably between 32 and 24 inches. The length of the blades portion **41** may be varied according to the soil conditions of the application.

10

The width **W** of the blades may be any suitable length for a given application. Where the application is for supporting a 4x4 post, which is generally 3.5" by 3.5" wide, the inside depth **D** of each side wall **51** of the socket portion **50** may be slightly more than 3.5". In this case the width **W** will be the same or less than the distance between opposing sides **65** of the square **61** defined by plate **60** if the blades **42** are welded to the plate **60** at angles parallel to the sides **65**. In embodiments where the blades **42** are parallel to the sides **65**, width **W** will be between 3.5" and 2.5", and more preferably between 3.5" and 3", and most preferably between 3.5" and 3.3". In embodiments where the blades **42** are welded to the plate **60** at approximately 45 degree angles to the sides **65** (i.e. the top surface of the blades extend towards the corners of square **61**), then width **W** must be the same or less than the length of a diagonal line that would extend from corner to opposite corner of the square **61**. For supporting a 4x4 post that is 3.5" by 3.5" wide, the diagonal line **69** extending between opposite corners of square **61** may be about 5". For embodiments with blades welded to plate **60** generally along diagonal line **69**, the width **W** will be between 5" and 2.5", preferably between 5" and 4" and more preferably between 4.9" and 4.5".

30

The blades taper from the top to the bottom, such that the width **T** at the tip of the blades is significantly less than the width **W** at the top of the blade portion.

It is noted that the width **W**, which is illustrated as being the width of the piece of material that is bent to form blades **42A** and **42B**, is approximately the same as the width of the top portion of the assembled blade portion **41**. Similarly the width **T** is generally the same as the width of the tip portion **48** of the assembled blade portion **41**. Although in practice these widths may vary, particularly due to variations in the curvature of bends **43** and **44** and in the welds joint **45**, for ease of reference in this section widths **W** and **T** are treated as equivalent and therefore reference to one of these widths may be applied to either width value.

5

Height **H** of the socket portion **50** may be any suitable height. If height **H** is too high, the post support will not be suitable for constructing certain fences because dogs, raccoons or other animals may fit under the fence. For 4x4 post installations, height **H** may be between 6.5" to 4" or more preferably between 4.75" and 5.75", and most preferably between 5" and 5.5".

10

Alternate embodiments of the blade portion **41'**, the socket portion **50'** and the plate **60'** are within the scope of the invention. Blade portion **41'** has cut outs **49** which protrude from one side of the blade. Other alterations to the surface of the blades, including stamped out portions or alternative reinforcement mechanisms are understood to fall within the scope of the invention. The blade tip **48** may be of any suitable shape, including having a rounded end, having tips cut off, or with the tips square (not shown).

15

Plate **60'** has tabs **74** that may be folded perpendicular to the flat surface **70** along lines **72**. Plate **60'** may be welded to the side walls **51** of the socket portion **50** along one or both of the fold line **72** and the outer edge of tab **74**.

20

Socket portion **50'** shows alternate embodiments for clamping tabs **56'** in which the entire tab, that may have two apertures **58**, remains as a single piece of material. The corners **59** of the clamping tabs **56'** may or may not be

25

30

removed. Rounded corners may increase the safety of handling the ground spike.

5 Figure 20 shows an enlarged perspective view of the underside of the socket portion **50** of embodiment **40**. Plate **60** is welded a distance **76** away from the lower edge of the side walls **51**. Distance **76** may be between 30 mm and 0 mm, preferably between 15 mm and 2 mm, and more preferably between 10 mm and 3 mm. One consideration in choosing a suitable distance **76** may be the distance that can be filled entirely with weld material.

10

Width **W** of the blade portion **41** may be varied to fit on plate **60**. The distance **78** between the closest top edge corner of the blade portion **41** and the side wall **51** (measured along a line that continues in the plane of the blade) may be between 0 mm and 40 mm, preferably between 0 mm and 25 mm, and
15 more preferably between 0 mm and 15 mm.

Although various clamping mechanisms have been described, embodiment **86** illustrates a post support with no clamping mechanism. The side walls can be welded together to form a join in place of the clamping mechanism.

20

Different orientations of the blades are within the scope of the invention. Embodiments **40** and **82** show an X-shaped design wherein the blades extend towards the corners of the socket. Embodiment **92** shows a +-shaped cross-section where the blades extend towards the mid sections of the walls **51**.
25 Embodiment **90** shows an orientation of the blades that is intermediate between the X-shape and the +-shape cross-sections. The distance **78** can be varied, such as from approximately 0 mm shown in embodiment **82** to between 5 and 25 mm shown in embodiment **40**.

30 Embodiment **40** has two reinforcement lines on the plate **60**, whereas embodiments **82**, **90** and **92** do not have reinforcement lines on the plate.

The corners and aperture **64** that may be cut from the plate **60** may allow drainage of powder during powder coating and may allow drainage of fluid after installation.

- 5 Embodiment **92** has the blade portion **41** oriented 90 degrees from the orientation shown in embodiment **40**.

Embodiments **94** and **140** are adjustable ground spikes, having two domes **96** and **97** sitting in place of the base plate **60**. A bolt **99** and nut **98** arrangement
10 allows adjustment of the orientation of the socket from the blades portion during installation. This may be advantageous during installation, particularly if the blades are not driven into the ground straight. The socket may have an opening **95** to allow access by a wrench or other device to adjust and tighten the head of the bolt during installation. Domes **96** and **97** may be any suitable
15 thickness, such as between 3.0 mm and 9.0 mm, and more preferably between 5.0 mm and 7.5 mm. The domes **96** and **97** may be stamped with reinforcement lines, whether concentric circles or lines that radiate outward. Reinforcement lines can be stamped in the blades and in the socket.

- 20 For embodiments **94** and **140**, base plate **60** is a domed surface, namely lower dome **97**. In alternate embodiments of adjustable ground spikes, the base plate **60** may be a flat surface with a circular shape configured so that an upper dome can slide thereupon to adjust the angle and position of the post-receiving socket.

25 Embodiment **100** is an example of a post support that could be set in concrete. This type of post support does not require a blade portion. However the socket **50** and the plate **60** could be constructed in the same manner.

30 Embodiment **102** is an example of a post support that can be bolted down to a surface, such as a concrete surface or a wooden deck. The socket may be

constructed as in embodiment **40**. The plate may extend outward beyond the socket walls.

5 Embodiments **104** and **106** are examples of post supports having plates **108** that extend outward beyond the socket walls. Embodiment **106** also shows an alternate pattern for the construction of the blade elements. Reinforcement lines can be placed in some or all of the blades, socket and plate **108** in embodiments **104** and **106**.

10 Post support ground spikes are installed by placing a short post segment into the post socket, then hammering the post segment, which in turn drives the post support into the ground. No digging or mixing concrete is involved.

15 Different portions of the ground spike may be made of different types of metal, whether that be different alloys, different coatings on the metal, different treatments of the metal, and/or different thicknesses of metal. Early test results of the invention indicate that the portion of the ground spike that requires the thickest and/or strongest material is the base plate **60**. Test results further indicate that the portion of the ground spike that requires the least strength and/or may permit the least thickness is the socket portion **50**,
20 with the blade portion **41** requiring an intermediate strength and/or thickness of metal.

25 Test results also indicate that the socket portion **50** requires the most strength at and near the weld to the base plate **60**. For this reason, the reinforcement lines **55** in embodiment **40** only appear at or near the area in which the side walls **51** are welded to the base plate **60**. The reinforcement lines **55** may be raised slightly above the area in which the base plate **60** is welded so that there is no gap in the weld between the plate **60** and the side walls **51**.

30

The top one to two thirds of the blade portion require the most rigidity and the most resistance to torsion. The tips of the blades **48** also must be relatively

strong to avoid distortion when hitting rocks or other hard items when driven into the ground.

5 It is possible to weld additional pieces onto the blades, below the reinforcement lines, to add extra rigidity to the blade portion. This may be particularly useful when trying to minimize the thickness of the blades and yet are unable to stamp suitable reinforcement lines in certain sections of the blades, or where certain portions of the blades require extra reinforcement.

10 In alternate embodiments, reinforcement lines may be added, where practicable, to any portion of the ground spike without departing from the invention. The nature and pattern of the reinforcement lines, as well as the thickness of the lines and the depths of the contours may be varied.

15 Typically ground spike post supports are used to support posts that are generally square in cross section, for example a 4x4 post (which has side dimensions in cross section of 3.5 inches). However it is also possible to attach a suitable post socket for supporting posts with non-square cross sections, such as a rectangular cross-section, a triangular cross-section, a
20 circular cross-section or an oval cross-section. Other examples of supportable posts include 2x2, 3x3 and 5x5 in the imperial system, and 9x9, 7x7 and 5x5 posts in the metric system (i.e. 9 cm x 9 cm). The dimensions of the socket of the ground spike would vary accordingly, for example may be 91 mm to hold a 9 cm x 9 cm post, 71 mm to hold a 7 cm x 7 cm post, or similar
25 suitable variations. The distance between the edge of the post and the edge of the post support socket may be varied to correspond with the type of fastening mechanism chosen for the socket. For example a socket without a clamping mechanism which merely has holes for placing one or two anchoring bolts through the post and socket might be a closer fit than a socket having
30 wedge grips.

Ground spikes without lumber supporting sockets can be used to secure outdoor lighting, such as flood lamps or garden lights, garden ornaments, and water sprinkler hoses and nozzles.

5 Although ground spikes according to this invention have been primarily described as being comprised of metal, it is within the scope of the invention that the ground spike may comprise other suitable material such as plastic. Accordingly, ground spikes according to this invention may be made from injection molding. In such cases references to welding would clearly not
10 apply. The ground spike may be made of a unitary piece of plastic, such as PVC, or may comprise more than one piece of plastic and attached together by adhesion methods known in the art.

It will be appreciated by those skilled in the art that although certain
15 embodiments have been described above in some detail, many modifications may be practiced without departing from the principles of the invention.

WHAT IS CLAIMED IS:

1. A ground spike, comprising:
 - a plurality of vertically oriented blades,
 - 5 the blades coupled together along a central vertical axis;
 - a plate coupled to the plurality of vertically oriented blades along a top surface of the blades;
 - each of said blades comprising a reinforcement deformation proximal to a longitudinal outer edge.
- 10 2. The ground spike of claim 1 wherein the ground spike comprises plastic.
3. The ground spike of claim 1 wherein the ground spike comprises metal.
- 15 4. The ground spike of claim 3 wherein the reinforcement deformation comprises a reinforcement line.
5. The ground spike of claim 3 wherein the reinforcement deformation comprises a bent outer edge.
- 20 6. The ground spike of claim 5 wherein the plurality of blades is 4 blades.
7. The ground spike of claim 6 wherein the outer edge is bent at an angle between 45 degrees and 120 degrees.
- 25 8. The ground spike of claim 7 wherein the outer edge is bent at an angle between 80 degrees and 100 degrees.
9. The ground spike of claim 8 wherein the outer edge is bent at an angle
30 between 85 degrees and 95 degrees.

10. The ground spike of claim 8 wherein the bent outer edge terminates at a notch at a distance between 5% and 30% of the length of the blade away from a tip of the blade.
- 5 11. The ground spike of claim 10 wherein the bent outer edge terminates at a notch at a distance between 10% and 20% of the length of the blade away from a tip of the blade.
- 10 12. The ground spike of claim 10 wherein the bent outer edge terminates at a notch at a distance approximately 15% of the length of the blade away from a tip of the blade.
13. The ground spike of claim 11 wherein the plate comprises a bent outer edge.
- 15 14. The ground spike of claim 13 wherein the plate is bent at an angle between 45 degrees and 120 degrees.
- 20 15. The ground spike of claim 14 wherein the plate is bent at an angle between 80 degrees and 100 degrees.
16. The ground spike of claim 15 wherein the plate is bent at an angle between 85 degrees and 95 degrees.
- 25 17. The ground spike of claim 5 wherein the plurality of blades is 3 blades.
18. The ground spike of claim 16 wherein further comprising a post-receiving socket welded to the plate.
- 30 19. The ground spike of claim 18 wherein the socket is welded to the plate along each of four substantially perpendicular socket walls.

20. The ground spike of claim 19 wherein a plurality of reinforcement lines are stamped on each socket wall.
- 5 21. The ground spike of claim 20 wherein the plate extends in a plane, and said substantially perpendicular socket walls extend normal to said plane.
- 10 22. The ground spike of claim 21 wherein the reinforcement lines are vertical reinforcement lines that extend normal to the plane of the plate.
23. The ground spike of claim 22 wherein the socket is of sufficient dimensions to hold a 4x4 post.
- 15 24. The ground spike of claim 22 wherein the socket further comprises a set of opposing clamping tabs having a first clamping aperture therethrough for receiving a tightening bolt.
- 20 25. The ground spike of claim 22 wherein the plate comprises a drainage aperture therethrough.
- 25 26. The ground spike of claim 25 wherein the drainage aperture in the plate is a central drainage aperture.
27. The ground spike of claim 26 wherein the plate further comprises apertures in each closed corner between perpendicular socket walls.
- 30 28. The ground spike of claim 22 wherein the four blades comprise two sets of material, each set of material folded to form two blades, the two sets welded together at a join.
28. The ground spike of claim 22 wherein said socket is welded to said plate at an elevated distance from the bottom edges of said socket.

29. The ground spike of claim 28 wherein said elevated distance is between 1 mm and 20 mm.
- 5 30. The ground spike of claim 29 wherein said elevated distance is between 2 mm and 10 mm.
31. The ground spike of claim 30 wherein said elevated distance is between 2.5 mm and 7 mm.
- 10 32. The ground spike of claim 29 wherein said socket, said blades and said plate each comprise steel having a thickness between 1.3 mm and 3.5 mm.
- 15 33. The ground spike of claim 32 wherein said socket, said blades and said plate each comprise steel of between 1.5 mm and 2.5 mm.
34. The ground spike of claim 33 wherein said socket and said blades each comprise steel of between 1.5 mm and 2.5 mm and said plate comprises steel of between 2.0 mm and 3.5 mm.
- 20 35. The ground spike of claim 33 wherein said socket and said blades portion are a different thickness of metal from said plate.
- 25 36. The ground spike of claim 32 wherein each of said socket, said blades portion, and said plate comprise different thicknesses of metal.
37. The ground spike of claim 32 wherein said socket and said blades portion each comprise steel of between 1.7 mm and 1.9 mm and said plate comprises steel of between 2.3 mm and 2.7 mm.
- 30

38. The ground spike of claim 37 wherein said socket and said blades each comprise steel of between 1.8 mm and said plate comprises steel of between 2.5 mm.
- 5 39. The ground spike of claim 38 wherein the plate comprises a plurality of reinforcement lines are stamped therein.
40. The ground spike of claim 36 wherein the four blades are oriented in an X cross-section, the blades having upper outer edges extending towards
10 corners of the substantially perpendicular socket walls.
41. The ground spike of claim 36 wherein the four blades are oriented in a + cross-section, the blades having upper outer edges extending towards the mid sections of said four substantially perpendicular socket walls.
15
42. The ground spike of claim 41 wherein the upper outer edges are welded to the corners of the substantially perpendicular socket walls.
43. The ground spike of claim 42 wherein the upper outer edges are welded
20 to the mid sections of the substantially perpendicular socket walls.
44. The ground spike of claim 21 wherein said plate extends beyond said four substantially perpendicular socket walls.
- 25 45. The ground spike of claim 16 wherein said plate is dome-shaped.
46. The ground spike of claim 45 further comprising
a dome pivotally connected to said plate;
a post-receiving socket socket portion welded to said dome.
- 30 47. A method of manufacturing a ground spike comprising:
cutting a first blade material;

stamping reinforcement deformations in said first blade material;
folding said first blade material along a first longitudinal fold line to
form two blades;

cutting a second blade material;

5 stamping reinforcement deformations in said first blade material;
 folding said second blade material along a second longitudinal fold
line to form two blades;

welding said first blade material to said second blade material along
said first and second longitudinal fold lines to form a blade portion;

10 cutting a plate material comprising four sides;
 welding said blade portion to said plate.

48. The method of claim 47 further comprising:

cutting a socket-shaped material;

15 stamping reinforcement lines in said socket-shaped material;
 folding said socket-shaped material to form four substantially
perpendicular socket walls;

cutting a plate material comprising four sides;

welding the four sides of the plate material to the four substantially
20 perpendicular socket walls of the socket-shaped material.

49. The method of claim 48 wherein cutting the socket-shaped material
comprises cutting opposing clamping tabs; further comprising:

cutting opposing fastener apertures in clamping tabs; and

25 folding said socket-shaped material to form said two opposing
clamping tabs.

50. The method of claim 49 further comprising stamping reinforcement
deformations in said plate material.

30

51. The method of claim 50 wherein said reinforcement deformations comprise folding outer edges at an angle between 80 degrees and 120 degrees.
- 5 52. The method of claim 50 wherein said reinforcement deformations comprise stamping reinforcement lines.
53. The method of claim 49 further comprising cutting the corners off said plate.
- 10 54. The method of claim 49 wherein said socket-shaped material is cut from a first thickness of metal; said plate material is cut from a second thickness of metal; and said first and second blade materials are cut from a third thickness of metal; wherein said first, second and third thicknesses are between 1.5 mm and 4.0 mm.
- 15 55. The method of claim 54 wherein said second thickness of metal is thicker than said first and third thicknesses of metal.
- 20 56. The method of claim 55 wherein said third thickness of metal is thicker than said first thicknesses of metal.
57. The method of claim 54 wherein said first thickness of metal is between 1.5 mm and 2.5 mm; said second thickness of metal is between 2.0 mm and 4.0 mm; and said third thickness of metal is between 1.5 mm and 2.5 mm.
- 25 58. The method of claim 54 wherein said first thickness of metal is between 1.7 mm and 1.9 mm; said second thickness of metal is between 2.4 mm and 3.0 mm; and said third thickness of metal is between 1.7 mm and 1.9 mm.
- 30

59. The method of claim 57 wherein said cutting the socket-shaped material and said stamping of reinforcement lines in said socket-shaped material occur contemporaneously by using a progressive die.
- 5 60. The method of claim 57 further comprising powder coating the ground spike.
61. A method of installing the ground spike of claim 1 comprising
placing a target object on the plate;
10 hammering the target object downward until the plate rests at the desired level relative to the ground;
securing an object to the plate.
62. The method of claim 61 wherein placing a target object on the plate
15 comprises placing a target object in a post receiving socket, and wherein securing an object to the plate comprises securing a post to a post receiving socket.
63. The method of claim 62 wherein hammering the target object downward
20 comprises hammering with a sledge hammer or mallet.

AMENDED CLAIMS

received by the International Bureau on 28 March 2008 (28.03.2008)

1. A ground spike, comprising:
 - a plurality of vertically oriented blades,
 - the blades coupled together along a central vertical axis;
 - a plate coupled to the plurality of vertically oriented blades along a top surface of the blades;
 - each of said blades comprising a reinforcement deformation proximal to a longitudinal outer edge of said blades.
2. The ground spike of claim 1 wherein the ground spike comprises plastic.
3. The ground spike of claim 1 wherein the ground spike comprises metal.
4. The ground spike of claim 3 wherein the reinforcement deformation comprises a reinforcement line.
5. The ground spike of claim 3 wherein the reinforcement deformation comprises a bent outer edge of said blades.
6. The ground spike of claim 5 wherein the plurality of blades is 4 blades.
7. The ground spike of claim 6 wherein the outer edge is bent at an angle between 45 degrees and 120 degrees.
8. The ground spike of claim 7 wherein the outer edge is bent at an angle between 80 degrees and 100 degrees.
9. The ground spike of claim 8 wherein the outer edge is bent at an angle between 85 degrees and 95 degrees.

10. The ground spike of claim 8 wherein the bent outer edge terminates at a notch at a distance between 5% and 30% of the length of the blade away from a tip of the blade.
11. The ground spike of claim 10 wherein the bent outer edge terminates at a notch at a distance between 10% and 20% of the length of the blade away from a tip of the blade.
12. The ground spike of claim 10 wherein the bent outer edge terminates at a notch at a distance approximately 15% of the length of the blade away from a tip of the blade.
13. The ground spike of claim 11 wherein the plate comprises a bent outer edge of said plate.
14. The ground spike of claim 13 wherein the bent outer edge of said plate is bent at an angle between 45 degrees and 120 degrees.
15. The ground spike of claim 14 wherein the bent outer edge of said plate is bent at an angle between 80 degrees and 100 degrees.
16. The ground spike of claim 15 wherein the bent outer edge of said plate is bent at an angle between 85 degrees and 95 degrees.
17. The ground spike of claim 5 wherein the plurality of blades is 3 blades.
18. The ground spike of claim 16 further comprising a post-receiving socket welded to the plate.
19. The ground spike of claim 18 wherein the socket is welded to the plate along each of four substantially perpendicular socket walls.

20. The ground spike of claim 19 wherein a plurality of reinforcement lines are stamped on each socket wall.
21. The ground spike of claim 20 wherein the plate extends in a plane, and said substantially perpendicular socket walls extend normal to said plane.
22. The ground spike of claim 21 wherein the reinforcement lines are vertical reinforcement lines that extend normal to the plane of the plate.
23. The ground spike of claim 22 wherein the socket is of sufficient dimensions to hold a 4x4 post.
24. The ground spike of claim 22 wherein the socket further comprises a set of opposing clamping tabs having a first clamping aperture therethrough for receiving a tightening bolt.
25. The ground spike of claim 22 wherein the plate comprises a drainage aperture therethrough.
26. The ground spike of claim 25 wherein the drainage aperture in the plate is a central drainage aperture.
27. The ground spike of claim 26 wherein the plate further comprises apertures in each closed corner between perpendicular socket walls.
28. The ground spike of claim 22 wherein the four blades comprise two sets of material, each set of material folded to form two blades, the two sets welded together at a join.
29. The ground spike of claim 22 wherein said socket is welded to said plate at an elevated distance from the bottom edges of said socket.

30. The ground spike of claim 29 wherein said elevated distance is between 1 mm and 20 mm.
31. The ground spike of claim 30 wherein said elevated distance is between 2 mm and 10 mm.
32. The ground spike of claim 31 wherein said elevated distance is between 2.5 mm and 7 mm.
33. The ground spike of claim 30 wherein said socket, said blades and said plate each comprise steel having a thickness between 1.3 mm and 3.5 mm.
34. The ground spike of claim 33 wherein said socket, said blades and said plate each comprise steel of between 1.5 mm and 2.5 mm.
35. The ground spike of claim 34 wherein said socket and said blades each comprise steel of between 1.5 mm and 2.5 mm and said plate comprises steel of between 2.0 mm and 3.5 mm.
36. The ground spike of claim 34 wherein said socket and said blades portion are a different thickness of metal from said plate.
37. The ground spike of claim 33 wherein each of said socket, said blades portion, and said plate comprise different thicknesses of metal.
38. The ground spike of claim 33 wherein said socket and said blades portion each comprise steel of between 1.7 mm and 1.9 mm and said plate comprises steel of between 2.3 mm and 2.7 mm.

39. The ground spike of claim 38 wherein said socket and said blades each comprise steel of between 1.8 mm and said plate comprises steel of between 2.5 mm.
40. The ground spike of claim 39 wherein the plate comprises a plurality of reinforcement lines stamped therein.
41. The ground spike of claim 37 wherein the four blades are oriented in an X cross-section, the blades having upper outer edges extending towards corners of the substantially perpendicular socket walls.
42. The ground spike of claim 37 wherein the four blades are oriented in a + cross-section, the blades having upper outer edges extending towards the mid sections of said four substantially perpendicular socket walls.
43. The ground spike of claim 42 wherein the upper outer edges are welded to the corners of the substantially perpendicular socket walls.
44. The ground spike of claim 43 wherein the upper outer edges are welded to the mid sections of the substantially perpendicular socket walls.
45. The ground spike of claim 21 wherein said plate extends beyond said four substantially perpendicular socket walls.
46. The ground spike of claim 1 wherein said plate is dome-shaped.
47. The ground spike of claim 46 further comprising
 - a dome pivotally connected to said plate;
 - a post-receiving socket portion welded to said dome.
48. A method of manufacturing a ground spike comprising:
 - cutting a first blade material;

stamping reinforcement deformations in said first blade material;
folding said first blade material along a first longitudinal fold line to form two blades;
cutting a second blade material;
stamping reinforcement deformations in said second blade material;
folding said second blade material along a second longitudinal fold line to form two blades;
welding said first blade material to said second blade material along said first and second longitudinal fold lines to form a blade portion;
cutting a plate material comprising four sides;
welding said blade portion to said plate.

49. The method of claim 48 further comprising:
cutting a socket-shaped material;
stamping reinforcement lines in said socket-shaped material;
folding said socket-shaped material to form four substantially perpendicular socket walls;
cutting a plate material comprising four sides;
welding the four sides of the plate material to the four substantially perpendicular socket walls of the socket-shaped material.
50. The method of claim 49 wherein cutting the socket-shaped material comprises cutting opposing clamping tabs; further comprising:
cutting opposing fastener apertures in clamping tabs; and
folding said socket-shaped material to form said two opposing clamping tabs.
51. The method of claim 50 further comprising stamping reinforcement deformations in said plate material.

52. The method of claim 51 wherein said reinforcement deformations comprise folding outer edges at an angle between 80 degrees and 120 degrees.
53. The method of claim 51 wherein said reinforcement deformations comprise stamping reinforcement lines.
54. The method of claim 50 further comprising cutting the corners off said plate.
55. The method of claim 50 wherein said socket-shaped material is cut from a first thickness of metal; said plate material is cut from a second thickness of metal; and said first and second blade materials are cut from a third thickness of metal; wherein said first, second and third thicknesses are between 1.5 mm and 4.0 mm.
56. The method of claim 55 wherein said second thickness of metal is thicker than said first and third thicknesses of metal.
57. The method of claim 56 wherein said third thickness of metal is thicker than said first thicknesses of metal.
58. The method of claim 55 wherein said first thickness of metal is between 1.5 mm and 2.5 mm; said second thickness of metal is between 2.0 mm and 4.0 mm; and said third thickness of metal is between 1.5 mm and 2.5 mm.
59. The method of claim 55 wherein said first thickness of metal is between 1.7 mm and 1.9 mm; said second thickness of metal is between 2.4 mm and 3.0 mm; and said third thickness of metal is between 1.7 mm and 1.9 mm.

60. The method of claim 58 wherein said cutting the socket-shaped material and said stamping of reinforcement lines in said socket-shaped material occur contemporaneously by using a progressive die.
61. The method of claim 58 further comprising powder coating the ground spike.
62. A method of installing the ground spike of claim 1 comprising
 - placing a target object on the plate;
 - hammering the target object downward until the plate rests at the desired level relative to the ground;
 - securing an object to the plate.
63. The method of claim 62 wherein placing a target object on the plate comprises placing a target object in a post receiving socket, and wherein securing an object to the plate comprises securing a post to a post receiving socket.
64. The method of claim 63 wherein hammering the target object downward comprises hammering with a sledge hammer or mallet.

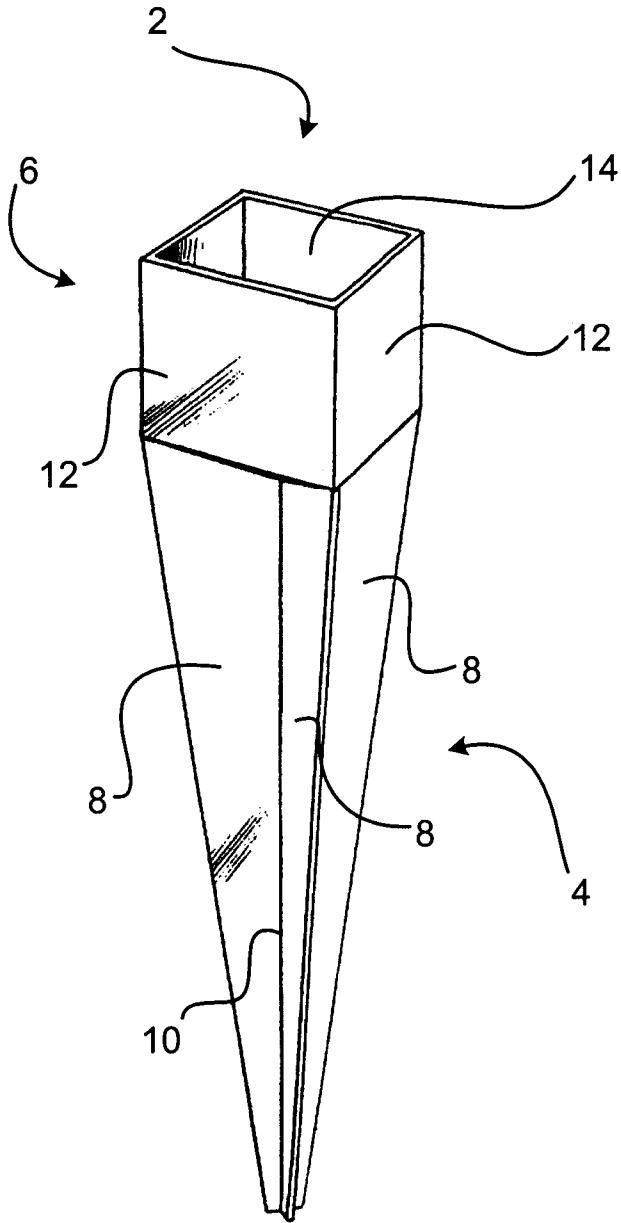

Fig. 1
(Prior Art)

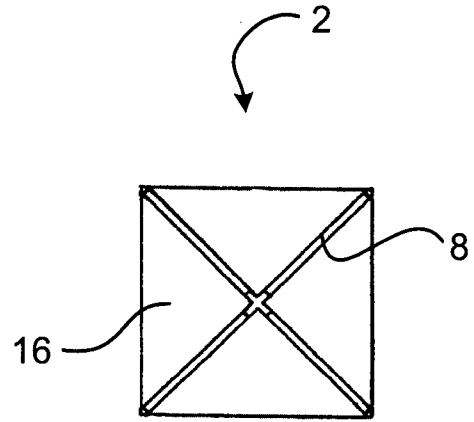

Fig. 2
(Prior Art)

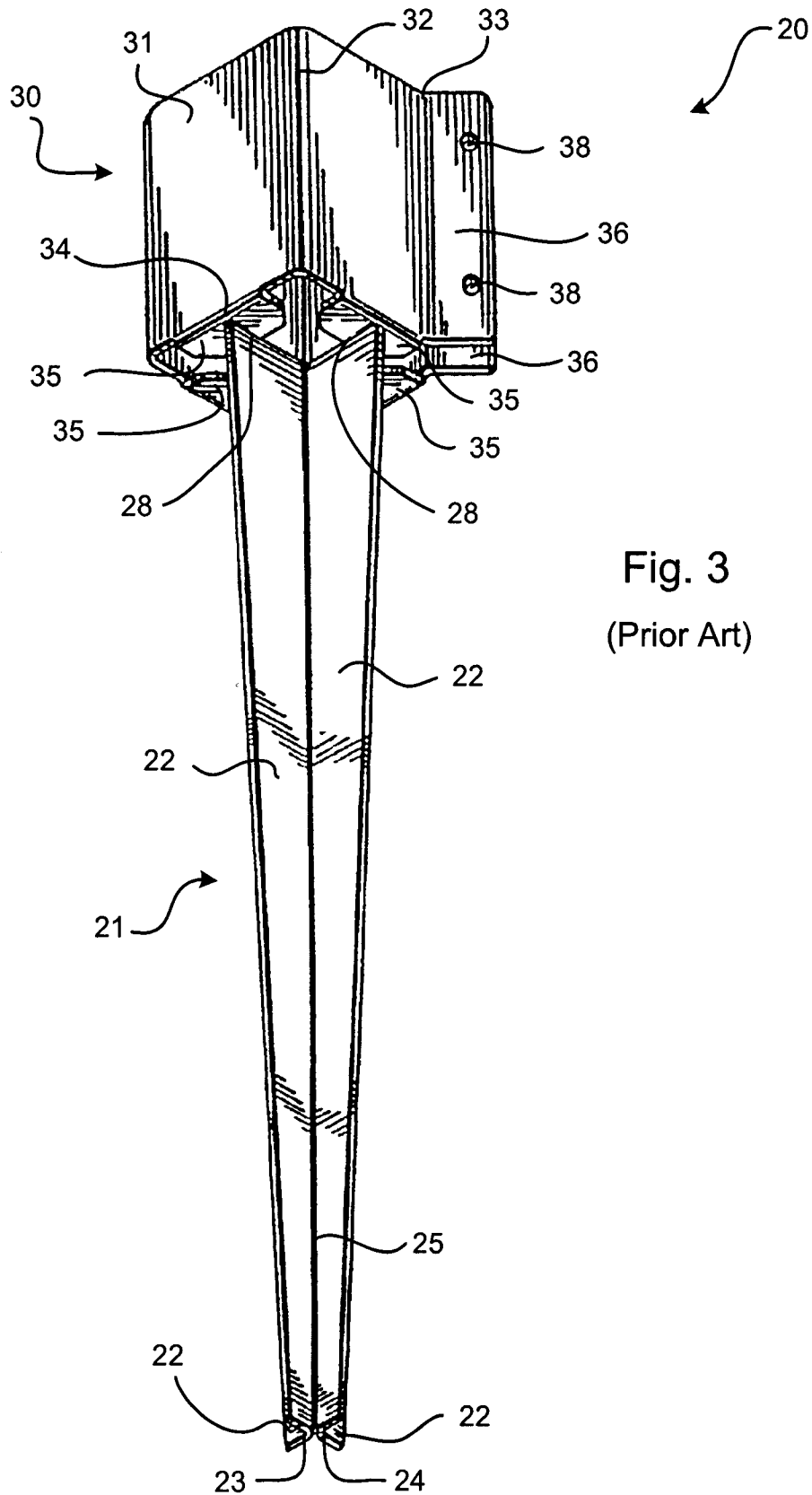

Fig. 3
(Prior Art)

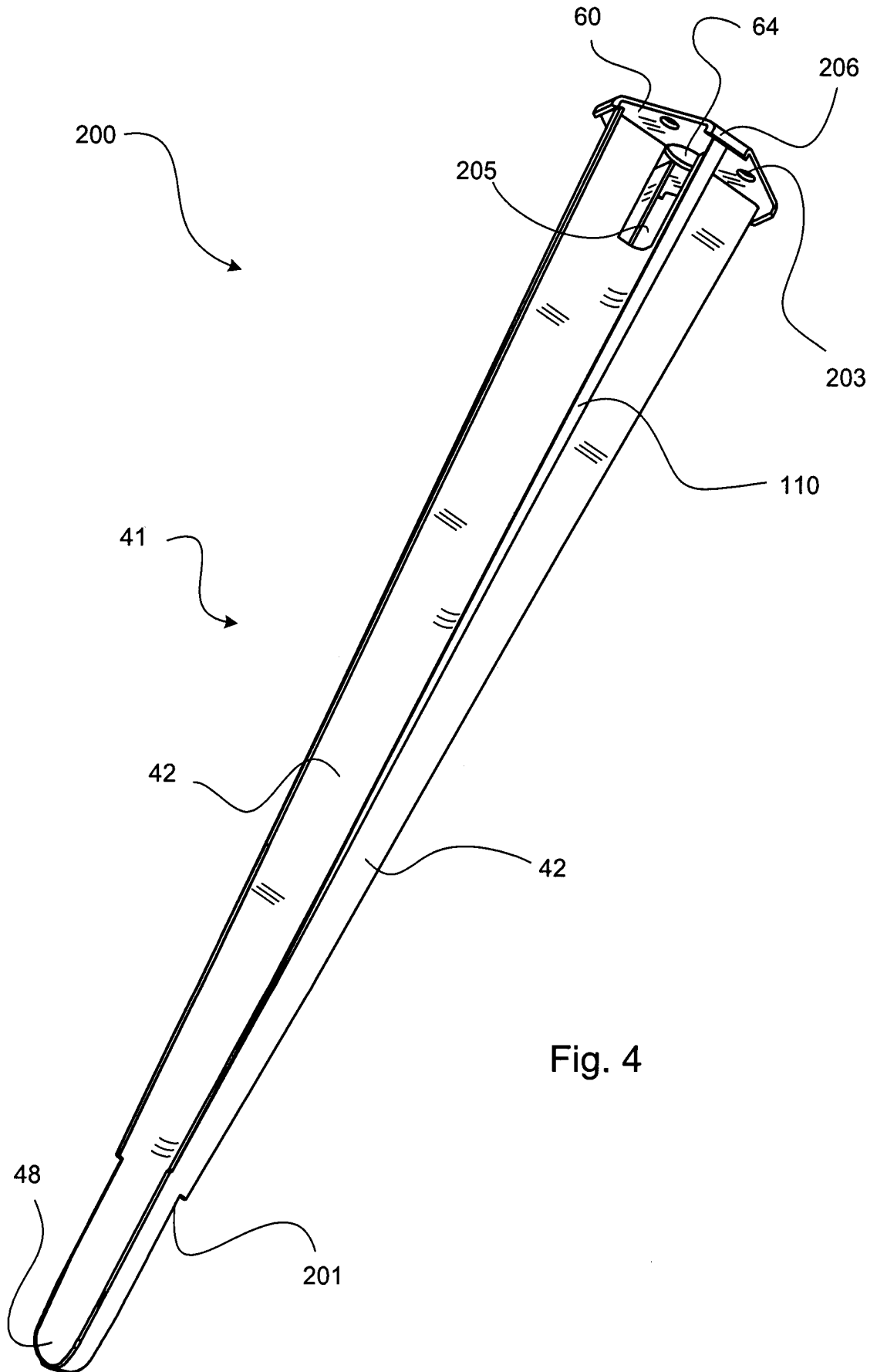

Fig. 4

4/21

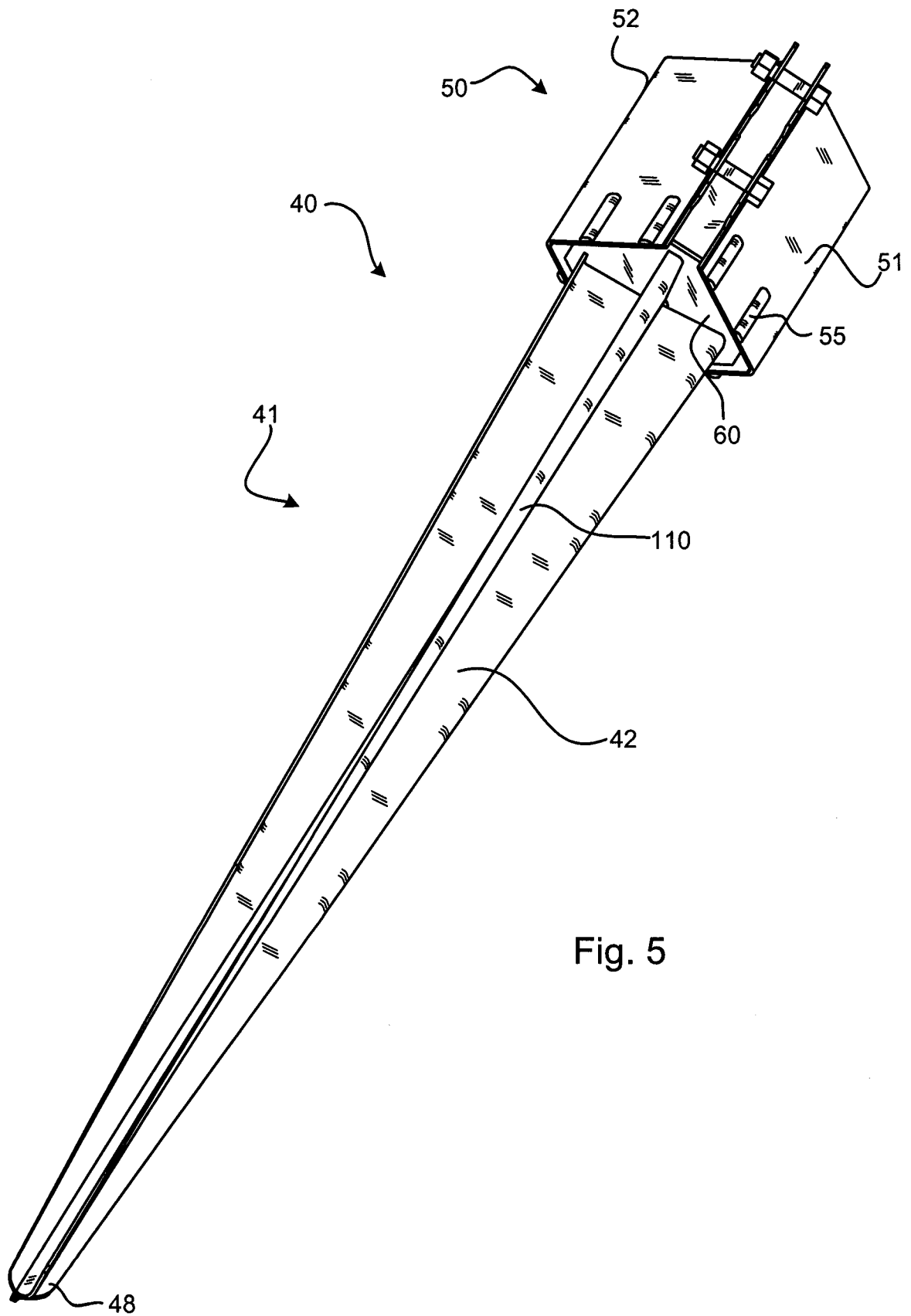

Fig. 5

5/21

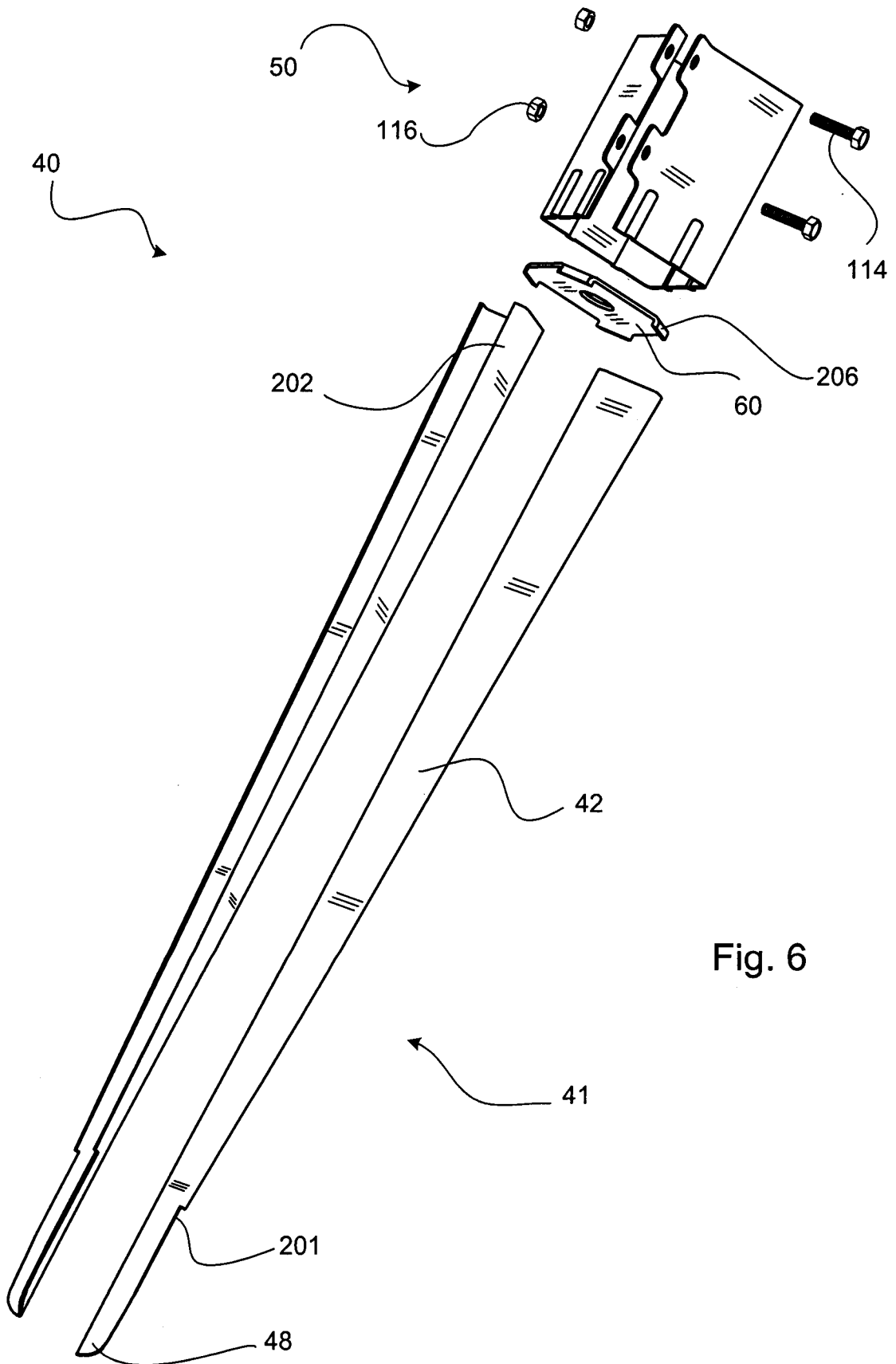

Fig. 6

6/21

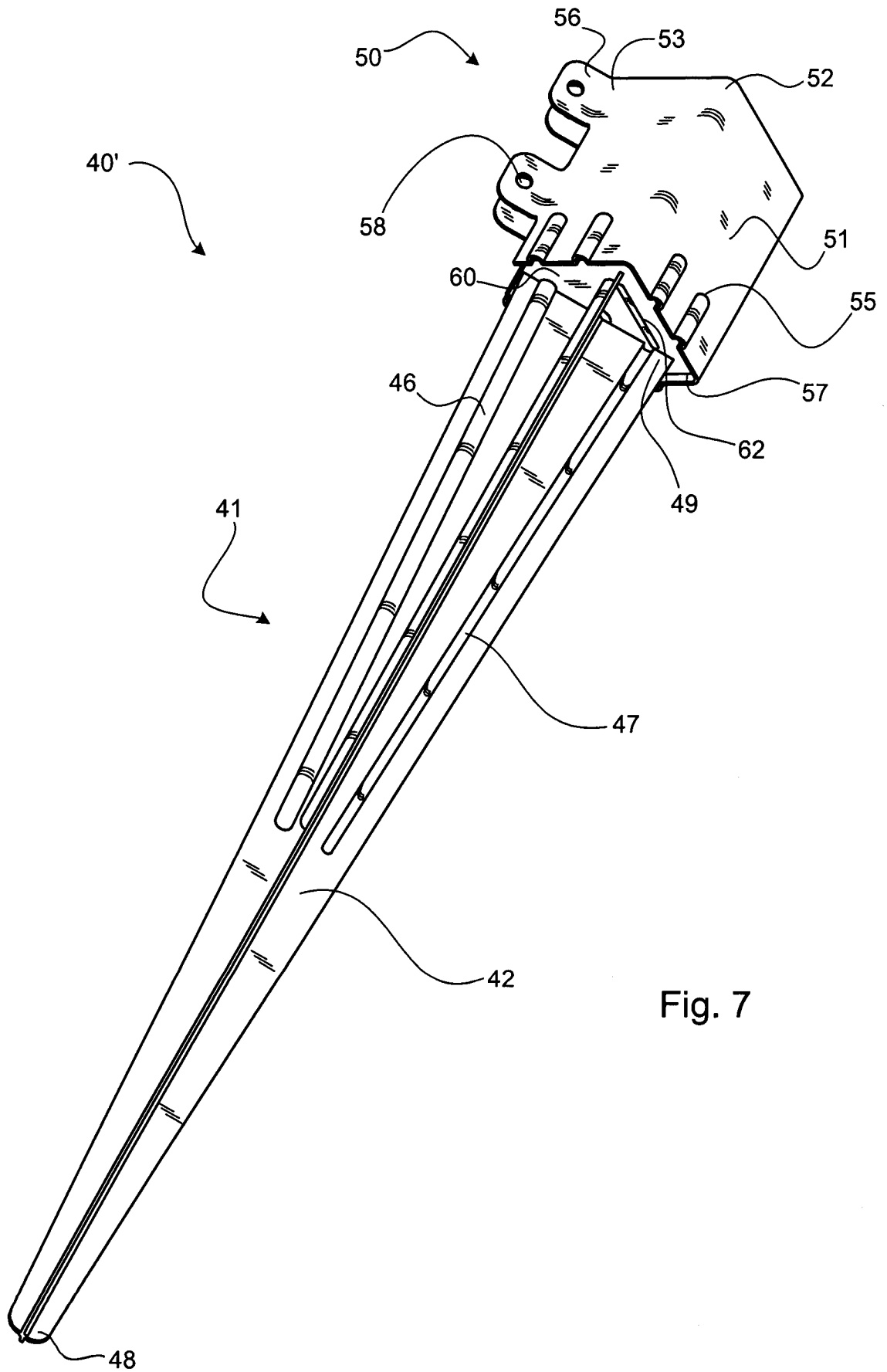

Fig. 7

Fig. 8 200

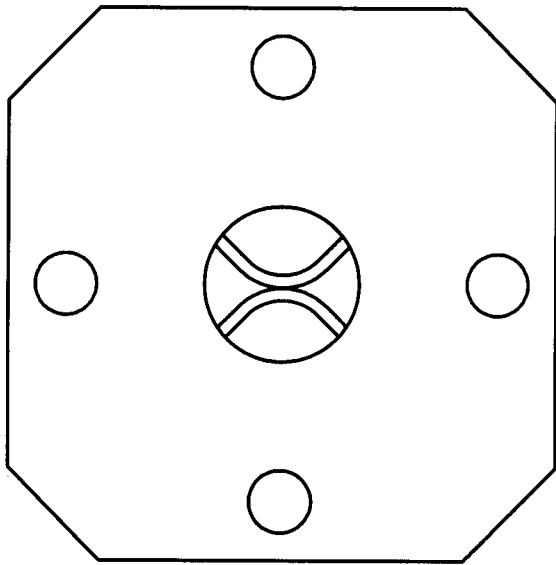
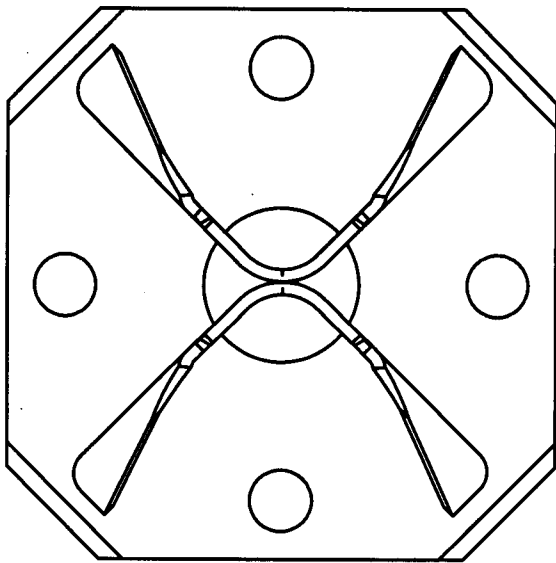
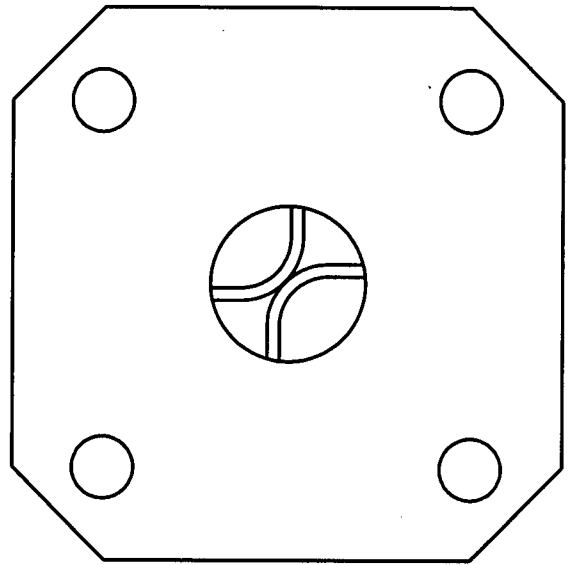
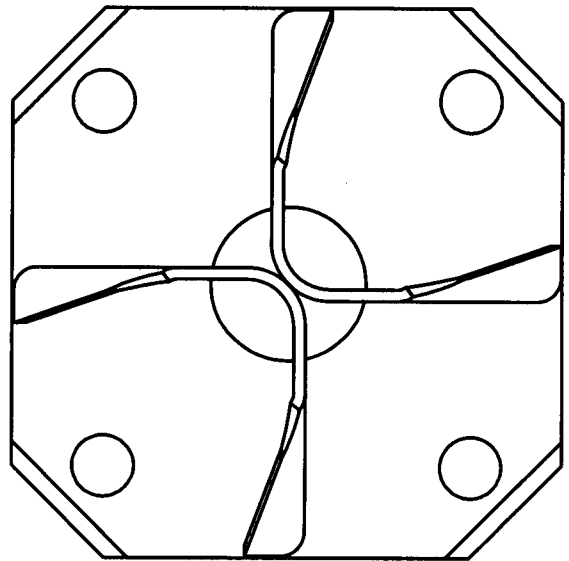

Fig. 10 208



200

Fig. 9



208

Fig. 11

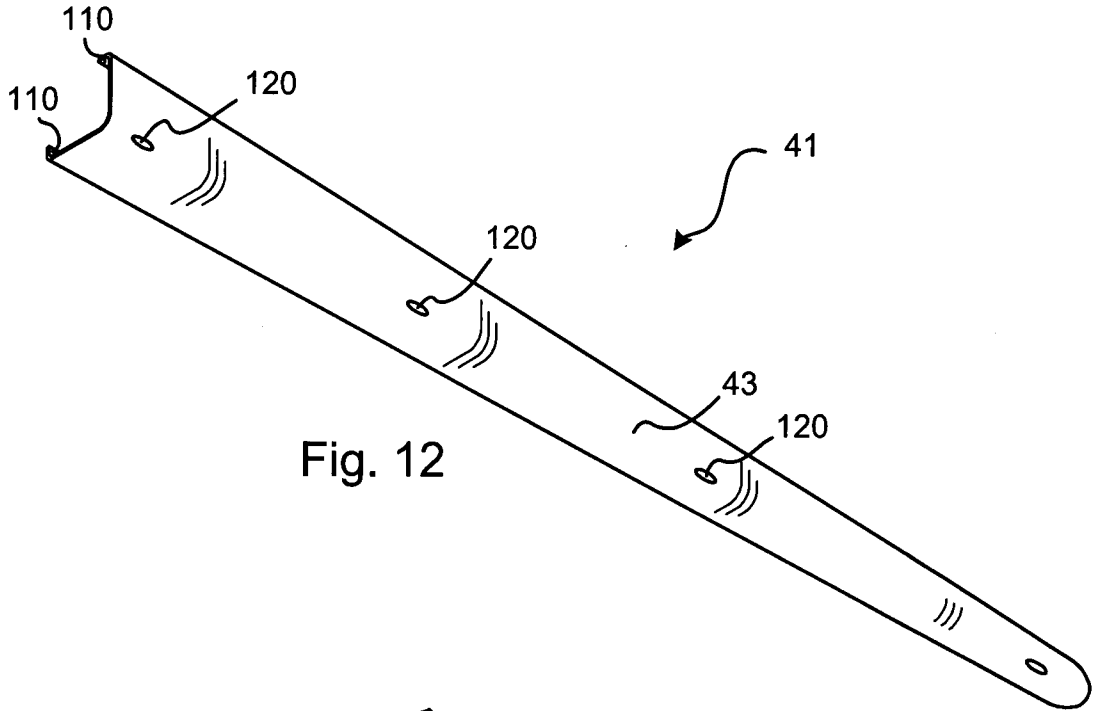

Fig. 12

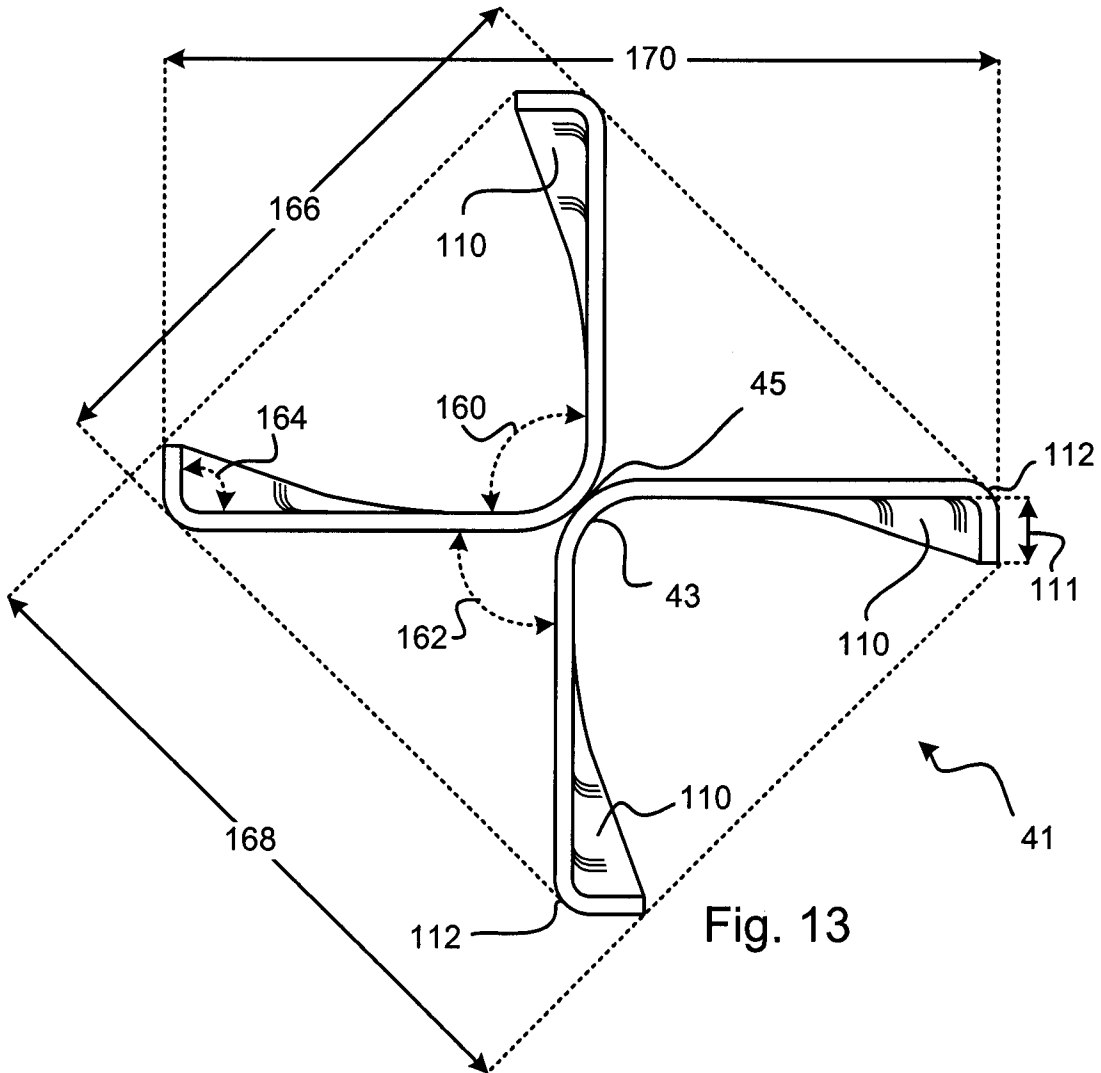

Fig. 13

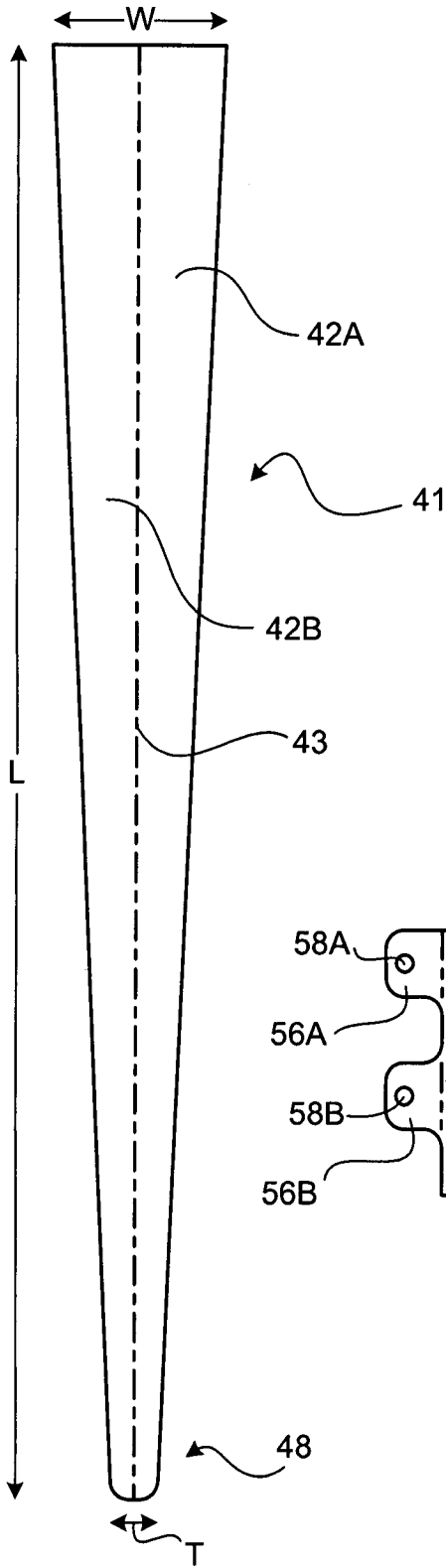

Fig. 14

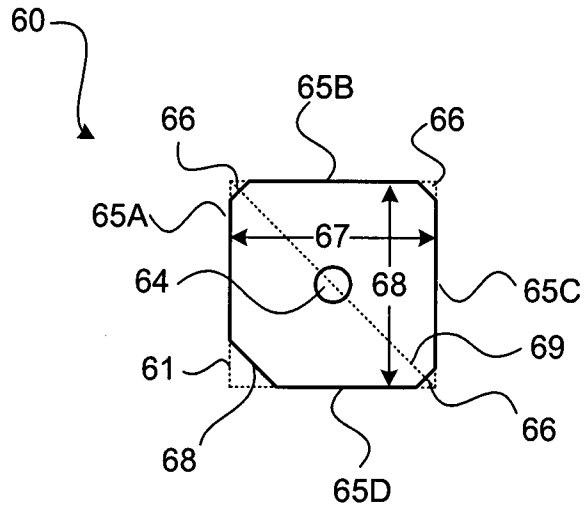

Fig. 15

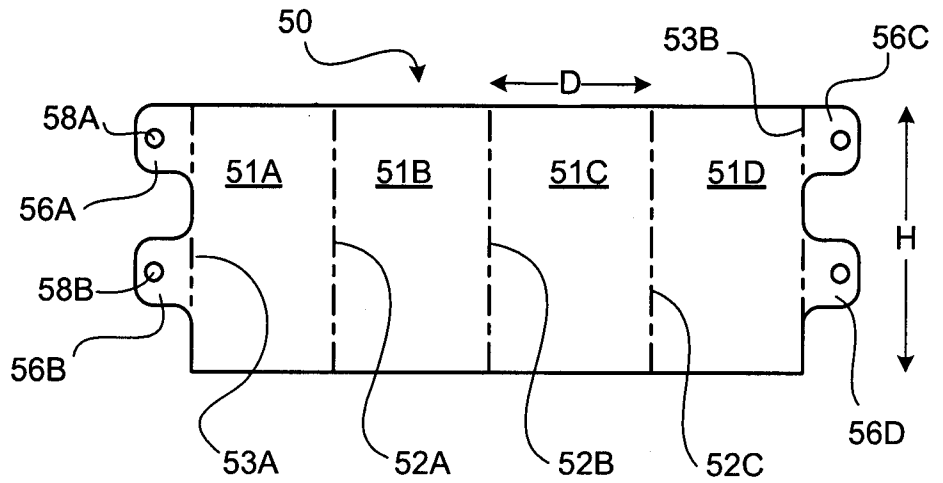

Fig. 16

10/21

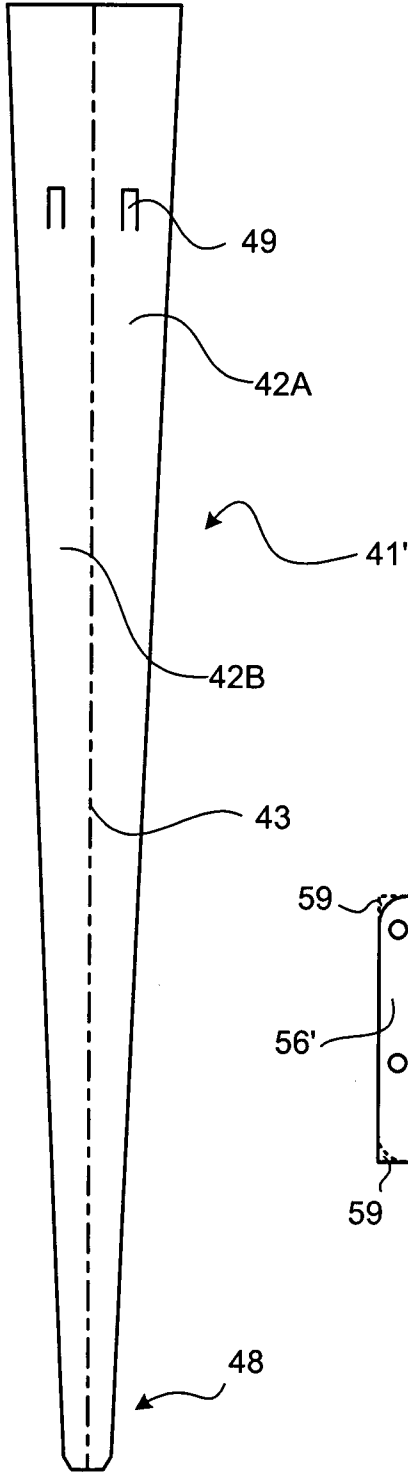

Fig. 17

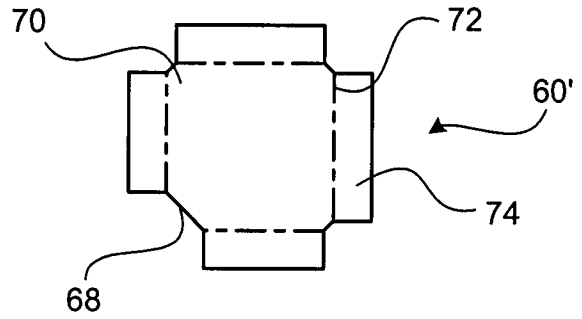

Fig. 19

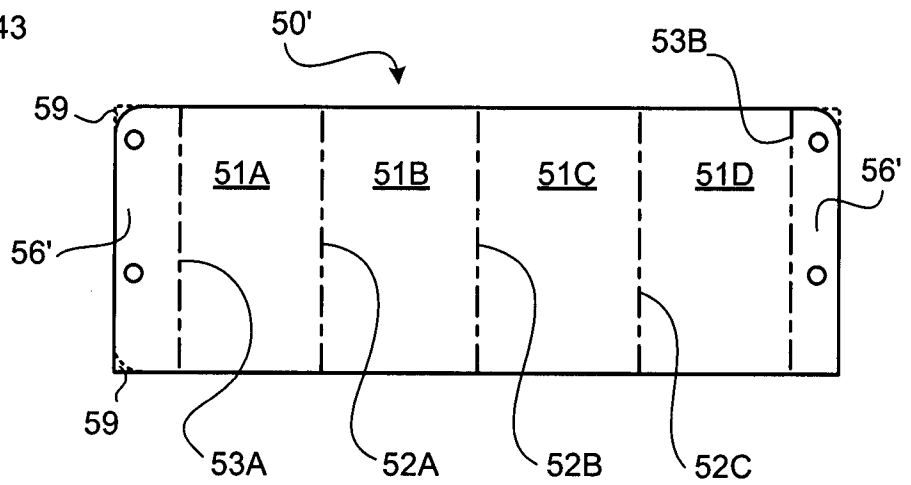

Fig. 18

11/21

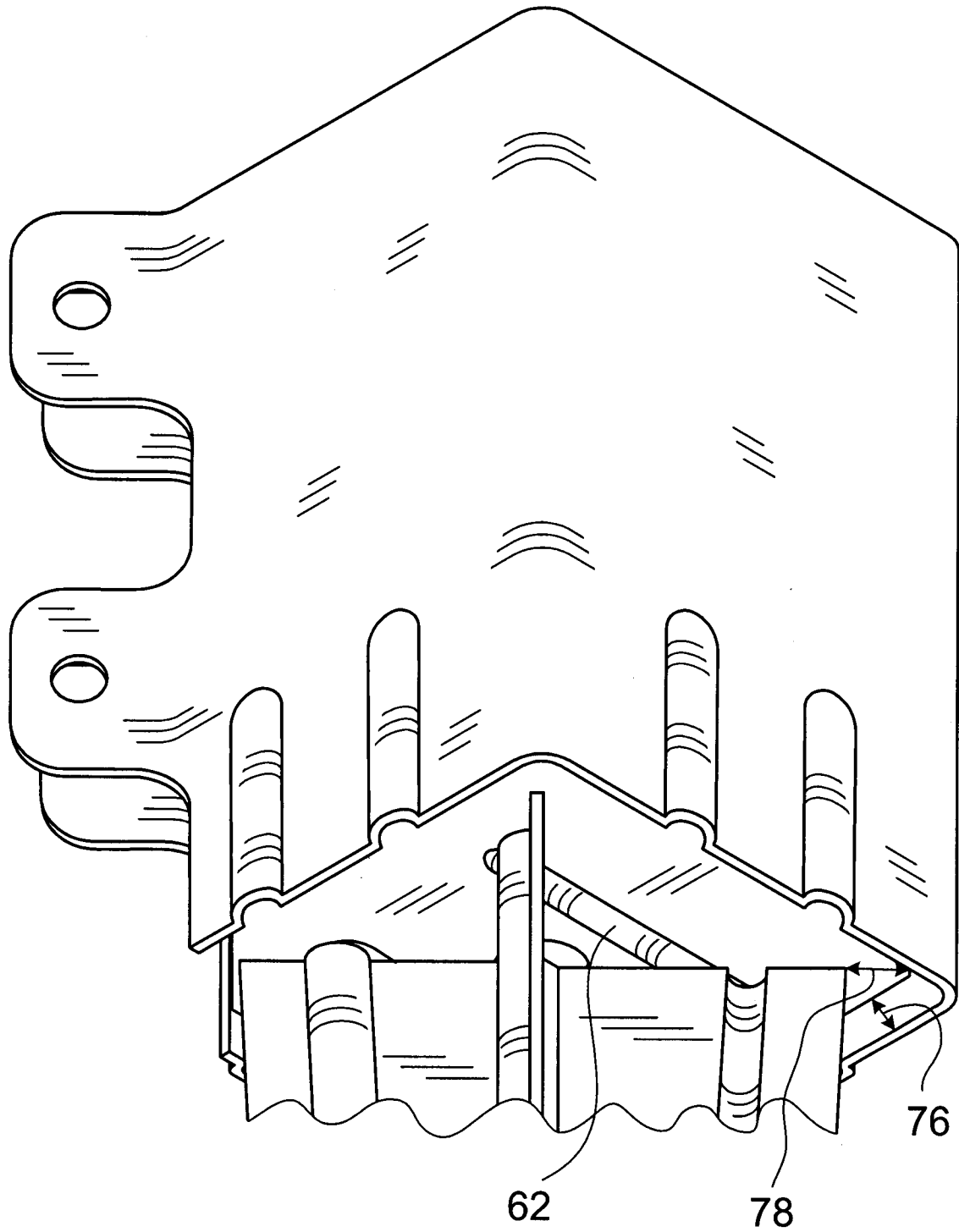

Fig. 20

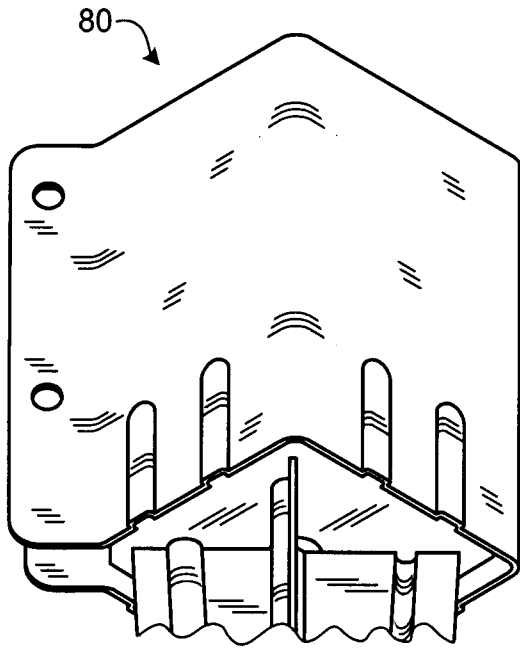

Fig. 21

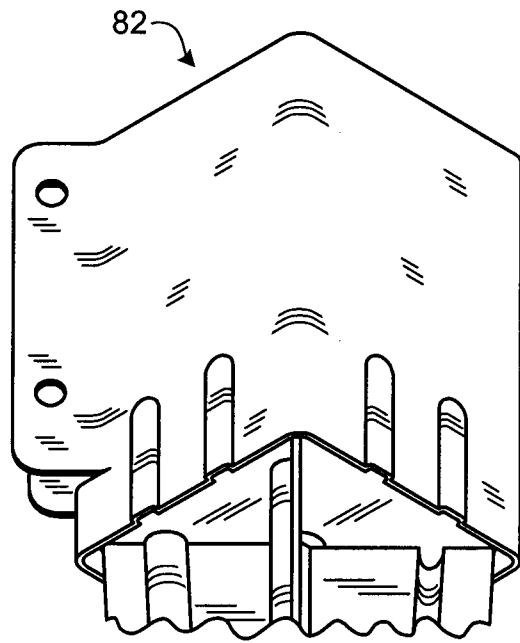

Fig. 22

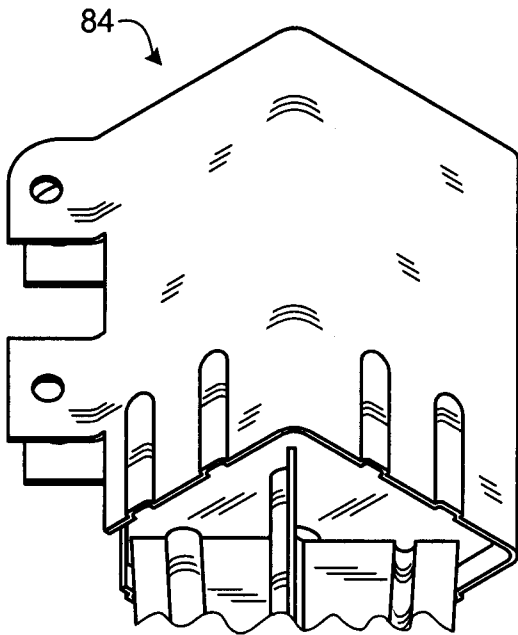

Fig. 23

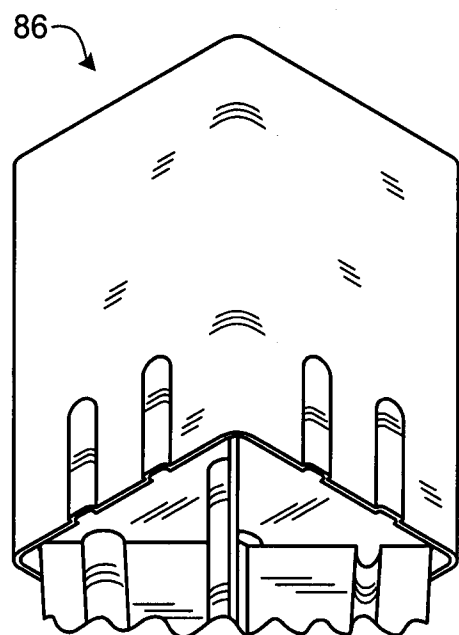

Fig. 24

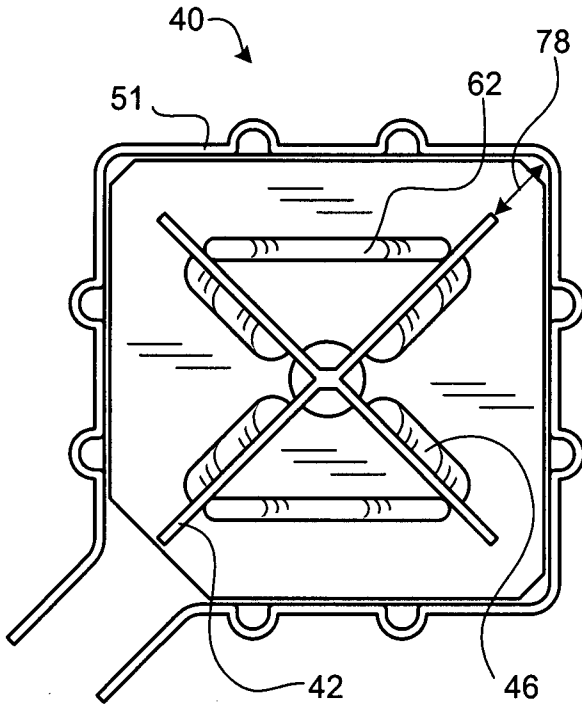

Fig. 25

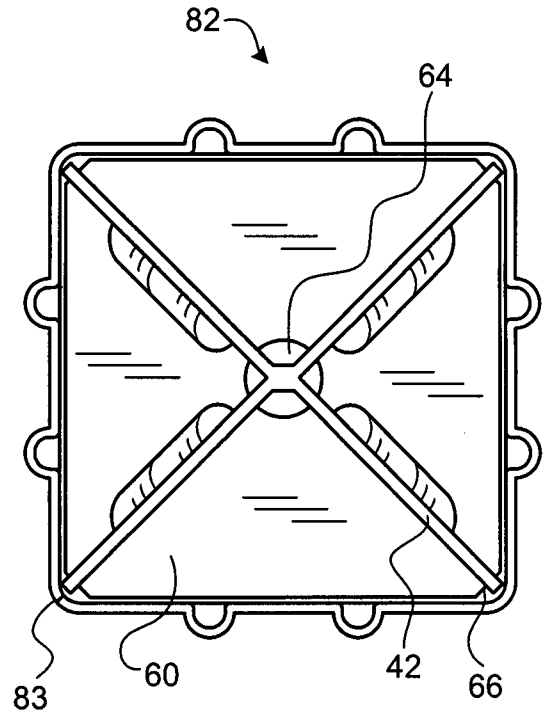

Fig. 26

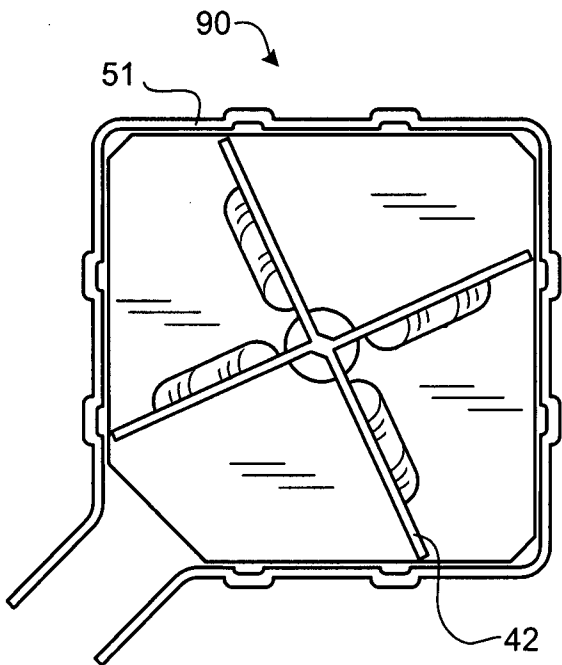

Fig. 27

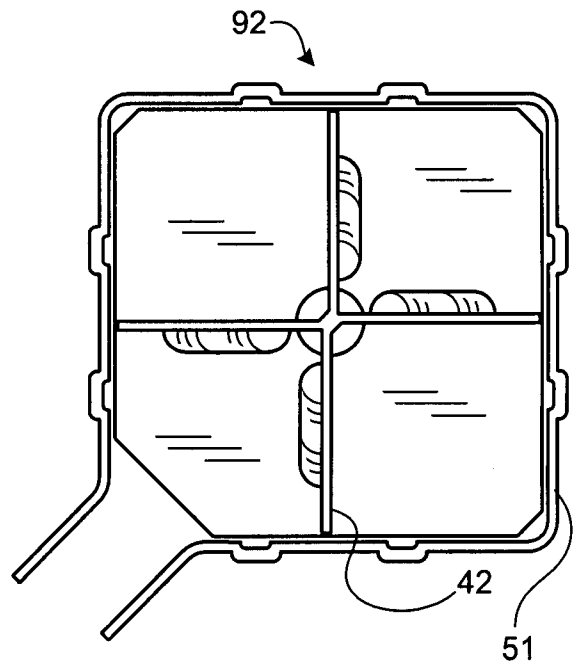

Fig. 28

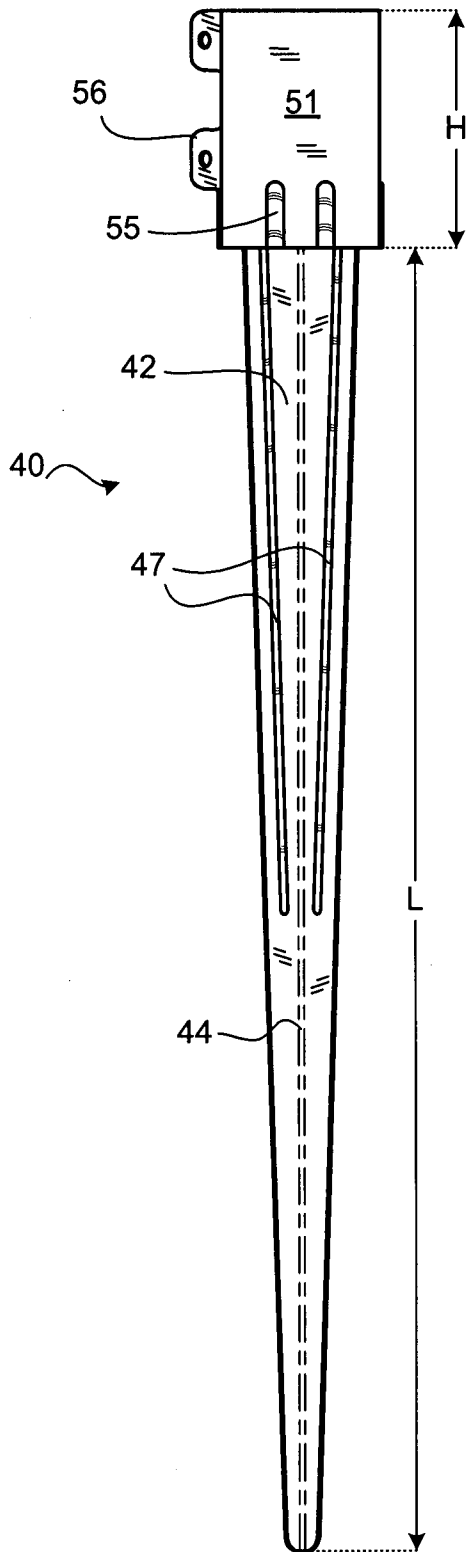

Fig. 29

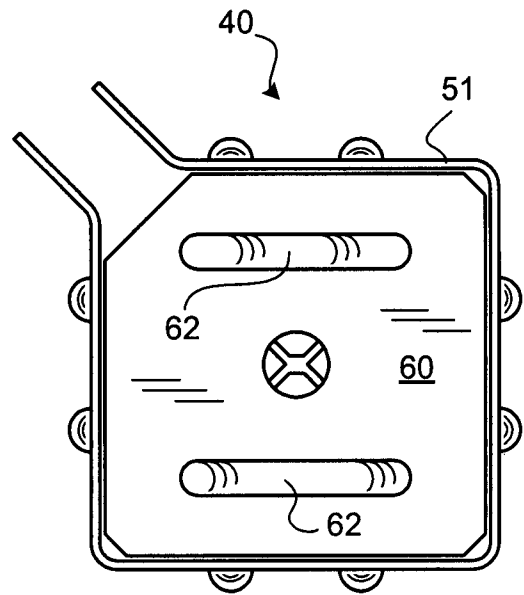

Fig. 30

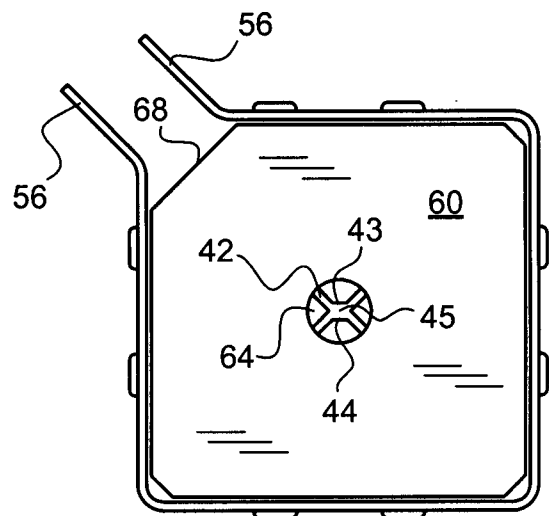

Fig. 31

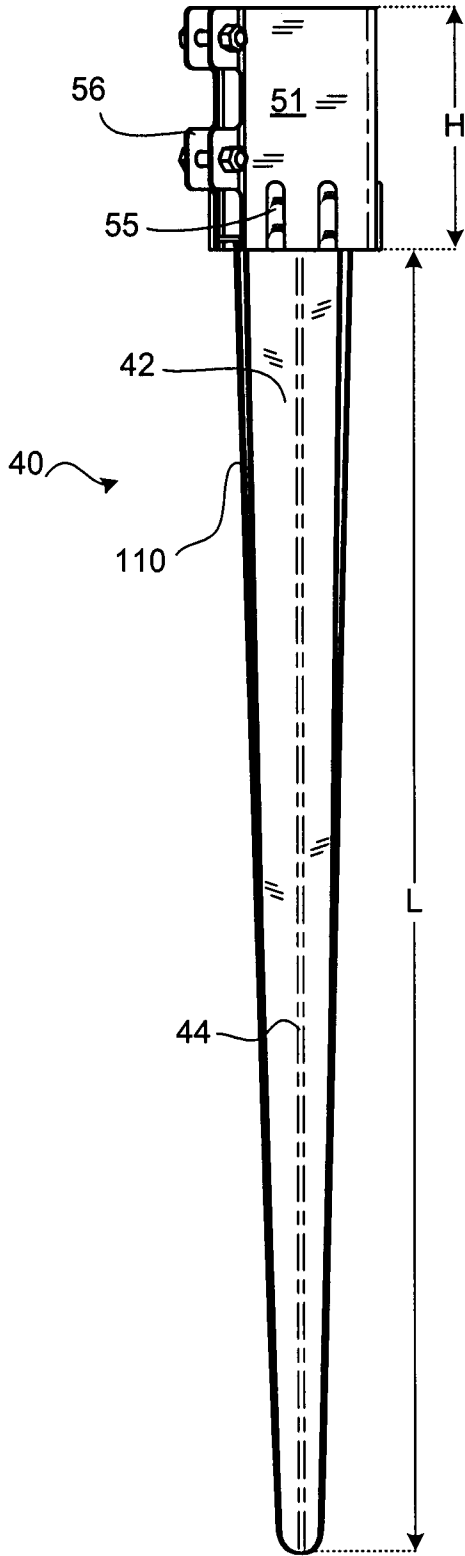

Fig. 32

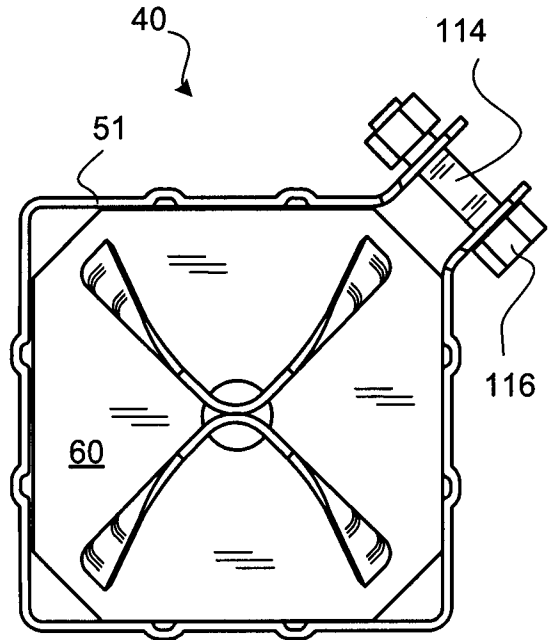

Fig. 33

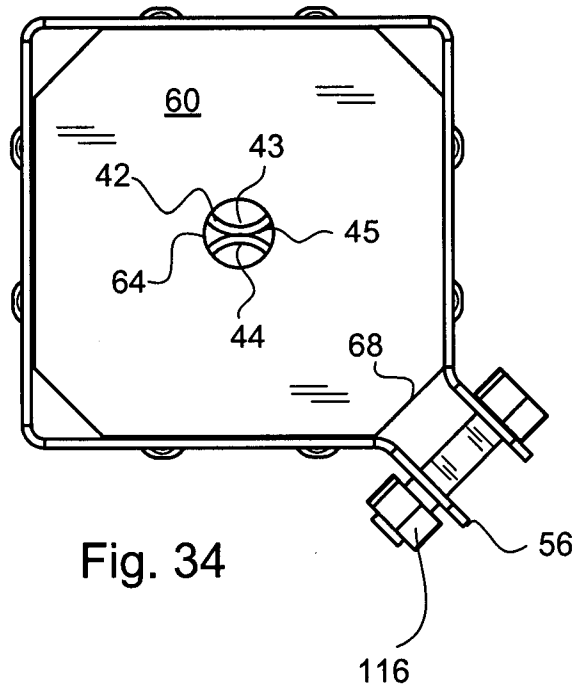

Fig. 34

16/21

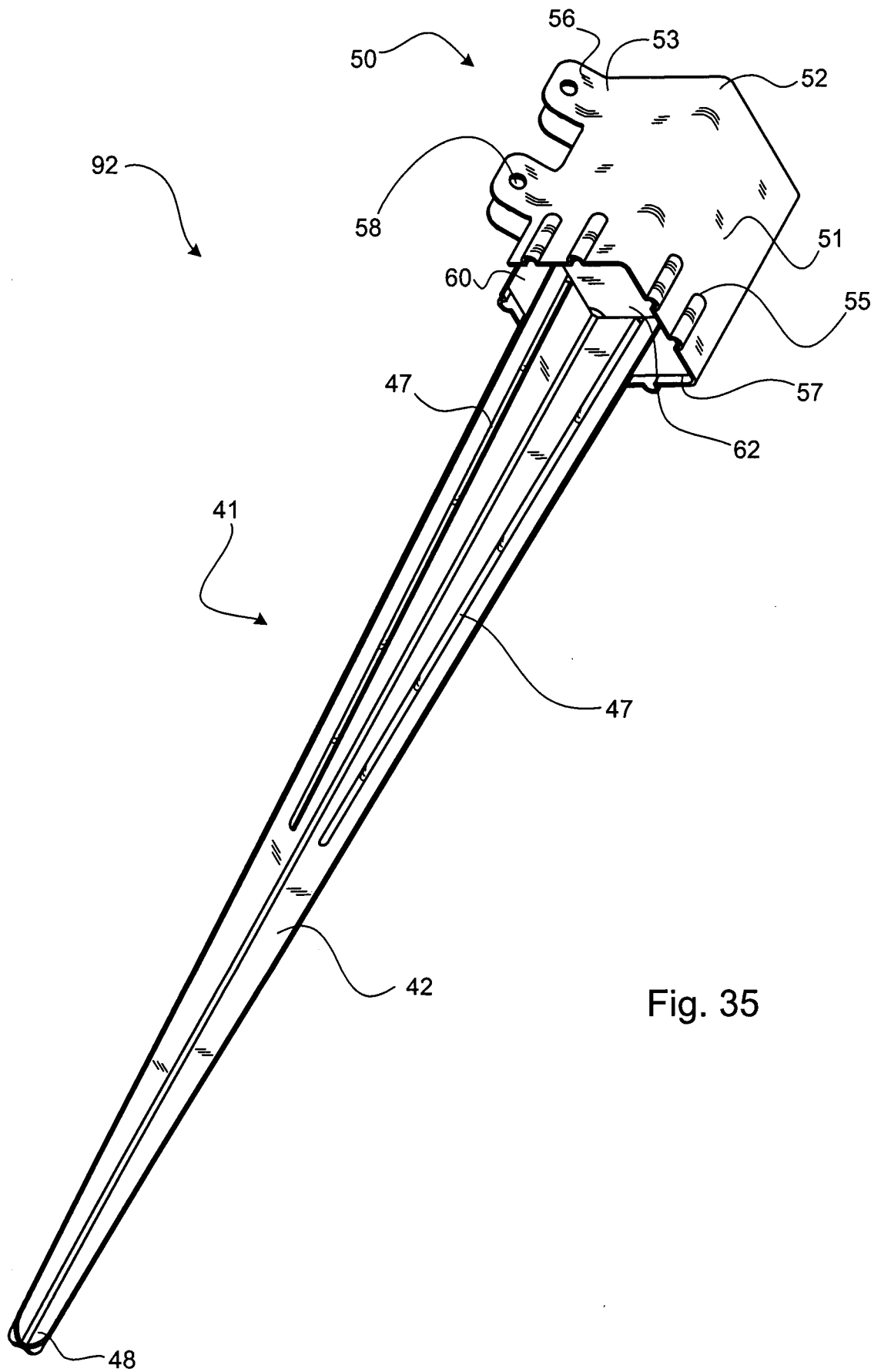

Fig. 35

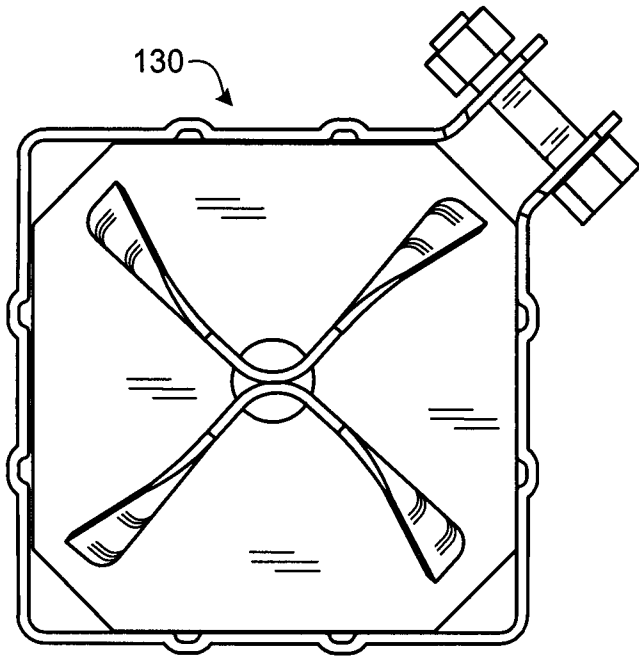

Fig. 36

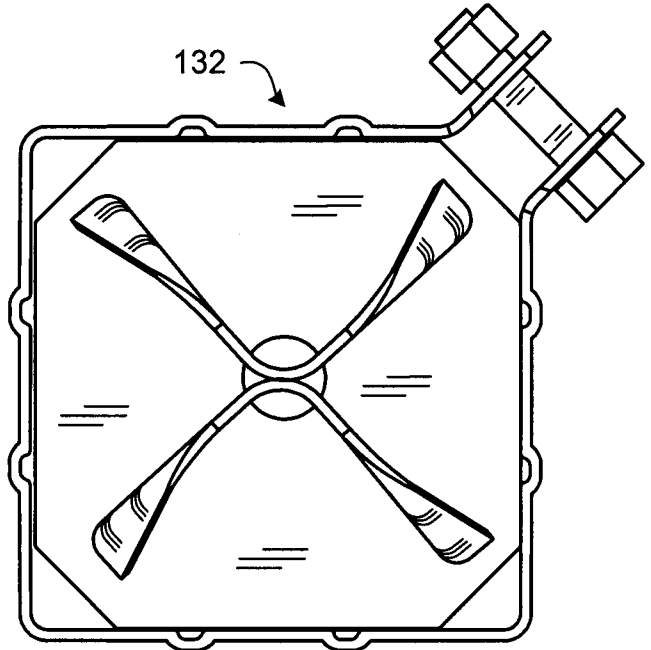

Fig. 37

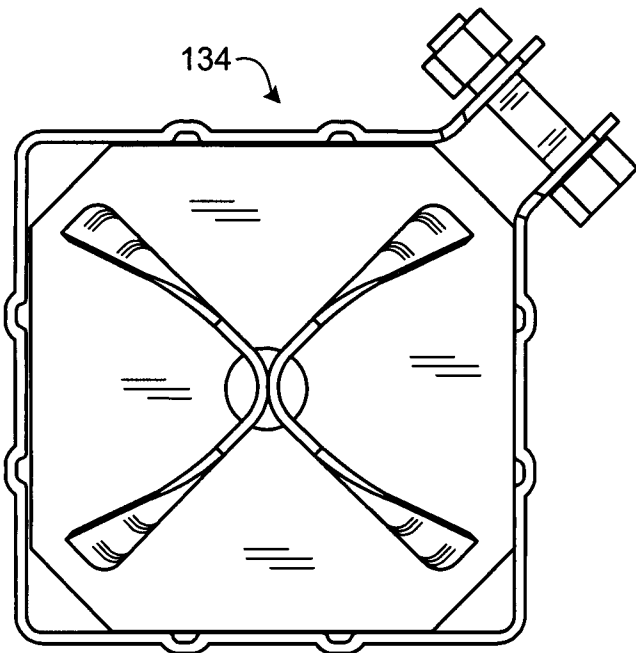

Fig. 38

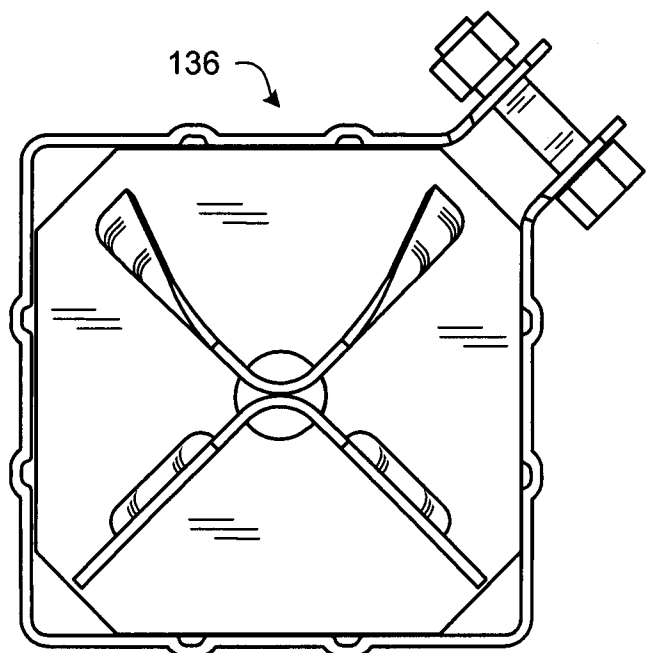

Fig. 39

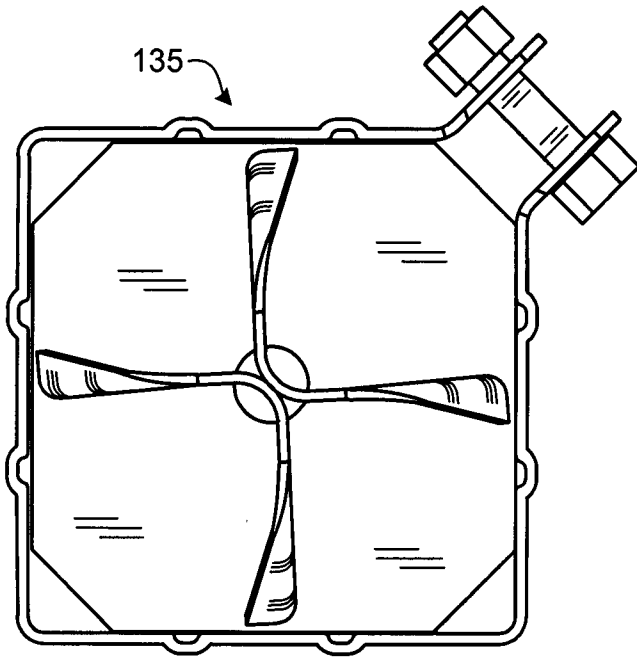

Fig. 40

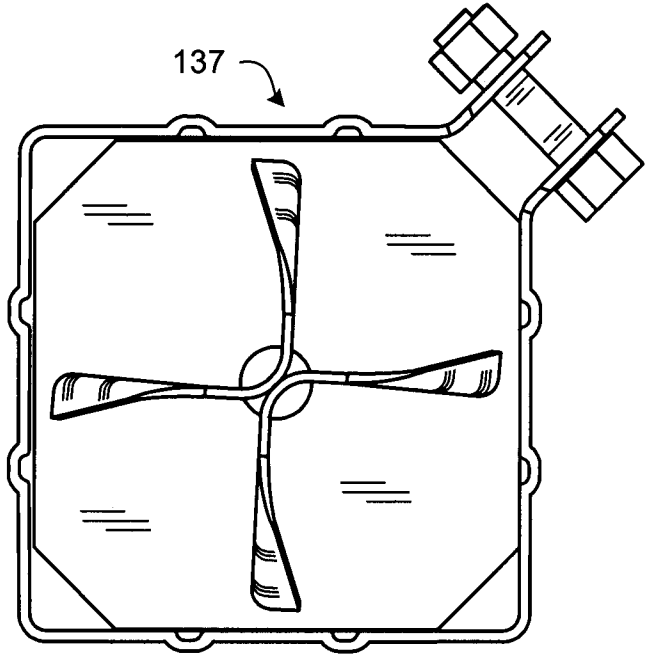

Fig. 41

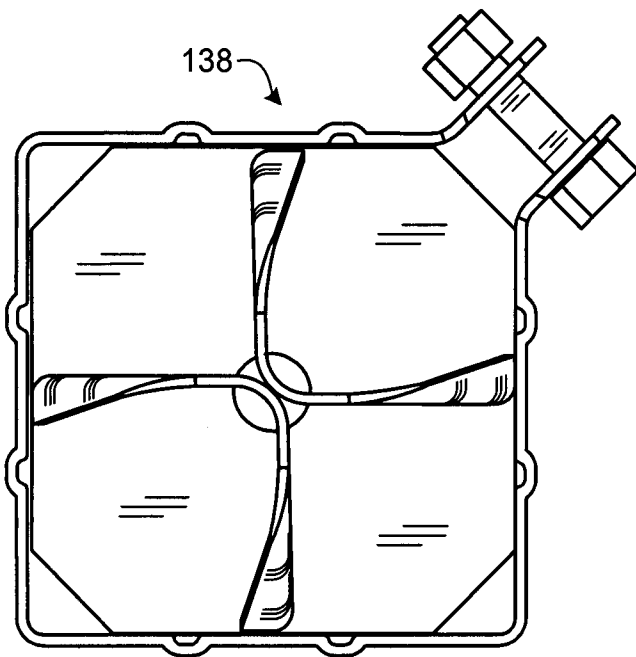

Fig. 42

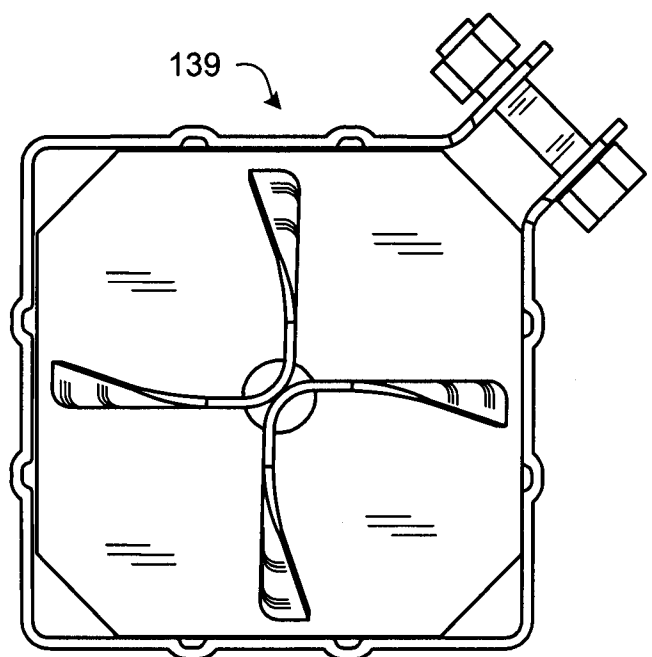

Fig. 43

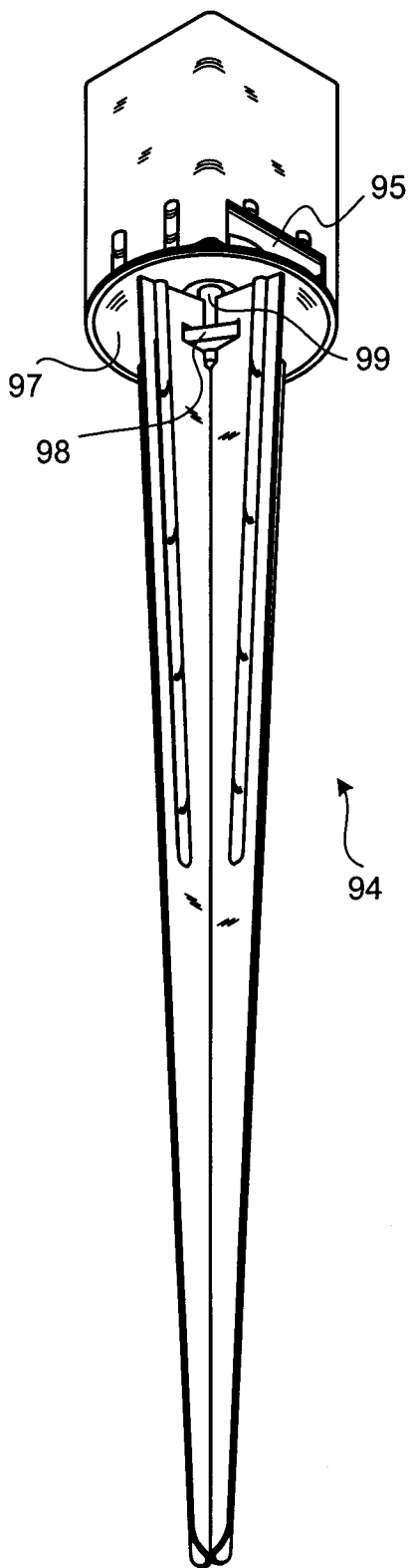

Fig. 44

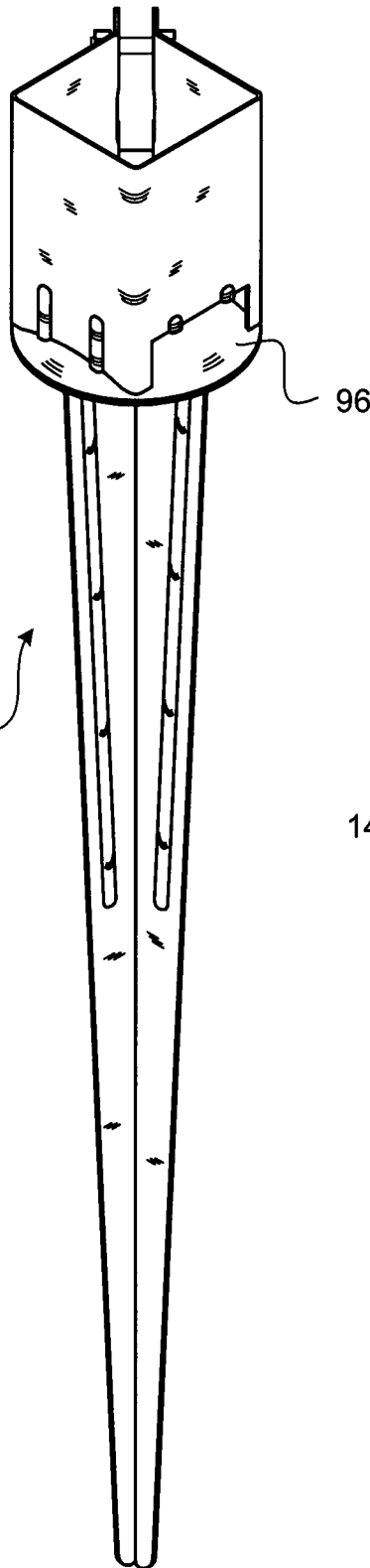

Fig. 45

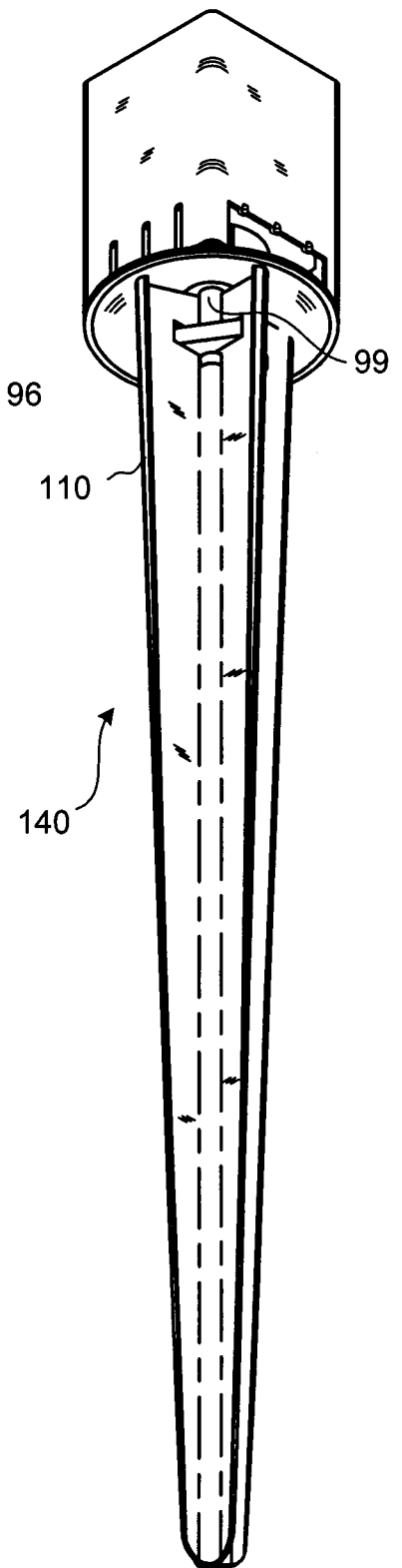

Fig. 46

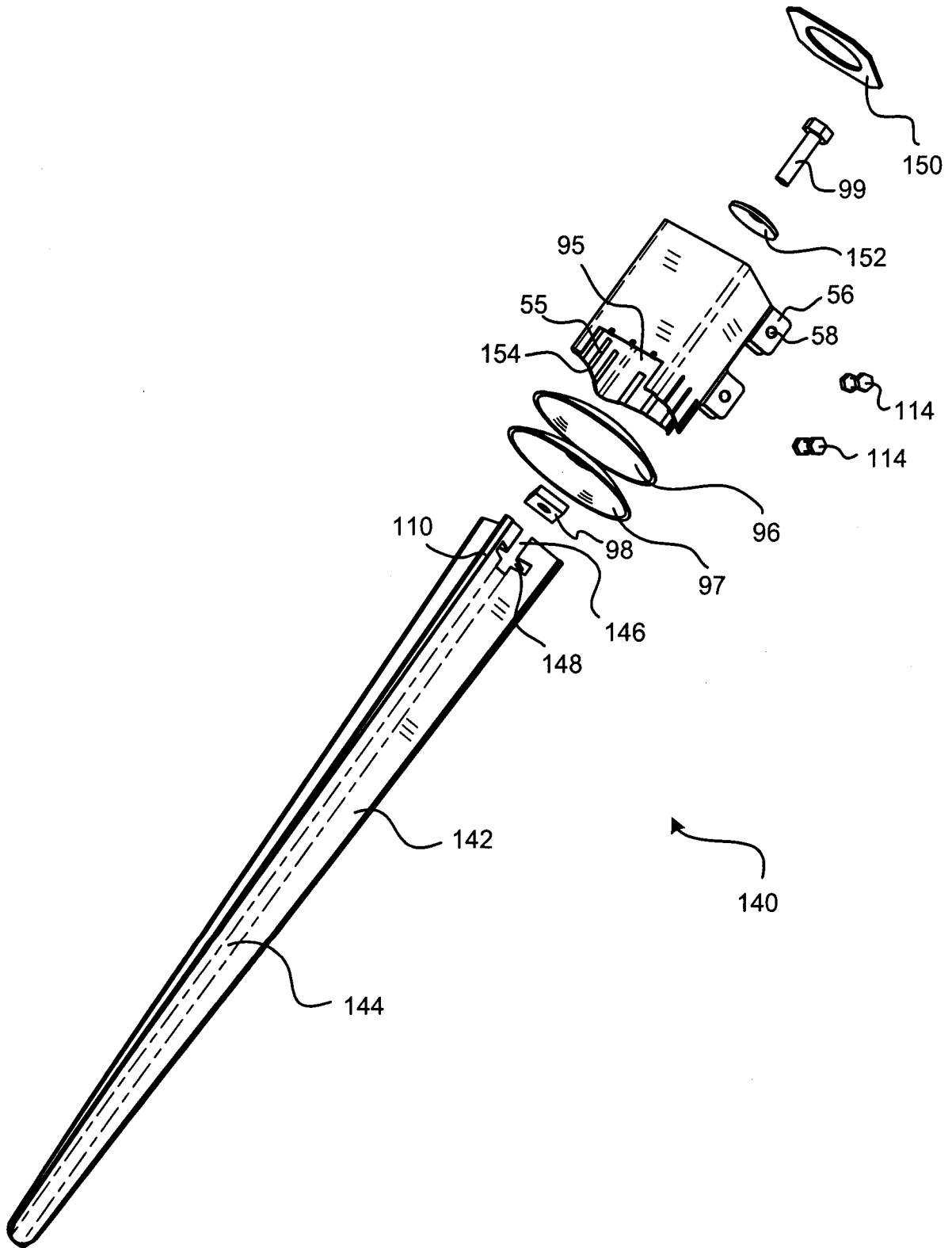

Fig. 47

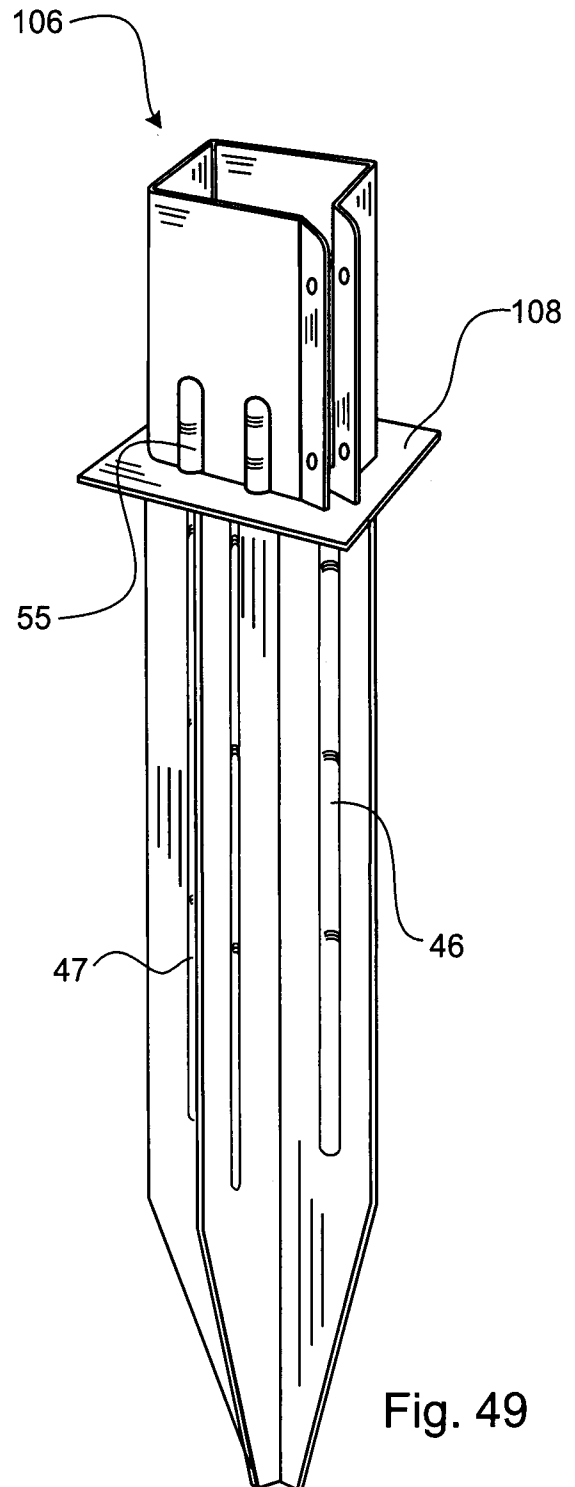
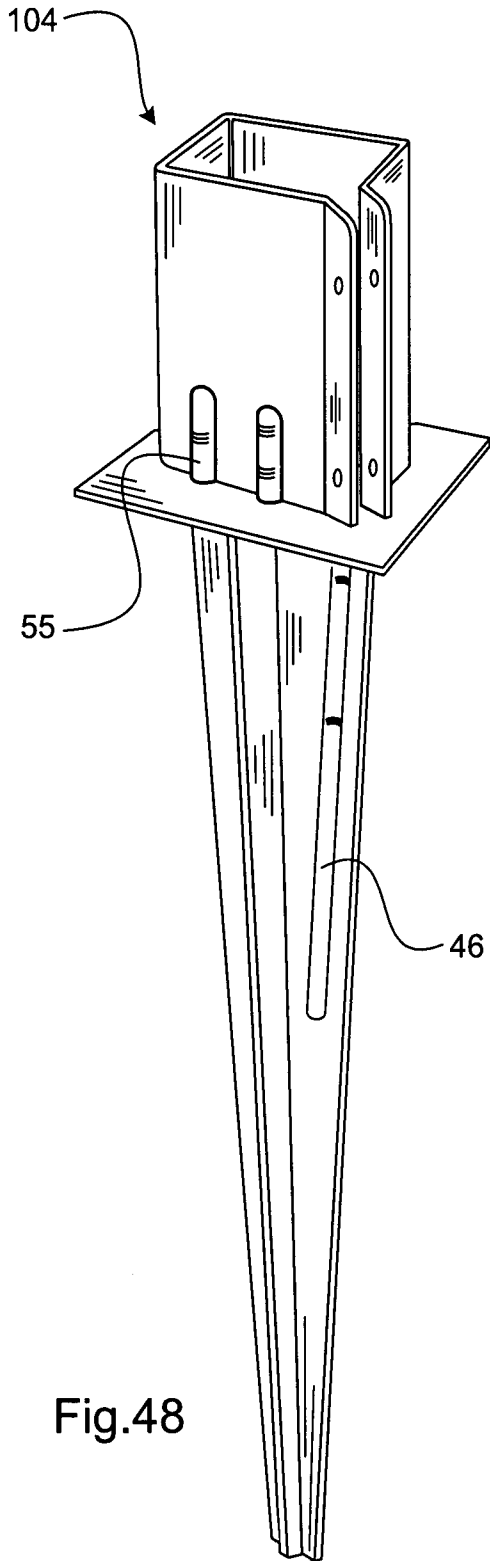

Fig.48

Fig. 49

INTERNATIONAL SEARCH REPORT

International application No.
PCT/CA2007/001813

A. CLASSIFICATION OF SUBJECT MATTER
 IPC: **E04H 12/22** (2006.01) , **B23P 15/00** (2006.01) , **E02D 5/74** (2006.01) , **E02D 5/80** (2006.01) ,
E04H 17/22 (2006.01)
 According to International Patent Classification (IPC) or to both national classification and IPC

B. FIELDS SEARCHED
 Minimum documentation searched (classification system followed by classification symbols)
 IPC(2006.01) E04H 12/22, E04H 17/22; E02D 5/80, E02D 5/74
 US: 248/530, 052/165, 248/545, 256/065.14, 052/155

Documentation searched other than minimum documentation to the extent that such documents are included in the fields searched

Electronic database(s) consulted during the international search (name of database(s) and, where practicable, search terms used)
 Canadian Patent Database; Delphion
 Keywords: Spike, reinforced, support, post, ground, anchor, strengthened, blade

C. DOCUMENTS CONSIDERED TO BE RELEVANT

Category*	Citation of document, with indication, where appropriate, of the relevant passages	Relevant to claim No.
Y	US 6039298 (STEIR, P.) March 21 2000 (21-03-2000) *Whole document*	1-27, 45-63
Y	US 4651399 (MORALY, E.) March 24 1987 (24-03-1987) *Whole document*	1-27, 47-63
Y	US 6273390 B (MEYER, G.) August 14 2001 (14-08-2001) *Whole document*	45-46

Further documents are listed in the continuation of Box C. See patent family annex.

* Special categories of cited documents :	"T" later document published after the international filing date or priority date and not in conflict with the application but cited to understand the principle or theory underlying the invention
"A" document defining the general state of the art which is not considered to be of particular relevance	"X" document of particular relevance; the claimed invention cannot be considered novel or cannot be considered to involve an inventive step when the document is taken alone
"E" earlier application or patent but published on or after the international filing date	"Y" document of particular relevance; the claimed invention cannot be considered to involve an inventive step when the document is combined with one or more other such documents, such combination being obvious to a person skilled in the art
"L" document which may throw doubts on priority claim(s) or which is cited to establish the publication date of another citation or other special reason (as specified)	"&" document member of the same patent family
"O" document referring to an oral disclosure, use, exhibition or other means	
"P" document published prior to the international filing date but later than the priority date claimed	

Date of the actual completion of the international search 15 January 2008 (15-01-2008)	Date of mailing of the international search report 28 January 2008 (28-01-2008)
-------------------------------------------------------------------------------------------	------------------------------------------------------------------------------------

Name and mailing address of the ISA/CA Canadian Intellectual Property Office Place du Portage I, C114 - 1st Floor, Box PCT 50 Victoria Street Gatineau, Quebec K1A 0C9 Facsimile No.: 001-819-953-2476	Authorized officer Victoria Dempster 819- 934-4272
-----------------------------------------------------------------------------------------------------------------------------------------------------------------------------------------------------------------------	------------------------------------------------------------------

INTERNATIONAL SEARCH REPORT
Information on patent family members

International application No.
PCT/CA2007/001813

Patent Document Cited in Search Report	Publication Date	Patent Family Member(s)	Publication Date
US6039298	21-03-2000	NONE	
US4651399		AT16951T T AU1334083 A BR8306194 A CA1213787 A1 DE3361456D D1 DK487483 A EP0102978 A1 ES278069U U FI70292B B FR2522711 A1 IL67971 A IT1163134 B JP58157534 A NO834035 A OA7580 A US4520545 A WO8303115 A1 ZA8301287 A	15-12-1985 18-10-1983 07-02-1984 11-11-1986 23-01-1986 24-10-1983 21-03-1984 01-08-1984 28-02-1986 09-09-1983 29-11-1985 08-04-1987 19-09-1983 04-11-1983 31-03-1985 04-06-1985 15-09-1983 26-10-1983
US6273390	14-08-2001	NONE	

- 26 -

59. The method of claim 57 wherein said cutting the socket-shaped material and said stamping of reinforcement lines in said socket-shaped material occur contemporaneously by using a progressive die.
- 5 60. The method of claim 57 further comprising powder coating the ground spike.
61. A method of installing the ground spike of claim 1 comprising
placing a target object on the plate;
10 hammering the target object downward until the plate rests at the desired level relative to the ground;
securing an object to the plate.
62. The method of claim 61 wherein placing a target object on the plate
15 comprises placing a target object in a post receiving socket, and wherein securing an object to the plate comprises securing a post to a post receiving socket.
63. The method of claim 62 wherein hammering the target object downward
20 comprises hammering with a sledge hammer or mallet.