



- (51) International Patent Classification:
B23K 37/02 (2006.01) *B23K 31/02* (2006.01)
B23K 37/053 (2006.01) *H05B 6/10* (2006.01)
- (21) International Application Number:
PCT/US2014/045167
- (22) International Filing Date:
1 July 2014 (01.07.2014)
- (25) Filing Language: English
- (26) Publication Language: English
- (30) Priority Data:
13/956,882 1 August 2013 (01.08.2013) US
- (71) Applicant: **ILLINOIS TOOL WORKS INC.** [US/US];
155 Harlem Avenue, Glenview, Illinois 60025 (US).
- (72) Inventors: **SHERILL, Alan Dale**; c/o Illinois Tool
Works Inc., 155 Harlem Avenue, Glenview, Illinois 60025
(US). **BYRNE, James Andrew**; c/o Illinois Tool Works
Inc., 155 Harlem Avenue, Glenview, Illinois 60025 (US).
- (74) Agent: **HAUPTMAN, Benjamin J.**; Lowe Hauptman &
Ham, LLP, 2318 Mill Road, Suite 1400, Alexandria, Vir-
ginia 22314 (US).
- (81) Designated States (unless otherwise indicated, for every
kind of national protection available): AE, AG, AL, AM,
AO, AT, AU, AZ, BA, BB, BG, BH, BN, BR, BW, BY,
BZ, CA, CH, CL, CN, CO, CR, CU, CZ, DE, DK, DM,

DO, DZ, EC, EE, EG, ES, FI, GB, GD, GE, GH, GM, GT,
HN, HR, HU, ID, IL, IN, IR, IS, JP, KE, KG, KN, KP, KR,
KZ, LA, LC, LK, LR, LS, LT, LU, LY, MA, MD, ME,
MG, MK, MN, MW, MX, MY, MZ, NA, NG, NI, NO, NZ,
OM, PA, PE, PG, PH, PL, PT, QA, RO, RS, RU, RW, SA,
SC, SD, SE, SG, SK, SL, SM, ST, SV, SY, TH, TJ, TM,
TN, TR, TT, TZ, UA, UG, US, UZ, VC, VN, ZA, ZM,
ZW.

- (84) Designated States (unless otherwise indicated, for every
kind of regional protection available): ARIPO (BW, GH,
GM, KE, LR, LS, MW, MZ, NA, RW, SD, SL, SZ, TZ,
UG, ZM, ZW), Eurasian (AM, AZ, BY, KG, KZ, RU, TJ,
TM), European (AL, AT, BE, BG, CH, CY, CZ, DE, DK,
EE, ES, FI, FR, GB, GR, HR, HU, IE, IS, IT, LT, LU, LV,
MC, MK, MT, NL, NO, PL, PT, RO, RS, SE, SI, SK, SM,
TR), OAPI (BF, BJ, CF, CG, CI, CM, GA, GN, GQ, GW,
KM, ML, MR, NE, SN, TD, TG).

Declarations under Rule 4.17:

- as to applicant's entitlement to apply for and be granted a patent (Rule 4.17(ii))
- as to the applicant's entitlement to claim the priority of the earlier application (Rule 4.17(iii))

Published:

- with international search report (Art. 21(3))

(54) Title: SYSTEM, DEVICE, AND METHODS FOR HEATING AN INSIDE WALL OF A PIPE OR A VESSEL WITH A HEATING MEANS AND A MOVABLE MECHANICAL DEVICE

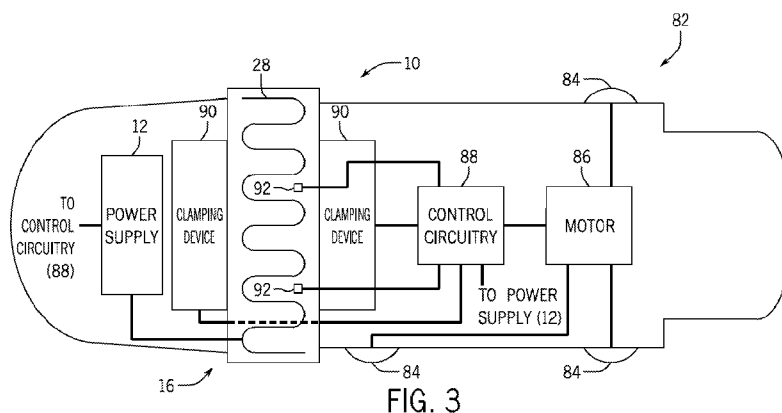

(57) Abstract: A system, a device, and a method for heating an inside wall of a pipe or a vessel. In one example, a system is for heating an inside wall of a pipe, a vessel, or some combination thereof. The system includes a movable mechanical device (82) configured to be positioned at least partially within the pipe, the vessel, or some combination thereof. The movable mechanical device (82) is configured to be moved using control circuitry (88). The system also includes a heating device (16) coupled to the movable mechanical device (82) and configured to be positioned at least partially within the pipe, the vessel, or some combination thereof. The heating device (16) is also configured to heat the inside wall of the pipe, the vessel, or some combination thereof.

WO 2015/017072 A1

SYSTEM, DEVICE, AND METHODS FOR HEATING AN INSIDE WALL OF A PIPE OR A VESSEL
WITH A HEATING MEANS AND A MOVABLE MECHNAICAL DEVICE

BACKGROUND

[0001] The invention relates generally to induction heating and, more specifically, to systems, devices, and methods for heating an inside wall of a pipe or a vessel.

[0002] Welding is a process that has increasingly become utilized in various industries and applications. Such processes may be automated in certain contexts, although a large number of applications continue to exist for manual welding operations. In both cases, such welding operations rely on a variety of types of equipment to ensure the supply of welding consumables (e.g., wire feed, shielding gas, etc.) is provided to the weld in appropriate amounts at the desired time.

[0003] In certain applications, a workpiece may be preheated, thereby removing hydrogen from the workpiece, facilitating a flow of filler material, and improving welding penetration, such as when a material of the workpiece has a high thermal conductivity (e.g., materials such as aluminum, steel, etc.). For example, when welding on a pipe, a heating device may be positioned on the outside of the pipe to preheat the pipe. After being preheated, welding may be performed on the pipe. Unfortunately, the heating device may physically interfere with the welding process, thereby making it more difficult to produce a high quality, continuous, and/or consistent weld. In another example, a workpiece may be preheated using a flame directed toward the portion of the workpiece to be preheated. Unfortunately, the flame may not uniformly heat the workpiece as desired, may induce hydrogen into the welded area, may be time consuming to facilitate, may be labor intensive, may consume fuel, and/or may alter the surface of the workpiece.

BRIEF DESCRIPTION

[0004] In one embodiment, a system is for heating an inside wall of a pipe, a vessel, or some combination thereof. The system includes a movable mechanical device configured to be positioned at least partially within the pipe, the vessel, or

some combination thereof. The movable mechanical device is configured to be moved using control circuitry. The system also includes a heating device coupled to the movable mechanical device and configured to be positioned at least partially within the pipe, the vessel, or some combination thereof. The heating device is also configured to heat the inside wall of the pipe, the vessel, or some combination thereof.

[0005] In another embodiment, a method is for heating an inside wall of a pipe, a vessel, or some combination thereof. The method includes disposing a heating device within the pipe, the vessel, or some combination thereof. The heating device is mechanically movable using control circuitry. The method also includes energizing the heating device to heat the inside wall of the pipe, the vessel, or some combination thereof.

[0006] In a further embodiment, a device is for heating an inside wall of a pipe, a vessel, or some combination thereof. The device includes a heating device configured to be positioned at least partially within the pipe, the vessel, or some combination thereof. The device is also configured to heat the inside wall of the pipe, the vessel, or some combination thereof. The device also includes a mechanism configured to position the heating device at least partially within the pipe, the vessel, or some combination thereof. The mechanism is configured to be moved using control circuitry.

DRAWINGS

[0007] These and other features, aspects, and advantages of the present invention will become better understood when the following detailed description is read with reference to the accompanying drawings in which like characters represent like parts throughout the drawings, wherein:

[0008] FIG. 1 is a block diagram of an embodiment of a heating system having a power supply and a heating device, in accordance with aspects of the present disclosure;

[0009] FIG. 2 is a perspective view of an embodiment of a workpiece having a joint to be welded, in accordance with aspects of the present disclosure;

[0010] FIG. 3 is a block diagram of an embodiment of a movable mechanical device integrated with a heating system to facilitate heating of an inside wall of a workpiece, in accordance with aspects of the present disclosure; and

[0011] FIG. 4 is a flow chart of an embodiment of a method for heating an inside wall of a workpiece, in accordance with aspects of the present disclosure.

DETAILED DESCRIPTION

[0012] Turning now to the drawings, FIG. 1 illustrates an embodiment of a heating system 10 (e.g., induction heating system) having a power supply and a heating device. In certain embodiments, the heating system 10 may be used to heat (e.g., preheat, postheat, etc.) a workpiece (e.g., an inside wall of a pipe) to improve a finished weld. As illustrated, the heating system 10 includes a power supply 12 that provides (e.g., supplies) a power output 14 to a heating device 16 (e.g., induction coil, induction heating head, resistance heater, infrared heater, heater bars, flame, star heater, rosebud, etc.). The power output 14 may be a high frequency alternating current power output designed to produce a field.

[0013] Upon receiving the power output 14, the heating device 16 produces a field 24 (e.g., electromagnetic field) as the power output 14 flows through a coil element 28. The field 24 may be used to heat a workpiece by induction heating. As will be appreciated by those skilled in the art, induction heating is a phenomenon that occurs when conductive materials are within a changing magnetic or electromagnetic field.

[0014] Embodiments of the power supply 12 may include power conversion circuitry 30 configured to receive a power input 32 (e.g., alternating current) from a power source 34. As illustrated, the power source 34 may supply an alternating current to the power supply 12 as single- or multi-phase input. Alternatively, the power source 34 may provide a direct current power input 32, and the power conversion circuitry 30 may include an inverter or any suitable power conversion

circuitry to produce an alternating current. The power input 32 may have a first frequency (e.g., 60 Hz). The power conversion circuitry 30 may increase the frequency of the power input 32 to produce an alternating current output 36 of a second frequency (e.g., 20 kHz). For example, the power conversion circuitry 30 may increase the frequency of the power input 32 so that the alternating current output 36 is between approximately 5 kHz to 60 kHz, approximately 7 kHz to 50 kHz, or approximately 400 Hz to 50 kHz. The alternating current output 36 may have any suitable waveform, such as a sine wave, a square wave, a triangle wave, a sawtooth wave, and so forth.

[0015] A transformer 38 between the power conversion circuitry 30 and a coil assembly 40 transmits the power of the alternating current output 36 to the power output 14, and may change the voltage and the current transmitted to the coil element 28. The transformer 38 may also step up the voltage or the current and/or inversely step down the voltage or the current. For example, a 4:1 transformer may step down the voltage by a factor of 4 and increase the current by a factor of 4, while negligibly affecting the power transmitted. In certain embodiments, an impedance matching transformer may be configured to increase the efficiency of power transmitted to the power output 14 by reducing losses due to mismatched impedance of the power supply 12 relative to the coil assembly 40. The transformer 38 may be used to increase a magnitude of the current change within the coil assembly 40 due to the alternating current, and thus increase the magnetic field produced by the coil element 28 and, thereby, the heat produced by the heating device 16. The transformer 38 is also used to better match the impedance of the coil assembly 40 to the power supply 12. As may be appreciated, certain embodiments may not include the transformer 38.

[0016] Control circuitry 42 within the power supply 12 provides for control of the heating system 10. The control circuitry 42 is coupled to the coil assembly 40 via a control line 44. In some embodiments, the heating device 16 may be configured for hand-held operation. For example, the coil assembly 40 may include a handle and may be readily portable by an operator without the use of additional equipment. The coil assembly 40 may have a trigger 46, switch, button, or other input device configured to transmit a signal via the control line 44 to the control circuitry 42. The

control circuitry 42 controls the activation of heating device 16 through the control line 44 and/or through the control line 48 coupling the power conversion circuitry 30 to the control circuitry 42. For example, actuation of the trigger 46 initiates production of the field 24 by controlling the current in the power supply 12 or heating device 16. In some embodiments, the control circuitry 42 directs power output through the heating device 16 to produce the field 24 while the trigger 46 is actuated. In other embodiments, the trigger 46 actuates a momentary contact switch, and the field 24 is produced for a predetermined time after actuation of the trigger. For example, trigger 46 actuation may produce the field 24 for approximately up to 1, 2, 3, 4, 5, 10, or 15 seconds. Thus, the heating device 16 may be used for heating a workpiece. For example, the heating device 16 may raise the temperature of the workpiece by 25, 50, 100, 150, 200, 250, 300, 400, 500 degrees Celsius or more. In certain embodiments, the power supply 12 may include temperature detecting devices configured to detect one or more temperatures. The temperature detecting devices may provide temperature indications to the control circuitry 42. Moreover, the temperature indications may be used to control the temperature of the heating device 16. Accordingly, the control circuitry 42 may be configured to adjust an output provided to the heating device 16 based at least partly on a detected temperature.

[0017] The control circuitry 42 may be powered at least in part by the power conversion circuitry 30. The control circuitry 42 adjusts the frequency, current, voltage, power, duration, and other operating parameters of the alternating current output 36 produced by the power conversion circuitry 30. An operator interface 50 of the power supply 12 enables operator input 52 for adjusting the settings of the power conversion circuitry 30. For example, the operator interface 50 may be configured to permit the operator input 52 of at least one heating parameter. The operator interface 50 may have a plurality of controls (e.g., knobs, dials, buttons, switches, and sliders) to receive operator input 52. In addition, the operator interface 50 produces outputs 54 to alert the operator to the condition and state of the power supply 12 and the heating device 16. For example, the operator interface 50 includes a display to indicate the power, current, and/or voltage of the power input 32, the alternating current output 36, or the power output 14. The operator interface 50 may also

indicate a duration of a produced field, the temperature of the heating device 16, whether the coil assembly 40 is coupled to the power supply 12, and/or whether a cooling system 58 is operational, among other properties pertaining to the status and operation of the power supply 12 and the heating device 16. The operator interface 50 may be on the power supply 12 or remotely coupled to the power supply 12. For example, the operator interface 50 may be a remote device coupled to the power supply 12 by a wired or wireless connection.

[0018] The power supply 12 may have the cooling system 58 to regulate operation of the transformer 38 and/or the heating device 16. For example, the cooling system 58 cools the heating device 16 to provide for sustained production of a field 24 and/or a high current through the coil element 28. The control circuitry 42 controls the cooling system 58 via the control line 56. The cooling system 58 directs a cooling fluid (e.g., air, water, etc.) to the heating device 16 through a first cooling conduit 60. During production of the field 24, the heating device 16 may become warm due to the current passing through the coil element 28 and/or due to radiation from the induction heated workpiece. The first cooling conduit 60 may be removably coupled to the coil assembly 40 and induction coil by a coupling 62. The power output 14 and first cooling conduit 60 together may be part of an input conduit 64 that may be removably coupled by the coupling 62 to the coil assembly 40. For example, the input conduit 64 includes a water cooled conductive wire (e.g., Litz wire) to transmit the power output 14 to the heating device 16. As may be appreciated, in certain embodiments, the power supply 12 may not include a cooling system 58 and/or may be cooled by air flow over the components of the power supply 12.

[0019] The control line 44 may also be a part of the input conduit 64 removably coupled to the coil assembly 40. Alternatively, the power output 14, control line 44, and first cooling conduit 60 may be separately coupled to the heating device 16 and coil assembly 40. The cooling system 58 may also direct a cooling fluid to the transformer 38 through a second cooling conduit 66. The cooling fluid controlled by the cooling system 58 may include air, water, refrigerant (e.g., ammonia, R-134a, R-410a), and so forth. The cooling system 58 circulates the cooling fluid through the heating device 16 and transformer 38 as shown by the return arrows of the first and

second fluid conduits 60 and 66. The cooling system 58 may cool both the heating device 16 and the transformer 38 through a common cooling loop that includes the first fluid conduit 60 and second fluid conduit 66. Alternatively, each may be cooled separately through the respective first and second cooling conduits 60, 66. The control circuitry 42 may control the heating system 10 so that the heating device 16 will not produce a field 24 unless the cooling system 58 is cooling the heating device 16 and/or the transformer 38.

[0020] The control circuitry 42 may enable the heating system 10 to be programmed. Through the operator interface 50, the operator may adjust the heating parameters of the power supply 12 to change the field 24 produced by the heating device 16. Heating parameters may include a current flowing through the coil element 28, a voltage across the coil element 28, a power used by the coil element 28, a frequency of the power output 14, a duration of the field 24, and a temperature of the workpiece. In some embodiments, the control circuitry 42 has a memory for storing computer readable instructions and a processor for processing the instructions. For example, using the operator inputs 52, an operator may input desired heating parameters. The heating parameters may be stored in memory. Upon actuation of the trigger 46 (e.g., manually, mechanically, automatically), the control circuitry 42 causes the heating device 16 to produce a field 24 of a predetermined frequency and intensity for a predetermined time to heat a workpiece.

[0021] By using the heating system 10, a welding operator may heat (e.g., preheat) a joint to be welded. Furthermore, at least a portion of the heating system 10 may be positioned within a workpiece (e.g., a pipe, a vessel) to heat an inside wall of the workpiece, thereby not physically interfering with welding performed on an outside wall of the workpiece. Thus, a high quality, continuous, and/or consistent weld may be produced. Furthermore, the heating system 10 may uniformly heat the workpiece as desired, may be efficient, may be automatic (e.g., done with little or no human intervention), and/or may not alter the surface of the workpiece.

[0022] FIG. 2 is a perspective view of an embodiment of a workpiece 70 having a joint to be welded. The workpiece 70 may be any suitable workpiece, such as a pipe

or a vessel. As used herein, “vessel” may refer to a ship, a boat, or any suitable hollow container having an inside wall and an outside wall. As illustrated, the workpiece 70 includes an outside wall 72 and an inside wall 74. Furthermore, the workpiece 70 includes a joint 76 between a first segment 78 and a second segment 80. In certain embodiments, the joint 76 may be welded to secure the first segment 78 to the second segment 80.

[0023] The heating system 10 may be positioned at least partially within the workpiece 70 (e.g., manually, automatically) such that the heating device 16 provides heat to the inside wall 74 of the workpiece 70 to heat the joint 76 area (e.g., for preheating the joint 76 area prior to performing a weld along the joint 76). By position the heating system 10 at least partially inside the workpiece 70, welding along the joint 76, or at any other portion of the outside wall 72, may be performed on the outside of the workpiece 70 without the heating system 10 physically interfering with (e.g., blocking) the welding operation.

[0024] In the illustrated embodiment, the heating system 10 is coupled to and/or integrated with a movable mechanical device 82. Accordingly, the movable mechanical device 82 may be used to position the heating device 16 within, or at least partially within, the workpiece 70. Furthermore, the movable mechanical device 82 may itself be positioned within, or at least partially within, the workpiece 70. Moreover, the movable mechanical device 82 may be used to position the heating device 16 adjacent to the joint 76 to enable heating of the joint 76. In certain embodiments, the movable mechanical device 82 may be configured to move within the workpiece 70 to position the heating device 16 adjacent to the joint 76. For example, the movable mechanical device 82 may manually, or automatically, move within the workpiece 70 to a suitable position. In some embodiments, the movable mechanical device 82 may include a pipeline pig (e.g., a mechanical device configured to move through pipe), an internal pipe clamp, a pneumatic internal pipe clamp, or any suitable mechanical device, such as a tractor riding on a track, a tractor with magnetic wheels, and so forth. Thus, the movable mechanical device 82 may simplify placing the heating device 16 adjacent to a portion of the workpiece 70 to be heated. Moreover, the heating device 16 is positioned adjacent to the inside wall 74

of the workpiece 70 so that there is no physical interference with welding performed on the outside wall 72 of the workpiece 70.

[0025] FIG. 3 is a block diagram of an embodiment of the movable mechanical device 82 integrated with the heating system 10 to facilitate heating of the inside wall 74 of the workpiece 70. As illustrated, the movable mechanical device 82 includes multiple wheels 84 rotatable to move the movable mechanical device 82 within the workpiece 70, such as for moving the movable mechanical device 82 through a pipe or within a vessel. The movable mechanical device 82 also includes a motor 86 (e.g., or another driving device) configured to drive the wheels 84 to rotate (e.g., to move the movable mechanical device 82). Moreover, the movable mechanical device 82 includes control circuitry 88 configured to control motion, position, and/or operation of the movable mechanical device 82. Furthermore, the control circuitry 88 may be configured to control operation of one or more clamping devices 90 installed on the movable mechanical device 82. In certain embodiments, the control circuitry 88 may include electronic controls, hydraulic controls, pneumatic controls, and so forth. The clamping devices 90 are used to hold two materials adjacent to one another while a welding operation is being performed on the two materials, such as the first segment 78 and the second segment 80 of the workpiece 70. In certain embodiments, the control circuitry 88 may communicate with the control circuitry 42 of the power supply 12 to control the operation of the heating system 10. In other embodiments, the control circuitry 42 of the power supply 12 may control operation of the heating system 10 without interaction with the control circuitry 88. Moreover, in some embodiments, the control circuitry 42 of the power supply 12 may be configured to control operation of the movable mechanical device 82 in place of the control circuitry 88.

[0026] When heating is desired, the control circuitry 42 and/or the control circuitry 88 may control the heating system 10 to apply heat to the workpiece 70 using the coil element 28 of the heating device 16 and/or to control the heating device 16 based at least partly on a detected temperature. In certain embodiments, the heating device 16 of the heating system 10 may be configured to touch the inside wall 74 of the workpiece 70 to heat the workpiece 70 by conduction. Moreover, in other

embodiments, the heating device 16 may be configured to heat the inside wall 74 of the workpiece 70 by radiation from the heating device 16. Furthermore, in some embodiments, the heating device 16 may be configured to heat the workpiece 70 via convection (e.g., using a flame or a resistance heating device). For example, the movable mechanical device 82 may be a similar size to the workpiece 70 and the heating device 16 may be disposed on the movable mechanical device 82 to touch the inside wall 74. As another example, the movable mechanical device 82 may be smaller than the workpiece 70, and the heating device 16 may extend from the movable mechanical device 82 to touch, or be positioned adjacent to, the inside wall 74. As a further example, the movable mechanical device 82 may be smaller than the workpiece 70, and the movable mechanical device 82 may extend, such as via extensions from the wheels 84, to position the heating device 16 to touch, or be positioned adjacent to, the inside wall 74. Thus, the size of the movable mechanical device 82 may not directly correspond to the size of the workpiece 70.

[0027] As illustrated, one or more temperature detecting devices 92 may be positioned by the movable mechanical device 82 to detect a temperature provided by the heating system 10. The temperature detecting devices 92 may be any suitable temperature detecting device, such as a thermocouple, an infrared detector, a temperature sensor, and so forth. As may be appreciated, the temperature detecting devices 92 may be configured to detect a temperature of the heating device 16, the inside wall 74 of the workpiece 70, the outside wall 72 of the workpiece 70, and so forth. The control circuitry 88 and/or the control circuitry 42 may monitor the temperature detected by the temperature detecting devices 92 and may control the heating system 10 to a desired temperature based on the detected temperature. Thus, the control circuitry 88 may control the heating system 10 to a desired temperature, thereby enabling the heating system 10 to be dynamically controlled.

[0028] FIG. 4 is a flow chart of an embodiment of a method 100 for heating an inside wall (e.g., inside wall 74) of a workpiece (e.g., workpiece 70, a pipe, a vessel). A heating device (e.g., heating device 16) is disposed within the workpiece (block 102). In certain embodiments, the heating device is mechanically movable. The heating device is positioned adjacent to a joint (e.g., joint 76) to be welded (block

104). Moreover, the heating device is energized to heat the inside wall of the workpiece (block 106). In addition, the joint may be welded at an outside wall (e.g., outside wall 72) of the workpiece (block 108). In certain embodiments, a joint may be welded on an inside wall.

[0029] By using the heating system 10, a welding operator may heat (e.g., preheat) a joint to be welded. Furthermore, the heating system 10 may be positioned within a workpiece (e.g., a pipe, a vessel) to heat the inside wall of the workpiece, thereby not physically interfering with welding performed on the outside wall of the workpiece. Thus, a high quality, continuous, and/or consistent weld may be produced. Furthermore, the heating system 10 may uniformly heat the workpiece as desired, may be efficient, may be automatic (e.g., done with little or no human intervention), and/or may not alter the surface of the workpiece.

[0030] While only certain features of the invention have been illustrated and described herein, many modifications and changes will occur to those skilled in the art. It is, therefore, to be understood that the appended claims are intended to cover all such modifications and changes as fall within the true spirit of the invention.

CLAIMS:

1. A system for heating an inside wall of a pipe, a vessel, or some combination thereof, comprising:

a movable mechanical device configured to be positioned at least partially within the pipe, the vessel, or some combination thereof, wherein the movable mechanical device is configured to be moved using control circuitry; and

a heating device coupled to the movable mechanical device and configured to be positioned at least partially within the pipe, the vessel, or some combination thereof, and to heat the inside wall of the pipe, the vessel, or some combination thereof.

2. The system of claim 1, wherein the movable mechanical device comprises a pipeline pig.

3. The system of claim 1, wherein the movable mechanical device comprises an internal pipe clamp.

4. The system of claim 3, wherein the internal pipe clamp comprises a pneumatic internal pipe clamp.

5. The system of claim 1, wherein the movable mechanical device is configured to be manually adjusted using the control circuitry to control a position of the movable mechanical device.

6. The system of claim 1, wherein the movable mechanical device comprises a motor configured to move the movable mechanical device.

7. The system of claim 1, wherein the heating device comprises an induction coil.

8. The system of claim 1, wherein the heating device comprises an induction heating head, a flame, or some combination thereof.

9. The system of claim 1, wherein the heating device is configured to touch the inside wall of the pipe, the vessel, or some combination thereof.

10. The system of claim 1, wherein the heating device is configured to heat the inside wall of the pipe, the vessel, or some combination thereof by radiation or convection from the heating device.

11. The system of claim 1, comprising a temperature detection device configured to detect a temperature of at least one of the heating device, the inside wall, and an outside wall of the pipe, the vessel, or some combination thereof.

12. The system of claim 11, wherein the temperature detection device comprises a thermocouple, an infrared detector, or some combination thereof.

13. The system of claim 11, comprising a power supply configured to power the heating device, wherein the power supply is configured to adjust an output provided to the heating device based at least partly on the detected temperature.

14. A method for heating an inside wall of a pipe, a vessel, or some combination thereof, comprising:

disposing a heating device within the pipe, the vessel, or some combination thereof, wherein the heating device is mechanically movable using control circuitry; and

energizing the heating device to heat the inside wall of the pipe, the vessel, or some combination thereof.

15. The method of claim 14, comprising positioning the heating device within the pipe, the vessel, or some combination thereof, adjacent to a joint to be welded.

16. The method of claim 15, comprising welding the joint at an outside wall of the pipe, the vessel, or some combination thereof.

17. The method of claim 14, wherein the heating device comprises an induction heating device.

18. A device for heating an inside wall of a pipe, a vessel, or some combination thereof, comprising:

a heating device configured to be positioned at least partially within the pipe, the vessel, or some combination thereof, and to heat the inside wall of the pipe, the vessel, or some combination thereof; and

a mechanism configured to position the heating device at least partially within the pipe, the vessel, or some combination thereof, wherein the mechanism is configured to be moved using control circuitry.

19. The device of claim 18, wherein the heating device comprises an induction coil.

20. The device of claim 18, wherein the heating device comprises an induction heating head, a flame, or some combination thereof.

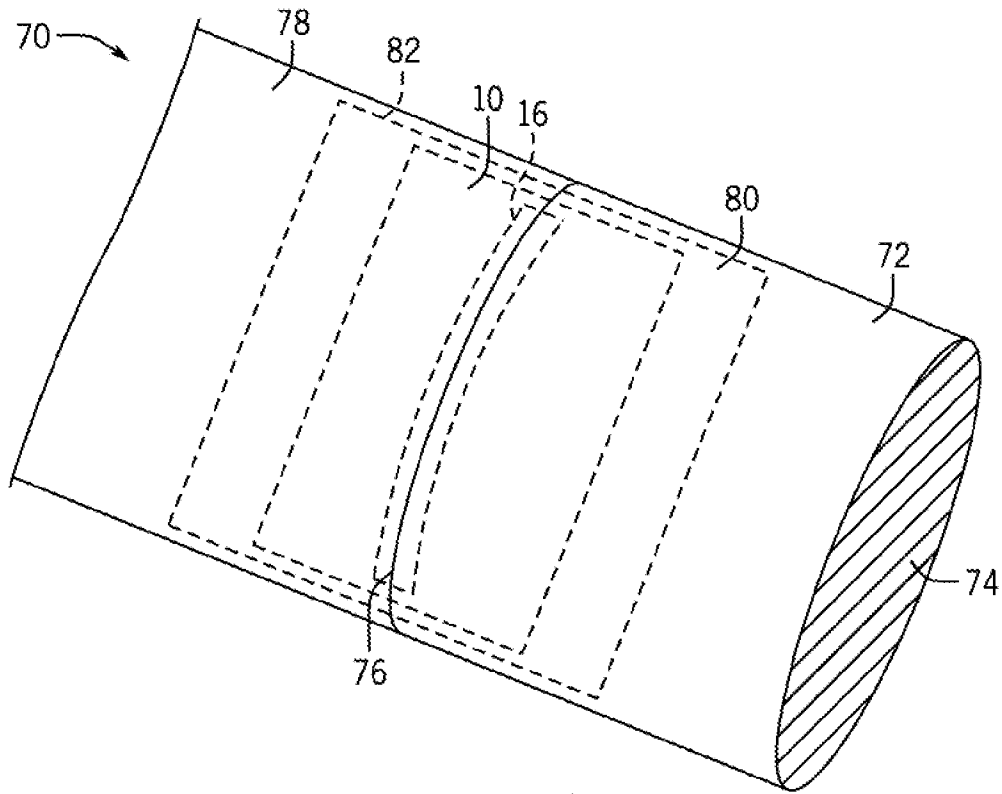

FIG. 2

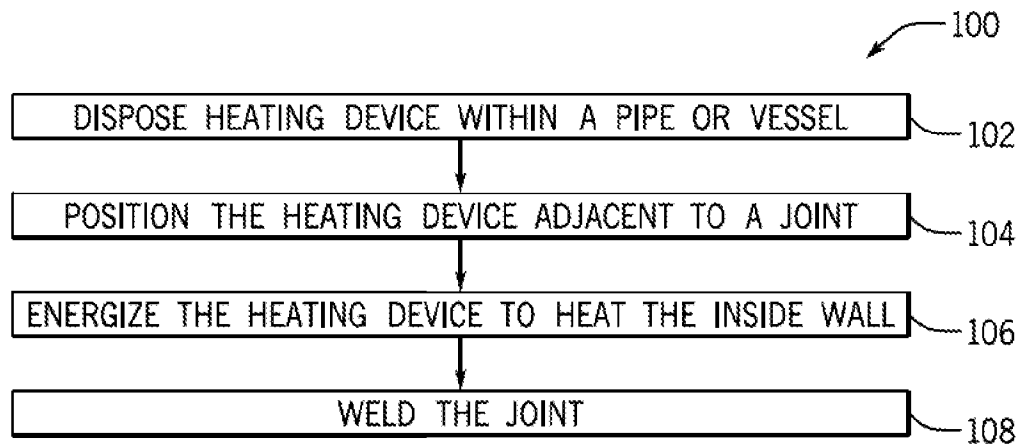

FIG. 4

INTERNATIONAL SEARCH REPORT

International application No
PCT/US2014/045167

A. CLASSIFICATION OF SUBJECT MATTER
INV. B23K37/02 B23K37/053 B23K31/02 H05B6/10
ADD.
According to International Patent Classification (IPC) or to both national classification and IPC

B. FIELDS SEARCHED
Minimum documentation searched (classification system followed by classification symbols)
B23K H05B

Documentation searched other than minimum documentation to the extent that such documents are included in the fields searched

Electronic data base consulted during the international search (name of data base and, where practicable, search terms used)
EPO-Internal, WPI Data

C. DOCUMENTS CONSIDERED TO BE RELEVANT

Category*	Citation of document, with indication, where appropriate, of the relevant passages	Relevant to claim No.
X	EP 0 112 752 A1 (KLEY FRANCE) 4 July 1984 (1984-07-04)	1,3,5,9, 10, 14-16,18
Y	page 7, line 15 - page 8, line 6 page 10, line 31 - page 11, line 38; figures	4,6,7, 11-13, 17,19
Y	----- US 6 119 916 A (C. J. ANDERSON ET AL) 19 September 2000 (2000-09-19) column 8, line 63 - column 9, line 37; figures	4,6
Y	----- JP H06 281057 A (CHIYODA CORP) 7 October 1994 (1994-10-07) abstract; figures	7,17,19
	----- -/--	

Further documents are listed in the continuation of Box C.

See patent family annex.

* Special categories of cited documents :

"A" document defining the general state of the art which is not considered to be of particular relevance

"E" earlier application or patent but published on or after the international filing date

"L" document which may throw doubts on priority claim(s) or which is cited to establish the publication date of another citation or other special reason (as specified)

"O" document referring to an oral disclosure, use, exhibition or other means

"P" document published prior to the international filing date but later than the priority date claimed

"T" later document published after the international filing date or priority date and not in conflict with the application but cited to understand the principle or theory underlying the invention

"X" document of particular relevance; the claimed invention cannot be considered novel or cannot be considered to involve an inventive step when the document is taken alone

"Y" document of particular relevance; the claimed invention cannot be considered to involve an inventive step when the document is combined with one or more other such documents, such combination being obvious to a person skilled in the art

"&" document member of the same patent family

Date of the actual completion of the international search 29 October 2014	Date of mailing of the international search report 07/11/2014
---	---

Name and mailing address of the ISA/ European Patent Office, P.B. 5818 Patentlaan 2 NL - 2280 HV Rijswijk Tel. (+31-70) 340-2040, Fax: (+31-70) 340-3016	Authorized officer Jeggy, Thierry
--	---

INTERNATIONAL SEARCH REPORT

International application No
PCT/US2014/045167

C(Continuation). DOCUMENTS CONSIDERED TO BE RELEVANT		
Category*	Citation of document, with indication, where appropriate, of the relevant passages	Relevant to claim No.
Y	GB 2 475 574 A (RAPID HEAT SYSTEMS LTD) 25 May 2011 (2011-05-25) page 6, line 19 - page 7, line 9; figures -----	11-13
X	US 2013/092665 A1 (T. HASSEL ET AL) 18 April 2013 (2013-04-18) paragraphs [0023], [0029], [0037]; figures -----	1,2,5,7, 10,14-19 8,20
Y	JP H08 276214 A (NIPPON KOKAN KK) 22 October 1996 (1996-10-22) abstract; figures -----	8,20
X	JP 2009 220179 A (TOSHIBA CORP) 1 October 2009 (2009-10-01) abstract; figures paragraphs [0041] - [0043] -----	1,5,10, 14-16,18

INTERNATIONAL SEARCH REPORT

Information on patent family members

International application No PCT/US2014/045167

Patent document cited in search report	Publication date	Patent family member(s)	Publication date
EP 0112752	A1	04-07-1984	EP 0112752 A1
			FR 2537466 A1
US 6119916	A	19-09-2000	AU 6321699 A
			CA 2251307 A1
			US 6119916 A
			WO 0024546 A1
JP H06281057	A	07-10-1994	NONE
GB 2475574	A	25-05-2011	EP 2378835 A2
			GB 2475574 A
			US 2011253677 A1
US 2013092665	A1	18-04-2013	US 2013092665 A1
			WO 2013055600 A1
JP H08276214	A	22-10-1996	JP 3134706 B2
			JP H08276214 A
JP 2009220179	A	01-10-2009	NONE