

J. H. ROBERTSON.

ART OF EXTRACTING METALS ELECTROLYTICALLY.

APPLICATION FILED JUNE 20, 1908. RENEWED MAY 5, 1910.

978,211.

Patented Dec. 13, 1910.

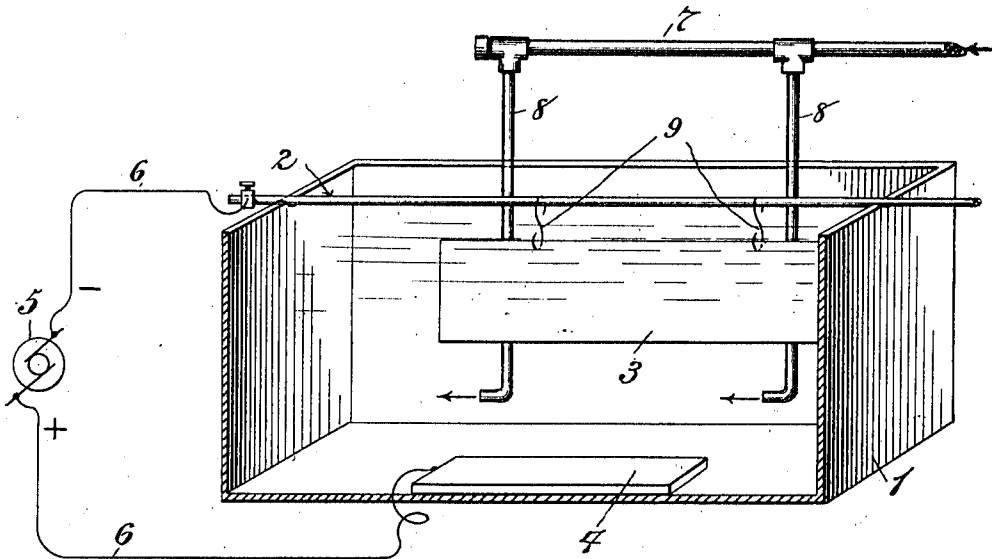

Witnesses:
Edward Dowland
W. F. Neating

Inventor
James Hart Robertson
By his Attorney
Charles J. Kintner

UNITED STATES PATENT OFFICE.

JAMES HART ROBERTSON, OF NEW YORK, N. Y.

ART OF EXTRACTING METALS ELECTROLYTICALLY.

978,211.

Specification of Letters Patent.

Patented Dec. 13, 1910.

Application filed June 20, 1908, Serial No. 439,562. Renewed May 5, 1910. Serial No. 559,485.

To all whom it may concern:

Be it known that I, JAMES HART ROBERTSON, a citizen of the United States, and resident of New York, borough of Manhattan, county and State of New York, have made a new and useful Invention in the Art of Extracting Metals Electrolytically, of which the following is a specification.

My invention is directed particularly to a novel method of extracting gold and other precious metals from their ores after they have been reduced to a very minute or finely powdered state, and it has for its objects, first, to provide a method of effecting this result in as simple, efficient and inexpensive a manner as possible; second, to devise a method of extracting gold when found in other than a metallic state (chlorids, for instance) by the agency of electrolysis and in such manner that the gold is deposited on the cathode of the apparatus used in practicing said method.

My invention will be fully understood by referring to the accompanying drawing which is a sectional perspective and part diagrammatic view of an apparatus designed to practice the method hereinafter described and claimed.

1 represents a water-tight vat or separating chamber and 2 a rod, preferably of copper or other good conducting material, resting upon the opposite ends thereof.

3 is a metallic cathode of some light sheet metal, such as copper foil, and preferably corrugated so as to give it increased conducting capacity and depositing surface, said cathode being suspended directly from the rod 2 by two or more conductors, as shown.

4 is the anode of sheet or block form made preferably of some good conducting material, not readily disintegrated by an electrical current, as hard carbon.

5 is the dynamo electric machine or equivalent source of electrical energy and 6, 6, conductors running therefrom to the anode and cathode respectively, as shown.

7 is a pipe or tube adapted to be connected to a source of heated vapor or gas, as steam or air, and 8, 8, are branches thereof extending downward to points within the vat and beneath the cathode 3 and turned laterally in the plane of the anode and cathode at their lower ends as shown.

The electrolyte which is illustrated in the drawing as submerging the anode and cath-

ode when used in the process of extracting gold may be cyanid of potassium or of any other such equivalent materials as are used in the art of electrolytic methods of extracting valuable metals and the anode and cathode may be located in the body of the electrolyte in any preferred manner, or may be of any preferred material and construction or shape, such matters coming well within the skill of those versed in the electrolytic art generally, the essential feature being that they shall be so located as to readily remove the cathode for the purpose of extracting the gold therefrom by fusion in the usual way. The cathode is illustrated in the drawing as being suspended from the conducting rod 2 by good conducting metallic hooks 9, 9.

The ore to be treated is first pulverized or ground to a fine powder and gradually fed into the electrolyte which is kept in an agitated condition or circulation by steam, hot air or gas issuing from the source of supply, not shown, through the pipes 7 and 8. In view of the fact that a relatively large amount of the powdered ore will remain in suspension while the liquid is in motion when it is placed in the vat and is simultaneously subjected to the action of electricity, motion and heat until the major part of the metal is deposited on the cathode 3, it will be appreciated that I am enabled by the use of this apparatus and by the practice of this method to speedily extract pure metals from electrolytes of this nature. I have ascertained that by the use of such an apparatus I am enabled to effect such a circulation of the ore through the electrolyte and to simultaneously so heat the same as to effect a very rapid extraction of the metal.

I have ascertained in the practice of the hereinbefore described method that the electrolyte should be heated to temperatures varying from 150° to 212° F., inasmuch as such heating controls the liberation of the gold resolvent, and these temperatures will differ for different ores. By the use of heat in this manner the liberation of the gold resolvent is controlled in such a way that there is no sensible loss of the resolvent, and in the application of heat simultaneously with proper agitation and by simultaneously subjecting the electrolyte to electrical currents I am enabled to obtain the best possible results in the separation of gold and other precious metals from electrolytes as thus treated.

It will be understood, of course, that in the practice of this method and the use of this apparatus the sufficiency of heat and the pressure of the hot air, gas or steam will be determined by the user during the extraction of metals in accordance with the nature of the ore with which the apparatus is to be used and having once determined the amount of such heat and pressure for any definite ore or saturated electrolyte the regulation thereof will afterward be a fixed factor for that particular ore.

In the practice of this method and in the use of this apparatus in extracting gold the salts thereof that may be found in the ore are dissolved and deposited on the cathode by the simultaneous action of heat, agitation and electrical energy.

The microscopic particles of the gold in the ore are dissolved in the electrolyte during the process and reduced by a deposition on the cathode. After the process has been continued for several hours, depending upon the nature of the electrolyte and the quality of the ore to be operated upon, it is discontinued and the electrolyte in a quiet or undisturbed condition is allowed to settle, so that all of the solid matter held in suspension falls to the bottom and the liquid may be siphoned off into another vat, when the electrodes and steam pipes may be lifted out, leaving said vat in condition for the next batch of material to be treated. The electrode upon which the gold is deposited is then subjected to sufficient heat to fuse it and the gold is separated therefrom in the usual manner. It will be appreciated also that inasmuch as varying voltages of electrical energy may often be required during the use of this process, dependent upon the particular quality of the powdered ore to be separated, the exciting dynamo to be used

should be so constructed or arranged as to allow a large range in E. M. F., while the amperage capacity thereof should not be materially affected. It will also be apparent that any preferred source of heated vapor or gas, or combined heated vapors or gases, may be used and with varying pressures, these matters readily suggesting themselves to those versed in the chemical art of electrolytic separation of metals.

Having thus described my invention what I claim and desire to secure by Letters Patent of the United States is—

1. A method of extracting metals which consists in simultaneously subjecting the powdered ore thereof while in suspension in an electrolyte to the combined action of a heated vapor or gas while in motion, and an electrical current.

2. A method of extracting metals which consists in simultaneously subjecting the powdered ore thereof while in suspension in an electrolyte to the agitating effect of a heated vapor or gas and in simultaneously effecting the deposition of the metal upon a fusible electrode.

3. A method of extracting metals which consists in simultaneously subjecting the powdered ore thereof while in suspension in an electrolyte to the agitating effect of a heated vapor or gas and in simultaneously effecting the deposition of the metal upon an electrode capable of being disintegrated by heat.

In testimony whereof I have signed my name to this specification in the presence of two subscribing witnesses.

JAMES HART ROBERTSON.

Witnesses:

C. J. KINTNER,
M. F. KEATING.