

May 9, 1933.

M. C. NIXON ET AL

1,908,530

BED OR ATTACHMENT THEREFOR

Original Filed May 31, 1929

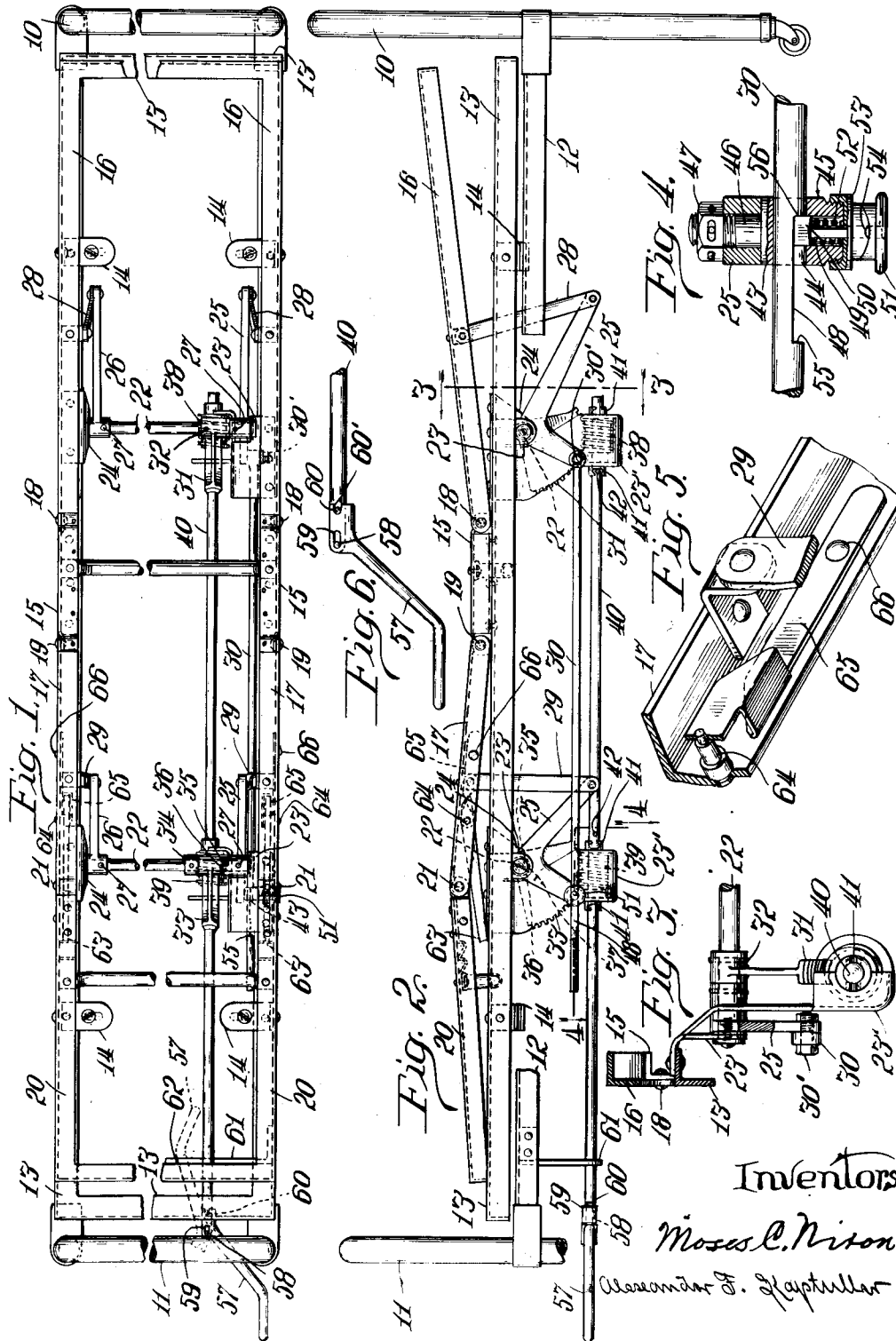

Inventors
Moses C. Nixon
Alexander S. Kapteller

UNITED STATES PATENT OFFICE

MOSES C. NIXON AND ALEXANDER F. KAPTULLER, OF CHICAGO, ILLINOIS; SAID
KAPTULLER ASSIGNOR TO SAID NIXON

BED OR ATTACHMENT THEREFOR

Application filed May 31, 1929, Serial No. 367,328. Renewed April 18, 1930.

The invention relates to beds, particularly to such structures adapted for use by invalids, which comprise pivotally supported sections, which are movable into various positions relative to a central or seat section; and among the objects of the present invention is to provide improved operating mechanism including a rotatable member or shaft for moving the pivoted sections into different positions; to provide improved crank means for driving said shaft, so arranged that the crank is swingable either into its operative position or an out-of-the-way position.

The invention consists in the novel construction, arrangements and devices to be hereinafter described and claimed for carrying out the above stated objects and such other objects as will appear from the following description taken in connection with the accompanying drawing in which:

Fig. 1 is a plan view of a structure employing the principles of the invention, certain parts being broken out.

Fig. 2 is a side elevational view of the structure.

Figs. 3 and 4 are sectional views on an enlarged scale taken on lines 3—3 and 4—4 of Fig. 2.

Fig. 5 is a perspective view on an enlarged scale of a means for holding one of the braces of the structure in position, and Fig. 6 is a detail view on an enlarged scale of crank means for driving the shaft.

In the drawing similar numerals of reference indicate corresponding parts of the different views, and referring to the same, 10 and 11 denote the head and foot respectively and 12 the side rails of a bed, of which the present invention may be made as a part or as a self-contained independent structure of which 13, preferably of angle bars, forms a base frame adapted to be supported by the side rails of a bed or other suitable structure, and may be secured thereto in any suitable manner, as by fastening devices 14. We wish it to be understood that the term "base frame" as used in the claims may be either a fixed part of a bed or an independent frame.

The sectional frame, preferably of angle bars, includes a supporting section 15 secured

in any suitable manner to the base frame 13, body and thigh supporting sections 16 and 17 pivotally secured at one end to the respective ends of the seat section, as by fastenings 18 and 19, and to the free end of the thigh section is pivotally attached a leg section 20, as by fastenings 21, it being understood that in referring to the body, thigh and leg sections in the claims, the terms member or members may be used in place of section or sections as desired.

The means for raising and lowering the body and thigh sections relative to the seat section will now be described: Each of said means comprises a transverse shaft 22 pivotally mounted at one end in a bearing formed in a depending bracket member 23 (see Fig. 3), and at the other end in a depending bracket 24, the brackets 23 and 24 being carried by the frame 13. A bell-crank 25 is mounted on the shaft 22 adjacent one of its ends, and a lever 26 adjacent the other end thereof; said bell-crank and lever being non-rotatably secured to said shaft, as by a pin 27. One arm of the front bell-crank and lever are each connected by a link 28 to the side members of the body section 16; and one arm of the rear bell-crank and lever are each connected by a link 29 to the side rails of the thigh section 17 and are reversely positioned with respect to said section; that is to say the free ends of the levers 25 and 26 connected with the thigh section 17 extends forwardly from their pivots, whereas the movable end of the thigh section 17 extends rearwardly from its pivots 19, in the opposite or reverse direction. It will be noted that the front ends of the rear bell-crank lever 25 and lever 26 swing upwardly and forwardly toward the pivots 19 of the thigh section 17 as said levers and section swing from lower to elevated or extended position. It is understood of course that the reversed levers may be those connected with the body section 16, in which case both sets of levers will extend toward the foot of the bed, the object being to provide for similarly constructed rotatable means for raising or lowering either supporting section when rotated in the same direction, thereby making parts interchangeable

and reduce cost of production. The other arms of the front and rear bell-cranks are connected by a link 30 as will be presently described. The front shaft 22 has a segmental gear 31 rigidly secured to it, as by pin 32; and the rear shaft 22 has a segmental gear 33 loosely mounted thereon adjacent its mating bell-crank, axial movement of the segmental gear 33 on the shaft being prevented by a fixed collar 34. The adjacent side faces of the hubs of segmental gear 33 and the rear bell-crank have laterally projecting co-engaging lugs 35 and 36 respectively. Said lugs are so constructed and arranged that a substantial gap 37 is present underneath the shaft 22 to permit of counter clock-wise movement of the shaft while the segmental gear remains stationary. Worms 38 and 39 carried in suitable pockets provided in the depending brackets 23' are adapted to mesh with the segmental gears 31 and 33 respectively. A longitudinally extending member or drive shaft 40 projects through each of said worms being both slidable and rotatable with respect thereto. In our construction the worms serve for bearings for the shaft. Each worm is provided with a hub at each end and each end is provided with a T shaped recess 41 adapted to receive a projecting pin 42 carried by the shaft 40. When the shaft 40 is in the position shown in Fig. 2 the pin 42 carried by the front end of the shaft is positioned within the recess 41 of the worm 38, and when so positioned the rotation of the shaft will rotate the worm with it, whereby the segmental gear 31 may be moved either in a clock-wise or counter clock-wise direction. Upon sliding the shaft 40 rearwardly the front pin is withdrawn from its mating recess and the rear pin 42 will enter the adjacent recess 41 of the worm 39, whereupon rotation of the shaft will cause the worm to rotate and the segmental gear 33 will be swung in either a clock-wise or counter clock-wise direction, depending upon the direction in which the shaft is rotated. It will be understood that when the supporting section 17 is in its horizontal position the lugs 35 and 36 on the upper side of the rear bell crank 25 and segmental gear 33 will lie in substantial contact, so that when the worm 39 is engaged by the operating shaft and the latter turned in the proper direction, the lugs on the gear and bell crank will act to rotate the latter in a counter clockwise direction and lift the thigh section, and if the shaft is turned in the reverse direction the gear will be turned and said thigh section lowered. At any position of adjustment of either section the shaft may be disengaged from the worm employed to elevate such section and engaged with the other worm, the disengaged worm acting as an irreversible member of the connecting elements, or as a lock to maintain the section previously elevated in

its elevated position. By the arrangement just described the body and thigh supporting sections may be raised or lowered independently of each other, and either supported in any desired position while the position of the other is being adjusted, all of which may be accomplished by the operator from a single position.

As shown in Fig. 2, the link 30 is pivotally secured at its front end to one arm of the front bell-crank, as by bolt 30' threaded into the bell-crank with a lock-nut thereon; while the other end of link 30 extends through a connecting device 43 mounted on the rear arm of the rear bell-crank 25. As clearly shown in Fig. 4 the link 30 projects through an opening 44 in member 45, which is provided with a stud 46 pivotally secured to the arm of the bell-crank and may be held in such position by a collar 47 in the form of a nut as shown, or any other suitable means. The link 30 is provided at one side with a longitudinally extending notch 48. The member 45 is provided with a pocket 49, in which an adjustable member, which in the present case is shown in the form of a spring-pressed plunger 50 carried by a knob member 51 is disposed. A spring 52 is disposed between a cap member 53 carried by the member 45 and the plunger head to press the latter into operative position. The cap member 53 and knob member 51 have cooperating cam surfaces, as clearly shown in Fig. 4. When the parts are in the position shown in said figure the plunger head is disposed within the notch 48 thereby limiting longitudinal movement of the link 30 with respect to the member 45. Upon turning the knob member to bring one of the high points of its cam surface into the recess 54 of the other cam surface the plunger 50 is withdrawn from the notch 48 and locked in such withdrawn position thereby permitting free sliding movement of the link 30 in the member 45.

It will now be apparent that when the plunger 50 is withdrawn from the notch 48, the link 30 may move freely through opening 44, thus permitting the thigh section 17 to remain inoperative while the worm 38 is engaged with the operating shaft and the body section 16 is raised and lowered, and likewise permitting the body section 16 to remain inoperative while the worm 39 is engaged with the operating shaft and the thigh section 17 is raised or lowered. When the plunger extends into the notch 48 and the worm 38 engages with the operating shaft and the latter is turned in the proper direction to lift the body section, the thigh section will remain in normal position while the body section is being raised until the shoulder 55 contacts with the plunger 50, and thereafter both sections will be raised simultaneously; and when the body section is lowered contact of shoulder 56 with the

plunger 50 will rock the bell crank 25 and restore it to its normal initial position, very slightly to the left of the position shown in Fig. 2, and lower the thigh section to normal horizontal position. By proper manipulation of the single actuating member, therefore, the thigh supporting section and the body section may be independently adjusted, or the body supporting section may be partly elevated and the body and thigh supporting sections then raised together, and lowered in reverse order, as before explained.

The means for operating the drive shaft 40 comprise a crank 57 having a forked hub with elongated holes 58 therein. A pin 59 carried by shaft 40 near its rear end extends outwardly through the holes 58 thereby furnishing pivotal and slidable support for the hub of the crank. The shaft 40 is also provided with another pin 60 and the hub with a slot 60' adapted to slip over the pin 60 thereby holding the crank in operative position, and when desired to place the crank out of the way, longitudinal movement of the crank hub relative to the shaft will release it from restraint of the pin 60, and the crank may be swung around underneath the bed along-side the shaft 40, where it may rest upon bracket 61, which supports the rear end of the shaft and is provided with a raised portion 62 adapted to prevent the free end of the crank from slipping off the bracket and maintain it in its inoperative or out-of-the-way position.

It is desirable to provide means for maintaining the leg section 20 in the desired relationship with respect to the thigh section when the latter is elevated. For this purpose a brace bar 63 is provided at each side of the sections. In the construction shown the brace bars are carried by the thigh section 17 and are adapted to engage suitable notches provided on the leg section 20. This arrangement, however, might be reversed and the braces mounted on the leg section, as will be readily understood. The function of the braces is more fully explained in Patent No. 1,658,777, issued February 7, 1928, to M. C. Nixon. It is often desirable to remove the braces 63 or to place them in an out-of-the-way position. With this in mind studs 64 on the inner faces of the side members of the thigh section 17, on which the braces are adapted to pivot or swing, have been provided. Each brace 63 is releasably held in position on its stud by a spring member 65 (see Fig. 5) pivotally connected at one end to the side frame member, as by rivet 66, and is so formed and shaped at its other end that it is adapted to snap over the end of the stud 64 and hold the brace in position thereon. The arrangement is such that the braces 63 may be readily detached by removing the free end of the spring member 65. Upon releasing the free ends of the spring members from

engagement with the studs, they may be swung downward and in such position the braces 63 may be slipped from the studs 64 and into the pockets provided in the free ends of said spring members and thereafter the braces and the springs may be replaced on the studs and thus locked in an out-of-the-way position.

While the preferred embodiment of the invention has been shown and described it is not the intention to limit to the details shown as it is obvious that changes may readily be made without departing from the spirit of the invention.

What we claim is:

1. In a structure of the class described, the combination of a base frame, a pair of supporting sections each pivotally supported at one end by said base frame, operating members connected with said sections, mechanism to actuate said members independently, an element having a longitudinally extending notch at one end thereof and pivoted at its other end to one of said members, and a spring-pressed plunger carried by the other operating member projecting into said notch for providing a lost motion connection.

2. In a structure of the class described, the combination of a base frame, a pair of supporting sections each pivotally supported at one end by said base frame, operating members connected with said sections, means for actuating said members independently, means for connecting said members comprising an element having a longitudinally extending notch near one end thereof and pivotally secured at its other end to one of said members, a spring-pressed member carried by the other operating member and adapted to project into said notch, and means operable to hold said spring pressed member in retracted position.

3. In a structure of the class described, the combination of a base frame, a pair of supporting sections each pivotally supported at one end by and adapted to be swung upwardly from said base frame, operating members connected with said sections, means to operate said members independently, and means for connecting said operating members, comprising an element pivoted at one end to one of said members and having a limited longitudinal sliding lost motion connection with the other member, and a two-positioned member carried by said last mentioned operating member for operatively connecting the said element thereto whereby the free end of one or both of the supporting sections may be adjusted to different positions above the base frame by actuation of one of the operating members.

4. In a structure of the class described, the combination of a base frame, a pair of supporting sections each pivotally supported at one end by said base frame, operating mem-

bers connected with said sections, mechanism for operating said members independently, means for connecting said members comprising an element pivoted at one end to one of
 5 said members, and pivoted means including an adjustable member for operatively connecting said element with the other operating member permitting a limited sliding movement between said element and the other
 10 operating member, thereby providing a lost motion connection whereby the free end of one section may be raised a predetermined distance first and then both sections raised simultaneously.

15 5. In a structure of the class described, the combination of a base frame, a pair of supporting sections each pivotally supported at one end by said base frame, operating members connected with said sections, mechanisms for operating one of said members, and
 20 means operatively connected with one of the operating members and having a longitudinal sliding lost motion connection with the other operating member whereby the free end of one supporting section may be raised a pre-
 25 determined distance first and then both sections raised simultaneously.

30 6. In a structure of the class described, the combination of a base frame, a pair of supporting sections each pivotally supported at one end by said base frame, members operatively connected with said respective sections, means for operating one of said members,
 35 mechanism for connecting said members comprising an element pivoted at one end to one of said members and having a longitudinally sliding connection with the other member, means carried by said last mentioned member for operatively connecting said element
 40 thereto, and means including a two-positioned member whereby said last mentioned connection may be made inoperative.

45 7. In a structure of the class described, the combination of a base frame, a pair of supporting sections each pivotally supported at one end by and adapted to be swung upwardly from said base frame, members operatively connected with the respective sections, means to actuate said members independently and
 50 also conjointly, said means including a shaft shiftable horizontally and means for optionally interconnecting said operating members comprising a link pivoted at one end to one of said operating members, and slidably connectable to the other of said operating members whereby the free end of the supporting section connected with the last mentioned member may be raised or lowered by the action of the first mentioned member.

60 8. In a structure of the class described, the combination of a base frame, a pair of supporting sections each pivotally supported at one end by and adapted to be swung upwardly from said base frame, rock-shafts rotatably
 65 supported by said base frame and operatively

connected with the respective supporting sections, members carried by said rock-shafts, means for operating said members independently, and means for optionally interconnecting said members comprising an element pivotally secured at one end to one of said members and extending to and having a longitudinal lost motion connection with the other of said members, whereby the free end of one or both of these supporting sections may be adjusted to different positions above the base frame by actuation of one of the operating members.

70 9. In a structure of the class described, the combination of a base frame, a pair of supporting sections each pivotally supported at one end by and adapted to be swung upwardly from said base frame, members operatively connected with said respective supporting sections. means for operating one of said members independently, mechanism for connecting said members comprising a link pivoted at one end to one of said members and having a longitudinal sliding lost motion connection with the other of said members, said link being so arranged that it will upon greater movement than permitted by the lost motion connection restore said member having the lost motion connection with the link to its normal position, thereby returning the section connected therewith to its lowered position.

100 10. In a structure of the class described, the combination of a base frame, a pair of supporting sections each pivotally supported at one end by said base frame, members operatively connected with the respective supporting sections, means for operating one of said members independently, and mechanism for connecting said members comprising an element attached at one end to one of said members and having a lost motion connection with the other of said members, said lost motion connection serving upon lowering the section connected with the independently operated member to force the other member in a direction to cause the supporting section connected therewith to its lowered position.

115 11. In a structure of the class described, the combination of a base frame, a pair of supporting sections each pivotally supported by said base frame, mechanism for adjusting the positions of the supporting sections comprising a pair of rock shafts rotatably supported by the base frame, an operating means secured to one of said rock shafts, an operating member loosely carried by the other rock shaft and a lever secured on said shaft, co-operating contact members between said lever and said operating member providing a lost motion connection therebetween, an element pivotally connected with the said operating means and having a lost motion connection with said lever, and means for actuating the said operating means, whereby
 120
 125
 130

said lever may be moved independently of said operating member to lift its associated supporting section.

12. In a structure of the class described, the combination of a base frame, a pair of supporting sections each pivotally supported at one end by said base frame and arranged to permit elevation of the free end of each section above said base frame, operating means for raising each of said sections about its pivotal support, a single means for selectively actuating said operating means, and means for optionally interconnecting said operating means to effect simultaneous actuation thereof through said single actuating means.

13. In a structure of the class described, the combination of a base frame, a central section secured to the base frame, a pair of supporting sections each pivotally secured at one end to the respective ends of the central section, levers pivotally supported by the base frame, means operable by said levers and pivotally attached to the respective supporting sections, the levers connected with one of said sections being reversely positioned with respect to said section and adapted to swing toward the pivots thereof when raising the free end of said section, a rotatable actuating member disposed longitudinally with respect to the structure, and a pair of operating means operatively associated with said actuating member and adapted for selective engagement therewith and operatively connected with said levers whereby the free end of either supporting section may be raised upon rotating said actuating member and associated operating means in one direction and either may be lowered upon rotating same in the opposite direction.

14. In a structure of the class described, the combination of a base frame, a pair of supporting sections each pivotally supported at one end by said base frame, levers pivotally supported by the base frame and operatively connected with the respective supporting sections, the levers connected with one of said sections being reversely positioned with respect to said section and adapted to swing toward the pivots thereof when raising the free end of said section, a rotatable actuating member disposed longitudinally with respect to the structure, and a pair of similarly constructed operating means operatively associated with said actuating member and adapted for selective engagement therewith and operatively connected with said levers whereby the free end of either supporting section may be raised upon rotating said actuating member and associated means in one direction and either may be lowered upon rotating same in the opposite direction.

15. In a structure of the class described, the combination of a base frame, a pair of supporting sections each pivotally supported

at one end by said base frame, levers pivotally supported by said base frame and operatively connected with the respective supporting sections, the levers connected with one of said sections being reversely positioned with respect to said section, a rotatable and slidable actuating member disposed longitudinally with respect to the structure, and a pair of similarly constructed operating means adapted for selective engagement with said actuating member and operatively connected with said levers whereby the free end of either supporting section may be raised upon rotating said actuating member in one direction and either may be lowered upon rotating same in the opposite direction.

16. In a structure of the class described, the combination of a base frame, a pair of supporting sections each pivotally supported at one end by said base frame, and means for raising and lowering said sections relative to said base frame comprising gear elements, levers operatively connected with said respective gear elements, links pivotally connecting said levers with the respective supporting sections, worms meshing with said respective gear elements, an actuating member rotatably and slidably mounted in said worms, and means carried by said worms and by said actuating member and cooperatively related for selectively operatively connecting the actuating member with the respective worms.

17. In a structure of the class described, the combination of a base frame, a pair of supporting sections each pivotally supported at one end by said base frame, operating means including links pivotally connected with the respective sections, an actuating shaft rotatably and slidably supported by said means, and sets of cooperating elements carried by the shaft and said operating means whereby a longitudinal movement of the shaft releases one set of said elements and operatively connects the other set.

18. In a structure of the class described, the combination of a base frame, a pair of supporting sections each pivotally supported at one end by said base frame, gears operatively connected with said sections, worms operatively connected with said gears, an actuating member rotatably mounted loosely in said worms, and co-operating means carried by said member and worms adapted to connect said member to either one or the other of said worms.

19. In a structure of the class described, the combination of a base frame, a pair of supporting sections each pivotally supported at one end by said base frame, gear elements operatively connected with the respective supporting sections, worms meshing with the respective gear elements, a rotatable actuating member loosely supported in said worms, and co-operating elements carried by the ac-

70

75

80

85

90

95

100

105

110

115

120

125

130

tuating member and the respective worms adapted to operatively connect said member with either one or the other of said worms whereby the free end of the supporting sections may be raised or lowered relative to the base frame.

20. In a structure of the class described, the combination of a base frame, a pair of supporting sections each pivotally supported at one end by said base frame, means operatively connected with the respective supporting sections, a rotatable actuating member loosely supported by said operative means, and co-operative elements carried by the actuating member and respective operative means for selectively operatively connecting said member with either one or the other of said operative means whereby the free end of the supporting sections may be raised or lowered relative to the base frame.

21. In a structure of the class described, the combination of a base frame, a pair of supporting sections each pivotally supported at one end by said base frame, gear elements operatively connected with the respective supporting sections, worms meshing with the respective gear elements and held against longitudinal movement, a rotatable actuating member loosely mounted in said worms, and co-operative elements carried by the actuating member and the respective worms for selectively connecting the actuating member with the respective worms whereby the free end of either supporting section may be raised or lowered relative to the base frame.

22. In a structure of the class described, the combination of a base frame, a pair of supporting sections each pivotally supported at one end by said base frame, rock-shafts pivotally supported by said base frame, operating means severally including said rock-shafts and operatively connected with the respective supporting sections, a single rotatable actuating member, and co-operating elements carried by said actuating member and an element of the respective operative means whereby the former may be operatively connected with or disconnected from the latter for raising or lowering the free end of either supporting section.

23. In a structure of the class described, the combination of a base frame, a pair of supporting sections each pivotally supported at one end by said base frame, rock-shafts pivotally supported by said base frame, members carried by the rock-shafts and operatively connected with the respective supporting sections, mechanism comprising a single rotatable actuating member, and devices for selectively connecting the actuating member with or disconnecting it from the respective rock-shafts whereby the free end of either supporting section may be raised or lowered relative to the base frame.

24. In a structure of the class described,

the combination of a base frame, a pair of supporting sections each pivotally supported at one end by said base frame, gear elements operatively connected with the respective supporting sections, worms meshing with the respective gear elements and held against longitudinal movement, a rotatable actuating member loosely mounted in and supported by said worms, and co-operative elements carried by the actuating member and said worms for selectively operatively connecting the actuating member with the respective worms whereby the free end of either supporting section may be raised or lowered relative to the base frame.

25. In a structure of the class described, the combination of a base frame, a pair of supporting sections each pivotally supported at one end by said base frame, gear elements operatively connected with the respective supporting sections, worms meshing with the respective gear elements, means for rotatably supporting said worms adapted to hold the latter against longitudinal movement, an actuating member rotatably mounted in said worms, and co-operative means carried by the actuating member and the respective worms adapted by a longitudinal movement of the actuating member to selectively form an operative connection with one or the other of said worms whereby the free end of either supporting section may be raised or lowered relative to the base frame.

26. In a structure of the class described, the combination of a base frame, a pair of supporting sections each pivotally supported at one end by said base frame, and mechanism for selectively adjusting the position of the respective supporting sections comprising rock-shafts pivotally supported by said base frame, means operatively connecting the rock-shafts with the respective supporting sections, a single rotatable actuating member, co-operative elements for selectively connecting the actuating member with or disconnecting it from the respective rock-shafts for independently raising or lowering the free ends of said sections, and irreversible means included in said mechanism whereby the free end of either supporting section may be supported in a raised position while the free end of the other supporting section may be raised or lowered relative to the base frame.

MOSES C. NIXON.
ALEXANDER F. KAPTULLER.