

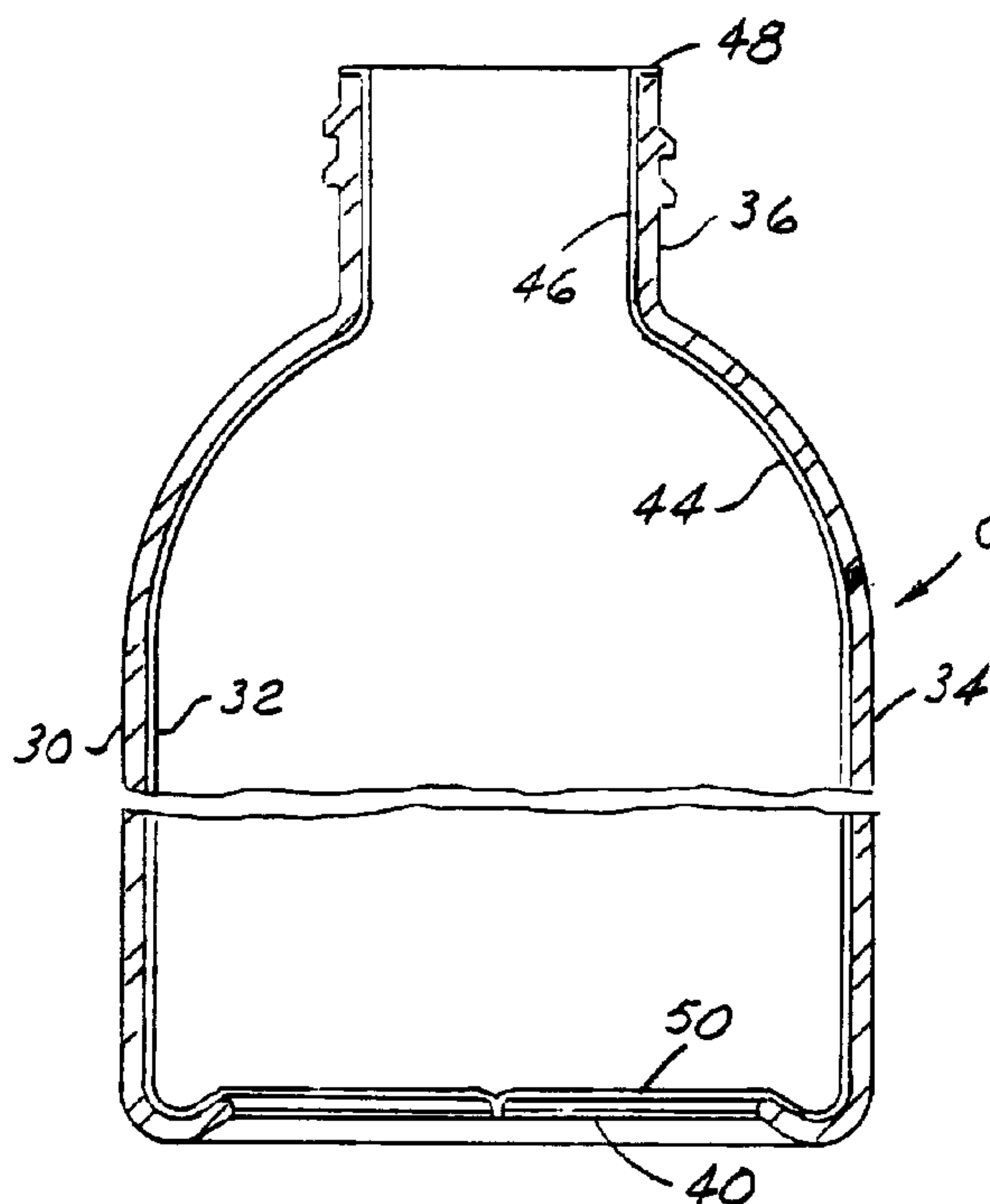

(22) Date de dépôt/Filing Date: 1998/02/27  
 (41) Mise à la disp. pub./Open to Public Insp.: 1998/08/28  
 (45) Date de délivrance/Issue Date: 2007/02/13  
 (30) Priorité/Priority: 1997/02/28 (US08/807,944)

(51) Cl.Int./Int.Cl. *B65D 23/02* (2006.01),  
*B05B 11/00* (2006.01), *B29C 49/22* (2006.01),  
*B29C 49/50* (2006.01), *B65D 1/40* (2006.01),  
*B29C 49/04* (2006.01)  
 (72) Inventeur/Inventor:  
 SAFIAN, JOHN W., US  
 (73) Propriétaire/Owner:  
 GRAHAM PACKAGING PLASTIC PRODUCTS INC., US  
 (74) Agent: GOWLING LAFLEUR HENDERSON LLP

(54) Titre : CONTENANT MULTICOUCHE  
 (54) Title: MULTILAYER CONTAINER PACKAGE



(57) **Abrégé/Abstract:**

A multilayer container including an outer relatively rigid plastic layer having a body portion, a finish defining an opening and a base having an atmospheric vent opening therethrough. The container includes an inner flexible plastic layer of relative thin flexible material throughout which does not adhere to the outer plastic layer. The inner flexible layer has a closed bottom portion engaging the inner surface of the finish of the outer plastic layer and a radially extending flange portion of the inner layer overlying the finish of the outer layer. The outer layer preferably comprises an olefin and the inner layer preferably comprises amorphous nylon. The method of making the multilayer container includes coextruding a parison comprising the relatively thick outer layer of plastic material and the relatively thin inner layer of plastic material, closing molds about the parison, blow molding the parison to form the outer rigid plastic layer having a body portion, the finish defining an opening, and the base and the inner flexible layer of relatively thin flexible material.

**Abstract of the Disclosure**

5 A multilayer container including an outer relatively rigid plastic layer having a body portion, a finish defining an opening and a base having an atmospheric vent opening therethrough. The container includes an inner flexible plastic layer of relative thin flexible material throughout which does not adhere to the outer plastic layer. The inner flexible layer has a closed bottom portion engaging the inner surface of the finish of the outer plastic layer and a radially extending flange portion of the inner layer overlying the finish of the outer layer. The outer layer preferably comprises an olefin and the inner layer preferably comprises amorphous nylon. The method of making the multilayer container includes coextruding a parison comprising the relatively thick outer layer of plastic material and the relatively thin inner layer of plastic material, closing molds about the parison, blow molding the parison to form the outer rigid plastic layer having a body portion, the finish defining an opening, and the base and the inner flexible layer of relatively thin flexible material.

10

15

## MULTILAYER CONTAINER PACKAGE

This invention relates to multilayer containers and particularly to multilayer container packages that comprise an outer relatively rigid plastic container and an inner relatively thin plastic container.

### Background and Summary of the Invention

One type of container which is well known comprises an outer relatively rigid plastic layer and an inner relatively flexible inner layer. The outer layer is provided with an atmospheric vent opening such that the inner flexible layer collapses and delaminates from the outer layer when the liquid contents are dispensed. In the manufacture of such containers, it is common to apply a differential pressure to insure that the delamination will occur. In addition, it is usually necessary to trim the containers. Typical containers are shown, for example, in United States patents 5,435,452 and 5,513,761. Such containers are used with dispensers such as pump dispensers or spray dispensers and the inner layer, sometimes called a bag, is made of a resin which is compatible with the liquid contents.

Among the objectives of the invention are to provide a multilayer container wherein the container does not require trimming and the like; wherein the atmospheric vent opening is obtained during the blow molding of the package; wherein any tendency of the inner layer to adhere to the outer layer is eliminated; and wherein no delamination step is required in the manufacture.

In accordance with the invention, the multilayer container comprises an outer relatively rigid plastic layer having a body portion, a finish defining an

opening and a base. The outer rigid layer has an atmospheric vent opening  
therethrough. The container includes an inner flexible plastic layer of relative  
thin flexible material throughout which does not adhere to the outer plastic layer.  
The inner flexible layer has a closed bottom portion engaging the inner surface of  
5 the finish of the outer plastic layer and a radially extending flange portion of the  
inner layer overlying the finish of the outer layer. The outer layer preferably  
comprises an olefin and the inner layer preferably comprises amorphous nylon.  
The method of making the multilayer container includes coextruding a parison  
comprising a relatively thick outer layer of plastic material and a relatively thin  
10 inner layer of plastic material, the outer plastic material and inner plastic material  
being such that the layers will not adhere to one another, closing molds about the  
parison, blow molding the parison to form an outer rigid plastic layer having a  
body portion, a finish defining an opening, and a base and an inner flexible layer  
of relatively thin flexible material throughout which does not adhere to the outer  
15 plastic layer and the inner flexible layer having a portion engaging the inner  
surface of the finish of the outer plastic layer and a radially extending flange  
portion of the inner layer overlying the finish, and simultaneously forming an  
atmospheric vent opening to the outer layer. During the blow molding, the base  
of the outer layer is formed with an outer generally planar surface and a  
20 diametral slit. A portion of the inner layer extends along the inner surface of the  
base of the outer layer and a portion of the inner layer extends into the opening  
but not beyond the outer surface of the base. When the contents are dispensed  
by a differential pressure, air enters through the vent opening and the inner layer  
readily delaminates from the outer layer without the need of any prelamination  
25 step in the making of the container.

#### **Description of the Drawings**

Fig. 1 is an elevational view of the multilayer container embodying the invention.

Fig. 2 is a top plan view.

Fig. 3 is a bottom plan view.

Fig. 4 is a sectional view taken along the line 4-4 in Fig. 2.

Fig. 5 is a sectional view on an enlarged scale taken along the line 5-5 in Fig. 2.

5 Fig. 5A is a sectional view on a greatly enlarged scale taken at the circle 5A in Fig. 5.

Fig. 6 is a partly diagrammatic vertical sectional view of the apparatus for forming the finish of the container.

10 Fig. 7 is a sectional view showing the apparatus of Fig. 6 in a different operative position.

Fig. 8 is a sectional view showing the apparatus of Fig. 7 in a further operative position.

Fig. 9 is an enlarged view taken at the circle 9 in Fig. 8.

15 Fig. 10 is a sectional view showing the apparatus of Fig. 8 in a further operative position.

Fig. 11 is an enlarged view taken at the circle 11 in Fig. 10.

Fig. 12 is a partly diagrammatic view showing the movement of the inner layer relative to the outer layer during dispensing of the contents.

Fig. 13 is a similar view of a prior art container.

20 Fig. 14 is a fragmentary sectional view on an enlarged scale of the container embodying the invention with a closure and pump in position.

Fig. 15 is a fragmentary sectional view on a greatly enlarged scale of a portion of the assembly shown in Fig. 14.

25 Fig. 16 is an elevational view of a tail puller associated with the blow mold.

Fig. 17 is an end view taken from the right in Fig. 16.

Fig. 18 is a perspective view of one of the molds showing the tail removed from the container.

Fig. 19 is a fragmentary perspective view of a portion of Fig. 18.

Fig. 20 is a fragmentary perspective view on an enlarged scale of a portion of Fig. 19.

### Detailed Description of the Preferred Embodiments

Referring to Figs. 1-5A, the container C embodying the invention  
 5 comprises an outer relatively rigid plastic layer 30 and an inner relatively thin  
 inner layer 32. The outer layer 30 includes a body portion 34, a finish 36 and a  
 base 38 having a diametral slit 40 defining an atmospheric vent opening 42. The  
 inner layer 32 comprises a body portion 44, a finish portion 46 extending along  
 the inside surface of the finish 36 of the outer layer and having a radial flange 48  
 10 overlying the radial surface of the finish 36. The bottom 50 of the inner layer is  
 closed.

The container is made by coextruding a parison, closing molds about the  
 parison and blow molding the parison. A preferred apparatus is shown in United  
 States Patent Nos. 3,781,395, 3,767,747 and 3,978,184.

15 In accordance with the invention, a blowpin assembly 52 is provided  
 which applies air to blow the layers and shape the flange 48 and sever the moil.  
 The blowpin assembly is composed of a blowpin tip 54, a cutter 56, a spacer 58  
 and a sleeve 60. These components are assembled together and attached onto a  
 20 blowpin station stem. Expansion air is blown through the assembly to blow the  
 container. The blowpin tip 54 is sized so that specific container finish and neck  
 dimensions are achieved. The cutter 56 is sized to be about .010 inches larger in  
 diameter than the diameter of anvil 62 so that it can fold and flatten the inner  
 layer over the outer layer. In addition, it pinches the extra parison portion or  
 25 moil between the anvil and the cutter 56. This cutting is the result of the  
 downward motion of the blowpin assembly cutter 56 against the anvil. The  
 sleeve 60 is larger in diameter than the bottom of the opening in the anvil 62, for  
 example approximately .030 inch, and is used as an air deflector which both  
 cools the severed moil and acts as a carrier which removes the moil as the

blowpin assembly 52 moves upward and away from the finished container. The spacer 58 establishes the position of the blowpin tip 54 and cutter 56 at the proper depth in relation to the mold and sleeve away from the anvil surface. It also has through-holes drilled therein such that air can be channeled to the sleeve.

5           In the blow molding cycle, the open molds are transferred from a resting position to an up and under position relative to the free-flowing parison. At the correct time, the molds are closed and the parison is cut. The closed mold is transferred to a down and resting position where the blowpin station is positioned over the mold. The machine control then moves the blowpin assembly 52  
10 downward towards the mold and enters the mold through the anvil 62. Fig. 6 shows this entry point of the blowpin assembly, position and shape of the top portion of the hot parison. The top portion of the cut parison and above the bottom of the anvil is called the moil. It is cone-like in shape and lays around the upper portion of the anvil 62.

15           Referring to Figs. 7 and 8, the blowpin assembly 52 is shown down and bottomed against the anvil 62 and mold. Since the blowpin 54 entered the inner layer of the multilayer container, the cutter 56 first comes in contact with the parison. It will tend to push outward, flatten and then compress the inner layer against the outer layer as in Fig. 9. When the blowpin assembly 52 reaches its  
20 final downward travel, the sharp cutter edge 56 will pinch and cut both layers against the sidewall of the anvil 62. During this time, expansion air is flowing thru the spacer 58, sleeve 60 and the severed parison so that the moil M will form around the sleeve 60. As the blow cycle is complete and the blowpin assembly is moved upward, the moil M stays on the assembly to be stripped  
25 away, as shown in Fig.10. Fig. 9 shows flange 48 created during molding. The moil M is removed as the blowpin assembly 52 is removed from the container. With a finished flange 48, a finger pump or trigger sprayer with a closure can be secured to the container. The compression of closure against the flange will create an hermetic seal between these layers at the mouth of the container. As a  
30 result, a gasket is not required between the closure and flange.

Referring to Fig. 12, this figure shows the difference between a collapsible inner layer or bag or multilayer container with a flange and no adhesive used. In Fig. 11, the flange 48 which was molded over the finish will prevent the air from flowing into the bag from the atmospheric vent. The compression of the closure without a gasket compresses together both the inner layer flange 48 and radial surface of the finish 36 on the outer layer 30. This prevents the vacuum from escaping. The prior art container shown in Fig. 13 will not retain vacuum because the outside air will flow up through the vent, between layers across the closure and through the pumping device.

In accordance with another aspect of the invention, the outer container is made of olefin plastic, preferably high density polyethylene (HDPE) and the inner container is made of amorphous nylon. Amorphous nylon as used herein means a polyamide that is not crystalline in the sense that it does not display any crystalline melting point as measured by differential scanning calorimetry. In the preferred embodiment, the amorphous nylon is made by condensation of hexamethylene diamine, isophthalic acid and terephthalic acid.

Thus, the inner layer of a multilayer container delaminates or separates from the outer layer easily without additional handling or using a secondary machine operation. The layer separation is accomplished by choosing resins which do not adhere to each other and satisfy customer criteria. In a functional multilayer container package, the neck is sealed with a finger pump or similar device which is used to create a vacuum that will draw the contents out while collapsing the inner layer. Outer layer deformation is not an acceptable effect. No adhesives are used between the different thermoplastic layers. Using an outer layer of high density polyethylene together with amorphous nylon will function correctly and meet the above criteria.

Processing with differently structured nylons such as an amorphous nylon results in the inner layer significantly separating with less force than is required with other resins such as a crystalline structured nylon.

In addition to the aforementioned advantages of utilizing amorphous nylon, the following advantages are achieved in the container made utilizing amorphous nylon:

1. Eliminate predelamination of the inner layer relative to outer layer of a bag in a bottle type multilayer container. The predelamination is defined as any method of pre-separating the inner from the outer layer prior to filling the container with a product.

2. Less force or vacuum is required to separate the inner layer from the outer layer. Typically, the container is filled with a product and evacuated without extra handling or predelaminating the inner layer so to help it function. A finger pump or trigger sprayer device is used to evacuate product and collapse the inner bag together.

3. Does not require special equipment or extra secondary processing which injects or traps air between layers.

4. Eliminates container outer wall deformation.

5. Eliminates using multiple atmospheric vent holes in the container outer layer.

Previous designs need to inject air or gas through holes made in the base and/or sidewalls of the outer layer of a multilayer container to help separate layers. Other designs have extensive processing steps or expensive equipment to separate the inner from the outer layer before it is filled with a product. The amorphous nylon does not require any predelamination to separate the nylon from a HDPE layer when the container is evacuated with product. Using a thin layer of amorphous nylon of approximately .002 to .006 in. thick as an inner layer and a outer layer of HDPE of .020 in. or greater thickness will separate as previously mentioned without extra handling. The thickness of the inner amorphous nylon layer is uniform throughout but can vary depending on the oxygen barrier requirements and package functional requirements. Using a crystalline structured nylon requires a force or vacuum two times or greater to separate the inner layer from the outer layer. This causes container outer wall

deformation and is very undesirable. When processing, a co-crystalline barrier may be developed between the HDPE and the crystalline nylon. Crystalline nylon which shows these characteristics are Allied-Signal's Capron Xtraform XPN1539F and also CA73YP. A satisfactory amorphous nylon, Sclar PA 3426, made by DuPont results in good separation from the HDPE.

Amorphous nylon does not have a defined crystalline melting point, as contrasted with crystalline, and therefore softens as the melt temperature increases over a large range. Amorphous nylon is a polyamide made by condensation of hexamethylene diamine, isophthalic acid and terephthalic acid. Amorphous nylon has better oxygen, moisture and carbon dioxide barrier properties especially at high humidities when compared to crystalline nylon. Amorphous nylon has better transparency, higher gloss and lower haze than crystalline nylon. It has been found that an amorphous nylon inner layer tends to shrink away from the outer layer and eliminates any tendency for adhering to the outer layer, as contrasted to crystalline nylon. The properties of amorphous nylon and crystalline nylon can be compared by reference to the following:

Melting Point Differential Scanning Calorimeter (DSC)

Amorphous Nylon (Sclar Pa 3426): No melting point

Crystalline Nylon (Capron): 201.94°C

High Density Polyethylene (Paxon): 132.03°C

Oxygen Permeation

Amorphous Nylon: 1.3 cc/mil/100 in.sq./24 hr/atm (95% RH) @ 77°F

Crystalline Nylon: 12 cc/mil/100 in.sq./24 hr./atm (95%RH) @ 77°F

Carbon Dioxide Permeation

Amorphous Nylon: 6 cc/mil./100 in.sq./24 hr/atm (95% RH) @ 77°F

Crystalline Nylon: 120 cc/mil/100 in.sq./24 hr./atm (95% RH) @ 77°F

Moisture Vapor Transmission Rate

Amorphous Nylon: 1.85 gm/100 in.sq./24 hr. @ 95% RH @ 73°F

Crystalline Nylon: 12.44 gm/100 in.sq./24 hr. @ 95% RH @ 73°F

Optical Properties Transparency (1 mil blown film)

Amorphous Nylon: 70% Total

Crystalline Nylon: 10 % Total

Although the multilayer container has been described as comprising two layers, the container may have more layers as shown in the following examples:

Example I

|   |             |                           |
|---|-------------|---------------------------|
| 5 | outer layer | high density polyethylene |
|   | inner layer | amorphous nylon           |

Example II

|                    |  |
|--------------------|--|
| outer layer        | high density polyethylene                  |
| inner layer        | amorphous nylon                            |
| intermediate layer | composite of outer and inner layer regrind |

10

TESTING

Test I

A layer breakaway comparative test was made between containers having an outer layer of high density polyethylene and an inner layer of the crystalline or amorphous nylon. A vacuum gage was attached to each test sample. Vacuum was generated until a peak reading was achieved on the gage. After the peak reading was reached, a dropoff of vacuum was expected. The peak reading is the force it takes to separate the inner layer from the outer layer. The vacuum dropoff reading occurs when the layers separate. All test containers had atmospheric vents created in their bases. The test was aborted if the sidewall panels collapsed before the inner layer separated or vacuum dropoff was not achieved.

Table I

| Sample | Capron<br>XPN1539F | Capron<br>CA73YP | Sclar<br>PA 3426 |
|--------|--------------------|------------------|------------------|
| 1      | 200 - SWD          | 200 - SWD        | 100-60-NSWD      |
| 2      | 200 - SWD          | 200 - SWD        | 90-60-NSWD       |
| 3      | 200 - SWD          | 200 - SWD        | 100-80-NSWD      |
| 4      | 200 - SWD          | 200 - SWD        | 100-70-NSWD      |
| 5      | 180 - SWD          | 210 - SWD        | 50-50-NSWD       |
| 6      | 160 - SWD          | 200 - SWD        | 90-50-NSWD       |
| 7      | 160 - SWD          | 210 - SWD        | 120-50-NSWD      |
| 8      | 180 - SWD          | 220 - SWD        | 120-70-NSWD      |
| 9      | 190 - SWD          | 210 - SWD        | 110-70-NSWD      |
| 10     | 150 - SWD          | 200 - SWD        | 110-70-NSWD      |

All measurements are MM-HG

S.W.D. indicates sidewall deformation. Vacuum dropoff was not achieved.

N.S.W.D. indicates no sidewall deformation. Vacuum dropoff was achieved.

The third column indicates two numbers. The left number is the peak vacuum and the right number is when the collapsed inner layer lifts from the base of the container.

Test II

A visual observation test was performed. Two groups of test samples were collected. Test group one consisted of containers which have an amorphous nylon inner layer and high density polyethylene as the outer layer. Test group two was composed of crystalline nylon as the inner layer and the same high density polyethylene as the outer layer. No adhesives were used between layers. The container panels were removed from both groups of containers. The test consisted of separating the layers by hand to observe the ease of separation and to view any material which would adhere to one of the layers. Group one was found to have no peeling, material threading or adhering between layers. Actually, they slipped apart from each other very easily. Test group two was

found to have fine material strands between the layers or layers which stick together, i.e., like glue.

In accordance with another aspect of the invention, the atmospheric vent is made during the blow molding of the parison without the need for further  
5 trimming.

In the present invention, the inner bag layer is not secured to the outer layer by adhesives, bonding, pinching or gathering at the base of the bottle, sidewalls or panels or at the neck of the container.

Current base tooling is modified to help start the creation of the  
10 atmospheric vent opening 42. The vent opening 42 is created across the central portion of the parting line at the base of the container. The tooling is designed so that the central portion of the parting line does not pinch the central portion of the tail as much as the remaining portions of the tail. The slot in the tooling for forming the vent opening is wider than the rest of the pinch line, for example, an  
15 additional .004 inch width (.002 in. per side) is provided for approximately 70% of the parting line width. The wider gap on the tooling creates additional clearance so that material is thicker at that point. The remaining parting line pinches the parison tail to less than .005 in. A tail removing device is attached to the mold so that when the tails are removed at the end of the machine cycle,  
20 more material is removed at the slit. This forms a wider gap than the remaining parting line. None of the material from the inner layer 32 extends entirely through the vent opening 42 to the generally planar outer surface of the base 38. As the container cools, the gap will widen slightly due to thermal shrinkage of the resins and the difference of thickness of the HDPE and amorphous nylon.

25 It can be seen that the finished vent opening 42 does not have a molded rib projecting downward. In a wet area, i.e., bathroom, the problem with a rib projecting downward is that it could come in contact with water and draw the water up between the layers.

If one or more decorating lugs L are provided on the outer surface of the  
30 base of the outer container for rotating the container during handling and

decorating, they are located in circumferentially spaced relation to the parting line and radially outwardly with respect to the vent opening 42 (Fig. 3).

Figs. 14 and 15 show the container embodying the invention with a closure and a ventless pump in the shipping position. The pump includes a  
5 ventless tank 70 having an integral flange 72; a threaded cap 74 having a radial flange 76; and integral axial locating elements 78 extending through an opening in the flange 76 to retain a closure 80 in position. An actuator 82 is snapped into a piston 84 after threaded cap 74 is snapped into the tank 70 and a closure is snapped over the axial locating elements 76. This assembly actuates piston 84  
10 and associated spring loaded ball 86 in accordance with conventional pump design after the actuator 82 is unthreaded out of shipping position. The flanges 72 and 76 are interposed between the base wall 88 of the closure and the flange on the inner layer overlaying the finish of the outer layer thereby providing a construction that does not require any other gasket or sealing. It can be seen that  
15 a flange is interposed between the base of the closure and the flange on the inner layer. Upon actuation of the pump, the product is dispensed and the differential pressure causes the bottom of the inner layer to lift off the base of the outer layer.

Partly diagrammatic Figs. 16-20 show the apparatus for forming the  
20 atmospheric vent opening in the outer layer of the container. Each mold half 90 wherein the container is blow molded has a bottom forming insert 92 with a radial recess 94 such that when the molds are brought together a slot is formed which pinches the central portion of a parison a lesser amount than the outer portions of the parison. A pair of tail puller assemblies 96 is provided to clamp  
25 the tail T defined by pinching the parison. Each tail assembly 96 includes serrated jaws 100 actuated by an air cylinder 98 when the molds close to grasp the tail. Toward the end of the molding cycle, while the molds are closed, cylinders 98 are actuated and serrated jaws 100 are pivoted and pulled  
30 downwardly to remove the tail T leaving a vent opening 42 in the outer layer of the container which has been blow molded.

It can thus be seen that there has been provided a multilayer container wherein any tendency of the inner layer to adhere to the outer layer is assured, wherein no delamination step is required in the manufacture; wherein the container does not require trimming and the like; and wherein the atmospheric vent opening is obtained during the blow molding of the package.

5

**Claims:**

1.

A multilayer container that comprises:

inner and outer layers that are coextruded and blow molded simultaneously with each other,

said outer layer being a relatively rigid plastic layer having a body portion, a finish having an axial end surrounding a dispensing opening, and a base having an atmospheric vent opening formed by removal of material from said base after blow molding,

said inner layer being a relatively thin flexible plastic layer that extends around an inner surface of said outer layer and is unadhered to said outer layer,

said inner flexible layer being of uniform thickness throughout, having a portion that overlies said vent opening, and having a portion engaging the inner surface of said finish and a radially extending flange portion overlying said axial end of said finish.

2.

The multilayer container set forth in claim 1 wherein said flange portion of said inner layer entirely overlies the end of said finish of said outer layer and terminates at an outer edge of said finish.

3.

The multilayer container set forth in claim 2 wherein said portion of said inner layer engaging said finish and overlying said finish is unadhered to said finish.

4.

The multilayer container set forth in claim 3 wherein said outer plastic layer comprises olefinic plastic and said inner flexible layer comprises amorphous nylon.

5.

The multilayer container set forth in claim 4 wherein said olefinic plastic comprises high density polyethylene.

6.

The multilayer container set forth in claim 2 including a product in said container, and a closure, and a dispenser on said finish of said outer layer such that the flange portion of the inner flexible container forms a seal with the closure.

7.

A multilayer container that comprises:

an inner liner and an outer shell that are coextruded and blow molded simultaneously with each other,

said outer shell being of relatively rigid plastic construction and having a body portion, a base with an atmospheric vent formed by removal of material from said base after blow molding, and a finish having an axial end surrounding a dispensing opening,

said inner liner being of relatively flexible plastic construction, extending around an inner surface of said outer shell, and being unadhered to said outer shell,

said inner liner being of uniform thickness throughout, having a portion that overlies said vent opening, and having a portion engaging the inner surface of said finish and a radially extending flange portion overlying said axially facing end of said finish.

8.

A multilayer container that is made by:

(a) providing a pair of mold halves that, when closed, define a blow mold cavity, with each of said mold halves including a bottom portion, for forming the container bottom, with an edge that abuts the opposing mold half, and a recess that

extends radially outwardly into the edge of the bottom portion of each mold half and axially entirely through said mold bottom portion,

(b) coextruding a parison comprising a relatively thick outer layer of plastic material, and a relatively thin inner layer of plastic material and uniform thickness throughout, said outer plastic material and inner plastic material being such that the layers will not adhere to one another,

(c) closing the mold halves around the hollow plastic parison such that said recesses in said edges of said bottom portions of the mold halves are brought together to form a diametric slot that extends axially through the abutting mold bottom portions, said bottom portions pinching the parison to form a tail that extends axially continuously through said slot from the mold cavity while remaining connected to the outer layer of the parison,

(d) blow molding said parison to form an outer rigid plastic layer having a base, a body portion and a finish defining an opening, and an inner flexible layer of relatively thin flexible material of uniform thickness throughout that does not adhere to said outer plastic layer, said inner flexible layer having a portion engaging the inner surface of the finish of the outer plastic layer and a radially extending flange portion of said inner layer overlying said finish, said base being integrally connected to said tail that extends through said slot formed by said mold halves,

(e) with the mold halves closed, clamping between a pair of tail pullers the tail that extends through said slot,

(f) pulling the tail away from the mold through said slot to sever the tail from the outer plastic layer within the mold cavity and leave an atmospheric vent opening in the outer plastic layer at the bottom of the container where the material of said outer plastic layer was pulled through said slot formed by said recesses in said mold halves, and then

(g) opening the mold halves to remove the container.

9.

The container set forth in claim 8 wherein the portion of said inner layer extending through said finish of said outer layer is unadhered to said finish.

10.

The container set forth in claim 9 wherein said outer plastic layer comprises olefinic plastic and said inner flexible layer comprises amorphous nylon.

11.

The method of making a multi-layer container including the steps of:

(a) providing a pair of mold halves that, when closed, define a blow mold cavity, with each of said mold halves including a bottom portion, for forming the container bottom, with an edge that abuts the opposing mold half, and a recess that extends radially outwardly into the edge of the bottom portion of each mold half and axially entirely through said mold bottom portion,

(b) coextruding a parison comprising a relatively thick outer layer of plastic material, and a relatively thin inner layer of plastic material and uniform thickness throughout, said outer plastic material and inner plastic material being such that the layers will not adhere to one another,

(c) closing the mold halves around the hollow plastic parison such that said recesses in said edges of said bottom portions of the mold halves are brought together to form a diametric slot that extends axially through the abutting mold bottom portions, said bottom portions pinching the parison to form a tail that extends axially continuously through said slot from the mold cavity while remaining connected to the outer layer of the parison,

(d) blow molding said parison to form an outer rigid plastic layer having a base, a body portion and a finish defining an opening, and an inner flexible layer of relatively thin flexible material of uniform thickness throughout that does not adhere to said outer plastic layer, said inner flexible layer having a portion engaging the inner

surface of the finish of the outer plastic layer and a radially extending flange portion of said inner layer overlying said finish, said base being integrally connected to said tail that extends through said slot formed by said mold halves,

(e) with the mold halves closed, clamping between a pair of tail pullers the tail that extends through said slot,

(f) pulling the tail away from the mold through said slot to sever the tail from the outer plastic layer within the mold cavity and leave an atmospheric vent opening in the outer plastic layer at the bottom of the container where the material of said outer plastic layer was pulled through said slot formed by said recesses in said mold halves, and then

(g) opening the mold halves to remove the container.

12.

The method set forth in claim 11 wherein said method is such that the portion of said inner layer extending through said finish of said outer layer is unadhered to said finish.

13.

The method set forth in claim 12 wherein said outer plastic layer comprises olefinic plastic and said inner flexible layer comprises nylon.

14.

The method set forth in any one of claims 11 to 13 wherein said blow molding comprises providing a combined blow pin and cutter which has a configuration for blowing, shaping the flange and cutting the parison to provide a finished container.

15.

Apparatus for blow-molding a hollow plastic container having an atmospheric vent in the bottom of the container, said apparatus comprising:  
a pair of mold halves that are closable to form a blow mold cavity,

each of said mold halves including a bottom portion with a radial recess that cooperates with the recess of the bottom portion of the opposing mold half to form a slot for pinching a central portion of a parison between the mold halves but not severing the parison,

a tail puller mechanism on each of said mold halves for grasping a tail portion of the parison that extends from said slot between said mold halves, and

means for actuating said tail puller mechanisms when said mold halves are closed to grasp and pull the parison tail portion extending from said slot, and thereby sever the tail portion from the parison, to leave an atmospheric vent in the bottom of the container formed between the mold halves corresponding to the geometry of said slot.

16.

The apparatus set forth in claim 15 further comprising a combined blow pin and cutter having a configuration for blowing a parison in said cavity, shaping a flange on the parison, and cutting a moil from the parison to provide a finished container.

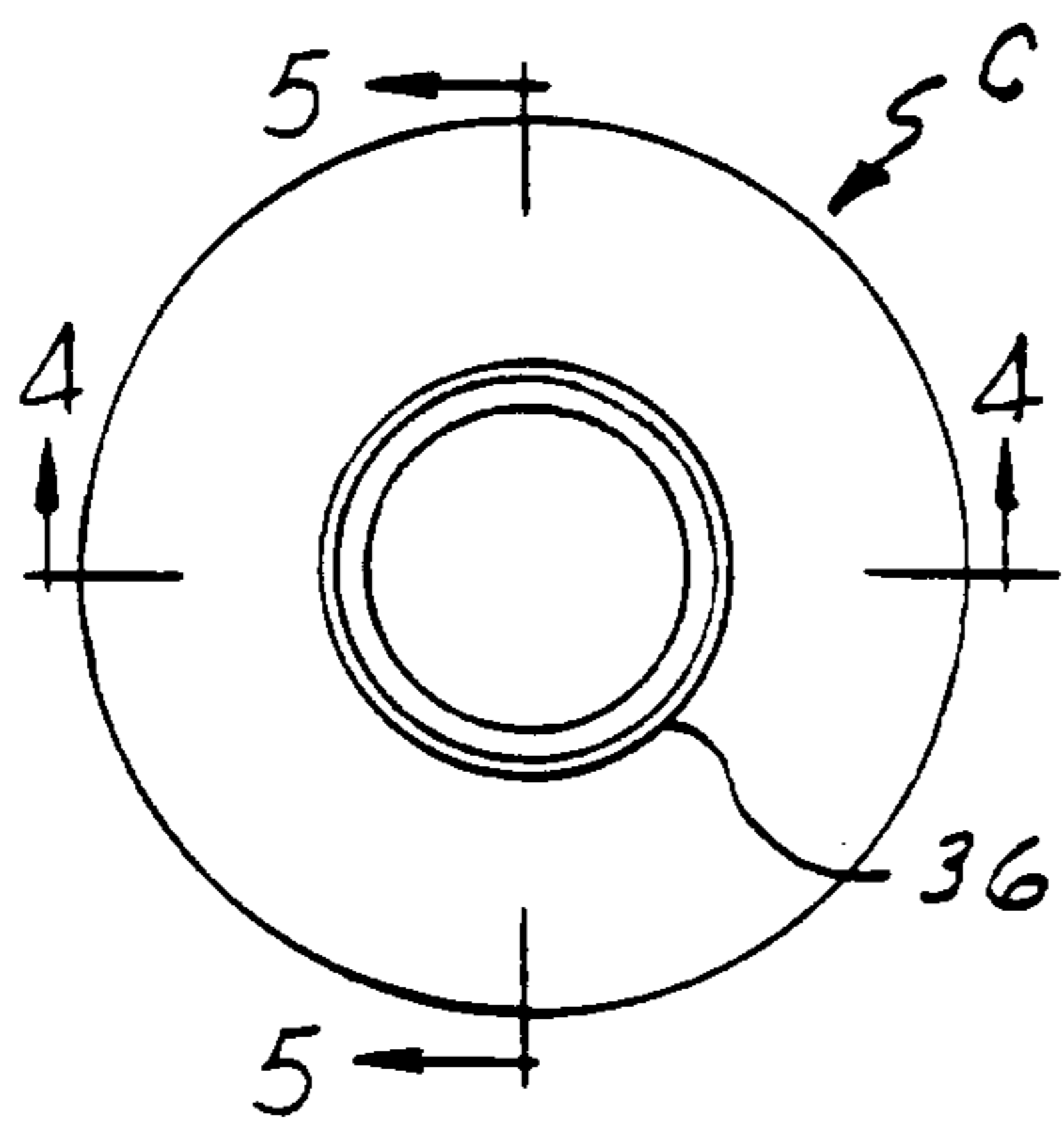

FIG. 2

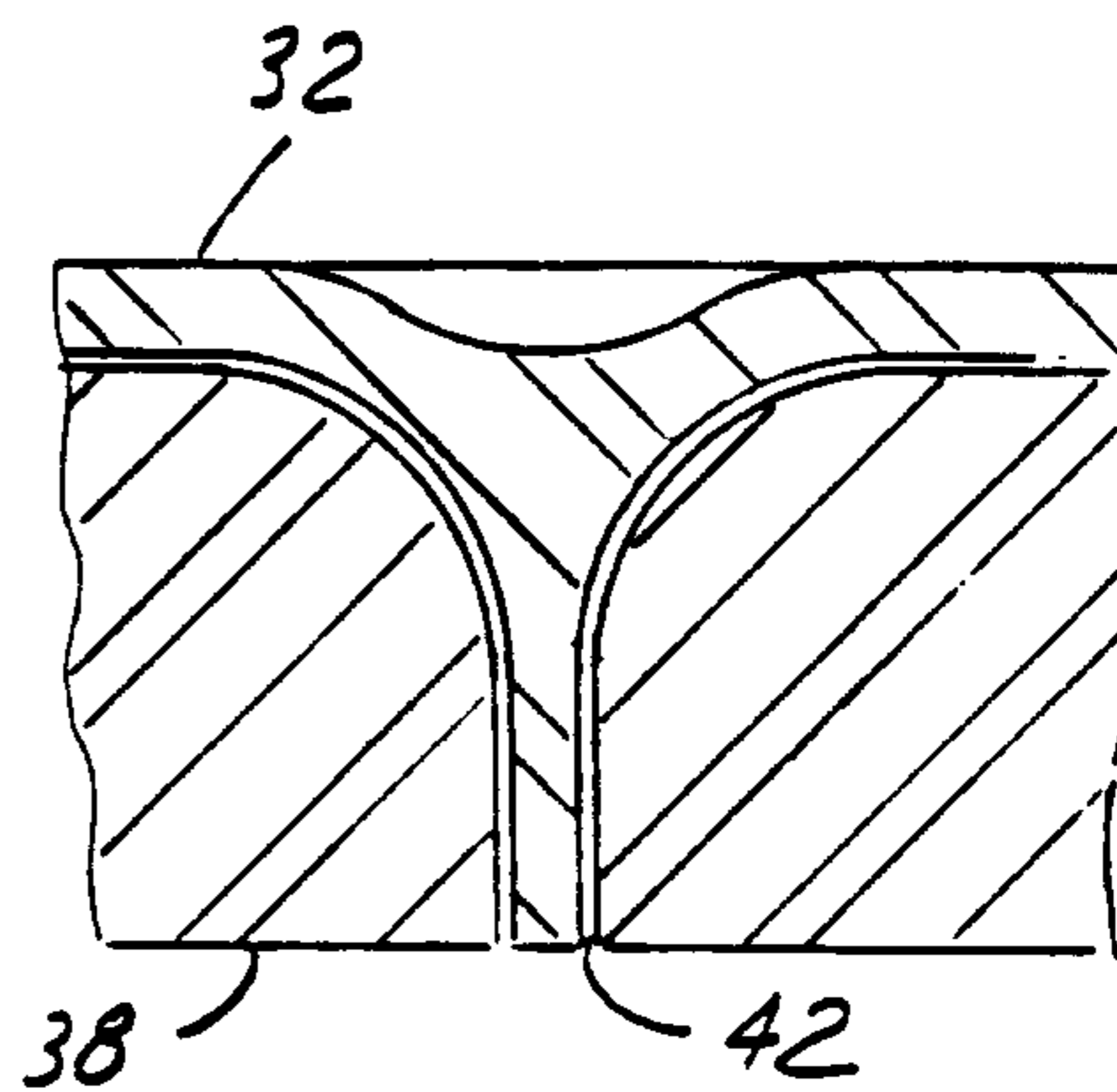

FIG. 5A

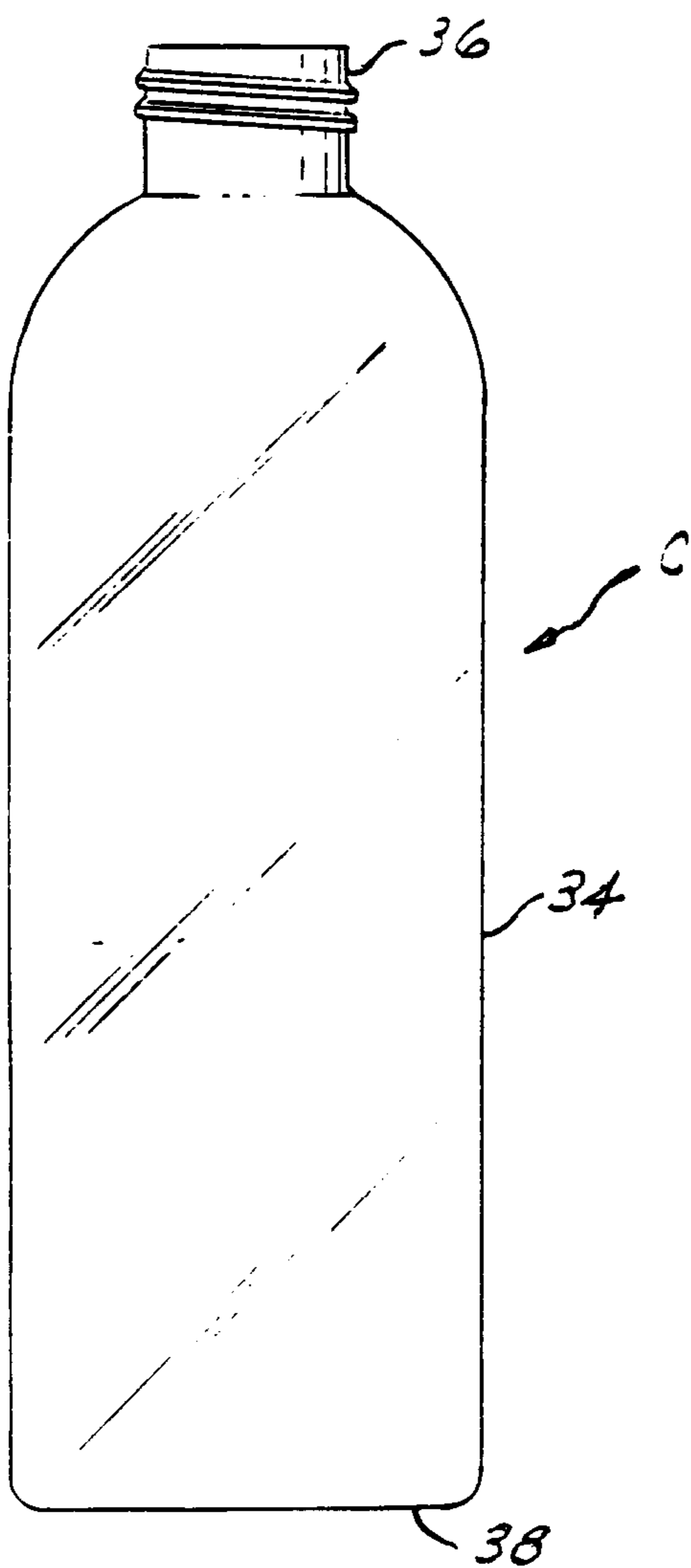

FIG. 1

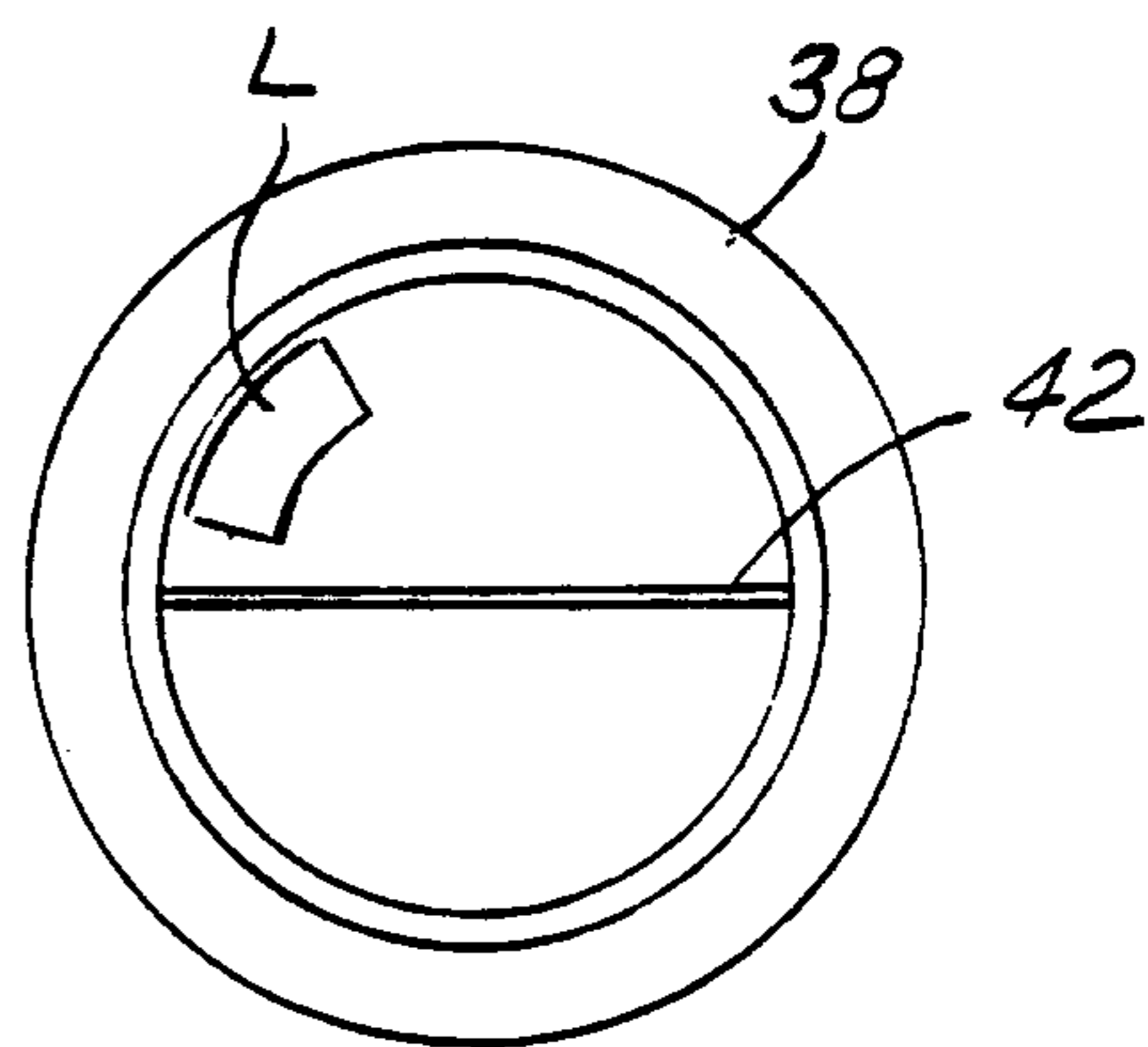
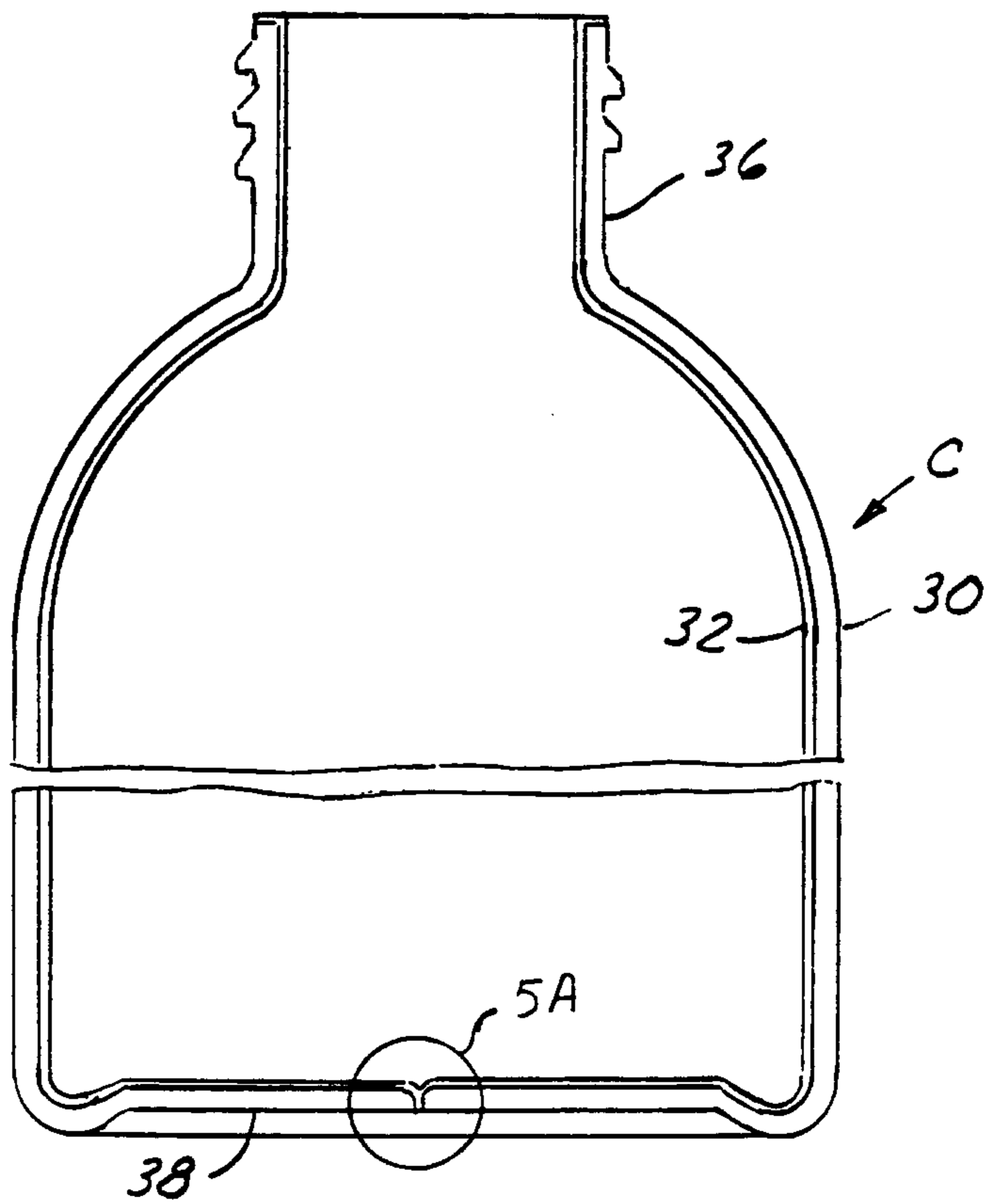
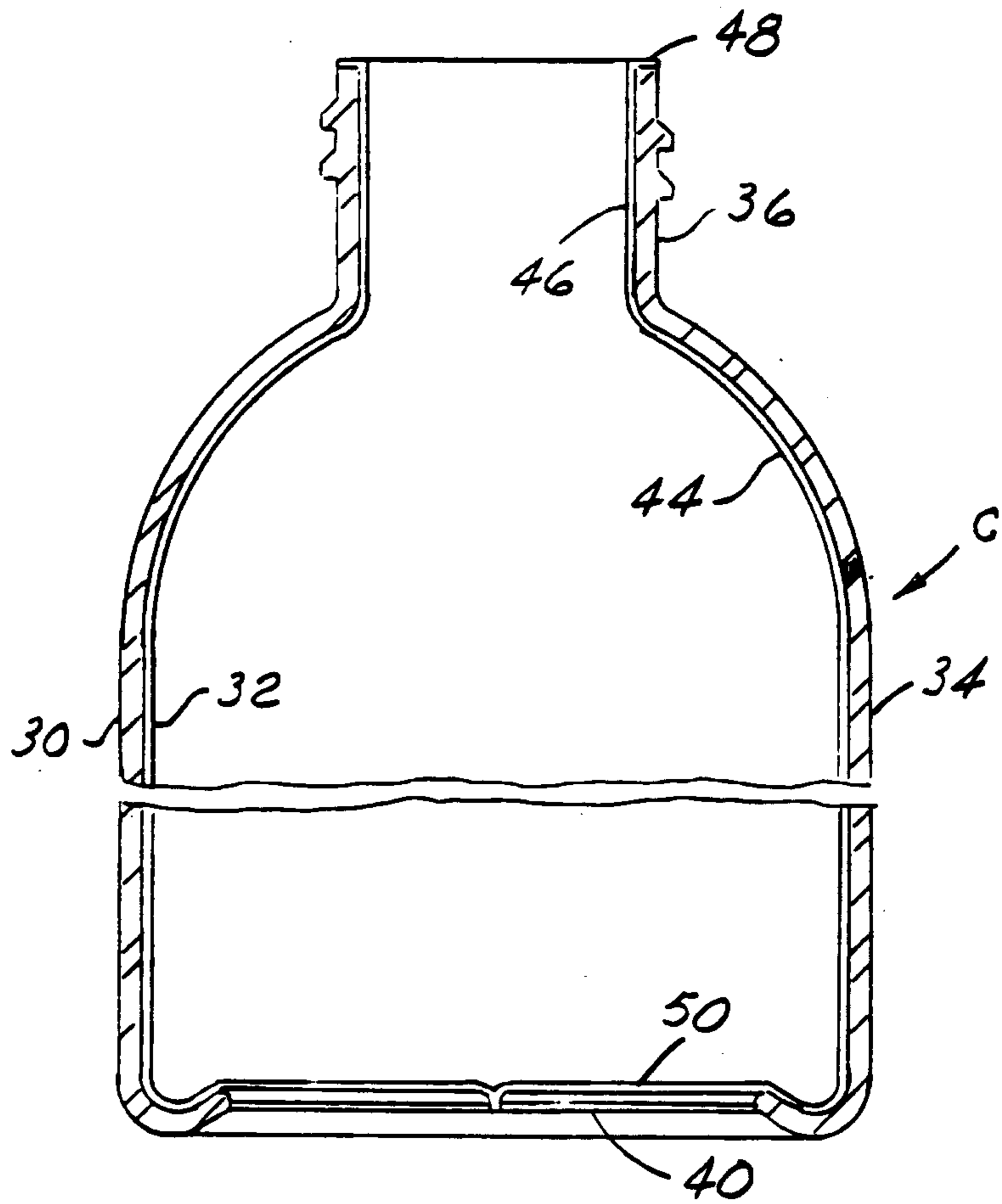

FIG. 3



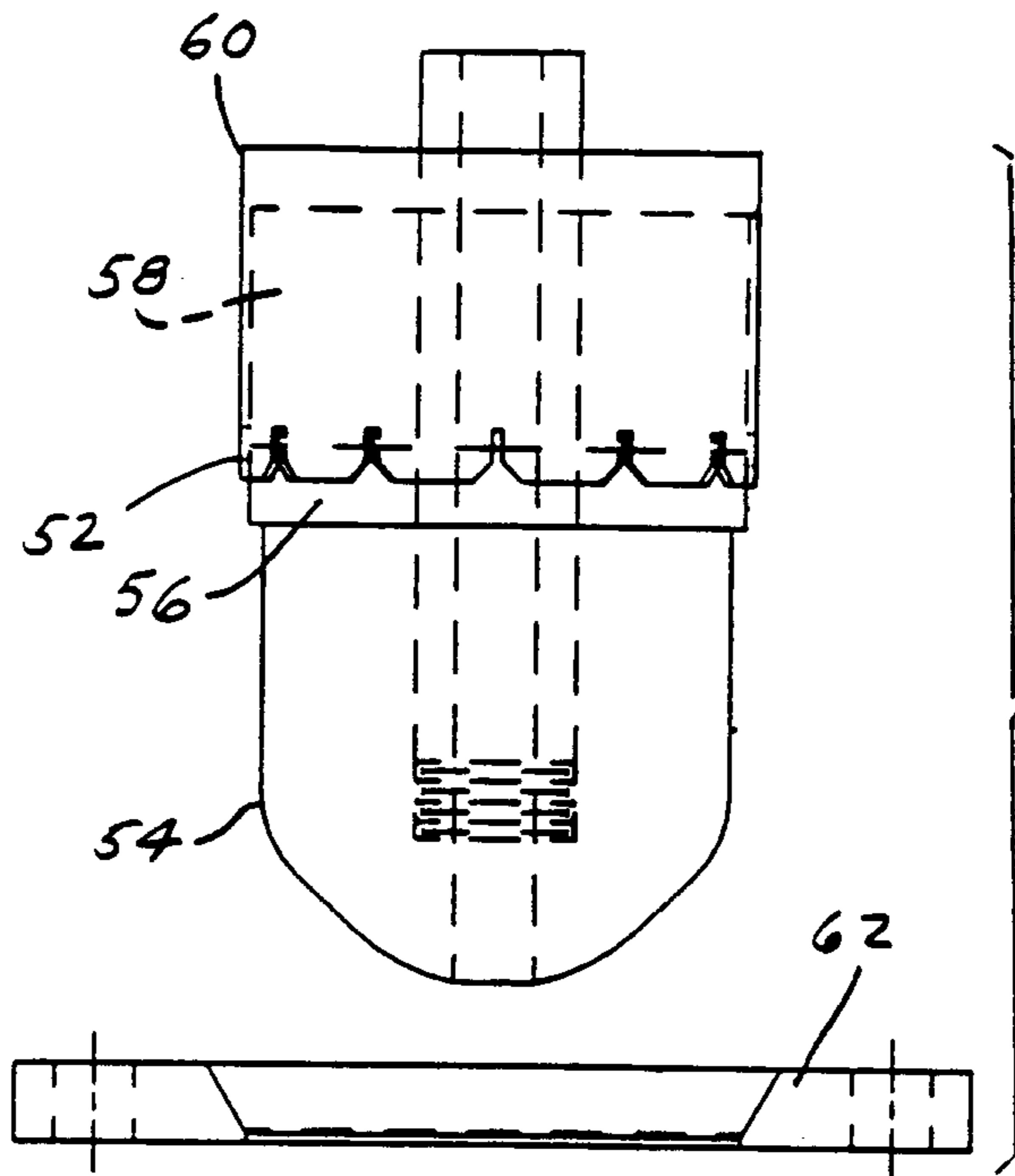

FIG. 6

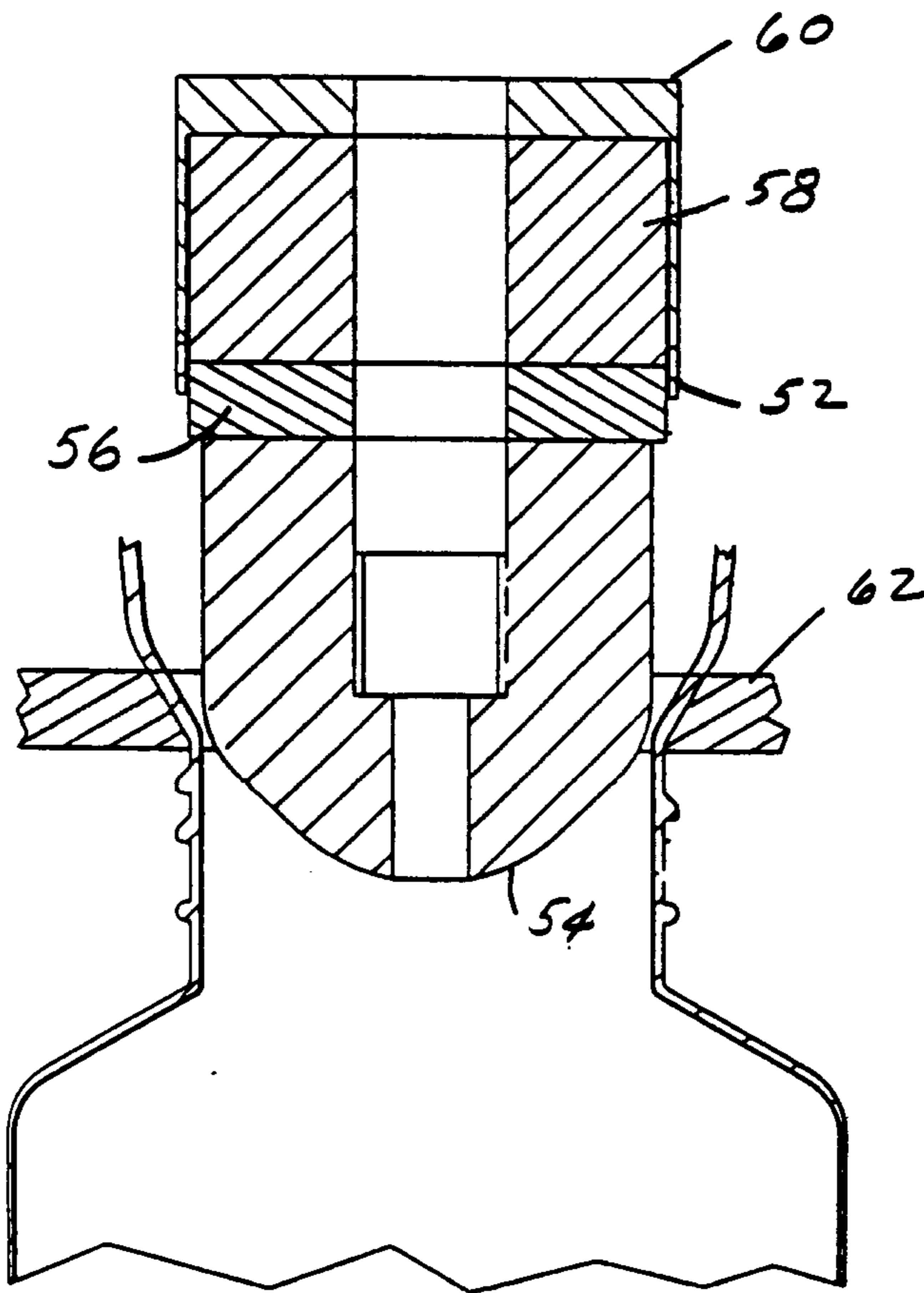

FIG. 7

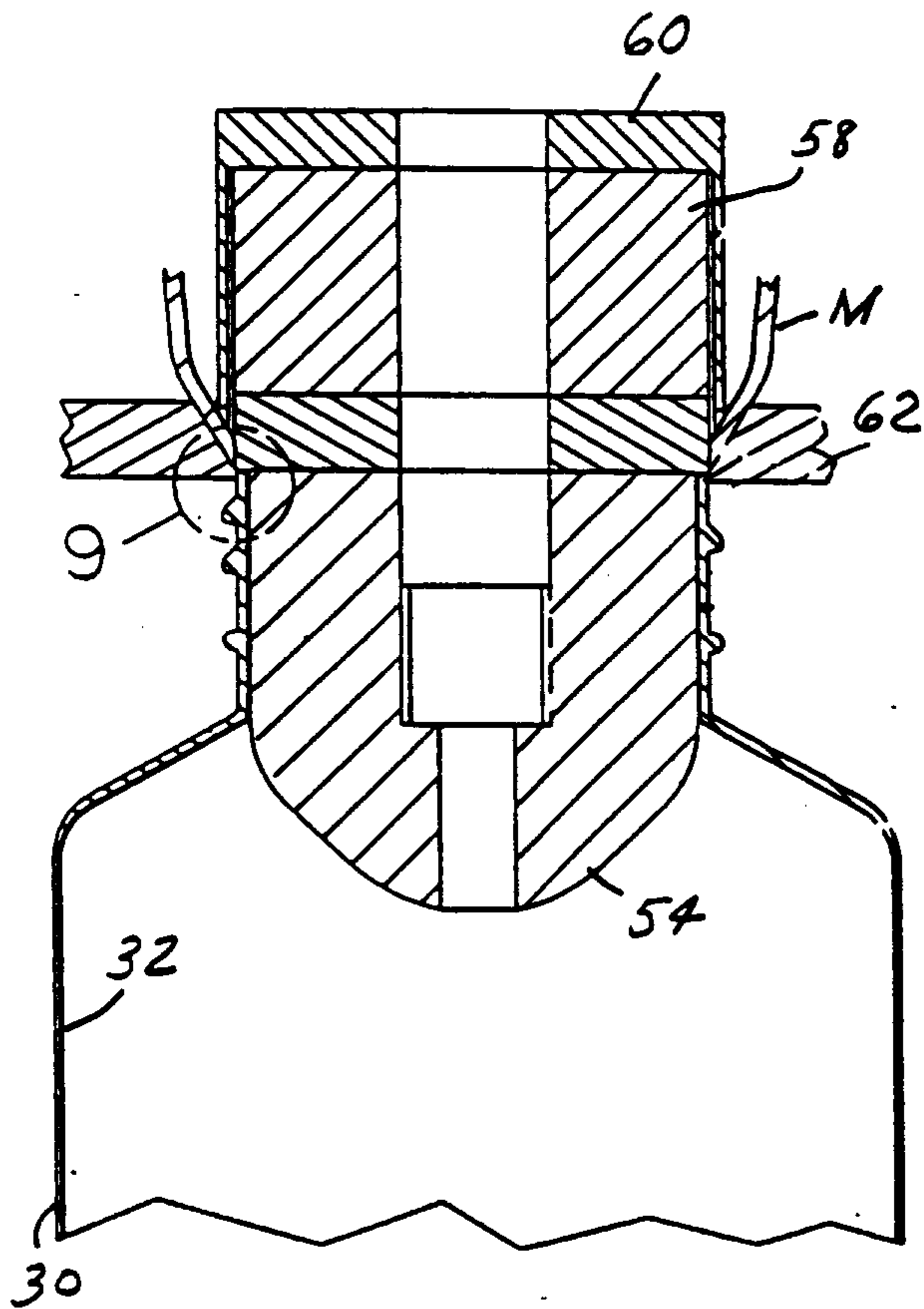

FIG. 8

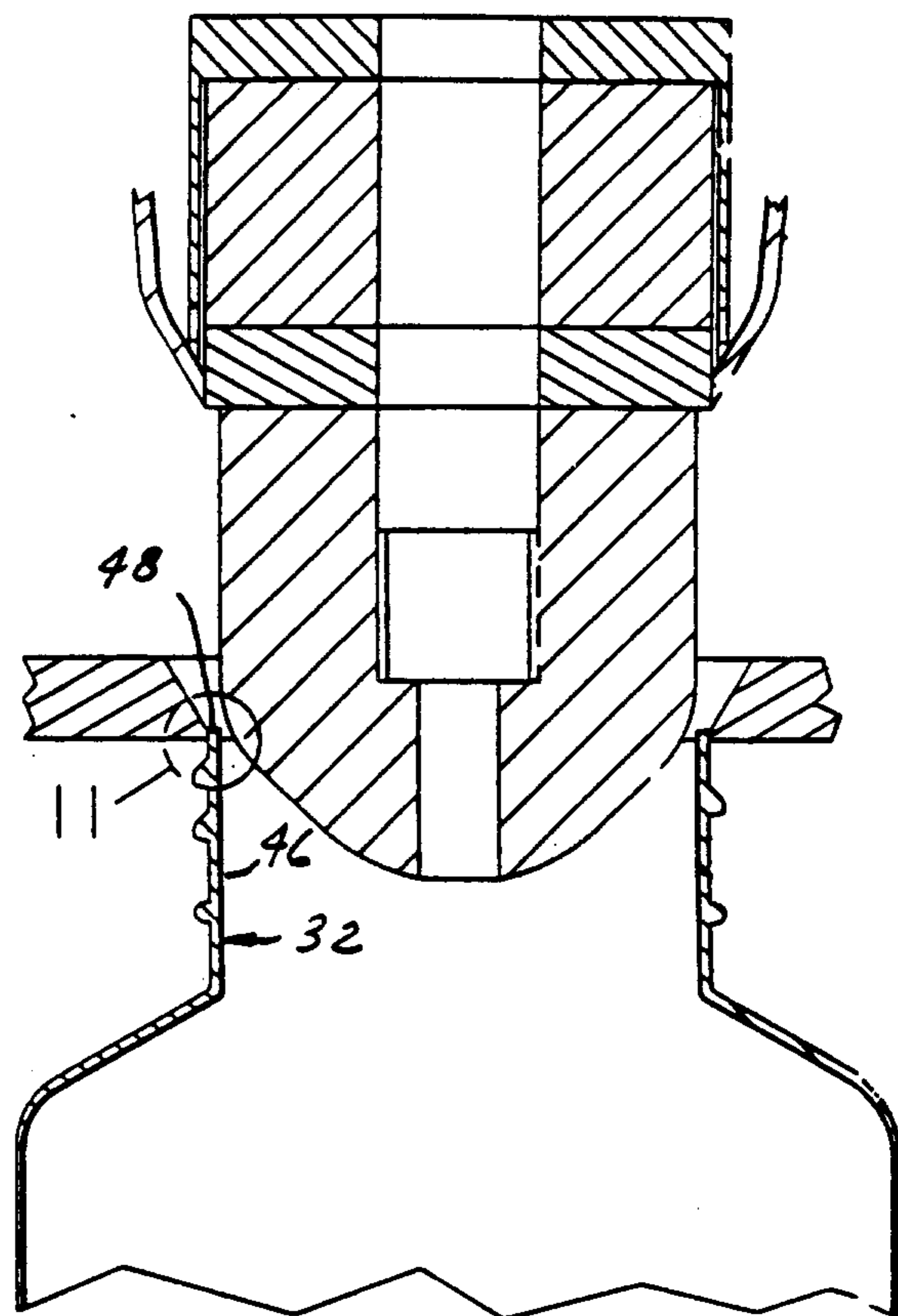

FIG. 10

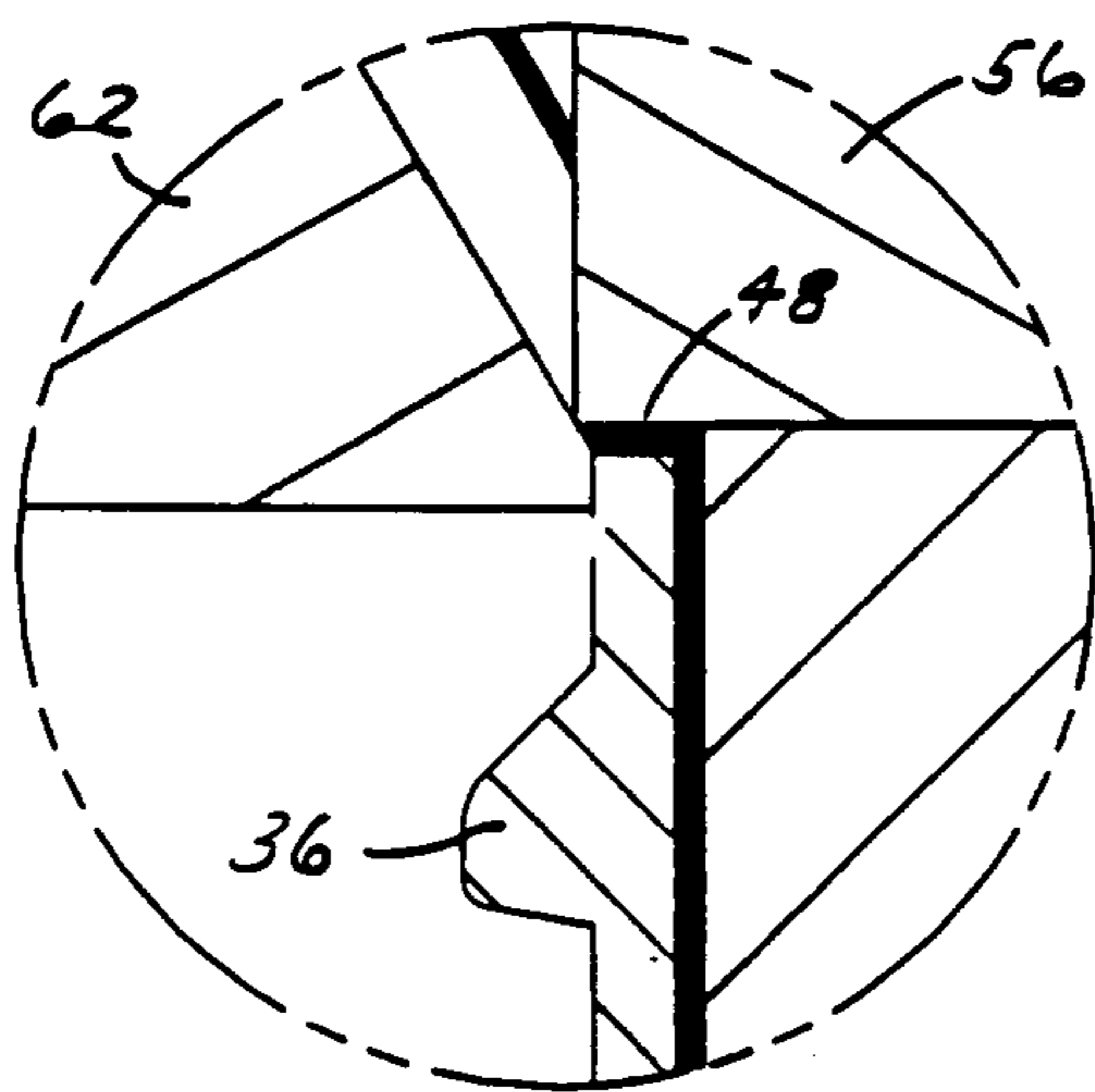

FIG. 9

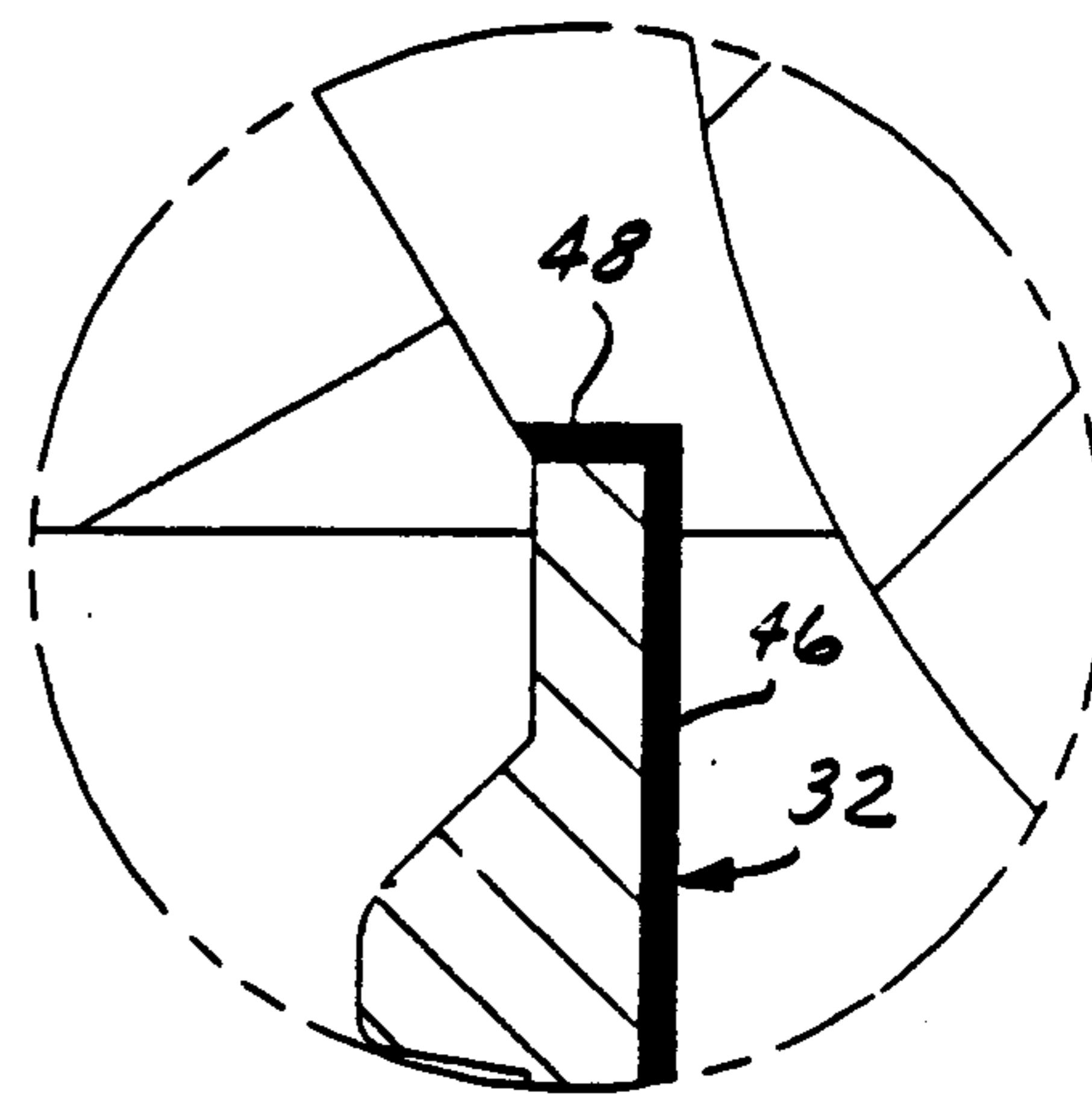
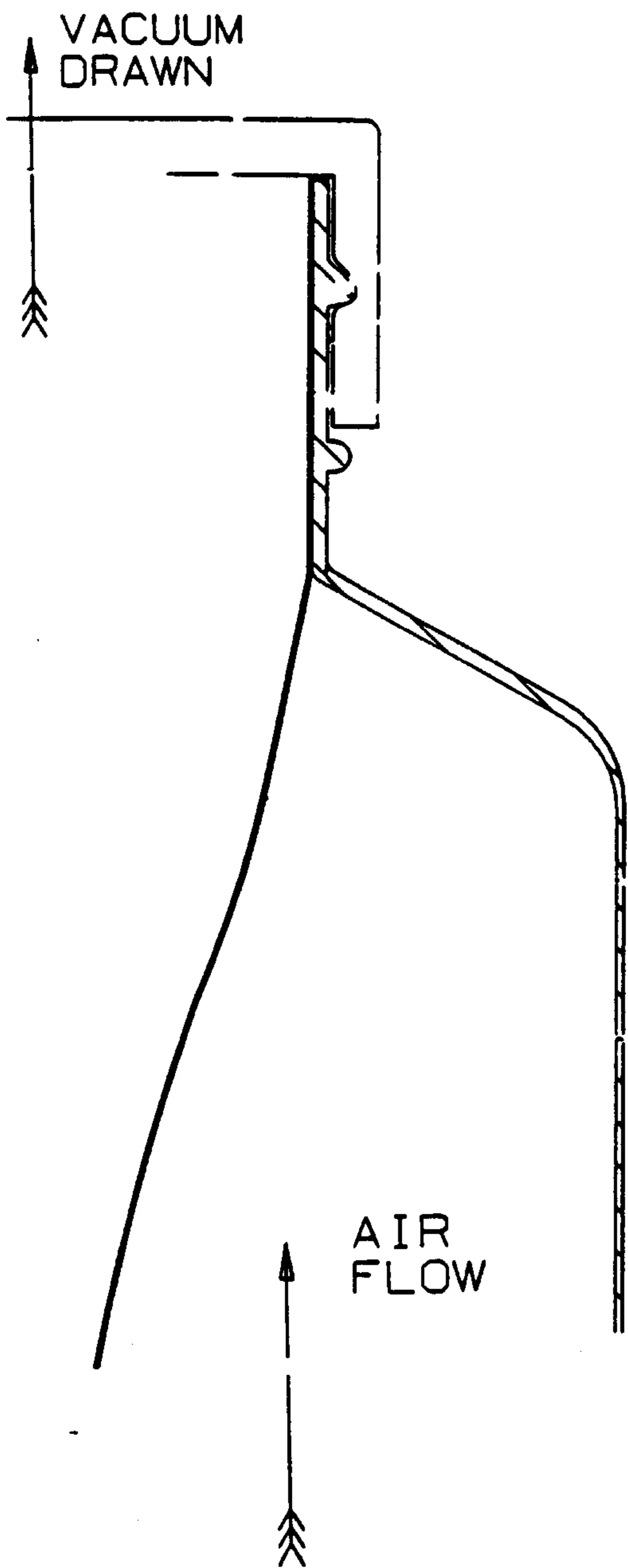
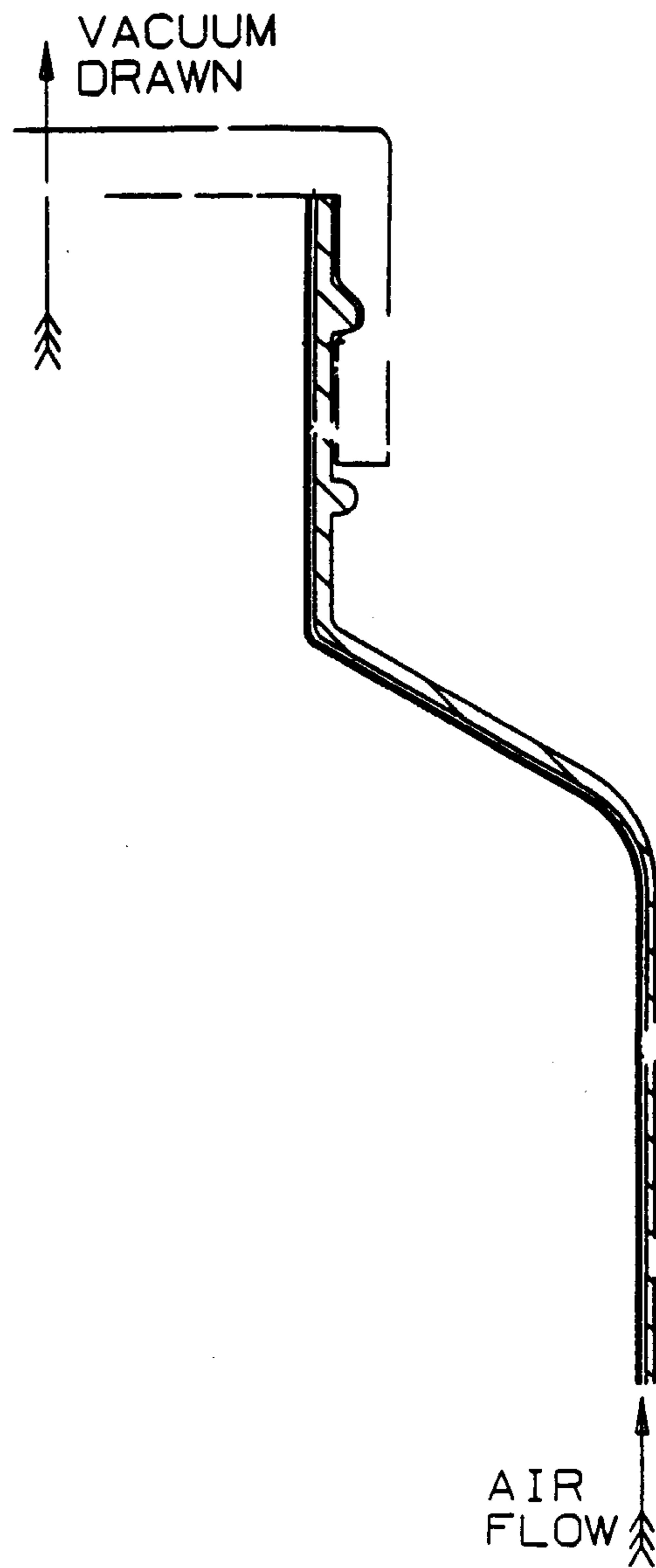

FIG. 11



WITH FLANGE

FIG.12



WITHOUT FLANGE

FIG.13

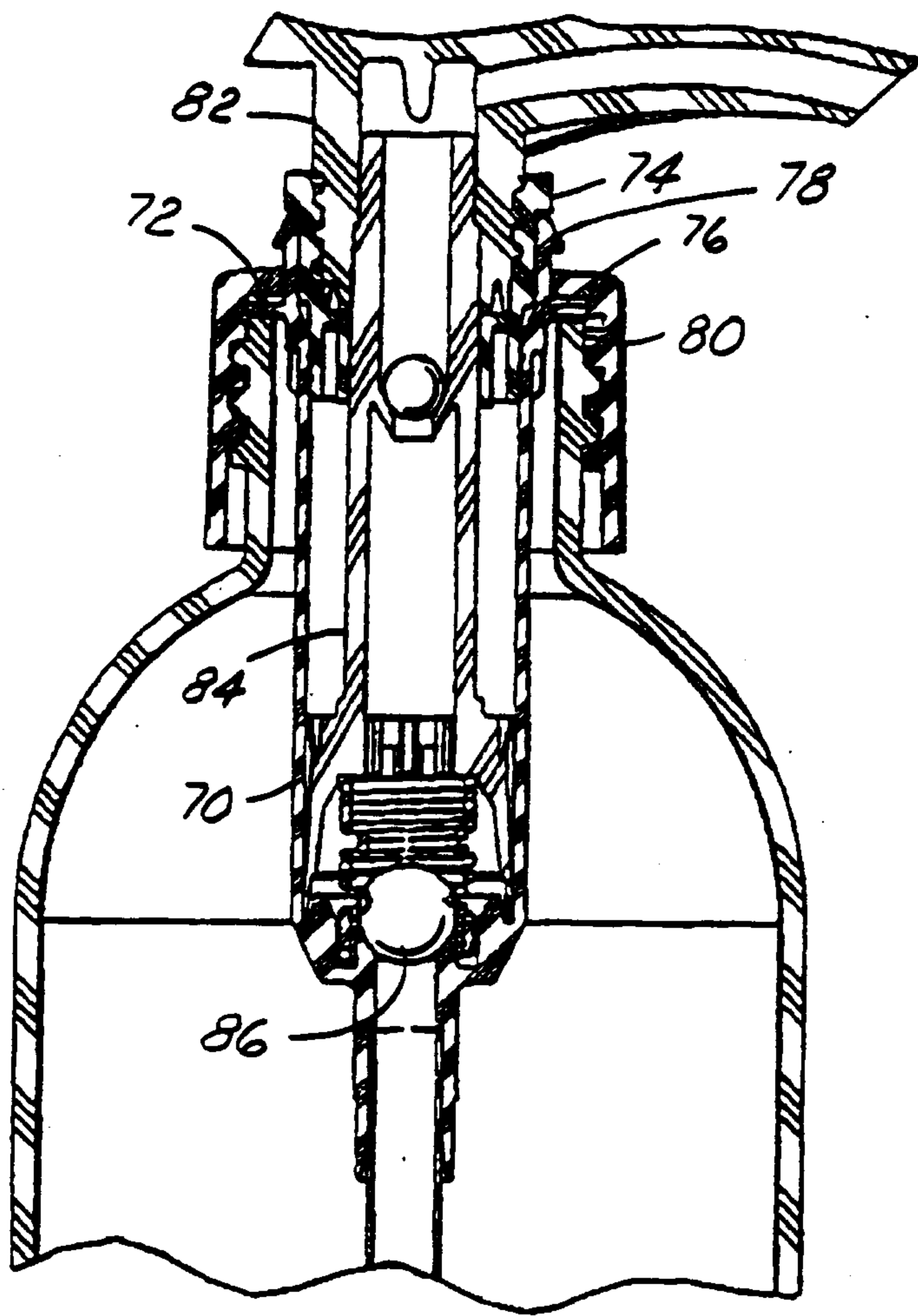

FIG. 14

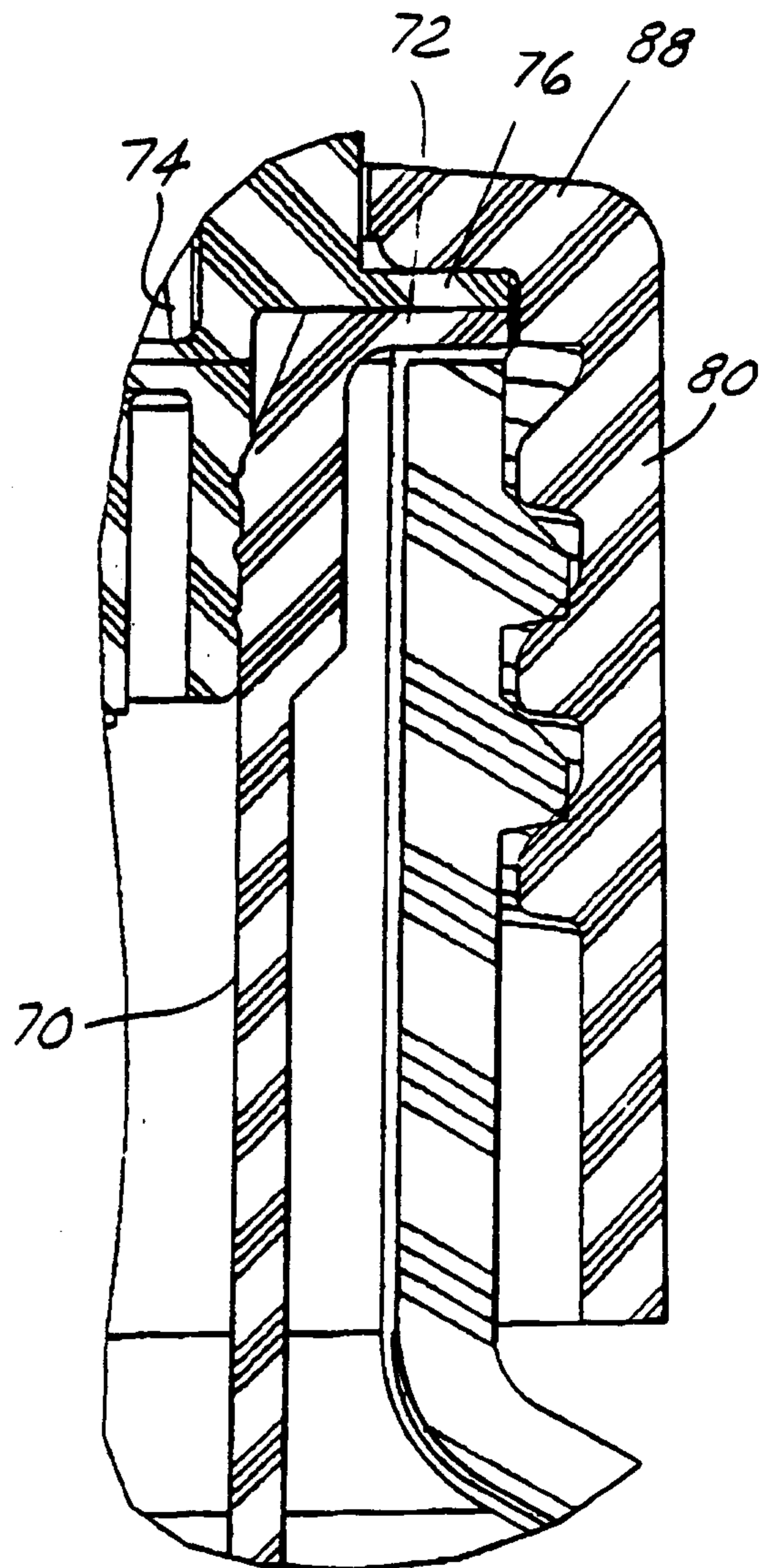
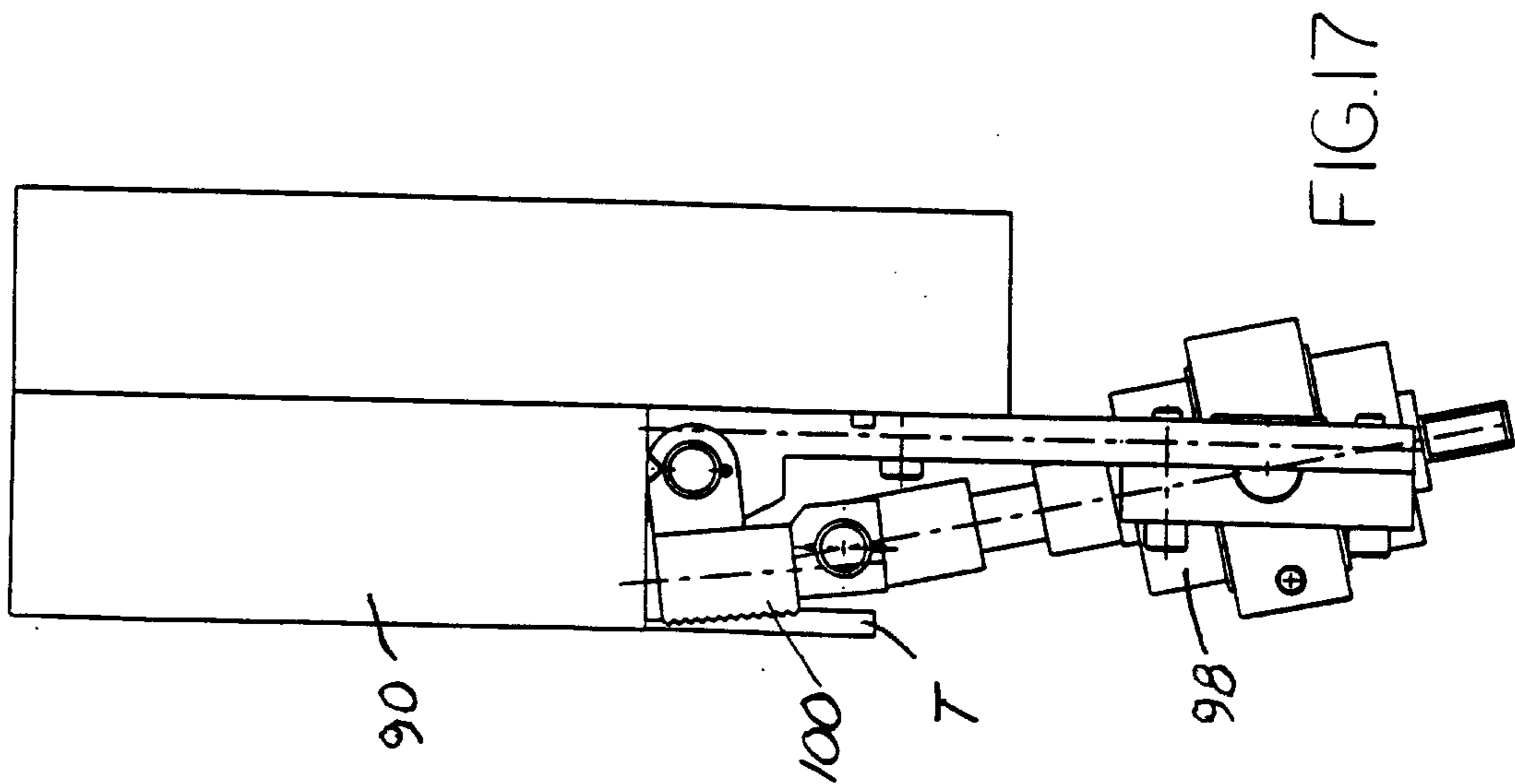
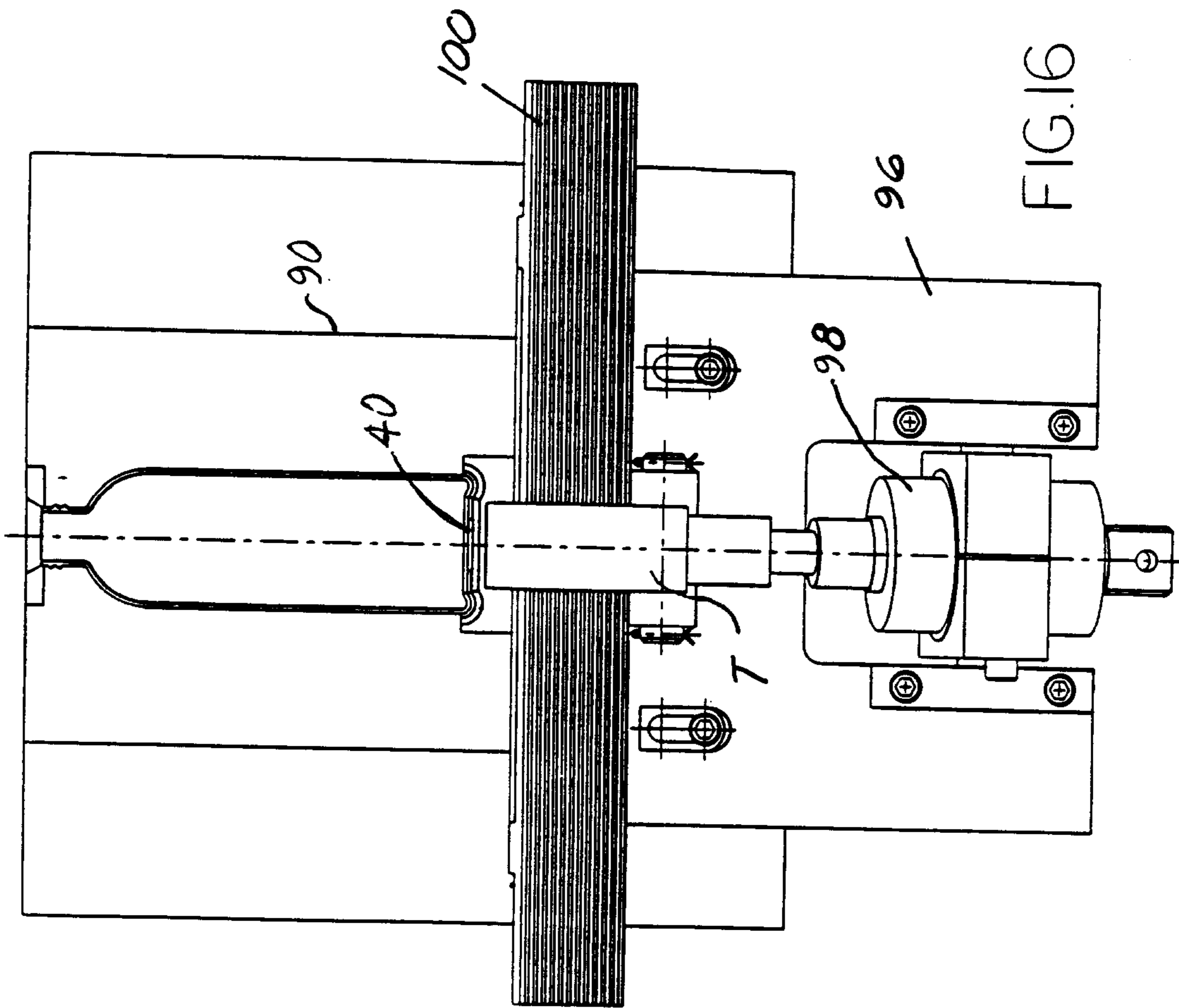

FIG. 15



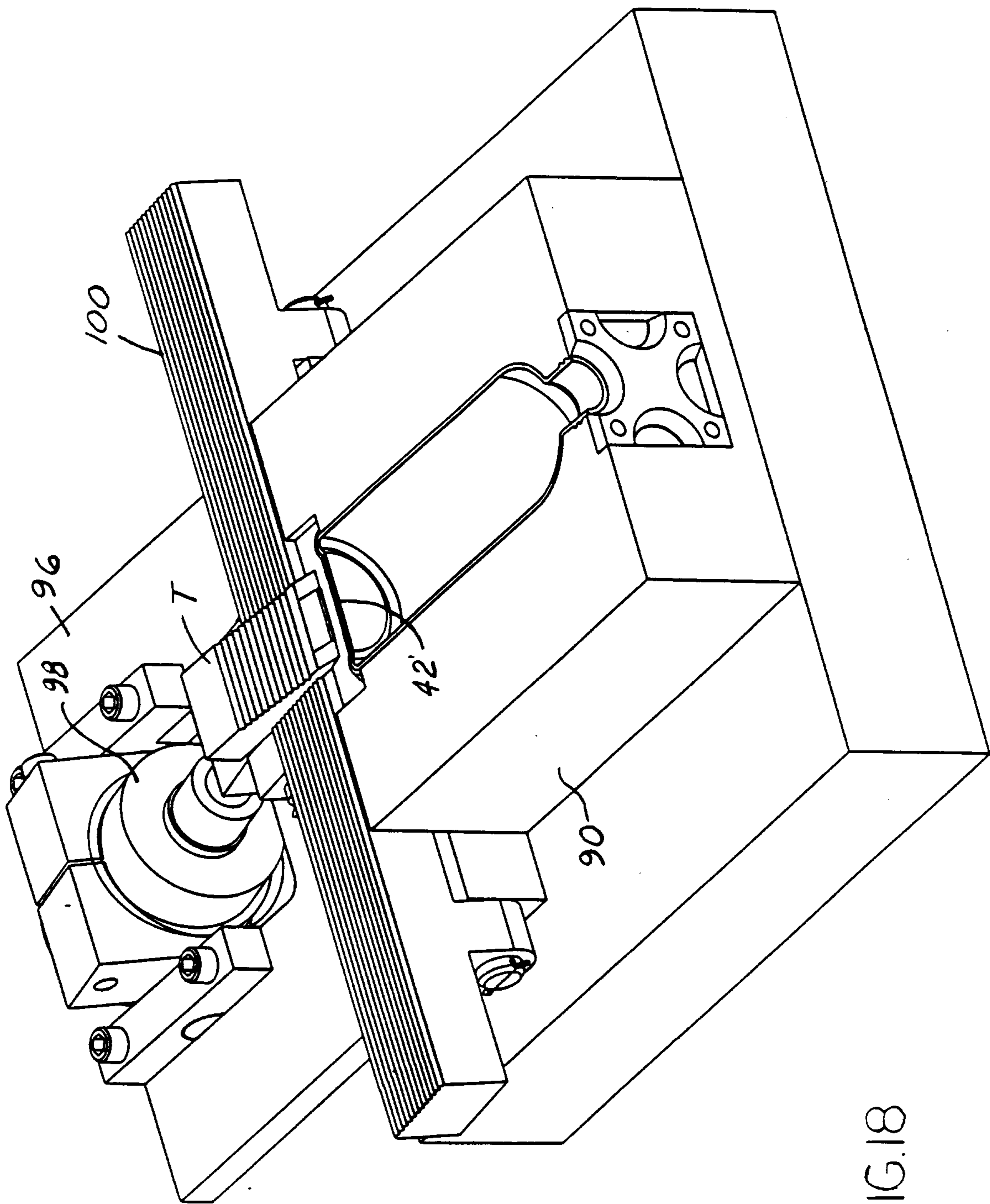

FIG.18

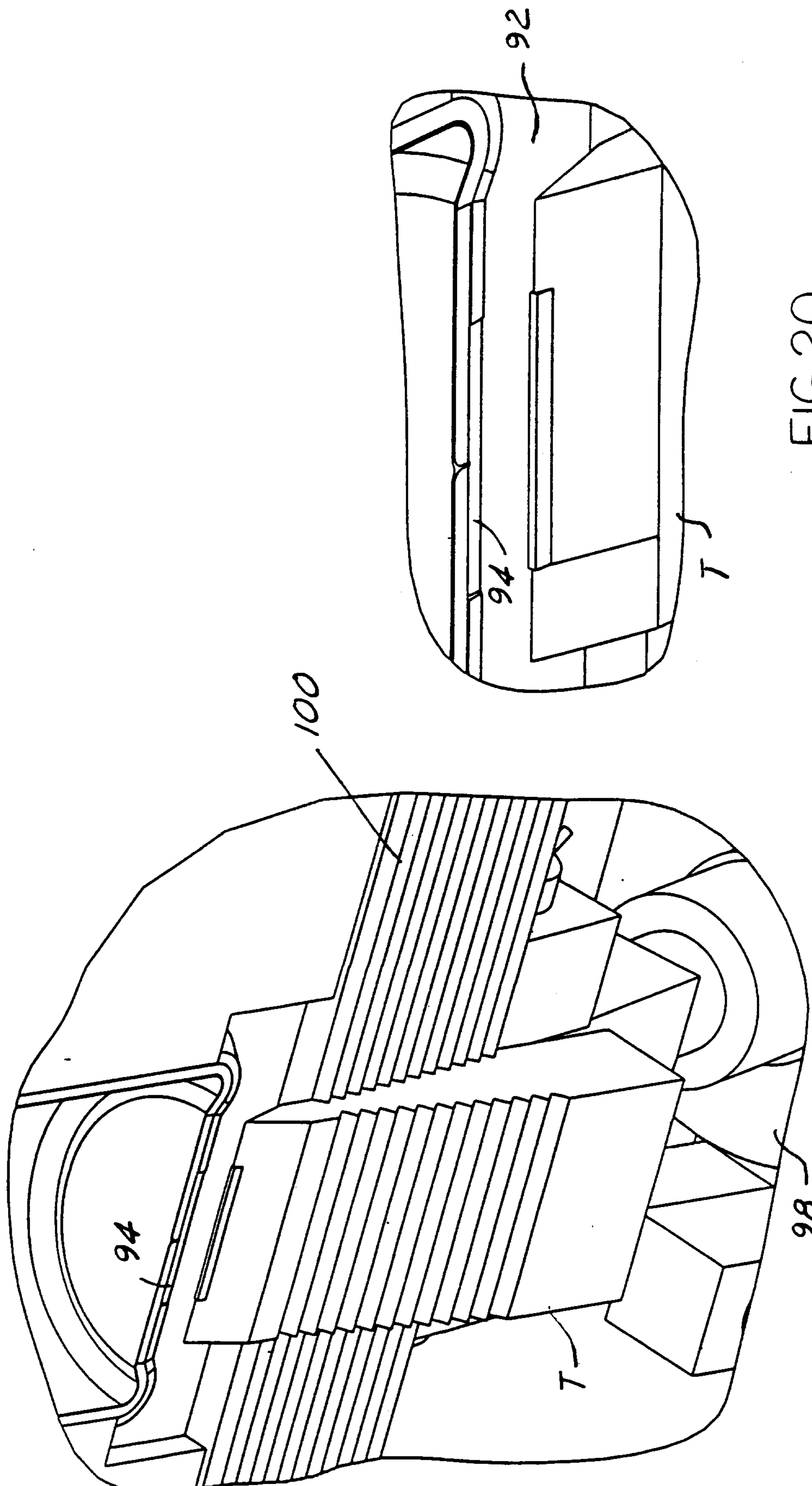

FIG.20

FIG.19

