

July 6, 1948.

E. TAMBINI

2,444,760

SANDING DEVICE

Filed March 21, 1946

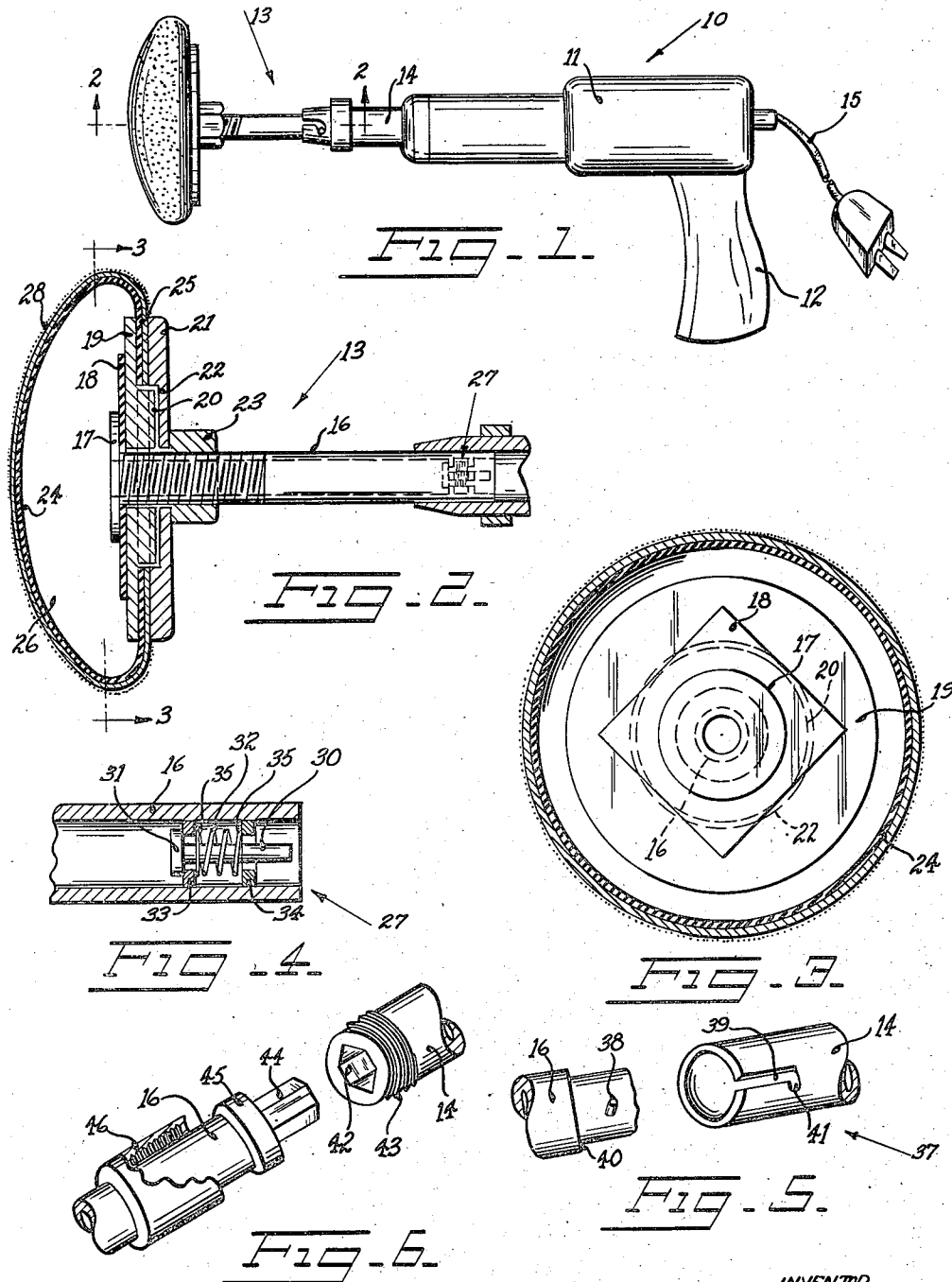

INVENTOR
EUGENE TAMBINI
BY *Gottlieb Holachek*
ATTORNEY

UNITED STATES PATENT OFFICE

2,444,760

SANDING DEVICE

Eugene Tambini, Milford, Conn.

Application March 21, 1946, Serial No. 655,958

1 Claim. (Cl. 51—196)

1

This invention relates in general to a surfacing device and in particular to a surfacing device adapted for polishing, buffing, sanding, scraping and the like.

It is an object of this invention to provide a new surfacing device.

It is another object of this invention to provide a new surfacing device adapted for convenient and easy use in various surface finishing operations.

It is a further object of this invention to provide a small, portable, hand controlled and power operated surfacing device for rapid and convenient surface finishing processes.

Additional objects of this invention as well as its construction, use and operation will in part be obvious and will in part become apparent from the following disclosure.

For further comprehension of the invention, and of the objects and advantages thereof, reference will be had to the following description and accompanying drawings, and to the appended claim in which the various novel features of the invention are more particularly set forth.

In the accompanying drawing forming a material part of this disclosure:

Fig. 1 is a perspective view of a surfacing device according to one form of this invention.

Fig. 2 is a side cross section of the head of the article shown in Fig. 1 taken along line 2—2.

Fig. 3 is a front cross section of the article shown in Fig. 2 taken along the line 3—3.

Fig. 4 is an enlarged fragmentary side cross section of a valve arrangement shown in Fig. 2.

Fig. 5 is a fragmentary exploded perspective view of a mounting means according to one form of this invention for portably mounting the head of the device to the body and driving means.

Fig. 6 is an enlarged exploded perspective view of another means for mounting the head and the body and driving means.

Referring to the figures in detail, there is shown in Fig. 1 a portable surfacing device generally designated 10, comprising a body or housing 11, having a handle 12, and having a head 13 operably positioned at one end thereto, as will be hereinafter described. Within housing 11 there is a power driving means such as, a conventional electrical motor (not shown in the figures) which is adapted to rotate a shaft 14 extending from the front of the housing 11, the motor being operably connected to this shaft by conventional means such as a series of gears which likewise are not shown in the figures. The power is sup-

2

plied to the motor through an electric cord 15 or the like.

In Fig. 2 there is shown a construction and arrangement of the head 13 referred to in connection with Fig. 1. This head 13 comprises a hollow shaft 16 adapted to be mounted on shaft 14 as will be described hereinafter. The front portion of shaft 16 is threaded to receive other parts comprising a head assembly, and at the front end of shaft 16 is mounted a disc 17 which acts as a stop to hold together the head assembly. Disc 17 has a hole through its center aligned with the hollow in shaft 16 so that a direct air passage is provided running through shaft 16 and disc 17.

At the front end of shaft 16 and bearing against disc 17 is a flexible washer 18, and adjacent thereto and bearing against washer 18 is a generally circular clamping plate 19 which has a projecting portion 20 mounted on its rear face. Positioned behind plate 19 is a second generally circular clamping plate 21 having in its front surface a recess 22 to receive projection 20. Behind plate 21 is a nut 23, operably engaging the threaded portion of shaft 16, and adapted to bear against plate 21 thereby tightening the entire assembly disc 17, washer 18 and plates 19 and 21.

A flexible bag 24 is adapted to be positioned on the above described head assembly and comprises a thin flexible sheet material in bag-like form having an open end 25 which is adapted to be placed between and received between plates 19 and 21. When bag 24 is so mounted, it will be seen that there is an air space or chamber 26 contained within the bag in front of the previously described head assembly. By the coaction of bag 24, disc 17, washer 18 and plate 19, the chamber 26 is thoroughly sealed except for the hollow leading through disc 17 and shaft 16. A valve arrangement 27 at the other end of shaft 16 completes the sealing off of chamber 26 so that this becomes a thoroughly sealed air pocket.

In Fig. 3 there is shown the arrangement described in Fig. 2 from a front view wherein the interrelationship between the various parts may in some cases be more clearly seen. The articles shown therein are the same as those shown in Fig. 2 and further description is unnecessary.

The head assembly 13 is interchangeably transformed into one of a number of surfacing devices by placing a sheet 28 of a surfacing material around bag 24 and securing the ends of the surfacing sheet 28 between plates 19 and 21. In this way, by interchanging sheet 28 among such sheet material as, for example, sand paper,

3

emery paper, emery cloth, polishing cloth and the like, a number of different surfacing heads may be produced from the same general head assembly 13, whereby the device is interchangeably adapted for numerous purposes.

In Fig. 4 there is shown one of numerous simple valve arrangements 27, whereby compressed air or the like may be releasably introduced into chamber 26 through shaft 16. This valve arrangement 27 comprises a plunger pin 30 having a head 31 at its forward end, and being mounted by means of spring 32 between the pair of shoulders 33 and 34 mounted within and adjacent to the end of shaft 16. Spring 32 optionally is mounted on plunger pin 30 by means of a pair of discs 35 which are not airtight, and accordingly permit the passage of air therearound. When pin 30 is depressed, head 31 is forced away from shoulder 33 whereby air or other fluid may be forced through shaft 16. When pin 30 is released, spring 32 operates to force head 31 against shoulder 33 whereby the passage through shaft 16 is closed. It is noted that the pressure of a fluid within chamber 26 will normally tend to close this valve assembly.

In Fig. 5 there is shown one mounting arrangement generally designated 37 comprising a small projecting pin 38 on the end of shaft 16 adapted to releasably engage a slot 39 in shaft 14 when shaft 16 is inserted into the open hollow end of shaft 14. Preferably, the end 41 of slot 39 is bent at right angles to the direction of shafts 14 and 16 whereby pin 38 will be locked in position therein. Also and optionally, a shoulder 40 near the end of shaft 16 is adapted to bear against the end of shaft 14 when it is properly inserted therein.

According to the arrangement shown in Fig. 5 it will be understood that the end 41 of slot 39 will be so directed that the reaction of the power operation of the device will tend to tighten pin 38 in slot 39 rather than to loosen it. Whereby the operation of the device tends to secure head 13 in shaft 14 rather than to loosen it.

In Fig. 6 there is shown another mounting means between shaft 16 and shaft 14 wherein there is provided a positive locating means. In this form of the invention, the end of shaft 14 is hollow in an angular structure, for example, a hexagonal formation 42. Adjacent this bent end of shaft 14 is a threaded portion 43. The end of shaft 16 has an angular projection 44, such as a hexagonal projection adapted to engage hollow 42 in shaft 14. A collar or shoulder 45 adjacent this projection bears against the end of shaft 14, and an internally threaded nut 46 positioned around shaft 16 is adapted to engage the threaded portion 43 of shaft 14 and to bear against collar 45, thereby securely clamping together shaft 16 and shaft 14. The angular formation of projection 44 and hollow 42 insures a positive driving means between the shafts and the threaded connection between nut 46 and threaded portion 43 insures a secure interconnection between the shafts.

In the use of this invention, the suitable head assembly, such as a head 13, shown in Fig. 2 and equipped with a sheet 28 of sand paper, is inflated by means of compressed air passed through shaft 16 or the like. This assembly is then connected to shaft 14, as shown in Figs. 5 or 6,

4

and the power is connected whereby head 13 is rapidly rotated.

The device is then used for a sanding operation by the simple process of holding the device by handle 12 and directing head 13 against the surface to be sanded.

It will be understood that there may be used various heads having different grades of finishing material or, if desired, finishing materials of entirely different type so that the device may be used for numerous finishing operations in rapid succession merely by replacing one assembly head with another head.

The device is useful for numerous operations such as, waxing, polishing, buffing, sanding, paint removing and the like on metal or wood construction surfaces, various household surfaces, automobiles, boats and other articles of numerous description.

While I have illustrated and described the preferred embodiments of my invention, it is to be understood that I do not limit myself to the precise constructions herein disclosed and the right is reserved to all changes and modifications coming within the scope of the invention as defined in the appended claim.

Having thus described my invention, what I claim as new, and desire to secure by United States Letters Patent is:

In combination with a portable power-driven shaft and coupling element on its outer end, of a buffing head detachably coupled with said shaft, said buffing head comprising an axially hollow shaft having screw threads adjacent one end thereof, a coupling member and a valve adjacent the other end thereof, said valve being disposed inside said hollow shaft for closing the shaft with respect to air passing outwardly thereof, a disc mounted on said threaded end of said shaft supporting a clamping plate, a flexible pneumatic bag supported upon said plate, an abrasive member supported upon said bag, a second clamping plate, the edges of the bag and abrasive member being positioned between said clamping plates and retained in position therebetween, a clamping nut on said threaded portion of the shaft for pressing the clamping plates together to sealingly hold said bag and abrasive member upon the end of said shaft, whereby said buffing head may be inflated to a predetermined pressure before being coupled to the power-driven shaft, said valve maintaining said pressure during normal use of said buffing head.

EUGENE TAMBINI.

REFERENCES CITED

The following references are of record in the file of this patent:

UNITED STATES PATENTS

Number	Name	Date
849,338	Rogers	Apr. 2, 1907
1,138,926	Bernett	May 11, 1915
1,279,996	Dorland	Sept 24, 1918
1,479,583	Carey	Jan. 1, 1924
1,656,182	Enna	Jan. 17, 1928
1,966,521	Ricks	July 17, 1934

FOREIGN PATENTS

70 Number	Country	Date
23,394	Great Britain	1904