

(19) World Intellectual Property
Organization
International Bureau



(43) International Publication Date
21 July 2005 (21.07.2005)

PCT

(10) International Publication Number
WO 2005/067212 A1

(51) International Patent Classification⁷: H04L 12/28,
12/56

[JP/JP]; c/o SONY CORPORATION, 7-35, Kitashinagawa
6-Chome, Shinagawa-Ku, Tokyo, 1410001 (JP).

(21) International Application Number:
PCT/JP2004/017437

(74) Agents: YAMADA, Eiji et al.; Sawada, Miyata & Yamada
Patent Office, Ginza TK Bldg., 1-7, Shintomi 1-chome,
Chuo-ku, Tokyo, 1040041 (JP).

(22) International Filing Date:
17 November 2004 (17.11.2004)

(81) Designated States (unless otherwise indicated, for every
kind of national protection available): AE, AG, AL, AM,
AT, AU, AZ, BA, BB, BG, BR, BW, BY, BZ, CA, CH, CN,
CO, CR, CU, CZ, DE, DK, DM, DZ, EC, EE, EG, ES, FI,
GB, GD, GE, GH, GM, HR, HU, ID, IL, IN, IS, KE, KG,
KP, KR, KZ, LC, LK, LR, LS, LT, LU, LV, MA, MD, MG,
MK, MN, MW, MX, MZ, NA, NI, NO, NZ, OM, PG, PH,
PL, PT, RO, RU, SC, SD, SE, SG, SK, SL, SY, TJ, TM, TN,
TR, TT, TZ, UA, UG, US, UZ, VC, VN, YU, ZA, ZM, ZW.

(25) Filing Language: English

(26) Publication Language: English

(30) Priority Data:
2004-003530 8 January 2004 (08.01.2004) JP
2004-196837 2 July 2004 (02.07.2004) JP
10/910,646 4 August 2004 (04.08.2004) US

(84) Designated States (unless otherwise indicated, for every
kind of regional protection available): ARIPO (BW, GH,
GM, KE, LS, MW, MZ, NA, SD, SL, SZ, TZ, UG, ZM,
ZW), Eurasian (AM, AZ, BY, KG, KZ, MD, RU, TJ, TM),
European (AT, BE, BG, CH, CY, CZ, DE, DK, EE, ES, FI,
FR, GB, GR, HU, IE, IS, IT, LU, MC, NL, PL, PT, RO, SE,
SI, SK, TR), OAPI (BF, BJ, CF, CG, CI, CM, GA, GN, GQ,
GW, ML, MR, NE, SN, TD, TG).

(71) Applicant (for all designated States except US): SONY
CORPORATION [JP/JP]; 7-35, Kitashinagawa 6-Chome,
Shinagawa-Ku, Tokyo, 1410001 (JP).

(72) Inventors; and

(75) Inventors/Applicants (for US only): MORIOKA, Yuichi
[JP/JP]; c/o SONY CORPORATION, 7-35, Kitashina-
gawa 6-Chome, Shinagawa-Ku, Tokyo, 1410001 (JP).
SAKODA, Kazuyuki [JP/JP]; c/o SONY CORPORA-
TION, 7-35, Kitashinagawa 6-Chome, Shinagawa-Ku,
Tokyo, 1410001 (JP). KURODA, Shinichi [JP/JP]; c/o
SONY CORPORATION, 7-35, Kitashinagawa 6-Chome,
Shinagawa-Ku, Tokyo, 1410001 (JP). SAWAI, Ryo

Published:
— with international search report

For two-letter codes and other abbreviations, refer to the "Guid-
ance Notes on Codes and Abbreviations" appearing at the begin-
ning of each regular issue of the PCT Gazette.

(54) Title: PACKET CONFIGURATION FOR THE COEXISTENCE OF STATIONS IN A MULTISTANDARD WIRELESS LAN

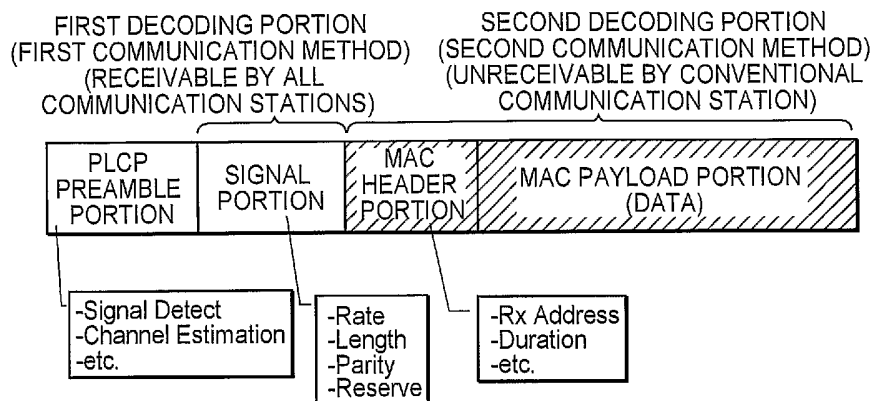

(57) Abstract: Random access operation is performed under a communication environment in which a plurality of communication modes having different transmission rate coexist with small overhead. A high-grade communication station spoofs information of a packet length and a rate in a decoding portion so that a value of (packet length) / (rate) corresponds to a duration where the communication is hoped to be stopped. The other station receiving the spoofed information receives the rest of the packet with the designated rate during the interval designated by the value of (packet length) / (rate). In this case, the packet length and the rate are not those of actually transmitted packet so that this packet is discarded.

WO 2005/067212 A1

DESCRIPTION

PACKET CONFIGURATION FOR THE COEXISTENCE OF STATIONS IN A MULTISTANDARD WIRELESS LAN

5

Technical Field

The present invention relates to a wireless communication system, a wireless communication apparatus, a wireless communication method, and a computer program for performing mutual communication among a plurality of wireless stations like a wireless local area network (LAN). In particular, the present invention relates to a wireless communication system, a wireless communication apparatus, a wireless communication method and a computer program in which each communication station performs random access on the basis of carrier detection in accordance with the carrier sense multiple access with collision avoidance (CSMA) system.

20 To be more precise, the present invention relates to a wireless communication system, a wireless communication apparatus, a wireless communication method and a computer program for realizing random access in a communication environment in which a plurality of communication modes each having a transmission rate different from each other is intermixed. In particular, the present invention relates to a wireless communication system, a wireless communication apparatus, a wireless communication method and a computer program for realizing random access with a smaller overhead under a communication environment in which a plurality of communication modes each having a

30

transmission rate different from each other is intermixed.

Background Art

By setting up a LAN by connecting a plurality of
5 computers to each other, the sharing of information such
as a file and data, and the sharing of peripheral
equipment such as a printer can be achieved, and further
the exchange of information such as the transfer of
electronic mail, data, contents and the like can be
10 preformed.

Conventionally, a wired LAN connection using an
optical fiber, a coaxial cable or a twisted-pair cable
has been generally used. In this case, line construction
work is needed, and it is difficult to set up a network
15 easily. Furthermore, the laying of a cable is
troublesome. In addition, after setting up a LAN,
because the moving range of an apparatus is limited by
the length of a cable, the wired LAN is inconvenient.

Accordingly, a wireless LAN is noticed as a system
20 for releasing a user from LAN wiring of the wired system.
Because almost all of wiring cables can be omitted in a
work space such as an office in case of the wireless LAN,
communication terminals such as personal computers (PC's)
can be relatively easily moved.

25 In recent years, as the wireless LAN system has
become high in speed and low in cost, the demand of the
wireless LAN has been remarkably increased. In
particularly, in the most recent days, for performing
information communication among a plurality of electronic
30 apparatus existing around a person by setting up a small-
scale wireless network among them, the introduction of a

personal area network (PAN) has been examined. For example, different wireless communication systems using frequency bands such as a 2.4 GHz band and a 5 GHz band which are not required to be licensed by the competent
5 authorities to use have been defined.

As normal standards with regard to the wireless network, Institute of Electrical and Electronics Engineers (IEEE) 802.11 (see, for example, Non-Patent Document 1), High Performance Wireless Local Area Network
10 (HIPERLAN)/2 (see, for example, Non-Patent Document 2 or Non-Patent Document 3), IEEE 802.15.3, Bluetooth communication and the like can be cited. The IEEE 802.11 standard includes various wireless communication systems such as an IEEE 802.11a standard and an IEEE 802.11b
15 standard according to the differences of a wireless communication system, a frequency band to be used, and the like.

A method of providing an apparatus to be a control station called as an "access point" or a "coordinator" in
20 an area to form a network under the generalized control by the control station for constituting a local area network by means of a wireless technique is generally used.

A wireless network locating an access point therein
25 widely adopts an access control method based on a band reservation, in which when a certain communication apparatus performs an information transmission, the communication apparatus first reserves a band necessary for the information transmission at an access point for
30 using a transmission path in order not to generate any collisions with the information transmission of another

communication apparatus. That is, the wireless network performs a synchronized wireless communication in which each communication apparatus in the wireless network is synchronized with each other by locating the access point.

5 However, there is a problem in which the usability of a transmission path is reduced to half when an asynchronous communication is performed between communication apparatus on a transmission side and a reception side in a wireless communication system locating an access point therein because the wireless communication through the access point is certainly necessary.

15 On the other hand, as another method for constituting a wireless network, an "ad-hoc communication" in which terminals are directly perform wireless communications with each other asynchronously has been devised. In particular, in a small-scale wireless network composed of a relatively few clients positioned near to each other, the ad-hoc communication, by which arbitrary terminals can directly perform asynchronous wireless communications with each other without using a specific access point, is considered to be suitable.

25 Because there is no central control station in an ad-hoc type wireless communication system, the system is suitable for constituting, for example, a home network composed of household electric apparatus. An ad-hoc network has the following features. That is, even if a terminal is in trouble or the power source thereof is off, a routing can be automatically changed, and

30

consequently the network is difficult to break. Also, data can be transmitted relatively long distance while keeping a high-speed data rate by making a packet hop a plurality of times between mobile stations. Many development examples with regard to the ad-hoc system are known (see, for example, Non-Patent Document 4).

For example, in an IEEE 802.11 series wireless LAN system, an ad-hoc mode in which terminals operate in an autonomous distributed way in peer to peer without locating any control station is prepared.

Hereupon, it is necessary to avoid contention when a plurality of users accesses the same channel. As a typical communication procedure for avoiding the contention, carrier sense multiple access with collision avoidance (CSMA) is known. The CSMA indicates a connection method of performing multiple access on the basis of carrier detection. Because it is difficult to receive a signal which a terminal itself has performed an information transmission thereof in a wireless communication, a terminal starts own information transmission after confirming the nonexistence of information transmissions of the other communication apparatus not by a CSMA/collision detection (CD) method but by a CSMA/collision avoidance (CA) method for avoiding any collisions.

A communication method based on the CSMA/CA is described with reference to Fig. 11. In the example shown in the drawing, it is supposed that there are four communication stations #0 to #3 under a certain communication environment.

Each communication station having transmission data

monitors a medium state for a predetermined inter frame space, or a distributed coordination function (DCF) inter frame space (DIFS), from the last detection of a packet. When any media are clear, namely when there are no transmission signals, the communication station performs random backoff. Furthermore, when there are no transmission signals also in this period, a transmission right is given to the communication station.

In the shown example, after monitoring the medium state for an inter frame space DIFS, the communication station #0, which has the random backoff set to be shorter than that of the other peripheral stations, acquires the transmission right to be able to start a data transmission to the communication station #1.

At the data transmission, the communication station #0, or the transmission source, stores the information for a network allocation vector (NAV), and describes a period of time until the completion of the transaction of a data communication in a duration field of the header of a MAC frame (MAC header).

The communication station #1, or the transmission destination of the data frame, performs a reception operation of the data addressed to the local station for the duration of the Duration described in the MAC header. When the data reception has been completed, the communication station #1 returns an ACK packet to the communication station #0, or the data transmission source.

Moreover, the communication stations #2 and #3, which have received the data frame, and which are not the data transmission destinations, decode the description in

the Duration field of the MAC header, and recognize the state in which the medium is occupied without monitoring the medium until the transaction ends to stop the transmission. The work is called that the peripheral stations "raise a NAV", or the like. The NAV is effective over the duration indicated in the Duration field. For example, the duration until the communication station #1, or the reception destination, will return the ACK packet is specified as the Duration.

10 In such a way, according to the CSMA/CA system, contention is avoided while a single communication station acquires a transmission right, and while peripheral stations stop their data transmission operations during the duration of the data communication operation, and thereby collisions can be avoided.

15 Hereupon, it is known that a concealed terminal problem is generated in a wireless LAN network in an ad-hoc environment. The concealed terminal indicates a communication station which a communication station on one side of a communication party can hear but a communication station on the other side of the communication party cannot hear in case of performing a communication between certain specific communication stations. Because no negotiations can be performed between concealed terminals, there is the possibility that transmission operations collide with each other only by the above-mentioned CSMA/CA system.

20 A CSMA/CA in accordance with an RTS/CTS procedure is known as a methodology for solving the concealed terminal problem. Also in the IEEE 802.11, the methodology is adopted.

In an RTS/CTS system, a data transmission source communication station transmits a transmission request packet Request To Send (RTS), and starts a data transmission in response to the reception of a confirmation note packet Clear To Send (CTS) from a data transmission destination communication station. Then, when a concealed terminal receives at least one of the RTS and the CTS, the concealed terminal sets a transmission stop duration of the local station for the duration in which the data transmission based on the RTS/CTS procedure is expected to be performed, and thereby collisions can be avoided. The concealed terminal for a transmission station receives the CTS to set a transmission stop duration for avoiding the collision with a data packet. The concealed terminal for a reception station receives the RTS to stop the transmission duration for avoiding the collision with the ACK.

Fig. 12 shows an operation example of the RTS/CTS procedure. Incidentally, it is supposed that there are four communication stations #0 to #3 in the communication environment of the wireless communication environment. The communication stations #0 to #3 are supposed to be in the following state. That is, the communication station #2 can communicate with the adjacent communication station #0. The communication station #0 can communicate with the adjacent communication stations #1 and #2. The communication station #1 can communicate with the adjacent communication stations #0 and #3. The communication station #3 can communicate with the adjacent communication station #1. However, the

communication station #2 is a concealed terminal for the communication station #1, and the communication station #3 is a concealed terminal for the communication station #0.

5 Each communication station having transmission data monitors a medium state for a predetermined inter frame space DIFS (DCF Inter Frame Space) until the communication station has detected a packet last. When the medium is clear, namely when there are no
10 transmission signals, during this period of time, the communication station performs random backoff. Moreover, when there are no transmission signals also during this period of time, the communication station is given a transmission right.

15 In the example shown in the drawing, the communication station #0, which has set the random backoff shorter than that of the other peripheral stations after the monitoring of the medium state for the inter frame space DIFS, can acquire the transmission
20 right to start the data transmission to the communication station #1.

 That is, the communication station #0, which transmits data, transmits a transmission request packet (RTS) to the communication station #1. On the other
25 hand, the communication station #1 being the reception destination returns a confirmation note (CTS) to the communication station #0 after a shorter inter frame space Short IFS (SIFS). Then, the communication station #0 responds to the reception of the CTS packet to start
30 the transmission of a data packet after the inter frame space SIFS. Moreover, when the communication station #1

completes the reception of the data packet, the communication station #1 returns an ACK packet with an inter frame space SIFS put between. Because the inter frame space SIFS is shorter than the inter frame space DIFS, the communication station #1 can transmit the CTS packet before the other stations, which acquires the transmission right after waiting for DIFS + random backoff in accordance with a CMA/CA procedure.

At this time, the communication station #2 and the communication station #3, both located at positions where both of them can be concealed terminals from both of the communication station #0 and the communication station #1, performs control to detect the use of a transmission path by the reception of the RTS or the CTS, and not to perform any transmissions until the communication ends.

To put it more specific, the communication station #2 detects the start of the data transmission of the communication station #1 as the transmission source on the basis of an RTS packet, and decodes the Duration field described in the MAC header of the RTS packet, and further recognizes that the transmission path has been already used after that for the duration until the successive transmission of the data packet is completed (the duration until the end of ACK). Thereby, the communication station #2 can raise a NAV.

Moreover, the communication station #3 detects the start of the data transmission of the communication station #1 as the reception destination on the basis of the CTS packet, and decodes the Duration field described in the MAC header of the CTS packet, and further recognizes that the transmission path has been already

used after that during the duration until the transmission of the successive data packet is completed (the duration until the ACK had ended). Thereby, the communication station #3 can raise a NAV.

5 In such a way, when a concealed terminal receives at least one of the RTS and the CTS, the concealed terminal sets the transmission stop duration of the local station for the duration to be expected to perform the data transmission based on the RTS/CTS procedure.
10 Consequently, collisions can be avoided.

 Now, the standardization of the IEEE 802.11g for supporting higher speed communication rate as a higher rank standard of the IEEE 802.11b being a wireless LAN specification using 2.4 GHz band has been advanced. A
15 communication station in accordance with the IEEE 802.11g (hereinafter also referred to "high-grade communication station" simply) can also operate in accordance with the IEEE 802.11b, and can transmit a data packet also at a high-speed rate at which a conventional communication
20 station in accordance with the IEEE 802.11b (hereinafter also referred to as "conventional station" simply) cannot perform any reception.

 Hereupon, there is a problem of the coexistence of different communication systems, or a problem of the
25 coexistence of the IEEE 802.11g and the IEEE 802.11b, both using the same band. That is, because the conventional station cannot receive a data packet to be transmitted at a high-speed rate, the conventional station cannot decode the Duration described in the MAC
30 header, and cannot raise a NAV appropriately. Consequently, the conventional station cannot avoid

collisions.

For example, in the example shown in Fig. 11, the communication station #0 and the communication station #1, both being communication parties, can exchange a data packet at a high-speed rate in conformity with IEEE 802.11g. On the other hand, when the communication station #2 and the communication station #3 around the communication station #0 and the communication station #1 are conventional stations which do not conform to the IEEE 802.11g, the communication stations #2 and #3 cannot decode the Duration described in the MAC header as a result of being unable to receive the data packet. Consequently, there is the possibility that the communication stations #2 and #3 start their communication operation even in the duration of the Duration to generate a collision (see Fig. 13).

The present inventors consider that the problem of the coexistence of the IEEE 802.11g and the IEEE 802.11b is preferably solved by the setting of the IEEE 802.11g, being a higher rank standard, to assure ad-hoc compatibility.

For example, a method of performing the exchange of an RTS/CTS packet at a transmission rate at which a conventional station can receive the RTS/CTS packet before the transmission of a data packet in IEEE 802.11g can be considered (see Fig. 14). In this case, peripheral conventional stations decodes the Duration field described in the MAC header of the RTS/CTS packet, and recognize that the transmission path has already used for the duration until the completion of the transmission of the successive data packet after that (the duration

until ACK ends). Thereby, the peripheral conventional stations can raise an NAV only for suitable duration. That is, the conventional stations cannot hear a data packet to be transmitted at a high-speed rate, but that
5 turns to be no problem for avoiding a collision.

A procedure for securing a band in accordance with the above-mentioned procedure before the transmission of a data packet is generally called a virtual carrier sense.

10 However, in such a band securing procedure, the transmission of a data packet cannot be performed without performing the RTS/CTS procedure certainly not only in the case where the concealed terminal problem is generated, but also in the case where the concealed
15 terminal problem does not exist. That is, the faster the transmission rate becomes, the larger the problem of an RTS/CTS overhead becomes. Also, the communication efficiency decreases by the degree of the problem.

20 Non-Patent Document 1: International Standard ISO/IEC 8802-11: 1999(E) ANSI/IEEE Std. 802.11, 1999 Edition, Part 11: Wireless LAN Medium Access Control (MAC) and PHYsical Layer (PHY) Specifications.

Non-Patent Document 2: ETSI Standard ETSI TS 101
25 761-1 V1. 3.1 Broadband Wireless Access Networks (BRAN); HIPERLAN Type 2; Data Link Control (DLC) Layer; Part1: Basic Data Transport Functions.

Non-Patent Document 3: ETSI TS 101 761-2 V1. 3.1
30 Broadband Wireless Access Networks (BRAN); HIPERLAN Type 2; Data Link Control (DLC) Layer; Part 2: Wireless Link Control (RLC) sublayer.

Non-Patent Document 4: C. K. Tho, "Ad-Hoc Mobile Wireless Network" (Prentice Hall PTR Corp.).

Disclosure of Invention

5 It is an object of the present invention to provide a superior wireless communication system, a wireless communication apparatus, a wireless communication method, and a computer program in which each communication station can suitably perform random access by the CSMA
10 system on the basis of carrier detection.

 It is another object of the present invention to provide a superior wireless communication system, a wireless communication apparatus, a wireless communication method, and a computer program which can
15 realize random access in a communication environment in which a plurality of communication modes each having a different transmission rate to each other intermixes.

 It is a further object of the present invention to provide a superior wireless communication system, a
20 wireless communication apparatus, a wireless communication method, and a computer program which can realize random access with a smaller overhead in a communication environment in which a plurality of communication modes each having a different transmission
25 rates to each other intermixes.

 The present invention was made in consideration of the above-mentioned problems. A first aspect of the present invention is a wireless communication system in which a first communication station operating according
30 to a first communication method and a second communication station capable of operating according to

both of the first communication method and a second communication method coexist, wherein the second communication station transmits a packet composed of a first decoding portion capable of being received according to the first communication method, and a second decoding portion capable of being received according to the second communication method.

In this case, the "system" hereupon indicates a matter made of a plurality of logically aggregate apparatus (or logically aggregate functional modules realizing specific functions), and it does not matter whether each of the apparatus or the functional modules is in a single housing or not.

Moreover, the first communication method hereupon corresponds to, for example, the IEEE 802.11b being a wireless LAN specification using a 2.4 GHz band, and the second communication method corresponds to the IEEE 802.11g supporting a high-speed communication rate as a higher rank standard of the IEEE 802.11b.

Under such communication environment, there is a problem of the coexistence of the IEEE 802.11g and the IEEE 802.11b, both using the same frequency band.

For example, when a transmission and a reception of a packet is performed by random access, for example, the local station transmits a data packet as a data transmission station, and hopes that peripheral stations stop their communication operations for expected duration until an ACK is returned from a reception station. Moreover, when the RTS/CTS procedure is adopted, for example, the local station transmits an RTS or a CTS packet, and hopes that the peripheral stations stop their

communication operations for the expected duration until the ACK is returned. However, when the second communication station operating in accordance with the higher rank standard performs a packet transmission according to the second communication method, a conventional station cannot receive the data packet transmitted at a high-speed rate, and cannot decode a duration described in a MAC header. Then, the conventional station cannot raise a NAV suitably, and cannot avoid a collision.

In the wireless communication system according to the present invention, a packet is composed of a first decoding portion capable of being received according to a first communication method, and a second decoding portion capable of being received according to a second communication method. The first decoding portion includes information related to a packet length and a transmission rate of the packet. Further, the first communication station that receives the packet calculates $(\text{packet length})/(\text{transmission rate})$ on the basis of the packet length and the transmission rate of the packet, both capable of being obtained by decoding the first decoding portion, in order to obtain a residual reception period of time of the packet.

Then, when the second communication station performs a communication procedure according to the second communication method, the second communication station describes spoofed information of a packet length and a transmission rate in the first decoding portion like the indication of the duration for which communication operations of the other stations are stopped by (packet

length)/(transmission rate) for the sake of the communication procedure. In such a case, the first communication station cannot receive the second decoding portion of the packet, but can avoid a collision by calculating the (packet length)/(transmission rate) on the basis of the description in the first decoding portion to raise the NAV for desired duration, and by stopping any data transmissions.

That is, in the wireless communication system according to the present invention, the second communication station performing a packet transmission spoofs about the information of the packet length and the transmission rate to be described in the first decoding portion in order that the first communication station receiving the packet may stop its communication operation for the duration until a communication transaction to be performed according to the second communication method ends. Thereby, the second communication station performing the second communication method realizes the so-called upper compatibility to the first communication station.

The duration until the communication transaction ends hereupon, specifically indicates the duration until an ACK transmission ends in a communication procedure performed according to the second communication method. Moreover, when a packet transmission is performed in accordance with a communication procedure to perform multiple connections with a plurality of communication stations in the second decoding portion, the duration hereupon indicates the duration until all of the ACK transmissions performed in a time division multiplex from

each remote station end. Moreover, the transmission of the ACK packet hereupon is not limited to the case of single ACK packet, but includes, for example, the case where the ACK packet is multiplexed with other kinds of packets such as an RTS packet, a CTS packet, and data packet to be transmitted.

For the second communication station described above realizes the mechanism of the ad-hoc compatibility, it is necessary for each second communication station to recognize that the information of the packet length and the transmission rate described in the first decoding portion is spoofed. Moreover, it is necessary that each second communication station mutually recognizes the spoofing of the information while the first communication station cannot know the spoofing of the information to operate in accordance with the description in the first decoding portion.

Accordingly, in the wireless communication system according to the present invention, the second communication station performing a packet transmission describes whether the spoofed information of a packet length and a transmission rate is described in the first decoding portion or not in a packet in a format which the second communication station capable of operating according to the second communication method can decode the spoofed information but the first communication station operating according to the first communication method cannot decode the spoofed information.

For example, the second communication station performing a packet transmission indicates whether the spoofed information of the packet length and the

transmission rate is described or not by means of a spoofed flag in the first decoding portion.

In this case, when the second communication station being a data reception side detects that the information of the packet length and the transmission rate in the first decoding portion of a packet received from another station is spoofed, the second communication station switches its reception method to the second communication method, and can perform the reception operation of the residual portion of the packet.

Moreover, the second communication station performing a packet transmission may be provided with a known second communication method decoding portion, in which all of the second communication stations can decode data, in a packet, and may describe whether spoofed information of a packet length and a transmission rate is described or not in the second communication method decoding portion for notifying the other second communication stations of the spoofing. For example, when a plurality of communication modes each having a transmission rate different from each other is defined as the second communication method, an actually used communication mode may be described in the second communication method decoding portion.

It is preferable that a second communication station performing a packet transmission transmits the second communication method decoding portion in a communication method in which all of the second communication stations can decode the data in the second communication method decoding portion but the first communication stations cannot decode the data. For example, the second

communication station performing the packet transmission transmits the second communication method decoding portion at a low transmission rate of about 6 Mbps in order that all of the second communication stations can receive, but the second communication station performing the packet transmission performs the modulation processing of the second communication method decoding portion in accordance with a modulation system which each of the second communication stations knows but the first communication stations do not know. Thereby, only the second communication stations can demodulate the second communication method decoding portion to recognize that the first decoding portion is spoofed.

In such a case, a second communication station receiving the packet tries to decode the second communication method decoding portion by means of both of the first communication method and the communication method by which the first communication station cannot decode the second communication method decoding portion, and the second communication station can recognize that the first decoding portion is spoofed by the fact that the second communication method decoding portion can be decoded according to the latter method. Then, the second communication station can perform the reception processing of the second decoding portion in accordance with the communication mode obtained from the second communication method decoding portion.

For example, the second communication station locates the second communication method decoding portion before the second decoding portion in a packet. Then, when the second communication station describes the

spoofed information of a packet length and a transmission rate for the first communication stations in the first decoding portion, the second communication station describes the information related to an actual packet length and a transmission rate in the second decoding portion in the second communication method decoding portion. In such a case, a second communication station receiving the packet can perform the reception operation of the second decoding portion after the second communication method decoding portion of the received packet on the basis of the information related to the packet length and the transmission rate described in the second communication method decoding portion.

A second communication station performing a packet transmission can make data to be able to be decoded by all of the second communication stations and to be unable to be decoded by the first communication stations by modulating the second communication method decoding portion in accordance with a modulation system which only each of the second communication station knows. For example, when the second communication station performs a phase modulation such as BPSK to the second communication method decoding portion, the second communication station may give a phase difference θ , which is jointly owned by the second communication station, to the location of a signal point $(-1, 1)$, or may translation the signal point by the known quantity Δd . On the other hand, a second communication station receiving the packet performs phase demodulation in consideration of the phase shifts of the location of the signal point such as the phase difference $-\theta$, the movement quantity $-\Delta d$ and the like. Then, it can

be known that the first decoding portion is spoofed by the fact that the second communication method decoding portion can be decoded.

Incidentally, in the case where a second
5 communication station capable of operating according to the second communication method is located at a position far from a transmission source, a situation in which the second communication station can receive a second communication method decoding portion, which is
10 transmitted at a low transmission rate, but cannot receive the second decoding portion, which is transmitted at a high-speed transmission rate, owing to an S/N, can be also supposed. In such a case, a second communication station receiving a packet tries to perform the reception
15 operation of a second decoding portion on the basis of the information related to a packet length and a transmission rate described in the second communication method decoding portion of the received packet. When the second communication station cannot decode the second
20 decoding portion, the second communication station may obtain a difference between a period of time (i.e. (packet length)/(transmission rate)) obtained from the spoofed packet length and the transmission rate described in the first decoding portion and a period of time (i.e.
25 (packet length)/(transmission rate)) obtained from the packet and the transmission rate described in the second communication method decoding portion, and may restrain the transmission of a packet for a predetermined period of time.

30 The wireless communication system according to the present invention supposes, for example, a communication

environment in which a conventional station operating in accordance with the IEEE 802.11b and a high-grade communication station operating in conformity with the IEEE 802.11g corresponding to a high-speed edition standard using the same band intermixedly operate.

In the wireless communication system according to the present invention, a packet to be transmitted is composed of a known fixed rate portion (hereinafter also referred to as "general decoding portion") which all of the communication stations can decode, and an arbitrary rate portion (hereinafter also referred to as "high-grade decoding portion") which possibly only a part of the communication station being at a high-grade can decode.

The general decoding portion of a packet generally describes a residual length of the packet and a rate at which residual packets are transmitted therein. Consequently, a communication station receiving the packet tries to receive the residual part of the packet by performing the reception operation of the packet at a specified rate for the duration of (packet length)/(rate).

In the present invention, a high-grade communication station performs a packet transmission at a transmission rate at which a conventional station cannot receive the packet. Also, when a conventional station is not desired to start a transmission for fixed duration, the information of a packet length and a rate in the general decoding portion is spoofed in order that the value of (packet length)/(rate) may be the duration for which the communication is desired to be stopped. For example, the value of (packet length)/(rate) should originally

correspond to the reception duration of the residual portion of the packet. However, for example, the information is spoofed in order to be the duration for which a NAV such as the end of ACK should be raised.

5 Moreover, in this case, the high-grade communication station to be a communication party is needed to detect that these values described in the general decoding portion are spoofed for performing a correct reception operation without performing any malfunctions on the
10 basis of the spoofed rate and the length. For this sake, a flag indicating the existence of spoofing is provided in the general decoding portion of a packet. Alternatively, a second communication method decoding portion, which all second communication stations can
15 decode, is provided, and the fact that the general decoding portion is spoofed is described in the second communication method decoding portion. Then, after the general decoding portion has been transmitted, the high-grade communication station shifts to an arbitrary high
20 grade rate mode, and transmits an actual data composed of a high-grade decoding portion.

When the conventional station receives a general decoding portion including the spoofed information of a packet length and a rate, the conventional station
25 believes the packet length and the rate to receive the residual packet at a specified rate for a period of $(\text{packet length})/(\text{rate})$. Because the rate and the packet length are different from ones at which the packet is actually transmitted, the conventional station cannot
30 decode the packet correctly, and the packet is destroyed.

On the other hand, a high-grade communication

station detects that the information of a packet length and a rate is spoofed by means of the flag in the general decoding portion. Alternatively, the high-grade communication station detects the spoofing owing to the capability of decoding the second communication method decoding portion. Then, when the general decoding portion is spoofed, the high-grade communication station shifts to the corresponding high grade rate mode, and receives the residual packet, i.e. a high-grade decoding portion. Thus, the high-grade communication station can decode actual data.

As described above, in the case where a packet length and a rate are used for setting a period of time during which all transmission starts are stopped, there are plurality of combinations of spoofed packet lengths and spoofed rates for showing the same period of time to the conventional station. On the other hand, there is a plurality of transmission modes as a high-speed communication rate sometimes. Accordingly, when a plurality of modes each including high-speed communication rate, a mode by which the residual packet is transmitted may be presumed by the setting of a rate.

Moreover, a second aspect of the present invention is a computer program described in a form capable of being read by a computer to execute on a computer system processing for a wireless communication operation in a wireless communication environment in which a first communication method and a second communication method coexist, the program including the steps of: generating a transmission packet composed of a first decoding portion and a second decoding portion, transmitting a first

decoding portion of the transmission packet according to the first communication method, and transmitting a second decoding portion of the transmission packet according to the second communication method, receiving and analyzing a first decoding portion of a reception packet from another station, and receiving and analyzing a second decoding portion of the reception packet according to the second communication method.

The computer program according to the second aspect of the present invention defines a computer program described in the form capable of being read by a computer for realizing predetermined processing on a computer system. In other words, by installing the computer program according to the second aspect of the present invention into a computer system, a cooperative operation is exhibited on the computer system, and the computer system operates as a wireless communication apparatus. By building a wireless network by activating a plurality of such wireless communication apparatus, operations and advantages similar to those of the wireless communication system according to the first aspect of the present invention can be obtained.

According to the present invention, it is possible to provide a superior wireless communication system, a wireless communication apparatus, a wireless communication method and a computer program in which each communication station can suitably perform random access on the basis of a carrier detection according to a CSMA system.

Moreover, according to the present invention, it is possible to provide a superior wireless communication

system, a wireless communication apparatus, a wireless communication method and a computer program in which random access can be realized in a communication environment in which a plurality of communication modes each having a transmission rate different from each other intermixes.

Moreover, according to the present invention, it is possible to provide a superior wireless communication system, a wireless communication apparatus, a wireless communication method and a computer program in which random access can be realized with a smaller overhead in a communication environment in which a plurality of communication mode, each having a transmission rate different from each other, intermixes.

According to the present invention, the coexistence of the IEEE 802.11g and the IEEE 802.11a/b, both using the same band, can be realized without passing an RTS/CTS procedure. Consequently, an overhead can be remarkably reduced.

Moreover, according to the present invention, the duration for an NAV can be flexibly set. Consequently, the throughput of a system can be improved.

Further objects, features and advantages of the present invention will be apparent by more detailed descriptions based on the embodiments of the present invention and the attached drawings, which will be described later.

Brief Description of Drawings

Fig. 1 is a view schematically showing a functional configuration of a wireless communication apparatus

operating as a communication station in a wireless network according to one embodiment of the present invention;

Fig. 2 is a view for illustrating a mechanism of a priority transmission based on difference of inter frame spaces;

Fig. 3 is a view schematically showing one example of a frame configuration of a packet in the wireless network according to the present invention;

Fig. 4 is view schematically showing a variation of a packet structure in the wireless network according to the present invention;

Fig. 5 is a view showing a description example of Rate field in the IEEE 802.11a;

Fig. 6 is a flowchart showing a reception processing procedure in the case where a wireless communication apparatus 100 operates as a conventional station;

Fig. 7 is a flowchart showing a reception processing procedure in the case where the wireless communication apparatus 100 operates as a high-grade communication station;

Fig. 8 is a view showing one of communication operation examples based on CSMA/CA according to the present invention;

Fig. 9 is a view showing one of communication operation examples based on RTS/CTS according to the present invention;

Fig. 10 is a view showing one of communication operation examples based on RTS/CTS using Shot NAV according to the present invention;

Fig. 11 is a view showing a communication operation

example base on CSMA/CA according to a conventional technology;

Fig. 12 is a view showing a communication operation example based on RTS/CTS according to a conventional
5 technology;

Fig. 13 is a view showing a communication operation example based on CSMA/CA under a communication environment in which conventional stations and high-grade communication stations intermix according to a
10 conventional technology;

Fig. 14 is a view showing a communication operation example based on RTS/CTS in conformity with the IEEE 802.11g according to a conventional technology;

Fig. 15 is a view showing one example of the
15 internal configuration of a wireless reception unit 110 of a high-grade communication station capable of decoding a SIGNAL-2 portion;

Fig. 16 is a view showing one example of the frame configuration of a packet transmitted according to the
20 second communication method; and

Fig. 17 is a view showing communication operation sequencing by which a plurality of reception stations replies by a time division response packet to a transmission packet from a transmission station.
25

Best Mode for Carrying Out the Invention

The embodiments of the present invention are described in detail hereinafter with reference to the attached drawings.

30 Channels of communication supposed in the present invention are wireless channels, and a network is built

among a plurality of communication stations. Communication supposed in the present invention is a store and forward type traffic, and information is transferred per packet. Moreover, although each communication station is supposed to have a single channel in the following description, it is also possible to expand the description to the case where a transmission medium composed of a plurality of frequency channels, i.e. multi channels, is used.

10 In a wireless network according to the present invention, each communication station directly (randomly) transmits information in accordance with an access procedure based on a carrier sense multiple access (CSMA) (carrier detection multiple connection), and can build an autonomous distributed type wireless network. Moreover, in the wireless network according to the present invention, transmission control using channel resources effectively is performed by means of transmission (MAC) frame in a gentle time division multiplexing access structure. In this case, each communication station can perform an access system based on a time synchronization such as reserving a frequency band and setting a priority use duration.

25 One embodiment of the present invention supposes, for example, a communication environment in which both high-grade communication stations in conformity with the IEEE 802.11g corresponding to a high-speed edition standard using the same band and a conventional station in conformity with the conventional IEEE 802.11b intermixedly operate. That is, there are two kinds of communication terminals, that is; conventional stations

which can transmit and receive only the packets modulated according to some limited modulation systems; and high-grade communication stations which can receive packets according to a high-grade system in addition to the modulation system by which the conventional station can receive packets.

The communication system in which the IEEE 802.11g and the IEEE 802.11b, both using the same band, intermix has a problem of coexistence. The reason is that, because the conventional station cannot receive a data packet transmitted at a high-speed rate, the conventional station cannot decode the Duration described in a MAC header to raise an NAV suitably, and consequently cannot avoid a collision. The present invention solves the coexistence problem by securing that the higher rank standard IEEE 802.11g assures the conventional standard IEEE 802.11b of the so-called upper compatibility. The solving method will be described later.

Fig. 1 schematically shows a functional configuration of a wireless communication apparatus operating as a communication station in a wireless network according to one embodiment of the present invention. A wireless communication apparatus 100 shown here can form a network while avoiding a collision in the same wireless system by performing a channel access effectively. The wireless communication apparatus 100 is either of a conventional station in conformity with the IEEE 802.11a/b as a first communication method and a high-grade communication station in conformity with the IEEE 802.11g as a second communication method.

As shown in Fig. 1, the wireless communication

apparatus 100 is composed of an interface 101, a data buffer 102, a central control unit 103, a packet generation unit 104, a wireless transmission unit 106, a timing control unit 107, an antenna 109, a wireless
5 reception unit 110, a packet analysis unit 112, and an information storage unit 113.

The interface 101 performs exchanges of various kinds of information between the wireless communication apparatus 100 and an external apparatus (such as a
10 personal computer, though not shown) connected to the wireless communication apparatus 100.

The data buffer 102 is used for temporarily storing the data transmitted from the external apparatus connected to the wireless communication apparatus 100
15 through the interface 101, and the data received through a wireless transmission path before transmitting the data through the interface 101.

The central control unit 103 unitarily performs the administration of series of information transmission and
20 reception processing in the wireless communication apparatus 100 and the access control of transmission paths. Basically, the central control unit 103 sets a timer of backoff to operate over a random period of time on the basis of CSMA while monitoring the states of the
25 transmission paths, and performs access contention of acquiring a transmission right in the case where no transmission signals exist during this period of time.

The present embodiment adopts a mechanism of a priority transmission in the access contention to realize
30 flexible QoS (see Fig. 2). For example, the wireless communication apparatus 100 takes a normal operation mode

after a packet transmission of another station or at the time of low traffic priority, and sets an inter frame space IFS to a longer DIFS, and further sets the random backoff. On the other hand, in case of performing the transmission of CTS successively to RTS from another station, in case of performing the transmission of a data packet successively to CTS, and in case of the transmission of ACK, the wireless communication apparatus 100 sets the inter frame space IFS to a shorter SIFS, which enables a transmission prior to the other stations performing normal transmission operations.

The packet generation unit 104 generates a packet signal to be transmitted from the local station to a peripheral station. The packet hereupon includes a transmission request packet RTS from a communication station being a reception destination, a confirmation response packet CTS to the transmission request packet RTS, an ACK packet and the like as well as a data packet. For example, a data packet is generated by taking out of the transmission data stored in the data buffer 102 for a predetermined length to be set as a payload.

In a MAC layer of a communication protocol, a MAC frame is configured by adding a MAC header to a payload, and furthermore a PHY header is added at a PHY layer to be a final transmission packet structure. In the present embodiment, the PHY header constitutes a first decoding portion, and the MAC frame portion constitutes a second decoding portion. The configuration of a packet signal will be described later.

The wireless transmission unit 106 and the wireless reception unit 110 correspond to an RF layer and the PHY

layer in the communication protocol.

The wireless transmission unit 106 performs the wireless transmission processing of a packet signal according to a predetermined modulation system and a transmission rate. To put it more specific, the wireless transmission unit 106 includes a modulator for modulating a transmission signal according to the predetermined modulation system, a D/A converter for converting a digital transmission signal into an analog signal, an up-converter for performing the frequency conversion of an analog transmission signal to up-convert the analog transmission signal, a power amplifier (PA) for amplifying the electric power of the up-converted transmission signal (all of them are not shown). The wireless transmission unit 106 performs the wireless transmission processing at a predetermined transmission rate.

Moreover, the wireless reception unit 110 performs the wireless reception processing of the packet signal from another station. To put it more specific, the wireless reception unit 110 is composed of a low noise amplifier (LNA) for amplifying the voltage of a wireless signal receiving from another station through the antenna 109, a down-converter for down-converting the voltage-amplified reception signal by frequency conversion, an automatic gain controller (AGC), an A/D converter for performing the digital conversion of an analog reception signal, a demodulator for performing a synchronous processing for acquiring a synchronization, a channel estimation, a demodulation processing by means of a demodulation system such as OFDM, and the like (all of

them are not shown).

In the case where the wireless communication apparatus 100 conforms to the IEEE 802.11a/b as the first communication method, the wireless transmission unit 106 and the wireless reception unit 110 respectively perform a transmission and a reception of a packet according to a modulation system and a transmission rate in conformity with a wireless LAN standard. Moreover, in the case where the wireless communication apparatus 100 conforms to the IEEE 802.11g as the second communication method, it is possible for the wireless communication apparatus 100 to perform a transmission and reception of a packet according to a modulation system and a transmission rate in conformity with the IEEE 802.11a/b. In addition, the wireless communication apparatus 100 can perform a transmission and a reception of a packet at a transmission rate inherent to the IEEE 802.11g (i.e. a transmission and a reception unable to be received by the IEEE 802.11a/b). In the latter case, the first decoding portion of a packet composed of the PHY header is transmitted and received at a transmission rate capable of being received by the IEEE 802.11a/b, but the second decoding portion composed of the MAC frame is transmitted and received at a transmission rate in conformity with the IEEE 802.11g.

The antenna 109 performs the wireless transmission of a signal to another wireless communication apparatus on a predetermined frequency channel, or collects a signal transmitted from another wireless communication apparatus. The present embodiment is provided with a single antenna, and it is supposed that a transmission

and a reception cannot simultaneously performed in parallel.

The timing control unit 107 controls a timing for transmitting and receiving a wireless signal. For example, the timing control unit 107 controls its own packet transmission timing, the transmission timing of each packet (such as RTS, CTS, data, and ACK) in conformity with the RTS/CTS system (setting of an inter frame space IFS and the backoff), the setting of the NAV at the time of reception of a packet addressed to another station, and the like.

The packet analysis unit 112 analyzes the packet signal which can be received from another station. In the present embodiment, the packet is composed of a first decoding portion and a second decoding portion. The details of a packet decoding method will be described later.

The information storage unit 113 stores an execution procedure instruction of a series of access control operations to be executed by the central control unit 103, and information obtained from an analysis result of a reception packet.

As described above, in a wireless network of the present embodiment, there are two kinds of communication stations of conventional stations capable of the transmission and the reception of a packet modulated according to some limited modulation systems, and high-grade communication stations capable of the reception in conformity with a high-grade system in addition to the modulation systems in which the conventional stations can perform receptions. There is a coexistence problem in a

communication system in which the IEEE 802.11g and the IEEE 802.11b using the same band intermix. The present embodiment solves this problem by making the high-grade communication stations provide the so-called ad-hoc compatibility to the conventional stations. The details of the solution will be described.

Fig. 3 schematically shows the configuration of a packet which the wireless communication apparatus 100 operating as a communication station in the wireless network of the present embodiment transmits and receives.

In a MAC layer of the communication protocol, a MAC frame is constituted by adding a MAC header to a payload (corresponding to an IP packet). Moreover, in a PHY layer, a PHY header is added to the MAC frame to be a final transmission packet structure. The PHY header constitutes a first decoding portion, and the MAC frame portion constitutes a second decoding portion. As shown in Fig. 3, a packet is composed of a physical layer convergence protocol (PLCP) preamble portion and a SIGNAL portion as the PHY header, and the MAC frame. The MAC frame is composed of the MAC header and a data portion.

The PHY header corresponds to the first decoding portion, and the MAC frame corresponds to the second decoding portion.

In the case where the transmission station of a packet is a conventional station in conformity with the IEEE 802.11a/b, both of the PHY header and the MAC frame are transmitted according to the first communication method.

Moreover, in the case where the transmission station of a packet is a high-grade communication station in

conformity with the IEEE 802.11g, the communication station transmits the whole packet according to the first communication method when the communication station transmits the packet to a conventional station. On the other hand, when the high-grade communication station transmits a packet to a high-grade communication station, the transmitting communication station transmits only the first decoding portion of the packet according to the first communication method, by which all communication stations can receive the first decoding portion, and can transmit the second decoding portion of the packet including the data portion according to the second communication method having a higher transmission rate.

On the transmission side of the shown packet, first, the PLCP preamble portion is transmitted as the head of the packet, and next, the SIGNAL portion and the MAC frame are transmitted.

The PLCP preamble portion includes elements such as a signal detect (Signal Detect) and a channel estimation (Channel Estimation). Consequently, a peripheral station knows the existence of a signal from a communication station by receiving the PLCP preamble portion, and performs the estimation of a transmission channel and the like.

The communication station knowing the transmission of the signal by the detection of the PLCP preamble portion starts the reception of the subsequently arriving SIGNAL portion. Because the SIGNAL portion is transmitted according to the first communication method, which all communication station know, both of the conventional stations and the high-grade communication

stations can receive the SIGNAL portion.

The SIGNAL portion includes a transmission rate (Rate) of the subsequent MAC frame, the length (Length) of a residual data of the packet such as the MAC frame, parity (Parity), a reserved area (Reserve) and the like.

The MAC frame is modulated according to the transmission rate specified by the transmission rate (Rate) of the SIGNAL portion. The MAC frame is composed of the MAC header and the data portion corresponding to the payload. The MAC header describes an address (RX Address) of the reception station of the packet, Duration specifying the duration in which the stations other than the reception station severally should raise the NAV.

A communication station which can normally receive and decode the MAC header portion compares the address of the local station with the reception address. When they coincide with each other, the communication station receives the residual portion of the packet at a specified rate for the duration of (packet length)/(transmission rate) in accordance with the transmission rate (Rate) and the packet length (Length) information, both described in the SIGNAL portion. Moreover, when its own address and the received address do not coincide with each other, the communication station raises the NAV for the Duration described in the MAC header, and restrains any transmissions from the local station. The procedure for securing a band in accordance with the procedure mentioned above is generally called as virtual carrier sense.

Now, when a transmission station of a packet being a high-grade communication station according to the IEEE

802.11b performs the transmission of the packet to a high-grade communication station, the transmission station transmits only the first decoding portion according to the first communication method, which all communication stations can receive, but transmits the second decoding portion including the data portion according to the second communication method having the higher transmission rate. Consequently, because the conventional stations cannot receive the second decoding portion, the conventional stations cannot decode the Duration described in the MAC header. Consequently, there is a problem in which the conventional stations cannot know the duration for which the conventional stations should severally raise the NAV.

Conventionally, the description of the Duration in the MAC header has been used for band securing. However, for realizing the coexistence of the IEEE 802.11g and the IEEE 802.11a/b, a mechanism is needed for the conventional stations to recognize the duration for which the conventional stations should severally raise the NAV on the basis of other information without using the description of the Duration.

Accordingly, the present embodiment prepares a mechanism in which, even if a packet is transmitted according to the IEEE 802.11g as the second communication method, the first decoding portion, which all communication stations can certainly receive, is provided, and the duration corresponding to the NAV is specified by means of the first decoding portion.

As shown in Fig. 3, the first decoding portion is composed of the PHY header of a packet. Then, the period

of time corresponding to the Duration is described in a pseudo-way in the SIGNAL portion, which all communication stations can receive, by using the information of the transmission rate (Rate) and the packet length (Length).

5 That is, the information of the transmission rate (Rate) and the packet length (Length) is spoofed so that the value of (packet length)/(rate) may be equal to the duration for which any communications are desired to be stopped.

10 As a result, the conventional stations severally set the packet length and the transmission rate, which are different from the fact, and perform the reception for a period of time corresponding to the Duration. The actual packet is not transmitted over the period of (packet
15 length)/(rate), but the conventional stations do not start their transmissions for the duration corresponding to Duration. As a result, the conventional stations restrain their transmissions and continue their receiving for the duration for which communications are desired to
20 be stopped.

Incidentally, in this case, after the conventional stations have performed the receptions for the spoofed period of (packet length)/(rate), CRC errors are certainly generated. The IEEE 802.11 has a rule in
25 which, when a CRC error is generated in the data portion, any receptions are restrained for a period of time EIFS longer than a normal inter frame space DIFS. Accordingly, it is desirable to perform the spoofing so that a period of time obtained by subtracting "EIFS -
30 DIFS" from the duration for which the receptions are truly desired to be continued as the period of (packet

length)/(rate) for avoiding the conventional station being always unfairly treated.

As described above, the high-grade communication stations use the information of the transmission rate
5 (Rate) and the packet length (Length) so as to describe the period of time corresponding to Duration in the first decoding portion in a pseudo-way, and thereby the high-grade communication stations supply the so-called ad-hoc compatibility to the conventional stations. In this
10 case, for a communication procedure according to the high-grade communication method in conformity with the IEEE 802.11g is being performed, the conventional stations avoid any collisions, and thereby a normal network operation can be realized.

15 Moreover, in the case where the high-grade communication stations use a high-speed transmission rate which the first communication method cannot deal with, a value which the first communication method can deal with should be set in the transmission rate (Rate) field of
20 the SIGNAL portion as the spoofing in order that the conventional stations can correctly decode the first decoding portion. In this case, the packet length (Length) should be also spoofed in accordance with the spoofed transmission rate (Rate) value.

25 As described above, the spoofing is performed in the SIGNAL portion in order that the value of (packet length)/(rate) may be equal to the duration for which the conventional stations are desired to stop communications. Hereupon the duration for which the conventional stations
30 are desired to stop communications, in short, indicates the duration until a communication transaction performed

according to the second communication method ends. To
put it more specific, the duration indicates the duration
until an ACK transmission in a communication procedure
performed according to the second communication method
5 ends. Moreover, when packet transmissions are performed
in a communication procedure for performing multiple
connections with a plurality of communication stations in
a MAC frame according to the second communication method,
the above-mentioned duration corresponds to the duration
10 until all of the ACK transmissions performed from each of
the remote stations in time division multiplex end.
Incidentally, Japanese Patent Application No. 2003-297919
which has been assigned to the present applicant,
discloses a communication system in which a transmission
15 station transmits a data frame addressed to a plurality
of reception stations by means of space division multiple
access (SDMA) and each reception station replies ACK in
time division multiplex. Moreover, the transmission of
the ACK packet hereupon is not limited to the
20 transmission of the ACK packet alone, but includes the
case where the ACK packet is multiplexed by the other
kinds of packets such as an RTS packet, a CTS packet and
a Data packet to be transmitted.

Hereupon, it is necessary for a high-grade
25 communication station being a communication party to
detect that the values of spoofed Rate and Length
described in the first decoding portion are spoofed for
performing a correct reception operation without
performing any malfunctions based on the spoofed Rate and
30 Length. That is, for realizing the mechanism of the ad-
hoc compatibility in a high-grade communication station,

it is needed for each high-grade communication station to recognize that the information of a packet length and a transmission rate described in the first decoding portion is spoofed. Moreover, for preventing the conventional stations from knowing that the information is spoofed, only the high-grade communication stations mutually recognize the fact, and the first communication stations should operate in accordance with the description in the first decoding portion.

10 In the embodiment shown in Fig. 3, for example, a flag of one bit indicating the existence of the spoofing is prepared in the reserved area (Reserve) of the SIGNAL portion. Then, when a high-grade communication station detect that the information of the packet length and the rate is spoofed by means of the flag in the first decoding portion, the high-grade communication station shifts to the corresponding high grade rate mode, and can decode actual data by receiving the residual packet, i.e. a high-grade decoding portion. In this case, the high-grade communication station destroys the information of the packet length and the rate read from the SIGNAL portion of the received packet.

25 In the case where only a single communication method (communication mode) is defined in the second communication method for performing the packet transmission and the reception at a high-speed transmission rate, the shift of the communication method can be specified only by means of the spoofed flag of one bit as described above with Fig. 3 being referred to. On the contrary, in the case where the second communication method includes a plurality of transmission modes, it

becomes impossible to specify a transmission mode only by means of the spoofed flag of one bit.

The simplest way of specifying one of a plurality of transmission modes as described above is to add a field for specifying a transmission mode in a packet. Fig. 4 shows a variation of the packet structure shown in Fig. 3. In the shown example, a SIGNAL-2 portion (high throughput (HT) PHY portion) is furthermore added after the SIGNAL portion in a packet transmitted according to the second communication method.

In the shown example, the SIGNAL-2 portion includes a field describing a true transmission rate (True Rate) and a true packet length (True Length), and a field describing a mode parameter value (Mode Parameter). Because the SIGNAL-2 portion is transmitted at a fixed transmission rate at which all high-grade communication stations can perform a reception, the high-grade communication station which has received the packet performs an reception operation in accordance with the true transmission rate (True Rate) and the true packet length (True Length). Moreover, conventional stations cannot decode the SIGNAL-2 portion, and set their reception duration on the basis of the rate and the length described in the SIGNAL portion.

Now, it is needed for each of the high-grade communication stations to recognize the spoofing in the way that the conventional stations cannot know the spoofing of the transmission rate and the packet length in the SIGNAL portion, and the conventional stations should operate in conformity with the description in the SIGNAL portion. For the sake of this, a packet is

transmitted according to the communication method in which all high-grade communication stations can decode the SIGNAL-2 portion (HT-SIGNAL portion) as the second communication method decoding portion and the
5 conventional stations cannot decode the SIGNAL-2 portion.

For example, the SIGNAL-2 portion is transmitted at a low transmission rate of about 6 Mbps for all high-grade communication stations can receive the SIGNAL-2 portion, and a modulation processing of the SIGNAL-2
10 portion is performed according to a modulation system which each of the high-grade communication stations know but the first communication stations do not know. Thereby, only the high-grade communication stations can demodulate the SIGNAL portion to recognize that the
15 SIGNAL portion is spoofed.

In such a case, a high-grade communication station receiving the packet tries to decode the SIGNAL-2 portion in accordance with both of the first communication method and a communication method which the first communication
20 stations cannot decode, and can recognize that the SIGNAL portion is spoofed by the fact that the SIGNAL-2 portion can be decoded according to the latter method. Then, the high-grade communication station can perform the reception processing of the second decoding portion
25 according to the communication mode obtained from the SIGNAL-2 portion.

The SIGNAL-2 portion is located before the MAC frame being the second decoding portion. Consequently, in the case where the information of a packet length and a
30 transmission rate is spoofed in the first decoding portion, a high-grade communication station receiving the

packet can perform the reception operation of the second decoding portion after the SIGNAL-2 portion on the basis of the true packet length (True Length) and the true transmission rate (True Rate) describe in the SIGNAL-2
5 portion.

A high-grade communication station performing a packet transmission modulates the second communication method decoding portion according to a modulation system known only by each of the high-grade communication
10 stations, and thereby it can be realized that all of the high-grade communication stations can decode the second communication method decoding portion, and that conventional stations cannot decode the second communication method decoding portion. For example, in
15 case of performing a phase modulation of the SIGNAL-2 portion such as BPSK, a phase difference θ , which second communication stations jointly own, may be given to a signal point location, or a signal point may be translated by a known quantity Δd . On the other hand, a
20 high-grade communication station receiving the packet performs the phase demodulation of the packet in consideration of the phase shift of the signal point location such as the phase difference $-\theta$ or the movement quantity $-\Delta d$. Then, the high-grade communication station
25 can know the spoofing of the first decoding portion by the fact that the SIGNAL-2 portion could be decoded.

Fig. 16 shows an example of the inner structure of the wireless reception unit 110 in this case. The wireless reception unit 110 is composed of an RF unit and
30 a PHY portion. The PHY portion is composed of a first demodulation unit, a second demodulation unit, and a

reception processing unit for processing reception data which correctly demodulated by either of these demodulation units.

The reception processing unit notifies the first demodulation unit of the modulation system (transmission rate) obtained from the first decoding portion. The first demodulation unit supposes that the first decoding portion is not spoofed, and demodulates the signal after that according to the modulation system (transmission rate) described in the first decoding portion by the signal point location same as that of the first decoding portion.

The second demodulation unit supposes that the SIGNAL-2 portion follows the first decoding portion, and demodulates the SIGNAL-2 portion according to a known modulation system (transmission rate) by the signal point location whose phase has been rotated by 90 degrees.

The SIGNAL-2 portion has a fixed length. Consequently, when it becomes clear that the portion is the SIGNAL-2 portion after the demodulation of a predetermined length of the SIGNAL-2 portion, it is found that the first decoding portion is spoofed. If not so, it is found that the first decoding portion is not spoofed. In the latter case, the second demodulation unit continues the demodulate at the unrotated signal point location by the first demodulation unit. Thereby, it is possible to suggest whether the spoofing is performed or not without providing any spoofed flag in the reserved area (Reserve) of the first decoding portion.

Incidentally, a modulation system for providing a

phase difference to a signal point on a constellation to perform mapping is, for example, disclosed in Japanese Unexamined Patent Publication No. Hei 11-146025.

The high-grade communication station can decode the
5 second decoding portion (see DATA portion of Fig. 16) in principle, as described above. However, it is supposed that the second decoding portion cannot be decoded when the distance between communication terminals is large, or when a MIMO communication is performed. In such cases,
10 it is possible to estimate how long a packet transmission terminal directs the other terminals to restrain their transmissions by using the first decoding portion (SIGNAL portion in Fig. 16) and the second communication method decoding portion (HT-SIGNAL portion in Fig. 16), both
15 modulated at a fixed low-speed rate.

The value of $(\text{packet length})/(\text{transmission rate})$ calculated on the basis of the description in the SIGNAL portion as the first decoding portion is the duration until the reception of ACK in Fig. 16 is completed.
20 Moreover, the value of $(\text{True Length})/(\text{True Rate})$ calculated on the basis of the HT-SIGNAL portion as the second communication method decoding portion corresponds to the duration until the transmission of a true packet is completed. The difference between the two
25 $(\text{Length})/(\text{Rate})$ (by adding EIF - DIFS in Fig. 16) is a value corresponding to an NAV indicating how long the packet transmission terminal directs the other terminals to restrain their transmissions.

The method of adding the field (SIGNAL-2 portion or
30 HT-SIGNAL portion) as shown in Fig. 4 for specifying a transmission mode to a packet for enabling the mutual

notification of the transmission mode among high-grade communication stations is simple, but the decrease of the overhead and the communication efficiency caused by the transmission data becomes a problem.

5 Now, as described above, in the case where RATE and Length in the SIGNAL portion are set in a pseudo-way, there are a plurality of spoofed combinations of the packet length and the rate for indicating the same period of time. For example, because the period of time
10 necessary for transmitting 1200 bits at 6 Mbps and the period of time necessary for transmitting 2400 bits at 12 Mbps are the same, a reception station does not care which period of time is set as Rate.

 However, in the case where a high-grade
15 communication station uses a high-speed transmission rate which the first communication method cannot deal with, it is necessary that a value corresponding to the first communication method is spoofed in the transmission rate (Rate) field of the SIGNAL portion for enabling the
20 conventional stations to decode the first decoding portion correctly. In this case, it is needed to perform the spoofing by adjusting the value of the packet length (Length) in order to be able to obtain a desired Duration value according to the spoofed transmission rate (Rate)
25 value.

 In the example shown in Fig. 3, in the case where a spoofed flag is set in the SIGNAL portion being the first decoding portion, the high-grade communication stations destroy the information of Rate in the SIGNAL portion as
30 being spoofed. On the other hand, in the example shown in Fig. 4, it is possible to indicate which mode the

successive high-grade modulation system takes by using the information of True Rate described in the SIGNAL-2 portion.

Fig. 5 shows a description example of the Rate field in the IEEE 802.11a. As shown in Fig. 5, the IEEE 802.11a sets eight transmission rates of 6 Mbps, 9 Mbps, 12 Mbps, 18 Mbps, 24 Mbps, 36 Mbps, 48 Mbps and 54 Mbps. In the Rate field, transmission rates are expressed by means of four bits. When a spoofed flag is set, it is possible to assign the definition of the Rate field on a standard to the specifying of an actual high-speed transfer mode.

In the example shown in Fig. 5, though the Rate field is four bits, all of the LSB's are set to be 1. Consequently, it is possible to specify each of 3 bits, i.e. eight modes can be specified. Moreover, the IEEE 802.11b being a conventional standard includes the least upper bound of settable packet length (Length). Consequently, when a higher rank rate is used for spoofing, the Length field is lacked. Then, there is a problem in which a sufficient value of Duration cannot be secured for $(\text{packet length (Length)})/(\text{rate (Rate)})$ (namely, an NAV of a long duration cannot be spoofed). Accordingly, actually four rates of 6 Mbps, 9 Mbps, 12 Mbps, and 18 Mbps are used for the specification of the high-speed transfer mode for enabling the setting of large value Duration $(= (\text{Length})/(\text{Rate}))$. Because there is the possibility that there is a conventional station which, when a Length exceeding the least upper bound is set, recognizes the information as an error and destroys the information, the definition is provided (the IEEE

802.11a indicates the Length information by bits, and the IEEE 802.11b indicates the Length information by periods of time).

Incidentally, because the IEEE 802.11n supposes a system using a multi-input multi-output (MIMO) communication and a system expanding a communication use band as a high-speed transmission, a plurality of transmission modes can exist according to the combination of the number of antennas used for the MIMO communications and communication use bands. In such a case, the transmission mode may be notified among the high-grade communication stations by means of any one of the above-described methods.

Hereupon, the MIMO communication indicates a technique for achieving the increase of a transmission capacity and the improvement of a communication speed by realizing space division multiplexing, i.e. a plurality of logically independent transmission paths, by providing a plurality of antenna elements both at the transmitter side and at the receiver side. Because the MIMO communication uses the space division multiplexing, frequency usability is good.

Next, a reception processing procedure of the wireless communication apparatus 100 in the wireless network according to the present embodiment is described.

Fig. 6 shows a reception processing procedure in the form of a flowchart in the case where the wireless communication apparatus 100 operates as a conventional station. Such a processing procedure is actually realized in a form in which the central control unit 103 executes the instruction executing program stored in the

information storage unit 113.

When the wireless communication apparatus 100 receives a PLCP preamble portion in step S1, the wireless communication apparatus 100 successively receives the
5 SIGNAL portion of the PHY layer in step S2.

Then, the wireless communication apparatus 100 decodes the information of the transmission rate (Rate) and the packet length (Length) described in the SIGNAL portion in step S3, and calculates the reception duration
10 determined by (packet length)/(transmission rate).

Next, the wireless communication apparatus 100 receives a MAC header portion at the transmission rate specified by RATE in the SIGNAL portion in step S4. Now, when the wireless communication apparatus can decode the
15 reception destination address on the basis of the MAC header in step S5, the wireless communication apparatus 100 compares the reception destination address with the local station address in step S6. Then, when both the addresses coincide with each other, the wireless
20 communication apparatus 100 performs the reception processing for the packet length specified by the Length of the SIGNAL portion in step S7.

Moreover, when the reception destination address and the local station address do not coincide with each other
25 in step S6, the wireless communication apparatus 100 raises an NAV for the Duration determined by (packet length)/(transmission rate), and restrains its transmission in step S8.

Moreover, when the wireless communication apparatus
30 100 cannot decode the reception destination address on the basis of the MAC header in step S5, the wireless

communication apparatus 100 performs reception processing for a packet length specified by the Length of the SIGNAL portion in step S7.

Moreover, Fig. 7 shows a reception processing procedure in the form of a flowchart when the wireless communication apparatus 100 operates as a high-grade communication station. Such a processing procedure is actually realized in the form in which the central control unit 103 executes the instruction executing program stored in the information storage unit 113.

When the wireless communication apparatus 100 receives a PLCP preamble portion in step S11, the wireless communication apparatus 100 successively receives the SIGNAL portion of the PHY layer in step S12.

Then, the wireless communication apparatus 100, for example, refers to the spoofed flag in the Reserve field to judge whether the information of the transmission rate (Rate) and the packet length (Length) is spoofed or not in step S13.

Alternatively, the wireless communication apparatus 100 judges whether the SIGNAL-2 portion is provided successively to the SIGNAL portion or not. Thereby, the wireless communication apparatus judges whether the information of the transmission rate (Rate) and the packet length (Length) is spoofed or not in step S13. In this case, the wireless communication apparatus 100 tries to demodulate the SIGNAL-2 portion according to the modulation system which each of the high-grade communication stations knows but the first communication stations do not know in parallel with the wireless communication apparatus 100 demodulates the signal after

the SIGNAL-2 portion according to the modulation system (transmission rate) described in the SIGNAL portion. Then, the wireless communication apparatus 100 can recognized that the SIGNAL portion is spoofed on the basis of the fact the wireless communication apparatus 100 can decode the SIGNAL-2 portion according to the latter modulation system.

Now, when the spoofed flag is not set, the wireless communication apparatus 100 can recognize that the packet is transmitted at the transmission rate at which the conventional stations can receive the packet. Then, the wireless communication apparatus 100 decodes the information of the transmission rate (Rate) and the packet length (Length) described in the SIGNAL portion in step S14, and calculates the reception duration determined by $(\text{packet length}) / (\text{transmission rate})$.

Next, the wireless communication apparatus 100 receives the MAC header portion at the transmission rate specified by the RATE in the SIGNAL portion in step S15. Now, when the wireless communication apparatus can decode the reception destination address on the basis of the MAC header in step S16, the wireless communication apparatus 100 compares the reception destination address with the local station address in step S17. Then, when both the addresses coincide with each other, the wireless communication apparatus 100 performs the reception processing for the packet length specified by the Length of the SIGNAL portion in step S18.

Moreover, when the reception destination address and the local station address do not coincide with each other in step S17, the wireless communication apparatus 100

raises an NAV for the Duration specified by the MAC header, and restrains its transmission in step S19.

Moreover, when the wireless communication apparatus 100 cannot decode the reception destination address on the basis of the MAC header in step S16, the wireless communication apparatus 100 performs reception processing for a packet length specified by the Length of the SIGNAL portion in step S18.

On the other hand, when the wireless communication apparatus 100 judges that the second decoding portion of the packet is transmitted at the transmission rate at which only the high-grade communication stations can receive the packet on the basis of the setting of the spoofed flag in the SIGNAL portion or on the basis of the provision of the SIGNAL-2 portion in step S13, the wireless communication apparatus 100 shifts to a high-speed transmission mode in step S20, and receives the MAC header portion in step S15. The wireless communication apparatus 100 performs the reception processing according to, for example, True Rate and True Length described in the SIGNAL-2 portion.

Now, when the wireless communication apparatus 100 can decode the reception destination address on the basis of the MAC header in step S16, the wireless communication apparatus 100 compares the reception destination address with the local station address in step S17. Then, when both the addresses coincide with each other, the wireless communication apparatus 100 performs the reception processing for the packet length specified by the Length of the SIGNAL portion in step S18.

Moreover, when the reception destination address and

the local station address do not coincide with each other in step S17, the wireless communication apparatus 100 raises an NAV for the Duration determined by (packet length)/(transmission rate), and restrains its
5 transmission in step S19.

Lastly, a communication operation in the wireless network according to the present embodiment is described. In the wireless network, conventional stations in conformity with the conventional IEEE 802.11b and high-
10 grade communication stations in conformity with the IEEE 802.11g corresponding to a high-speed edition standard using the same band as that of the IEEE 802.11b intermixedly operates.

Fig. 8 shows a communication operation example based
15 on CSMA/CA. In the shown example, there are four communication stations #0 to #3 in a communication environment. Among them, the communication station #0 and the communication station #2 are supposed to be high-grade communication stations, and the communication
20 station #2 and the communication station #3 are supposed to be conventional stations.

Each communication station having transmission data monitors a medium state for a predetermined inter frame space DIFS from the last detection of a packet. When any
25 media are clear, namely when there are no transmission signals, the communication station performs random backoff. Furthermore, when there are no transmission signals also in this period, a transmission right is given to the communication station. In the shown
30 example, the communication station #0 setting the random backoff shorter than that of the other peripheral

stations acquires the transmission right, and can start a data transmission to the communication station #1 similarly as a high-grade communication station.

At the time of the data transmission, the transmission source communication station #0 transmits a first decoding portion corresponding to the PHY header according to a first communication method, which all communication stations can receive, and transmits a second decoding portion corresponding to the MAC frame according to a second communication method, which only the high-grade communication stations can receive. Then, the transmission source communication station #0 performs the spoofing of the information of the transmission rate (Rate) and the packet length (Length) in the SIGNAL portion of the PHY header in order that the value of $(\text{packet length})/(\text{rate})$ may be equal to the duration until an ACK packet for which communications are desired to be stopped.

Alternatively, the transmission source communication station #0 transmits the SIGNAL portion in the PHY header according to the first communication method, which all communication stations can receive, and successively transmits the SIGNAL-2 portion modulated according to a modulation system, which each high-grade communication station knows but the first communication stations do not know. After that, the transmission source communication station #0 transmits the second decoding portion corresponding to the MAC frame according to the second communication method, which only the high-grade communication stations can receive. Then, the transmission source communication station #0 performs the

spoofing of the information of the transmission rate (Rate) and the packet length (Length) in the SIGNAL portion of the PHY header in order that the value of (packet length)/(rate) may equal to the duration until the ACK packet for which communications are desired to be stopped.

The communication station #2 and the communication station #3 as the conventional stations can hear the SIGNAL portion of the packet from the communication station #0, and set a packet length and a transmission rate different from the actual state to perform reception for a period of time corresponding to the duration until the transmission of the ACK packet ends. The data packet from the communication station #0 is not transmitted for a period of (packet length)/(rate), but the communication station #2 and the communication station #3 try to receive the data packet and do not start any transmissions. As a result, the communication stations #2 and #3 restrain their transmissions. Moreover, because the rate and the packet length are different from the real transmission of the packet, the rate and the packet cannot be normally decoded, and the communication station #2 and the communication station #3 destroy the packet.

Moreover, in the reserved area (Reserve) of the SIGNAL portion, a spoofed flag indicating the spoofing of the information of the transmission rate (Rate) and the packet length (Length) of the SIGNAL portion is set. In this case, the communication mode of a MAC frame, i.e. the true transmission rate (True Rate) and the true packet length (True Length), is indicated by a

combination of Rate and Length. Alternatively, by providing the SIGNAL-2 portion, the spoofing of the information of the transmission rate (Rate) and the packet length (Length) of the SIGNAL portion is indicated, and the true transmission rate (True Rate) and the true packet length (True Length) of the MAC frame are described.

The communication station #1 being the communication party is a high-grade communication station, and detects the spoofing of the information of a packet length and a rate of a SIGNAL portion on the basis of the spoofed flag. Alternatively, the communication station #1 detects the spoofing of the information of the packet length and the rate of a SIGNAL portion on the basis of the success of the decoding of the SIGNAL-2 portion. Then, the communication station #1 destroys the reception result of the SIGNAL portion in response to the detection of the spoofing. Furthermore, the communication station #1 receives the MAC frame as the successive second decoding portion at the transmission rate indicated by the SIGNAL portion or the SIGNAL-2 portion, and performs the reception operation of the data addressed to the local station for the duration of Duration described in the MAC header. Then, when the data reception is completed, the communication station #1 returns an ACK packet to the data transmission source communication station #0.

In such a way, according to the CSMA/CA system, contention is avoided while a single communication station acquires a transmission right, and any collisions can be avoided by the stop of peripheral stations' data

transmission operations during a data communication operation. Moreover, in case of inexistence of the concealed terminal problem, peripheral stations can raise NAV's to avoid collisions without passing through the
5 RTS/CTS procedure as shown in the drawings. Thereby, overhead can be reduced.

Fig. 9 shows a communication operation example based on RTS/CTS. In the shown example, there are four communication stations #0 to #3 in a communication
10 environment. Among them, the communication station #0 and the communication station #2 are supposed to be high-grade communication stations, and the communication station #2 and the communication station #3 are supposed to be conventional stations.

15 Each communication station is in the following communication state. That is, the communication station #2 can communicate with the adjacent communication station #0, and the communication station #0 can communicate with the adjacent communication stations #1
20 and #2. The communication station #1 can communicate with the adjacent communication stations #0 and #3. The communication station #3 can communicate with the adjacent communication station #1. Furthermore, the communication station #2 is a concealed terminal for the
25 communication station #1, and the communication station #3 is a concealed terminal for the communication station #0.

Each communication station having transmission data monitors a medium state for a predetermined inter frame
30 space DIFS from the last detection of a packet. When any media are clear, namely when there are no transmission

signals, the communication station performs random backoff. Furthermore, when there are no transmission signals also in this period, a transmission right is given to the communication station. In the shown
5 example, the communication station #0 setting the random backoff shorter than that of the other peripheral stations acquires the transmission right, and can start a data transmission to the communication station #1 similarly as a high-grade communication station after the
10 inter frame space DIFS.

That is, the data transmitting communication station #0 transmits a transmission request packet (RTS) to the communication station #1. To this transmission, the reception destination communication station #1 returns a
15 confirmation note (CTS) to the communication station #0 after the shorter inter frame space SIFS (Short IFS).

Now, at the time of an RTS packet, the communication station #0 transmits a first decoding portion corresponding to the PHY header according to a first
20 communication method, which all communication stations can receive, and transmits a second decoding portion corresponding to the MAC frame according to a second communication method, which only the high-grade communication stations can receive. Then, the
25 transmission source communication station #0 performs the spoofing of the information of the transmission rate (Rate) and the packet length (Length) in the SIGNAL portion of the PHY header in order that the value of (packet length)/(rate) may be equal to the duration until
30 an ACK packet for which communications are desired to be stopped.

Alternatively, the transmission source communication station #0 transmits the SIGNAL portion in the PHY header according to the first communication method, which all communication stations can receive, and successively
5 transmits the SIGNAL-2 portion modulated according to a modulation system, which each high-grade communication station knows but the first communication stations do not know. After that, the communication station #0 transmits the second decoding portion corresponding to the MAC
10 frame according to the second communication method, which only the high-grade communication stations can receive. Then, the communication station #0 performs the spoofing of the information of the transmission rate (Rate) and the packet length (Length) in the SIGNAL portion of the
15 PHY header in order that the value of (packet length)/(rate) may equal to the duration until the ACK packet for which communications are desired to be stopped.

The communication station #2 as a conventional
20 station can hear the SIGNAL portion of the RTS packet from the communication station #0, and set a packet length and a transmission rate different from the actual state to perform a reception operation for a period of time corresponding to (packet length)/(rate). The RTS
25 packet from the communication station #0 is not transmitted for a period of (packet length)/(rate), but the communication station #2 tries to receive the data packet and do not start any transmissions. As a result, the communication station #2 restrains its transmission
30 until the transmission of the ACK packet is completed. Moreover, because the rate and the packet length are

different from the real transmission of the packet, the rate and the packet cannot be normally decoded, and the communication station #2 destroys the packet to transmitted according to the second communication method
5 after that.

Moreover, the reception destination communication station #1 transmits the first decoding portion corresponding to the PHY header according to the first communication method, which all communication station can receive, at the time of a transmission of a CTS packet,
10 and transmits the second decoding portion corresponding to the MAC frame according to the second communication method, which only the high-grade communication stations can receive. Then, the communication station #1 performs the spoofing of the information of the transmission rate
15 (Rate) and the packet length (Length) in the SIGNAL portion of the PHY header in order that the value of (packet length)/(rate) may be equal to the duration until the ACK packet for which communications are desired to be
20 stopped.

Alternatively, the reception destination communication station #1 transmits the SIGNAL portion in the PHY header according to the first communication method, which all communication stations can receive, and
25 successively transmits the SIGNAL-2 portion modulated according to a modulation system which each high-grade communication station knows but the first communication stations do not know. After that, the reception destination communication station #1 transmits the second
30 decoding portion corresponding to the MAC frame according to the second communication method, which only the high-

grade communication stations can receive. Then, the reception destination communication station #1 performs the spoofing of the information of the transmission rate (Rate) and the packet length (Length) in the SIGNAL
5 portion of the PHY header in order that the value of (packet length)/(rate) may equal to the duration until the ACK packet for which communications are desired to be stopped.

The communication station #3 as the conventional
10 station can hear the SIGNAL portion of the CTS packet from the communication station #1, and sets a packet length and a transmission rate different from the actual state to perform reception for a period of time corresponding to the duration until the transmission of
15 the ACK packet ends. The CTS packet from the communication station #1 is not transmitted for a period of (packet length)/(rate), but the communication station #3 tries to receive the CTS packet and do not start any transmissions. As a result, the communication station #3
20 restrains its transmission until the completion of the transmission of the ACK packet. Moreover, because the rate and the packet length are different from the real transmission of the packet, the rate and the packet length cannot be normally decoded, and the communication
25 station #3 destroy the packet to be transmitted after that according to the second communication method.

Then the communication station #0 starts the transmission of a data packet in response to the reception of the CTS packet after the inter frame space
30 SIFS.

At the data transmission, the transmission source

communication station #0 transmits the first decoding portion corresponding to the PHY header according to the first communication method, which all communication stations can receive, and also transmits the second
5 decoding portion corresponding to the MAC frame according to the second communication method, which only the high-grade communication stations can receive. Then, the transmission source communication station #0 performs the spoofing of the information of the transmission rate
10 (Rate) and the packet length (Length) in the SIGNAL portion of the PHY header, and sets a spoofed flag indicating the spoofing.

Alternatively, the transmission source communication station #0 transmits the SIGNAL portion in the PHY header
15 according to the first communication method, which all communication stations can receive, and successively transmits the SIGNAL-2 portion modulated according to a modulation system, which each high-grade communication station knows but the first communication stations do not
20 know. After that, the transmission source communication station #0 transmits the second decoding portion corresponding to the MAC frame according to the second communication method, which only the high-grade communication stations can receive. Then, the
25 transmission source communication station #0 performs the spoofing of the information of the transmission rate (Rate) and the packet length (Length) in the SIGNAL portion of the PHY header in order that the value of (packet length)/(rate) may equal to the duration until
30 the ACK packet for which communications are desired to be stopped.

The communication station #1 detects the spoofing of the information of a packet length and a rate of a SIGNAL portion on the basis of the spoofed flag. Alternatively, the communication station #1 detects the spoofing of the information of the packet length and the rate of the SIGNAL portion on the basis of the success of the decoding of a SIGNAL-2 portion. Then, the communication station #1 destroys the reception result of the SIGNAL portion in response to the detection of the spoofing.

5

10 Furthermore, the communication station #1 receives the MAC frame as the successive second decoding portion at the transmission rate indicated by the SIGNAL portion or the SIGNAL-2 portion, and performs the reception operation of the data addressed to the local station for the duration of Duration described in the MAC header.

15 Then, when the reception of the data packet from the communication station #0 is completed, the communication station #1 returns an ACK packet to the data transmission source communication station #0 after the inter frame space SIFS.

20

As described above, when a concealed terminal receives at least one of the RTS and the CTS, the concealed terminal sets a transmission stop duration of the local station for the duration in which the data transmission based on the RTS/CTS procedure is expected to be performed, and thereby collisions can be avoided.

25

However, in the example shown in Fig. 9, in the case where the duration until the end of the RTS/CTS procedure (i.e. the duration until the ACK) is specified as the Duration, peripheral stations must wait until the last even if the RTS/CTS procedure is broken on the way,

30

communication resources are wasted.

Accordingly, also a mechanism called as a Short NAV can be considered. In the Short NAV, each packet of the RTS, the CTS and data secures only the end of the next
5 packet as the Duration. For example, the RTS packet is secured until the end of the CTS packet; the CTS packet is secured until the end of the data packet; the data packet is secured until the end of the ACK packet severally as the Duration. Consequently, even if the
10 RTS/CTS procedure is broken halfway, the peripheral stations are not required to wait until the last.

Fig. 10 shows a communication operation example based on the RTS/CTS using the Short NAV. Incidentally, in the shown example, a communication environment similar
15 to one shown in Fig. 9 is supposed.

Each communication station having transmission data monitors a medium state for a predetermined inter frame space DIFS from the last detection of a packet. When any media are clear, namely when there are no transmission
20 signals, the communication station performs random backoff. Furthermore, when there are no transmission signals also in this period, a transmission right is given to the communication station. In the shown example, after the inter frame space DIFS, the
25 communication station #0, which has the random backoff set to be shorter than that of the other peripheral stations, acquires the transmission right to be able to start a data transmission to the communication station #1.

30 That is, the communication station #0, which transmits data, transmits a transmission request packet

(RTS) to the communication station #1. On the other hand, the communication station #1 being the reception destination returns a confirmation note (CTS) to the communication station #0 after a shorter inter frame space Short IFS (SIFS).

Now, at the time of an RTS packet, the communication station #0 transmits a first decoding portion corresponding to the PHY header according to a first communication method, which all communication stations can receive, and transmits a second decoding portion corresponding to the MAC frame according to a second communication method, which only the high-grade communication stations can receive. Then, the transmission source communication station #0 performs the spoofing of the information of the transmission rate (Rate) and the packet length (Length) in the SIGNAL portion of the PHY header in order that the value of $(\text{packet length})/(\text{rate})$ may be equal to the duration until an CTS packet.

Alternatively, the transmission source communication station #0 transmits the SIGNAL portion in the PHY header according to the first communication method, which all communication stations can receive, and successively transmits the SIGNAL-2 portion modulated according to a modulation system, which each high-grade communication station knows but the first communication stations do not know. After that, the communication station #0 transmits the second decoding portion corresponding to the MAC frame according to the second communication method, which only the high-grade communication stations can receive. Then, the communication station #0 performs the spoofing

of the information of the transmission rate (Rate) and the packet length (Length) in the SIGNAL portion of the PHY header in order that the value of (packet length)/(rate) may equal to the duration for which
5 communications are desired to be stopped.

The communication station #2 as a conventional station can hear the SIGNAL portion of the RTS packet from the communication station #0, and set a packet length and a transmission rate different from the actual
10 state to perform a reception operation for a period of time corresponding to (packet length)/(rate). The RTS packet from the communication station #0 is not transmitted for a period of (packet length)/(rate), but the communication station #2 tries to receive the data
15 packet and do not start any transmissions. As a result, the communication station #2 restrains its transmission until the transmission of the CTS packet is completed. Moreover, because the rate and the packet length are different from the real transmission of the packet, the
20 rate and the packet cannot be normally decoded, and the communication station #2 destroys the packet to transmitted according to the second communication method after that.

Moreover, the reception destination communication
25 station #1 transmits the first decoding portion corresponding to the PHY header according to the first communication method, which all communication station can receive, at the time of a transmission of a CTS packet, and transmits the second decoding portion corresponding
30 to the MAC frame according to the second communication method, which only the high-grade communication stations

can receive. Then, the communication station #1 performs the spoofing of the information of the transmission rate (Rate) and the packet length (Length) in the SIGNAL portion of the PHY header in order that the value of
5 (packet length)/(rate) may be equal to the duration until the data packet.

Alternatively, the reception destination communication station #1 transmits the SIGNAL portion in the PHY header according to the first communication
10 method, which all communication stations can receive, and successively transmits the SIGNAL-2 portion modulated according to a modulation system which each high-grade communication station knows but the first communication stations do not know. After that, the reception
15 destination communication station #1 transmits the second decoding portion corresponding to the MAC frame according to the second communication method, which only the high-grade communication stations can receive. Then, the reception destination communication station #1 performs
20 the spoofing of the information of the transmission rate (Rate) and the packet length (Length) in the SIGNAL portion of the PHY header in order that the value of (packet length)/(rate) may equal to the duration until the data packet for which communications are desired to
25 be stopped.

The communication station #3 as the conventional station can hear the SIGNAL portion of the CTS packet from the communication station #1, and sets a packet length and a transmission rate different from the actual
30 state to perform reception for a period of time corresponding to (packet length)/(rate). The CTS packet

from the communication station #1 is not transmitted for a period of $(\text{packet length})/(\text{rate})$, but the communication station #3 tries to receive the CTS packet and do not start any transmissions. As a result, the communication station #3 restrains its transmission until the completion of the transmission of the data packet. Moreover, because the rate and the packet length are different from the real transmission of the packet, the rate and the packet length cannot be normally decoded, and the communication station #3 destroy the packet to be transmitted after that according to the second communication method.

Then the communication station #0 starts the transmission of a data packet in response to the reception of the CTS packet after the inter frame space SIFS.

At the data transmission, the transmission source communication station #0 transmits the first decoding portion corresponding to the PHY header according to the first communication method, which all communication stations can receive, and also transmits the second decoding portion corresponding to the MAC frame according to the second communication method, which only the high-grade communication stations can receive. Then, the transmission source communication station #0 performs the spoofing of the information of the transmission rate (Rate) and the packet length (Length) in the SIGNAL portion of the PHY header in order that the value of $(\text{packet length})/(\text{rate})$ may be equal to the duration of Duration until the ACK packet, and sets a spoofed flag indicating the spoofing.

Alternatively, the transmission source communication station #0 transmits the SIGNAL portion in the PHY header according to the first communication method, which all communication stations can receive, and successively
5 transmits the SIGNAL-2 portion modulated according to a modulation system, which each high-grade communication station knows but the first communication stations do not know. After that, the transmission source communication station #0 transmits the second decoding portion
10 corresponding to the MAC frame according to the second communication method, which only the high-grade communication stations can receive. Then, the transmission source communication station #0 performs the spoofing of the information of the transmission rate
15 (Rate) and the packet length (Length) in the SIGNAL portion of the PHY header in order that the value of $(\text{packet length})/(\text{rate})$ may equal to the duration until the ACK packet for which communications are desired to be stopped.

20 The communication station #2 as a conventional station can hear the SIGNAL portion of the RTS packet from the communication station #0, and set a packet length and a transmission rate different from the actual state to perform a reception operation for a period of
25 time corresponding to $(\text{packet length})/(\text{rate})$. The data packet from the communication station #0 is not transmitted for a period of $(\text{packet length})/(\text{rate})$, but the communication station #2 tries to receive the data packet and do not start any transmissions. As a result,
30 the communication station #2 restrains its transmission until the transmission of the ACK packet is completed.

Moreover, because the rate and the packet length are different from the real transmission of the packet, the rate and the packet cannot be normally decoded, and the communication station #2 destroys the packet to
5 transmitted according to the second communication method after that.

When the communication station #1 detects the spoofing of the information of the packet length and the rate of a SIGNAL portion on the basis of the spoofed
10 flag, the communication station #1 destroys the information. Furthermore, the communication station #1 receives the MAC frame as the successive second decoding portion at the corresponding transmission rate, and performs the reception operation of the data addressed to
15 the local station for the duration of Duration described in the MAC header. Then, when the reception of the data packet from the communication station #0 is completed, the communication station #1 returns an ACK packet to the data transmission source communication station #0 after
20 the inter frame space SIFS.

As described above, when a concealed terminal receives at least one of the RTS and the CTS, the concealed terminal sets a transmission stop duration of the local station for the duration in which the
25 transmission of the next packet is expected to be completed, and thereby collisions can be avoided.

As described above, in the present embodiment, the high-grade communication stations perform the spoofing of the description of the SIGNAL portion of the PHY header,
30 and provide the transmission stop duration to the conventional stations until a transaction according to

the high-grade communication method ends to obtain compatibility. That is, the conventional stations unable to deal with the high-grade communication method stop their transmissions for the duration in which the transmission of the next packet is expected to end, and thereby collisions can be avoided.

In the examples shown in Figs. 8 and 9, in a communication procedure executed according to the second communication method, the spoofing of the description of the SIGNAL portion is performed in order that the conventional stations may stop their transmission operations for the duration until the ACK transmission ends. Moreover, when a packet transmission is performed according to a communication procedure to perform multiple connections with a plurality of communication stations in the MAC frame according to the second communication system, the ACK (response packet) transmission is performed in a time division multiplex from each remote station. Also in this case, the above-mentioned mechanism can be applied. Moreover, the transmission of the ACK packet hereupon is not limited to the case of single ACK packet, but includes, for example, the case where the ACK packet is multiplexed with other kinds of packets such as an RTS packet, a CTS packet and data packet to be transmitted.

Fig. 17 shows communication operation sequencing in which a plurality of reception stations replies by a response packet in time division to a transmission packet from a transmission station.

A packet #0 transmitted from the communication station #0 is supposed to request a reply from the

communication station #1 and the communication station #2 severally. The packet #0 notifies the communication station #1 and the communication station #2 of the timing of the transmissions of their response packets lest the response packets should collide.

At this time, the value of (packet length)/(rate) of the SIGNAL portion of the packet #0 is set to be the time when the receptions of all response packets have been completed. Thereby, it is prevented that the communication station #3 locating at a position distant from the communication station #1 and communication station #2 to the degree of unable to receiving the response packets from the communication stations #1 and #2 disturbs the responses. Because the SIGNAL portion is transmitted at the lowest rate, such setting is effective to eliminate such a concealed terminal.

Incidentally, Japanese Patent Application No. 2003-297919, which has been assigned to the present applicant already, discloses a communication system in which a transmission station transmits a data frame addressed to a plurality of reception stations in the space division multiple access (SDMA) and each reception station reply by ACK in the time division multiplex.

In the above, specific embodiments have been referred to while the present invention has been described in detail. However, it is clear that the person skilled in the art can modify and substitute the embodiments without departing from the scope and spirit of the present invention. That is, the present invention has been disclosed in the form of exemplifying, and the contents of the description of the present specification

should not be interpreted limitedly. For the judgment of the subject matter of the present invention, claims should be considered.

5 This application claims priority from Japanese Priority Document No. 2004-196837, filed on Jul. 2, 2004 with the Japanese Patent Office, which document is hereby incorporated by reference.

CLAIMS

1. A wireless communication system in which a first communication station operating according to a first communication method and a second communication station operable according to both the first communication method and a second communication method coexist, wherein

5 said second communication station transmits a packet composed of a first decoding portion receivable according to said first communication method, and a second decoding portion receivable according to said second communication method.

2. The wireless communication system as cited in claim 1, wherein;

15 said first decoding portion includes information related to a packet length and a transmission rate of the packet; and

20 said first communication station receiving the packet calculates $(\text{packet length})/(\text{transmission rate})$ on the basis of the packet length and the transmission rate of the packet obtained by decoding said first decoding portion in order to obtain a reception period of time for the packet.

25 3. The wireless communication system as cited in claim 2, wherein;

30 when said second communication station performs a communication procedure according to said second communication method, the second communication station describes spoofed information of a packet length and a

transmission rate in the first decoding portion to designate a duration by (packet length)/(transmission rate) in order to stop the communication operation of the other stations for the communication procedure within the
5 duration.

4. The wireless communication system as cited in claim 2, wherein;

10 said second communication station performing a packet transmission spoofs about the information of the packet length and the transmission rate to be described in the first decoding portion in order that the first communication station receiving the packet stops its communication operation for the duration until a
15 communication transaction to be performed according to the second communication method ends.

5. The wireless communication system as cited in claim 2, wherein;

20 said second communication station performing a packet transmission spoofs about the information of the packet length and the transmission rate to be described in the first decoding portion in order that the first communication station receiving the packet stops its
25 communication operation for the duration until an ACK transmission ends in a communication procedure preformed according to the second communication method.

6. The wireless communication system as cited in claim 2,
30 wherein;

when said second communication station carries out a

packet transmission in accordance with a communication procedure to perform multiple connections with a plurality of communication stations in the second decoding portion, said second communication station
5 spoofs information of a packet length and a transmission rate so that the first communication station receiving the packet stops the communication operation in a duration until all of the ACK transmissions performed in a time division multiplex from each remote station end.
10 the duration indicates the duration

7. The wireless communication system as cited in one of claims 3 to 6, wherein;

said second communication station performing the
15 packet transmission describes whether the spoofed information of a packet length and a transmission rate is described in the first decoding portion or not in the packet in a format which the second communication station operating according to the second communication method
20 can decode but the first communication station operating according to the first communication method cannot decode.

8. The wireless communication system as cited in claim 7,
25 wherein;

said second communication station performing the packet transmission indicates in the first decoding portion whether the spoofed information of a packet length and a transmission rate is described or not.
30

9. The wireless communication system as cited in one of

claims 3 to 6, wherein;

when said second communication station detects that the information of a packet length and a transmission rate in the first decoding portion of the packet received from another station is spoofed, said second communication station switches its reception method to the second communication method to perform the reception operation of the residual portion of the packet.

10 10. The wireless communication system as cited in claim 2, wherein;

said second communication method includes a plurality of communication modes;

15 said second communication station performing a packet transmission is provided with a known second communication method decoding portion which the second communication station can decode, in the packet; and

the communication mode is represented by the second communication method decoding portion.

20

11. The wireless communication system as cited in claim 10, wherein;

25 said second communication station performing a packet transmission transmits the second communication method decoding portion in a communication method in which the second communication station operating in the second communication method can decode the second communication method decoding portion, but the first communication station operating in the first communication method cannot decode.

30

12. The wireless communication system as cited in claim 10, wherein;

the second communication station performing the packet transmission locates the second communication method decoding portion before the second decoding portion in the packet, and describes the information related to an actual packet length and a transmission rate in the second decoding portion within the second communication method decoding portion, when the spoofed information of a packet length and a transmission rate for the first communication station is described in the first decoding portion,

13. The wireless communication system as cited in claim 12, wherein;

said second communication station receiving the packet can perform the reception operation of the second decoding portion after the second communication method decoding portion of the received packet on the basis of the information related to the packet length and the transmission rate described in the second communication method decoding portion.

14. The wireless communication system as cited in claim 12, wherein;

said second communication station receiving the packet tries to perform the reception operation of the second decoding portion on the basis of the information related to a packet length and a transmission rate described in the second communication method decoding portion of the received packet, and when the second

communication station cannot decode the second decoding portion, the second communication station restrains the transmission of the packet for a predetermined period of time by taking a difference between a period of time
5 obtained from the spoofed packet length and the transmission rate described in the first decoding portion and a period of time obtained from the packet and the transmission rate described in the second communication method decoding portion.

10

15. The wireless communication system as cited in claim 12, wherein;

said second communication station receiving the packet tries to decode the second communication method
15 decoding portion with both the first communication method and the communication method that the first communication station cannot decode, and performs the reception operation with the obtained communication mode when said second communication station can decode with the latter
20 communication method.

16. The wireless communication system as cited in claim 2, wherein;

said second communication method includes a
25 plurality of communication modes; and

said second communication station represents the communication mode with a combination of a packet length and a transmission rate designating the same communication stop period.

30

17. A wireless communication apparatus operating under a

communication environment in which a first communication method and a second communication method coexist, comprising:

5 communication unit for performing transmission and reception of a wireless data by said first communication method and said second communication method on a communication channel;

a packet generation unit for generating a transmission packet of own station;

10 a packet decoding unit for decoding a received packet from another station; and

a control unit for controlling communication operation, wherein;

15 said control unit transmits a first decoding portion of the transmission packet with the first communication method, and transmits a second decoding portion of the transmission packet with the second communication method.

18. The wireless communication apparatus as cited in claim 17, wherein;

20 the first decoding portion of the received packet is decoded and analyzed with the first communication method; and

25 the second decoding portion of the received packet is decoded and analyzed with the second communication method.

19. The wireless communication apparatus as cited in claim 17, wherein;

30 said packet generation unit describes information related to a packet length and a transmission rate of the

packet in the first decoding portion.

20. The wireless communication apparatus as cited in claim 19, wherein;

5 when transmitting said second decoding portion according to said second communication method, said packet generation unit describes spoofed information of a packet length and a transmission rate in the first decoding portion to designate a duration by (packet
10 length)/(transmission rate) in order to stop the communication operation of the other stations for the communication procedure within the duration.

21. The wireless communication apparatus as cited in
15 claim 17, wherein;

 when transmitting said second decoding portion according to said second communication method, said packet generation unit describes spoofed information of the packet length and the transmission rate in the first
20 decoding portion in order that the first communication station receiving the packet stops its communication operation for the duration until a communication transaction to be performed according to the second communication method ends.

25

22. The wireless communication apparatus as cited in claim 17, wherein;

 when transmitting said second decoding portion according to said second communication method, said
30 packet generation unit describes spoofed information of a packet length and a transmission rate in the first

decoding portion in order that the first communication station receiving the packet stops its communication operation for the duration until an ACK transmission in a communication procedure performed according to the second
5 communication method ends.

23. The wireless communication apparatus as cited in claim 17, wherein;

when a packet transmission is performed in accordance with a communication procedure to perform
10 multiple connections with a plurality of communication stations in the second decoding portion, said packet generation unit describes spoofed information of a packet length and a transmission rate in the first decoding
15 portion in order that the first communication station receiving the packet stops its communication operation for the duration until an ACK transmission in a communication procedure performed according to the second communication method ends.

20

24. The wireless communication apparatus as cited in one of claims 20 to 23, wherein;

said packet generation unit describes whether the spoofed information of a packet length and a transmission
25 rate is described in the first decoding portion or not in the packet in a format which the second communication station operating according to the second communication method can decode but the first communication station operating according to the first communication method
30 cannot decode.

25. The wireless communication apparatus as cited in claim 24, wherein;

said packet generation unit indicates whether the spoofed information of the packet length and the transmission rate is described or not in the first decoding portion.

26. The wireless communication apparatus as cited in one of claims 20 to 23, wherein;

10 when said packet generation unit detects that the information of the packet length and the transmission rate in the first decoding portion of the packet received from another station is spoofed, said control unit switches its reception method to the second communication method to perform the reception operation of the residual portion of the packet.

27. The wireless communication apparatus as cited in one of claims 20 to 23, wherein;

20 said second communication method includes a plurality of communication modes;

said packet generation unit is provided with a known second communication method decoding portion which the second communication station can decode, in the packet; and

25 the communication mode is represented by the second communication method decoding portion.

28. The wireless communication apparatus as cited in claim 27, wherein;

30 said control unit transmits the second communication

method decoding portion in a communication method in which the second communication station operating in the second communication method can decode the second communication method decoding portion, but the first
5 communication station operating in the first communication method cannot decode.

29. The wireless communication apparatus as cited in claim 27, wherein;

10 said packet generation unit locates the second communication method decoding portion before the second decoding portion in the packet, and describes the information related to an actual packet length and a transmission rate in the second decoding portion within
15 the second communication method decoding portion, when the spoofed information of a packet length and a transmission rate for the first communication station is described in the first decoding portion,

20 30. The wireless communication apparatus as cited in claim 29, wherein;

 said control unit performs the reception operation of the second decoding portion after the second communication method decoding portion of the received
25 packet on the basis of the information related to the packet length and the transmission rate described in the second communication method decoding portion.

31. The wireless communication apparatus as cited in
30 claim 29, wherein;

 said control unit tries to perform the reception

operation of the second decoding portion on the basis of the information related to a packet length and a transmission rate described in the second communication method decoding portion of the received packet, and when
5 said control unit cannot decode the second decoding portion, said control unit restrains the transmission of the packet for a predetermined period of time by taking a difference between a period of time obtained from the spoofed packet length and the transmission rate described
10 in the first decoding portion and a period of time obtained from the packet and the transmission rate described in the second communication method decoding portion.

15 32. The wireless communication apparatus as cited in claim 26, wherein;

said control unit tries to decode the second communication method decoding portion with both the first communication method and the communication method that
20 the first communication station cannot decode, and performs the reception operation with the obtained communication mode when said control unit can decode with the communication method.

25 33. The wireless communication apparatus as cited in one of claims 20 to 23, wherein;

said second communication method includes a plurality of communication modes; and

said packet generation unit represents the
30 communication mode with a combination of a packet length and a transmission rate designating the same

communication stop period.

34. A wireless communication method for carrying out wireless communication operation under a communication environment in which a first communication method and a
5 second communication method coexist, comprising:

communication unit for performing transmission and reception of a wireless data by said first communication method and said second communication method on a channel;

10 a packet generation step for generating a transmission packet including a first decoding portion and a second decoding portion; and

a packet transmission step for transmitting said first decoding portion of the transmission packet with
15 the first communication method, and transmitting said second decoding portion of the transmission packet with the second communication method.

35. The wireless communication method as cited in claim
20 34, further comprising;

a packet receiving step for receiving and analyzing the first decoding portion of the received packet from another station with the first communication method; and

25 a second receiving step for receiving and analyzing the second decoding portion of the received packet with the second communication method.

36. The wireless communication method as cited in claim
35, wherein;

30 said packet generation step describes information related to a packet length and a transmission rate of the

packet in the first decoding portion.

37. The wireless communication apparatus as cited in claim 36, wherein;

5 when transmitting said second decoding portion according to said second communication method at said packet transmission step, said packet generation step describes spoofed information of a packet length and a transmission rate in the first decoding portion to
10 designate a duration by (packet length)/(transmission rate) in order to stop the communication operation of the other stations for the communication procedure within the duration.

15 38. The wireless communication method as cited in claim 36, wherein;

 when transmitting said second decoding portion according to said second communication method at said packet transmission step, said packet generation step
20 describes spoofed information of the packet length and the transmission rate in the first decoding portion in order that the first communication station receiving the packet stops its communication operation for the duration until a communication transaction to be performed
25 according to the second communication method ends.

39. The wireless communication method as cited in claim 36, wherein;

 when transmitting said second decoding portion
30 according to said second communication method at said packet transmission step, said packet generation step

describes spoofed information of the packet length and the transmission rate in the first decoding portion in order that the first communication station receiving the packet stops its communication operation for the duration
5 until an ACK transmission in a communication procedure performed according to the second communication method ends.

40. The wireless communication method as cited in claim
10 36, wherein;

when a packet transmission is performed in accordance with a communication procedure to perform multiple connections with a plurality of communication stations in the second decoding portion at said packet
15 transmission step, said packet generation step describes spoofed information of the packet length and the transmission rate in the first decoding portion in order that the first communication station receiving the packet stops its communication operation for the duration until
20 an ACK transmission in a communication procedure performed according to the second communication method ends.

41. The wireless communication method as cited in one of
25 claims 37 to 40, wherein;

said packet generation step describes whether the spoofed information of a packet length and a transmission rate is described in the first decoding portion or not in the packet in a format which the second communication
30 station operating according to the second communication method can decode but the first communication station

operating according to the first communication method cannot decode.

42. The wireless communication method as cited in claim
5 41, wherein;

said packet generation step describes whether the spoofed information of the packet length and the transmission rate is described or not in the first decoding portion.

10

43. The wireless communication method as cited in one of claims 37 to 40, wherein;

when detected that the information of the packet length and the transmission rate in the first decoding
15 portion of the packet received from another station is spoofed, said second packet receiving step carries out its reception to perform the reception operation of the residual portion of the packet.

20 44. The wireless communication method as cited in one of claims 37 to 40, wherein;

said second communication method includes a plurality of communication modes;

25 said packet generation step is provided with a known second communication method decoding portion which the second communication station can decode, in the packet; and

the communication mode is represented by the second communication method decoding portion.

30

45. The wireless communication method as cited in claim

44, wherein;

said packet transmission step transmits the second communication method decoding portion in a communication method in which the second communication station operating in the second communication method can decode the second communication method decoding portion, but the first communication station operating in the first communication method cannot decode.

46. The wireless communication method as cited in claim 44, wherein;

said packet generation step locates the second communication method decoding portion before the second decoding portion in the packet, and describes the information related to an actual packet length and a transmission rate in the second decoding portion within the second communication method decoding portion, when a spoofed information of a packet length and a transmission rate for the first communication station is described in the first decoding portion,

47. The wireless communication method as cited in claim 46, wherein;

said second packet receiving step performs the reception operation of the second decoding portion after the second communication method decoding portion of the received packet on the basis of the information related to the packet length and the transmission rate described in the second communication method decoding portion.

30

48. The wireless communication method as cited in claim

46, wherein;

said second packet receiving step tries to perform the reception operation of a second decoding portion on the basis of the information related to a packet length and a transmission rate described in the second communication method decoding portion of the received packet, and when said control unit cannot decode the second decoding portion, said control unit restrain the transmission of a packet for a predetermined period of time by taking a difference between a period of time obtained from the spoofed packet length and the transmission rate described in the first decoding portion and a period of time obtained from the packet and the transmission rate described in the second communication method decoding portion.

49. The wireless communication method as cited in claim 44, wherein;

said first communication station tries to decode the second communication method decoding portion with the communication method that the first communication station cannot decode, and performs the reception operation with the obtained communication mode at said second packet receiving step when said first communication station can decode with the communication method.

50. The wireless communication method as cited in one of claims 37 to 40, wherein;

said second communication method includes a plurality of communication modes; and

said packet generation step represents the

communication mode with a combination of a packet length and a transmission rate designating the same communication stop period.

5 51. A computer program described in a computer readable form for executing on a computer system processing for a wireless communication operation under a wireless communication environment in which a first communication method and a second communication method coexist, said
10 computer program including the steps of:

a packet generating step for generating a transmission packet composed of a first decoding portion and a second decoding portion;

a packet transmitting step for transmitting a first
15 decoding portion of the transmission packet according to the first communication method, and transmitting a second decoding portion of the transmission packet according to the second communication method;

a packet receiving step for receiving and analyzing
20 the first decoding portion of the received packet from another station; and

a second packet receiving step for receiving and analyzing the second decoding portion of the received packet according to the second communication method.

25

FIG. 1

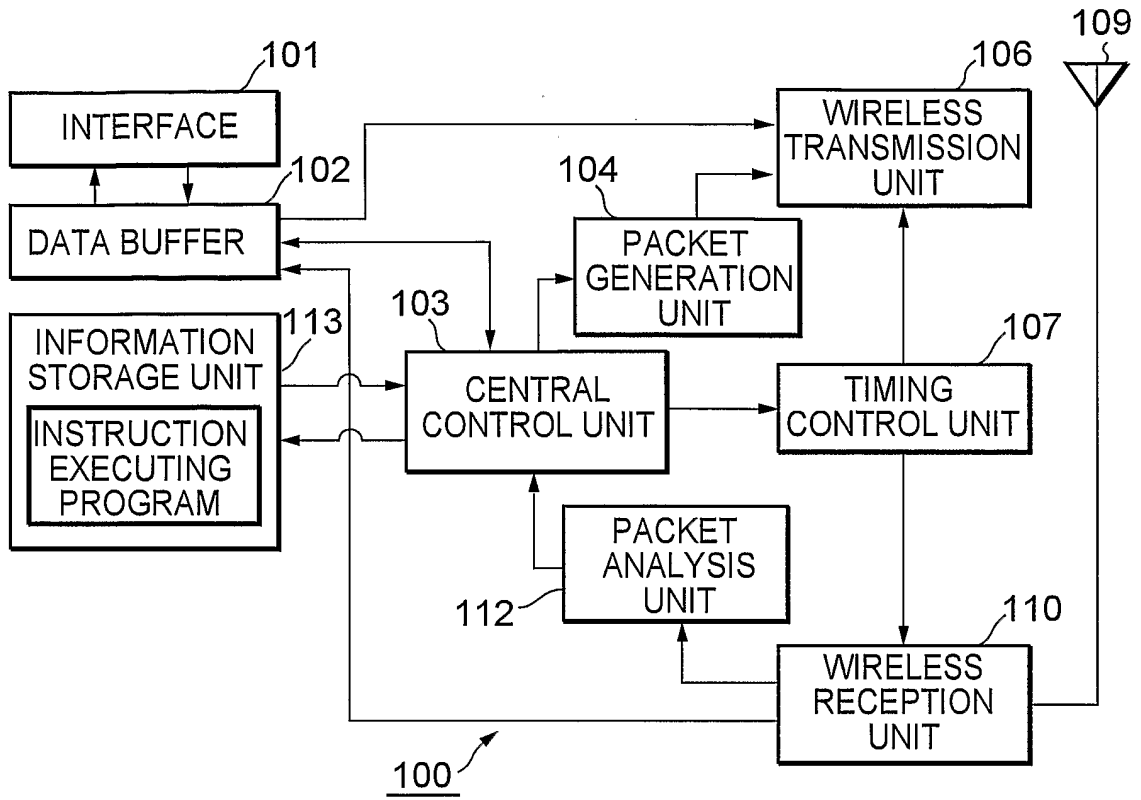

FIG. 2

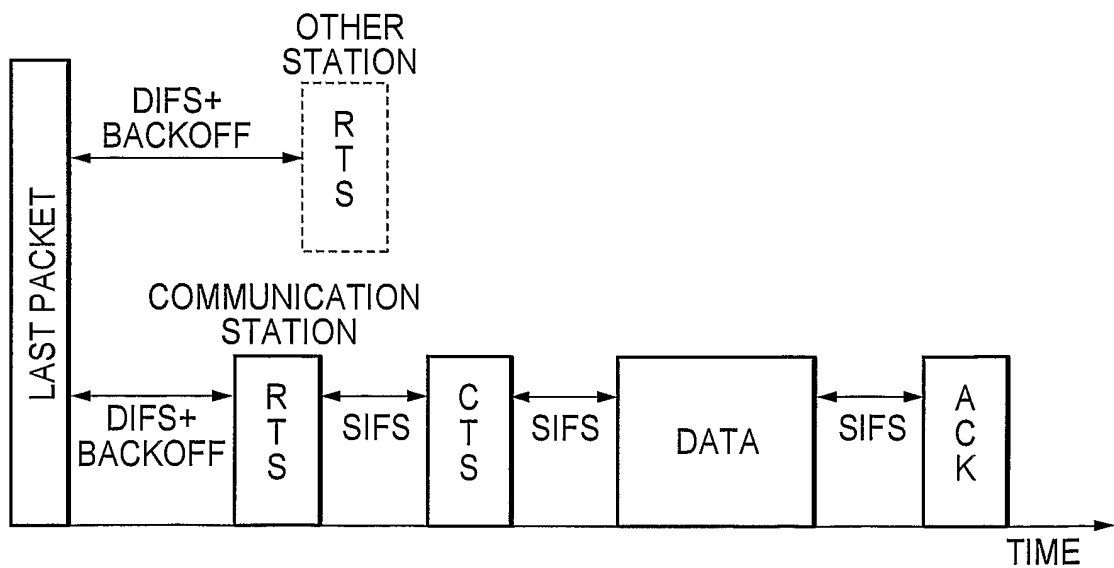

FIG. 3

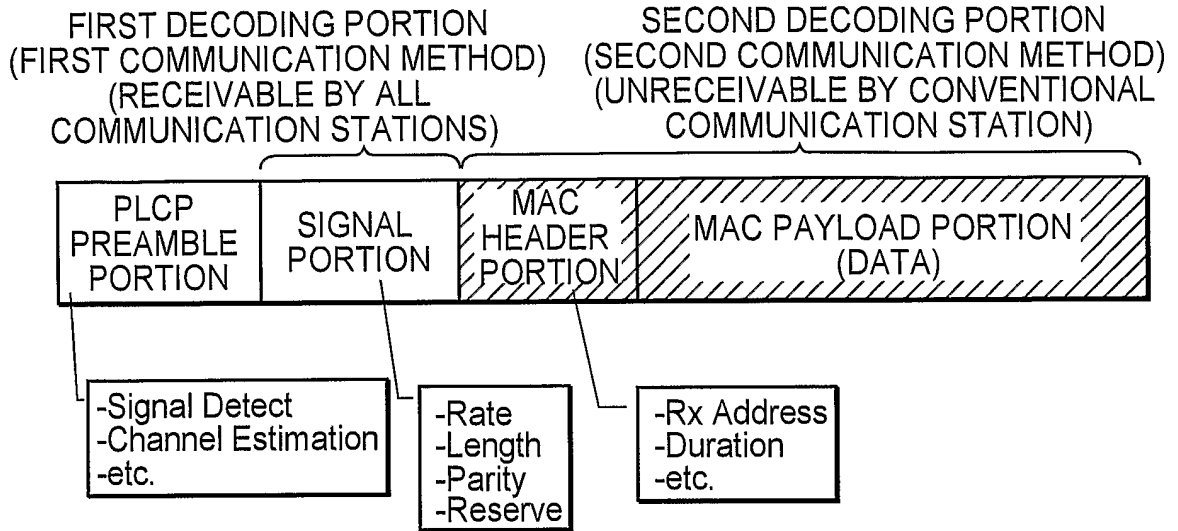

FIG. 4

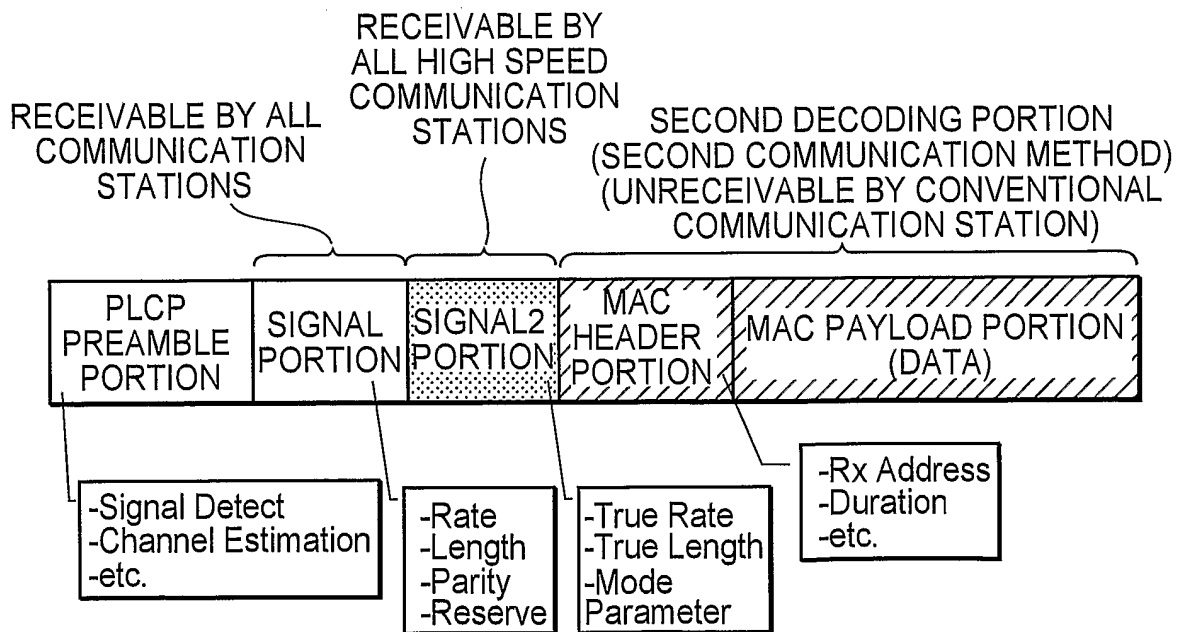

FIG. 5

RATE	1 BIT	2 BIT	3 BIT	4 BIT
6	1	1	0	1
9	1	1	1	1
12	0	1	0	1
18	0	1	1	1
24	1	0	0	1
36	1	0	1	1
48	0	0	0	1
54	0	0	1	1

FIG. 6

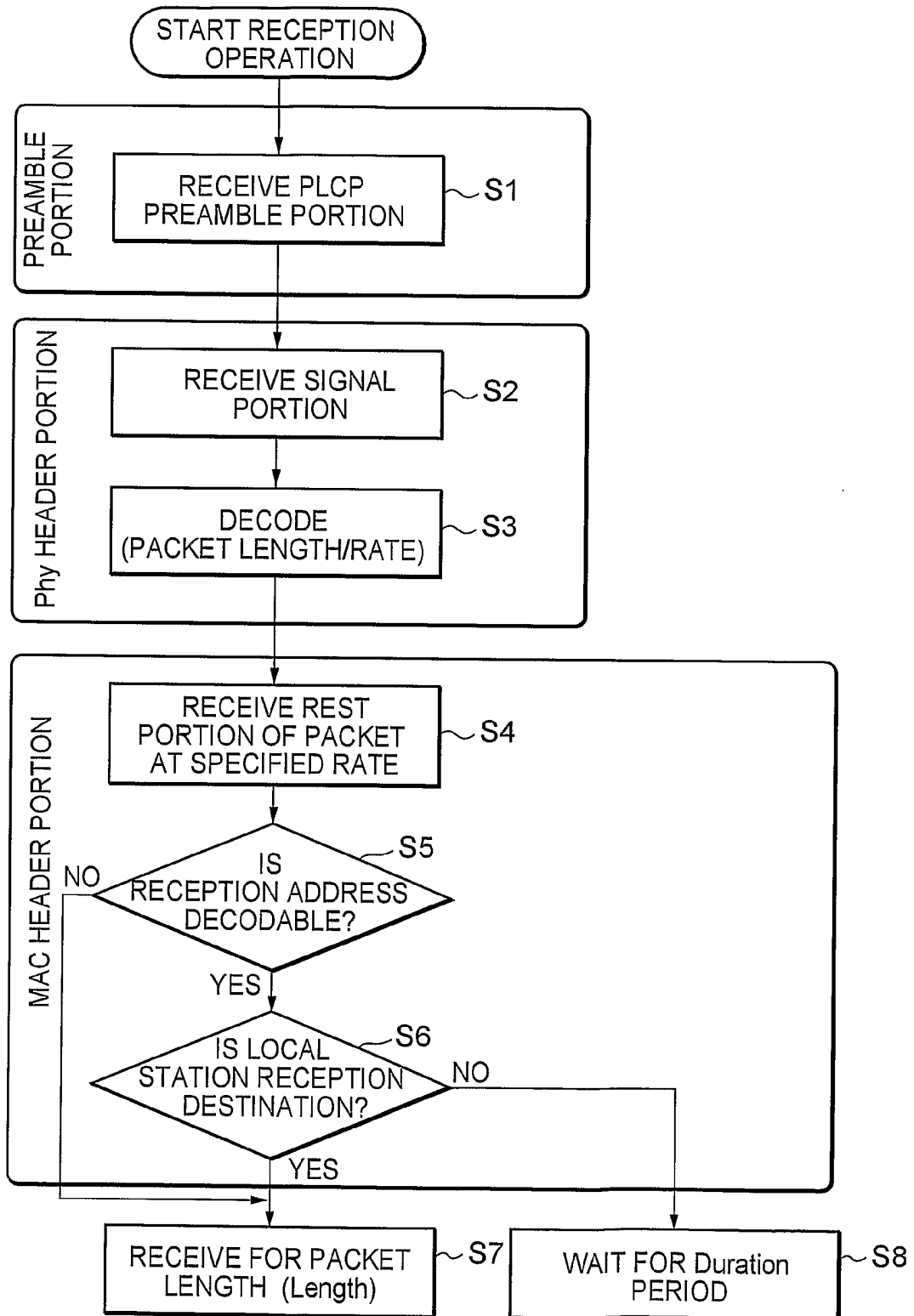

FIG. 7

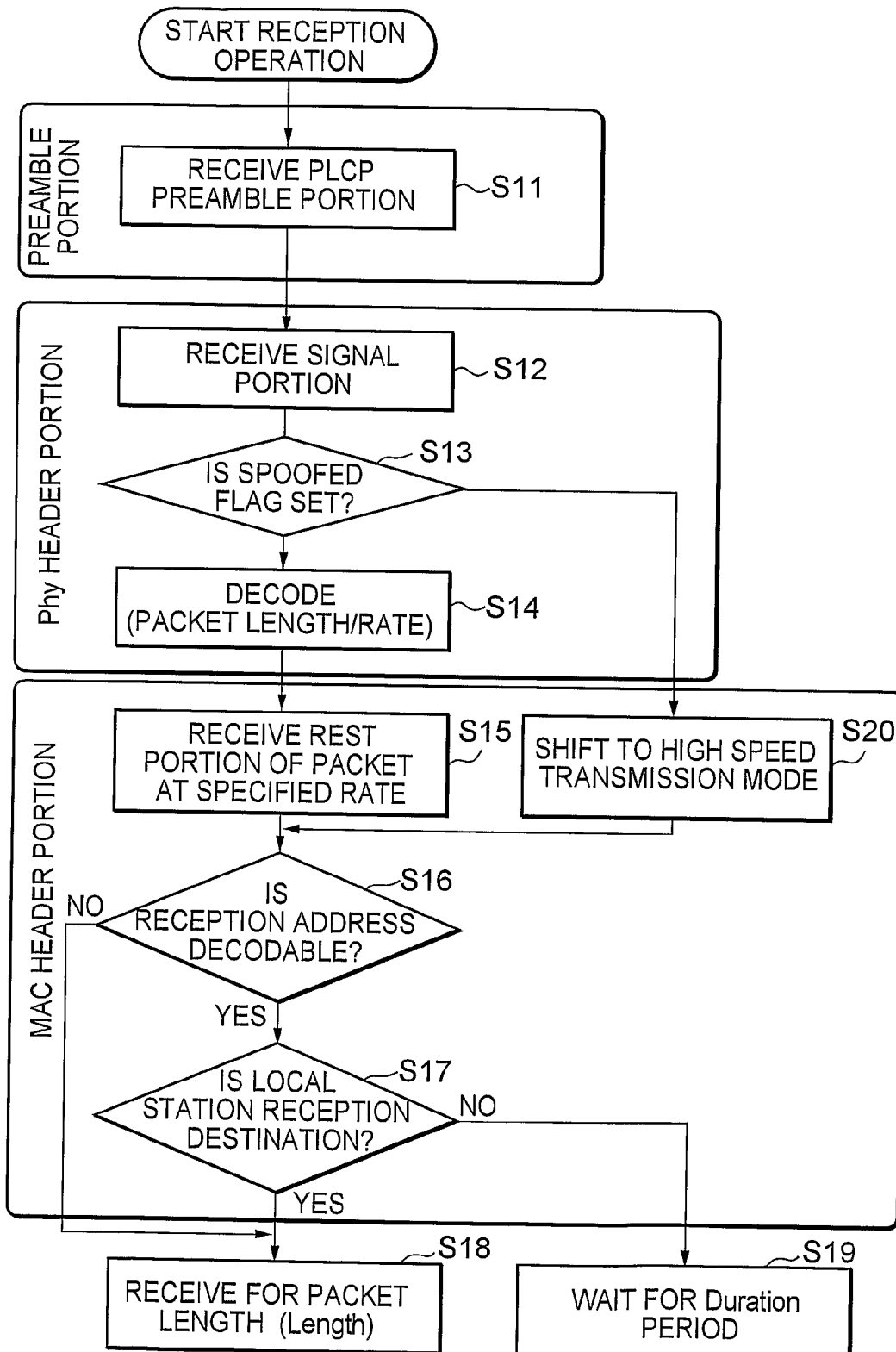
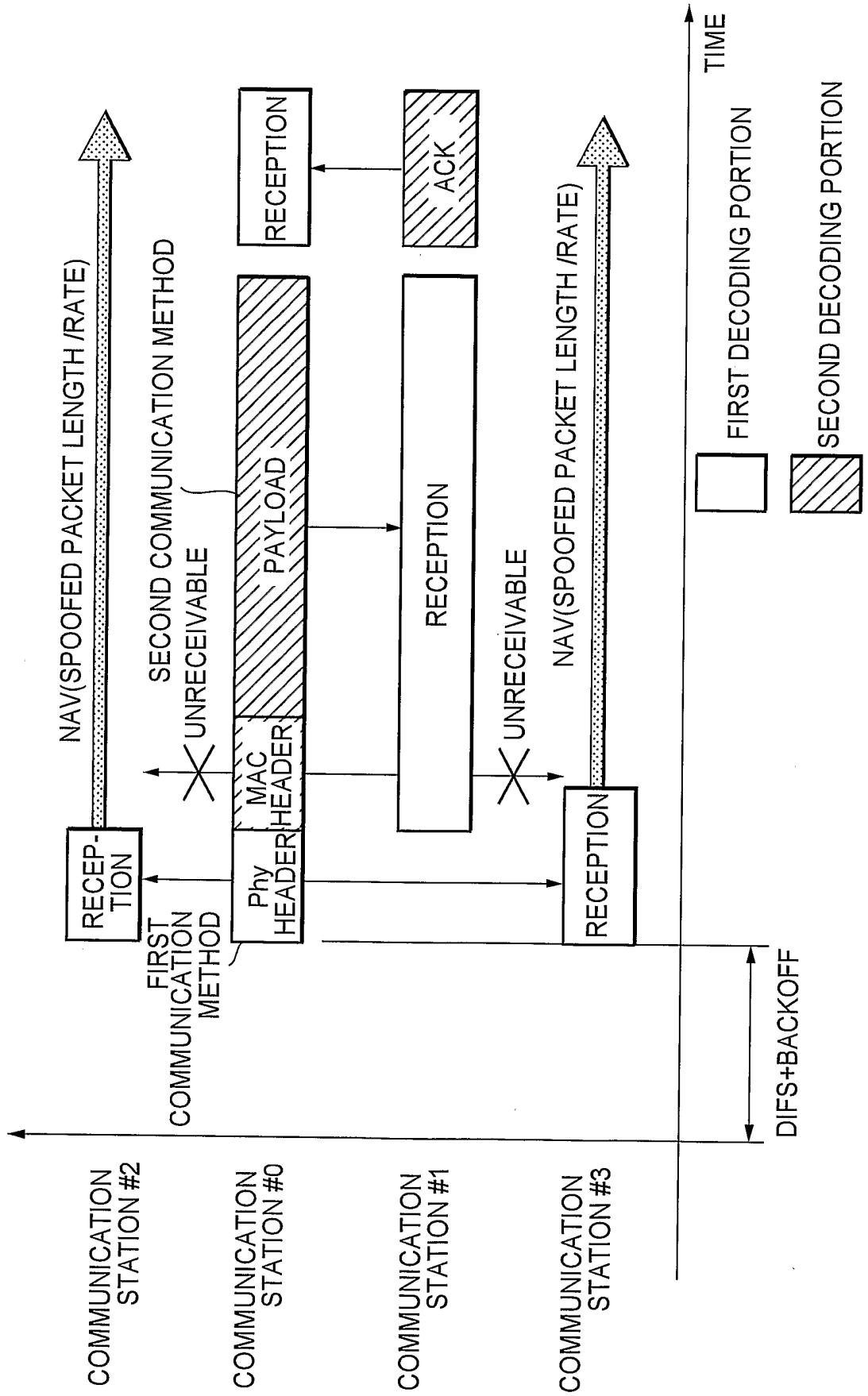

FIG. 8



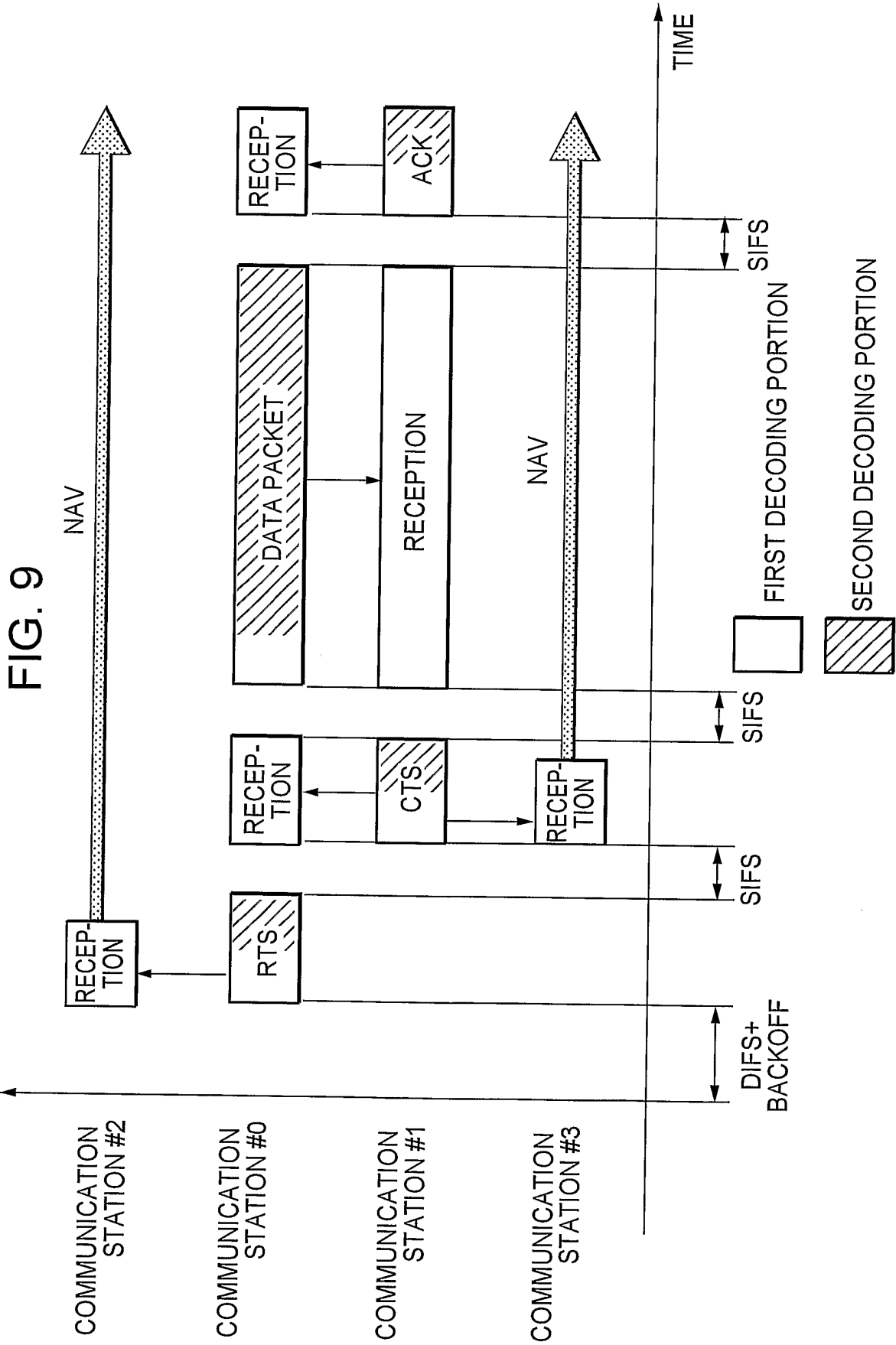

FIG. 10

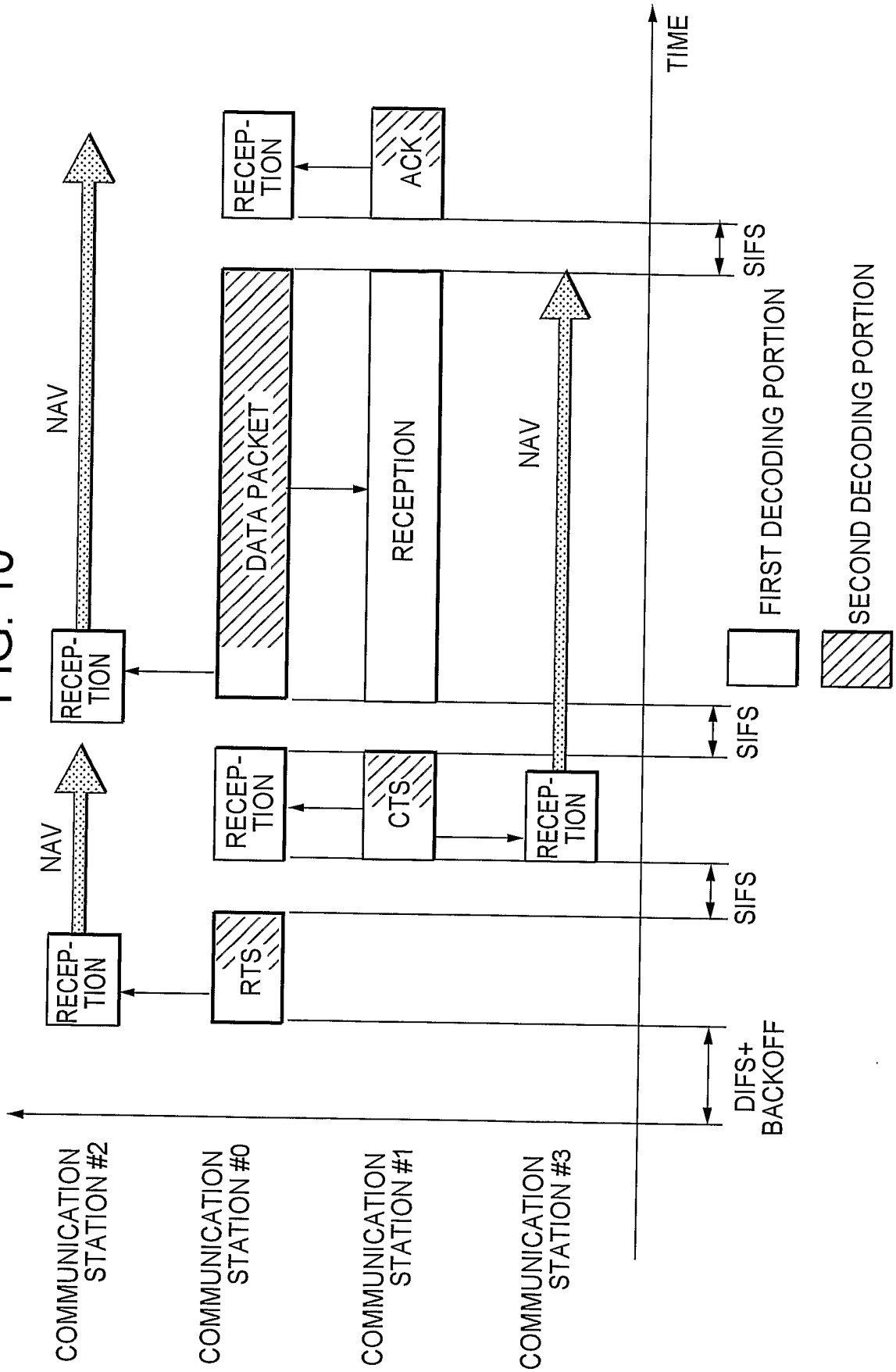

FIG. 11

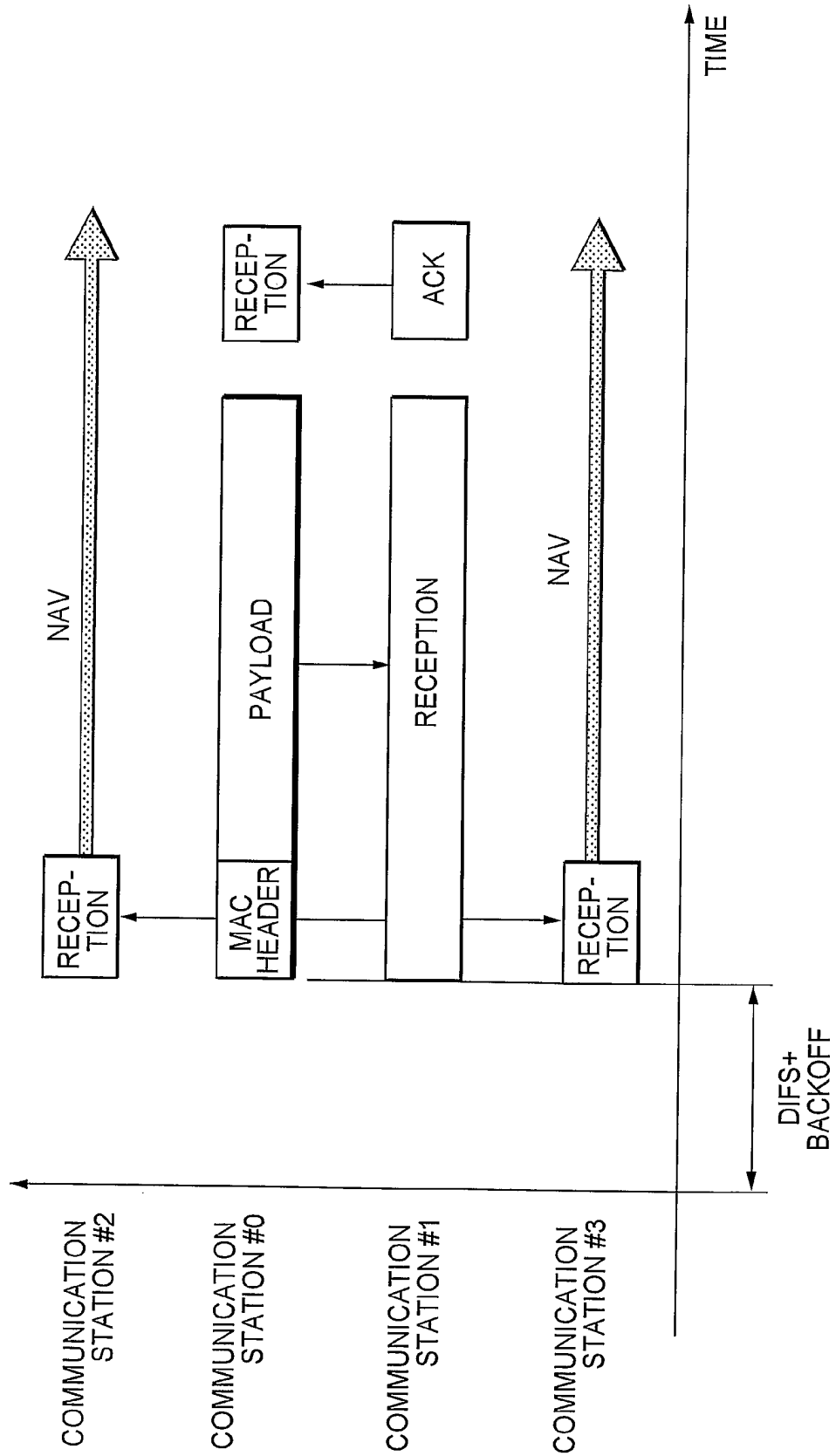

FIG. 12

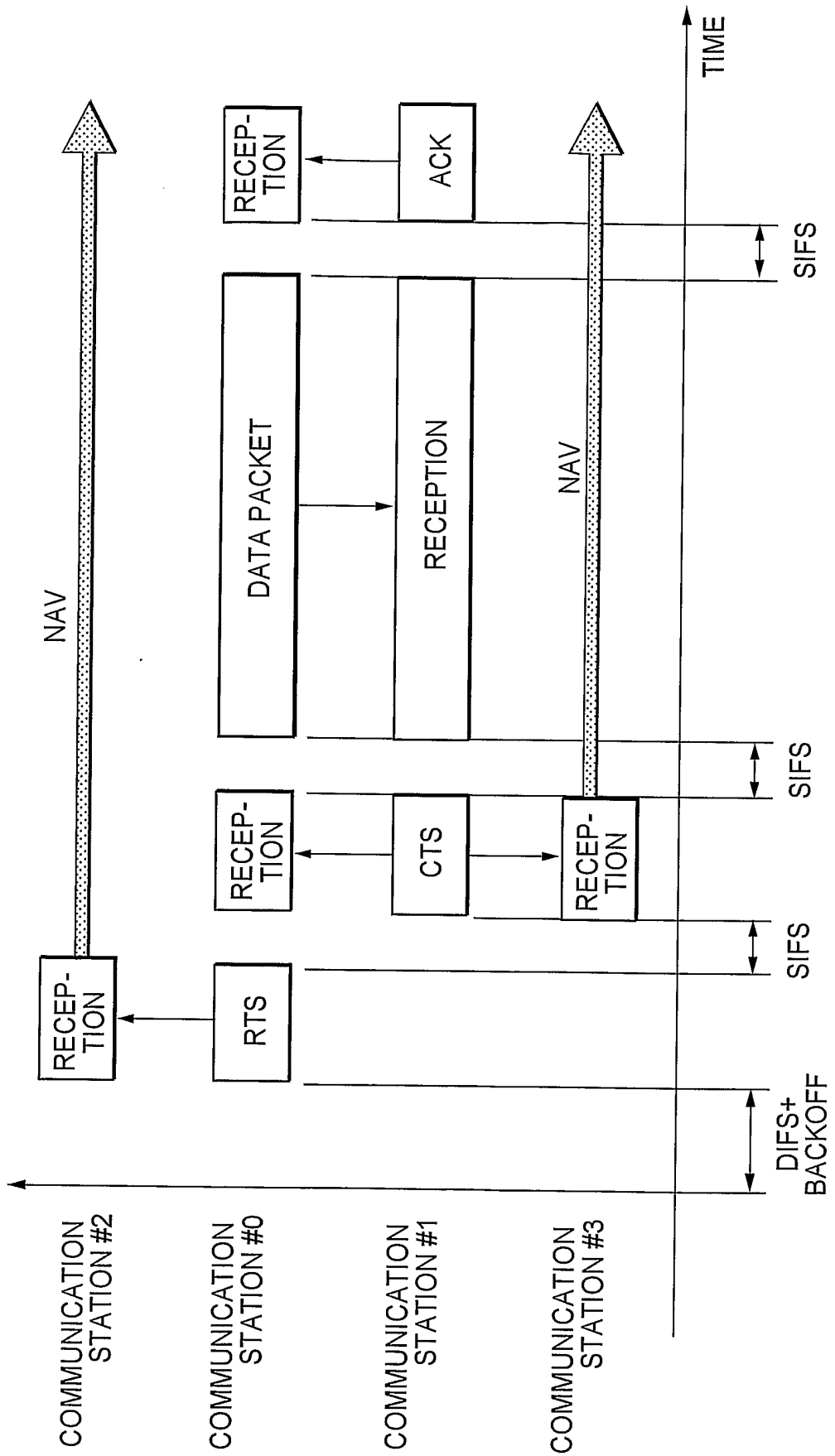

FIG. 13

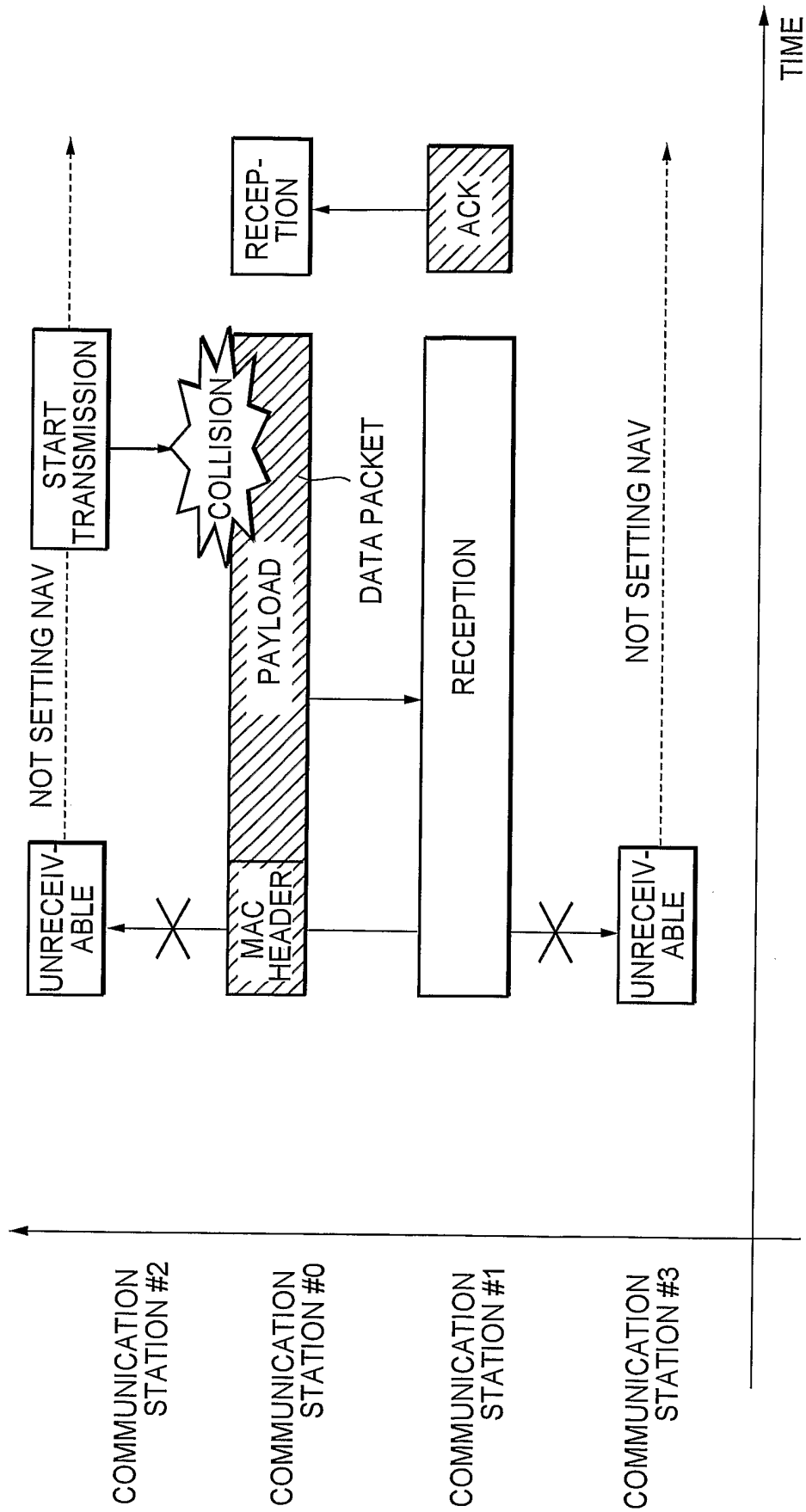

FIG. 14

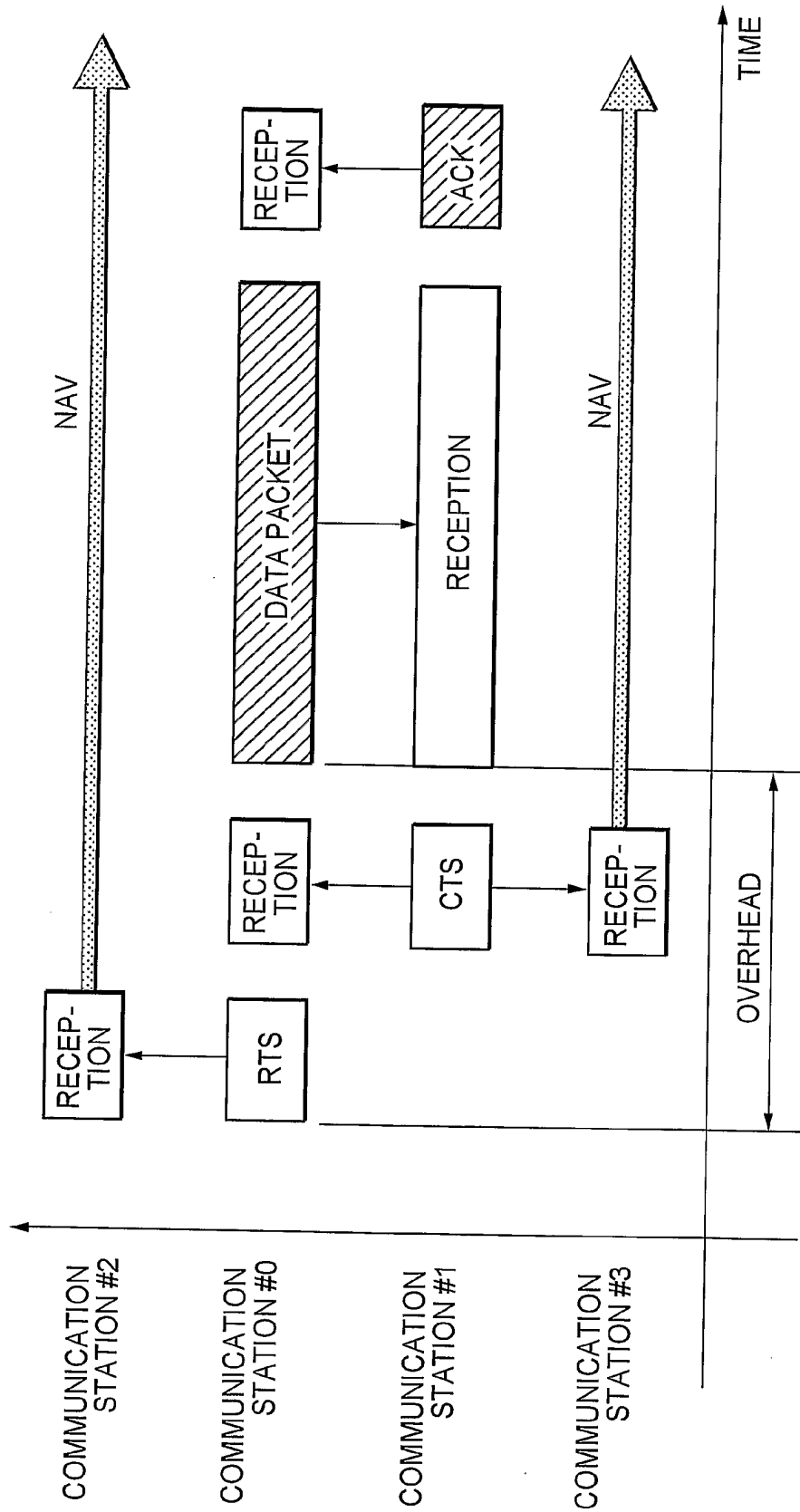

FIG. 15

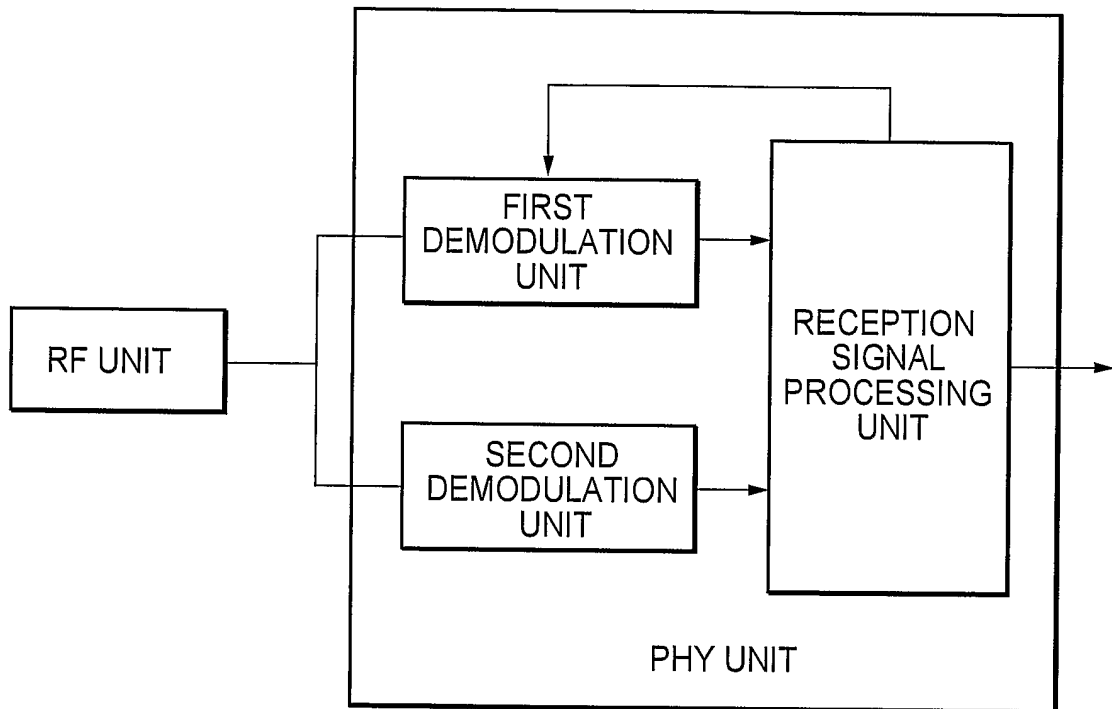

FIG. 16

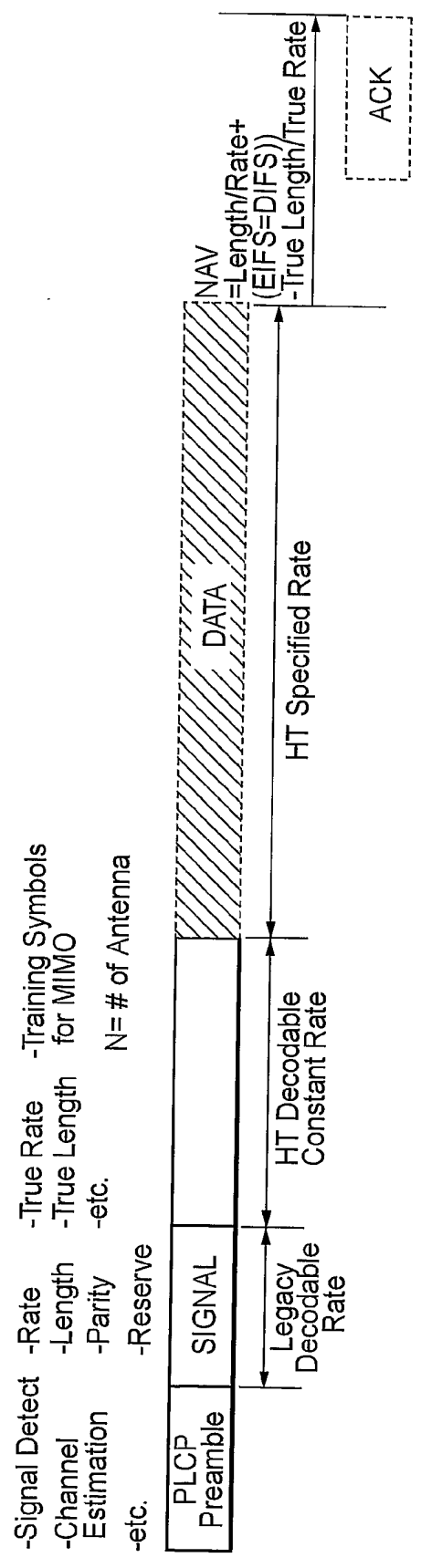
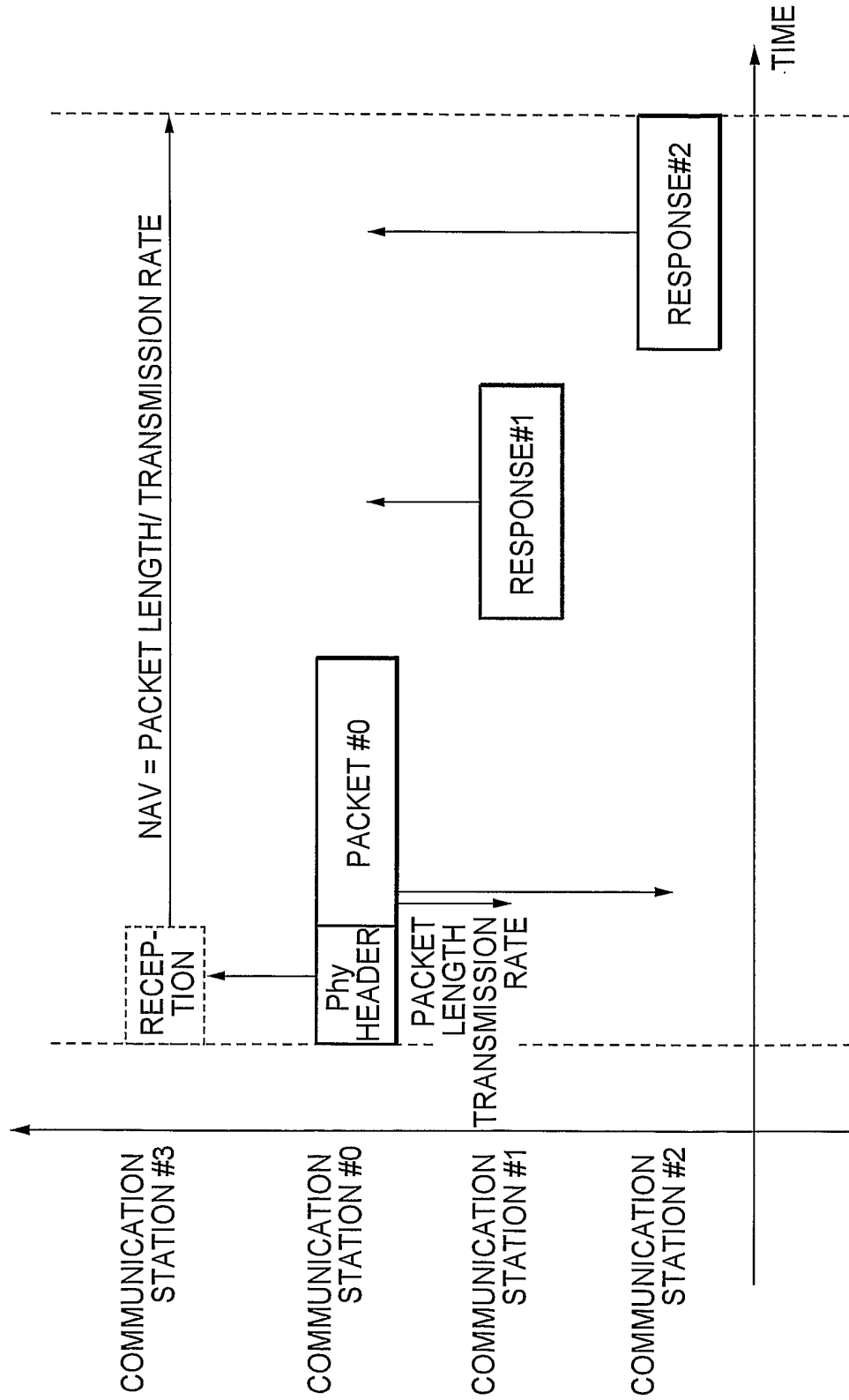

FIG. 17



INTERNATIONAL SEARCH REPORT

International Application No

PCT/JP2004/017437

C.(Continuation) DOCUMENTS CONSIDERED TO BE RELEVANT		
Category °	Citation of document, with indication, where appropriate, of the relevant passages	Relevant to claim No.
X	"Draft to standard Part 11: Wireless LAN Medium Access Control (MAC) and Physical Layer (PHY) specifications Amendment 4: Further Higher Data Rate Extension in the 2.4 GHz Band, IEEE Std 802.11g,P802.11g, D8.2," P802.11G/D8.2, XX, XX, April 2003 (2003-04), pages 1-69, XP002302840 paragraphs 19.3.2.1 - 19.3.2.5	1,17,34, 51
Y	WO 03/077457 A (AWARE, INC) 18 September 2003 (2003-09-18) paragraphs '0041!, '0073!, '0077!, '0084! - '0086!	3-9, 12-16, 20-26, 29-33, 37-43, 46-50
A	US 2003/128659 A1 (HIRSCH OLAF JOSEF ET AL) 10 July 2003 (2003-07-10) paragraphs '0004!, '0028!, '0029!, '0031!	1-51
A	US 2003/174665 A1 (BENVENISTE MATHILDE) 18 September 2003 (2003-09-18) paragraphs '0020!, '0021!, '0035!	1-51

INTERNATIONAL SEARCH REPORT

Information on patent family members

International Application No
PCT/JP2004/017437

Patent document cited in search report	Publication date	Patent family member(s)	Publication date
WO 0195579 A	13-12-2001	AU 7504601 A	17-12-2001
		CN 1432245 T	23-07-2003
		EP 1290844 A2	12-03-2003
		JP 2003536324 T	02-12-2003
		TW 511357 B	21-11-2002
		WO 0195579 A2	13-12-2001
WO 03077457 A	18-09-2003	AU 2003217994 A1	22-09-2003
		CA 2475442 A1	18-09-2003
		EP 1483857 A1	08-12-2004
		WO 03077457 A1	18-09-2003
		US 2004047296 A1	11-03-2004
US 2003128659 A1	10-07-2003	AU 2003201730 A1	24-07-2003
		EP 1466446 A1	13-10-2004
		WO 03058887 A1	17-07-2003
		AU 2003201484 A1	24-07-2003
		EP 1466445 A2	13-10-2004
		WO 03058881 A2	17-07-2003
		US 2003128684 A1	10-07-2003
US 2003174665 A1	18-09-2003	WO 03041346 A1	15-05-2003
		WO 03041428 A1	15-05-2003
		WO 03041427 A1	15-05-2003
		WO 03041343 A2	15-05-2003
		WO 03043357 A1	22-05-2003
		WO 03039054 A2	08-05-2003
		US 2003156553 A1	21-08-2003
		US 2004095911 A1	20-05-2004
		US 2003174664 A1	18-09-2003
		US 2003174690 A1	18-09-2003
		US 2003181204 A1	25-09-2003
		US 2003086437 A1	08-05-2003