

J. S. Baldwin.

Inlaying Wood.

N^o 107,150.

Patented Sept. 6, 1870.

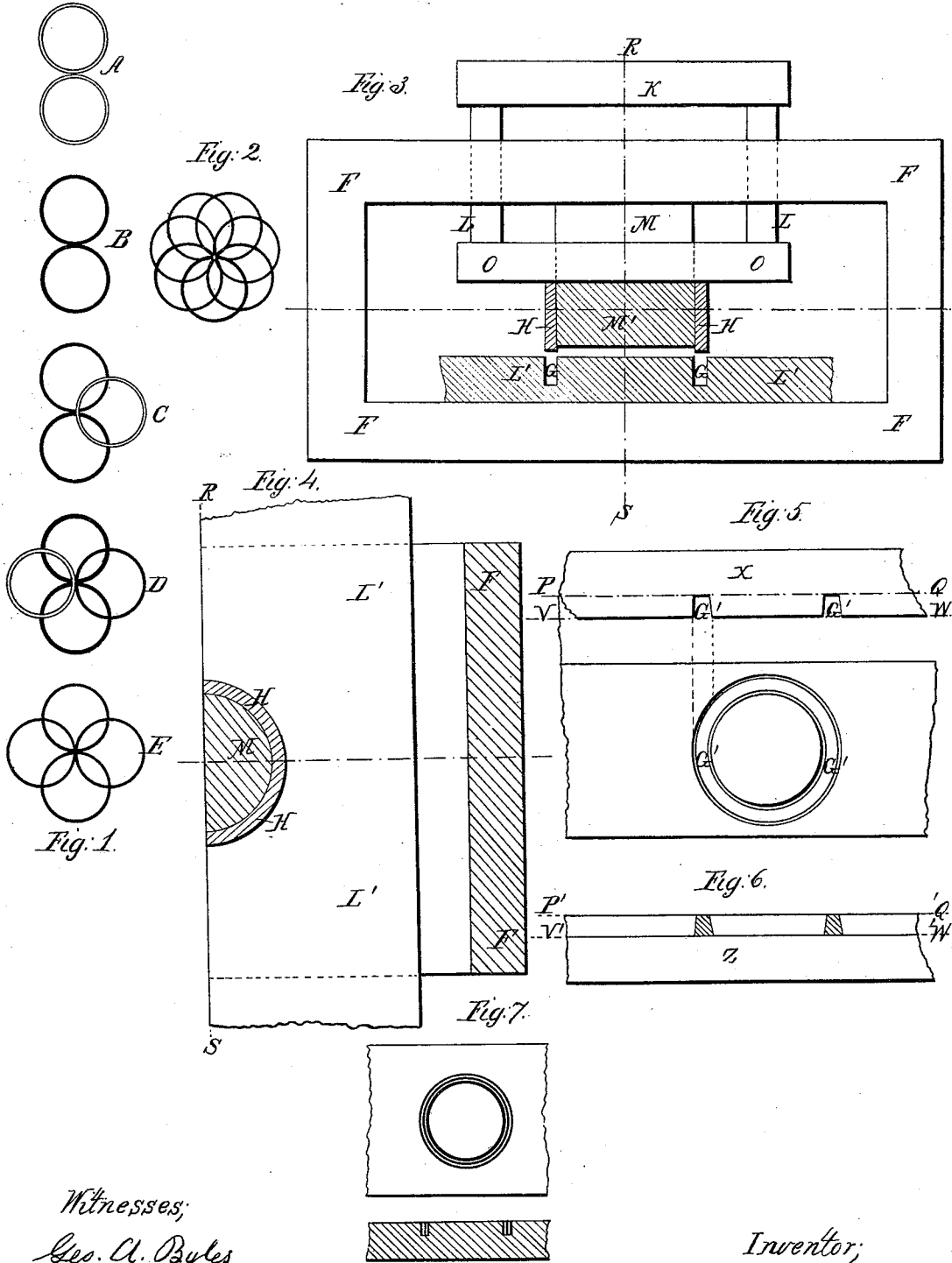

Witnesses;
 Geo. A. Byles
 C. F. Ritchel

Inventor;
 James S. Baldwin

United States Patent Office.

JAMES S. BALDWIN, OF NEWARK, NEW JERSEY, ASSIGNOR TO CHARLES F. RITCHEL, OF SAME PLACE.

Letters Patent No. 107,150, dated September 6, 1870.

METHOD OF INLAYING WOOD, &c.

The Schedule referred to in these Letters Patent and making part of the same

To all whom it may concern:

Be it known that I, JAMES S. BALDWIN, of the city of Newark, county of Essex, State of New Jersey, have invented a new and improved method of Inlaying Wood and other Materials; and I hereby declare the following to be a full and sufficient description thereof, reference being had to the annexed drawings and to the letters of reference marked thereon making a part of this specification.

In the method of inlaying heretofore practiced it has been customary to cut, in the material forming the base or foundation of the fabric, cavities of suitable shape and size, which were then filled with pieces, singly and carefully fitted to their places. This has been necessarily a tedious and laborious operation.

Another variety of work has been formed by fitting pieces to each other, the whole being cemented to and sustained by a suitable base, which does not itself appear in the pattern.

To produce the same results by my improved system, I first build up or insert a portion of the design, and then cut additional cavities in the whole fabric thus formed, fill these cavities, and continue the cutting and filling operations until the whole is completed.

In Figure 1 in the accompanying drawings—

A shows two cavities;

B, the same filled;

C, a third cavity cut through the partially formed design;

D, a fourth cavity; and

E, the completed figure, to form which, by the old method, would require the insertion of eight pieces instead of four, as in my improved method.

Figure 2 shows a rosette formed of seven pieces by my plan, in which its superiority is still more apparent, and what is true of circles is true of other forms.

Figures 3 and 4 represent in front elevation and partial section a machine for inserting the pieces in the cavities prepared for them.

For convenience of illustration, only one piece is shown undergoing the operation; but, by increasing the size and number of the several parts, any desired number of pieces can be inserted at once.

F F F F is the frame.

L' L', the piece into which the circular cavity G G is cut.

M is a mandrel securely fastened to F F F F, its lower end M being represented in section.

H H is the piece to be inserted; also,

O is a plate sliding on the mandrel M, and forcing

H H firmly and evenly to its place, by pressure on K, transmitted by the rods L L.

H is used long enough to fill several cavities, being cut off each time.

Figures 5 and 6 represent an improved method of firmly securing the inlaid pieces.

A countersunk cavity, G' G', is cut and filled, a suitable base, L, fig. 6, is firmly fastened to the back of the fabric by cement or other suitable means, V W representing the line of junction, and the portion X being now cut off by a splitting or rip-saw; on the line P Q the design is uncovered by inserting composite pieces of different colored woods, previously cemented or otherwise firmly united prior to insertion, the economy and beauty of the work are materially enhanced.

Figure 7 shows such a piece in plan and section, formed by cementing together before insertion several concentric and different-colored rings, the whole being treated like H H, figs. 3 and 4.

It will be understood that, by my improved system, not only may a complicated design be produced with fewer pieces, but in such design all the pieces cut and inlaid will be similar in size and shape, all the cavities be similar, and further, that the stock of the base or foundation slab which is inlaid will interlock with the inserted pieces, so as to induce to great strength in the whole design.

Of course, any machinery or tools deemed best may be employed to cut the cavities and insert the pieces. For cutting annular cavities and inserting cylindrical rings, the devices shown I deem well adapted to the purposes of carrying out my invention.

I am aware that designs in cutting and engraving have been produced by a series of circular or other shaped figures cut across each other, such as done in "lathe" work on watches, &c., and I am also aware of designs for inlaying having been suggested, in which a series of circles or polygons are represented interlocking each other; but in all such designs the stock is cut away entirely, and all the figures shown in the design are composed of separate pieces of stock.

What I claim as new, and desire to secure by Letters Patent, is—

Producing designs of inlaid work by cutting out the base or foundation stock and inserting a figure, and then cutting out both the stock and the inserted figure for the insertion of another figure, substantially as hereinbefore set forth and described.

JAMES S. BALDWIN.

Witnesses:

GEO. A. BYLE,
O. F. RITCHEL.