

[54] **DISPENSING SPOUT BUILT IN A CARTON BOX**

[75] Inventor: **Shinichi Araki**, Funabashi, Japan

[73] Assignee: **Lion Fat & Oil Co., Ltd.**, Tokyo, Japan

[22] Filed: **Mar. 1, 1973**

[21] Appl. No.: **337,199**

[30] **Foreign Application Priority Data**

Mar. 3, 1972 Japan..... 47-26804

[52] U.S. Cl. 229/17 R; 229/51 D; 229/51 TC

[51] Int. Cl. **B65d 5/72**

[58] Field of Search 229/17 R, 51 TS, 51 TC, 229/51 SC, 51 D

[56]

References Cited

UNITED STATES PATENTS

2,417,550	3/1947	Guyer	229/17 R
2,449,046	9/1948	Bornes	229/51 D X
3,387,763	6/1968	Koolnis	229/17 R
3,520,465	7/1970	Spiering	229/17 B

Primary Examiner—Edward J. McCarthy
Attorney, Agent, or Firm—Milton Osheroff

[57]

ABSTRACT

There is provided a dispensing spout in a carton box adapted to accommodate powdery materials like detergents which is simple in construction and easy not only to open by pushing with the finger but also to keep closed after it has been cut out.

2 Claims, 5 Drawing Figures

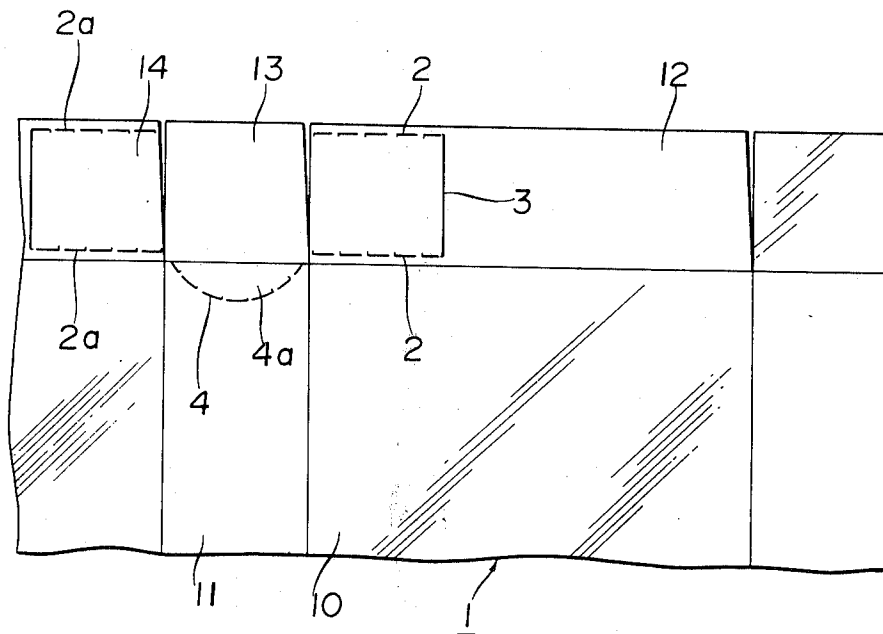

FIG. 1

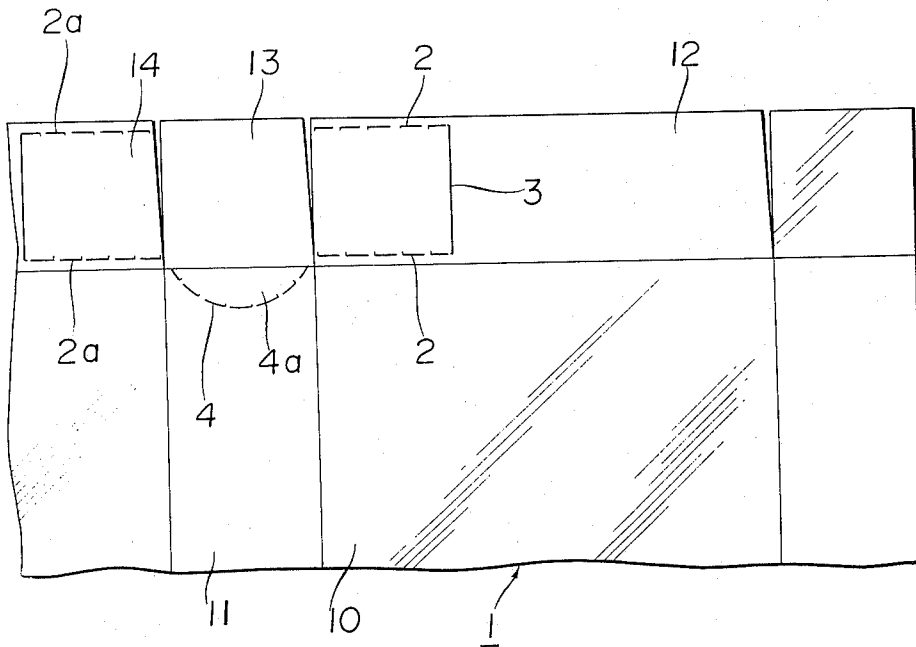

FIG. 2

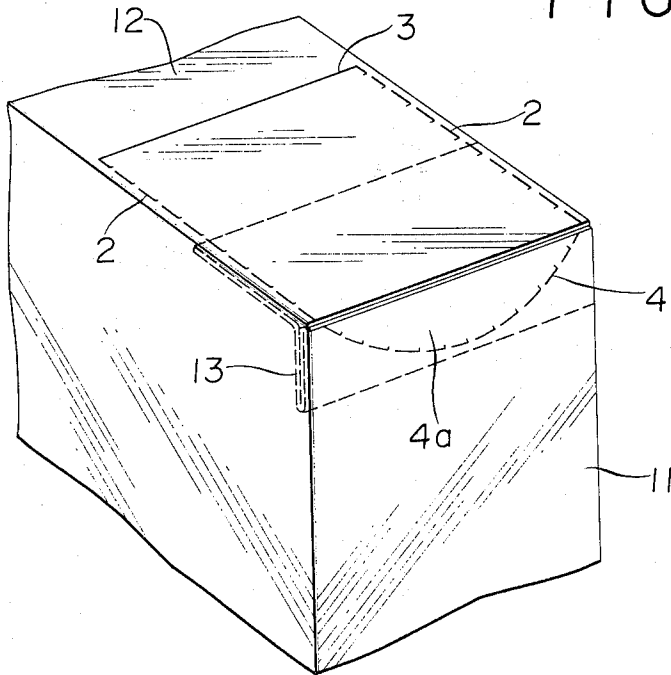

FIG. 3a

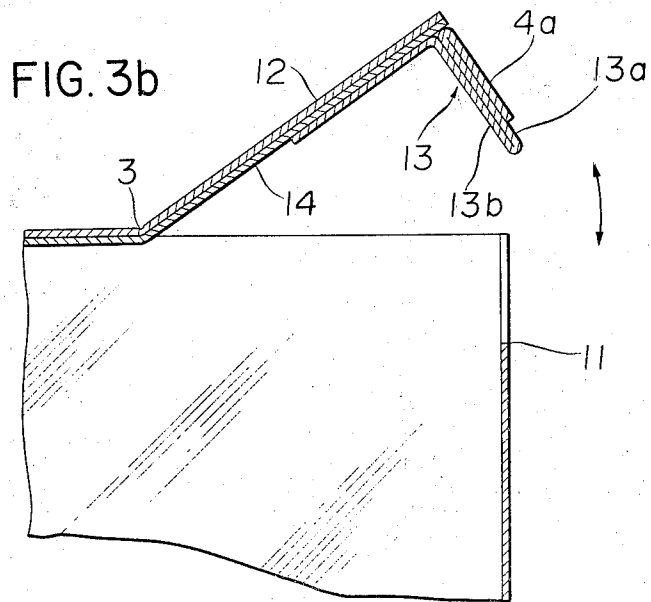
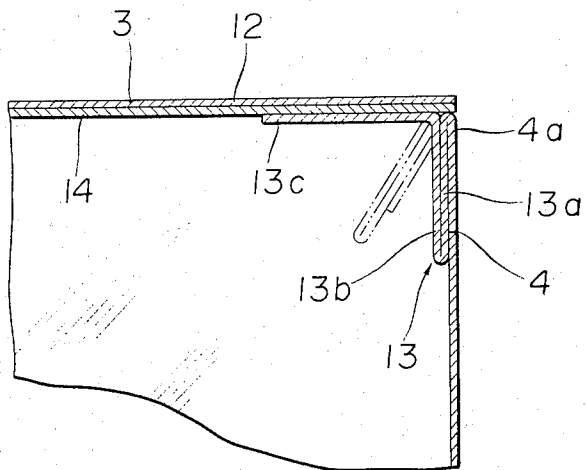
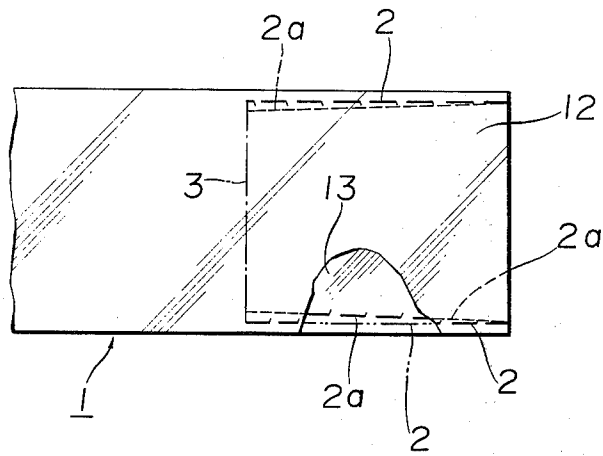

FIG. 4



DISPENSING SPOUT BUILT IN A CARTON BOX

BACKGROUND OF THE INVENTION

This invention relates to a dispensing spout built in a carton box, and more particularly to a dispensing spout in a carton box used as a detergent container or the like which can easily be cut out to open with the finger in a simple way.

Conventional carton boxes for accommodating detergents or the like have the disadvantages that it is necessary to seal the dispensing spouts so as to prevent the contents therein from being moistened once they have been opened by cutting out and that if the spout portions are perforated so deeply as to be easily cut off by pushing, there is a possibility of the perforated portions getting broken by shock. On the contrary, dispensing spouts defined by shallowly perforated lines to prevent the above-mentioned shortcoming are very hard to cut out by pushing with the finger, often hurting women's finger nails which have calisthenically been let grow long, since such shallowly perforated spouts require rather a strong pushing force to open. Further, most of the conventional dispensing spouts, once cut out, have been made to be left open as they are, thus resulting in the several disadvantages that the contents near the spouts are apt to be moistened, causing coagulation or deterioration of the contents such as detergents or the like and that if one lets a box fall by mistake, the contents will easily run out.

SUMMARY OF THE INVENTION

An object of this invention is to provide a dispensing spout built in a carton box for accommodating powdery materials like detergents which is simple in construction and easy to open by pushing with the finger.

Another object of this invention is to provide a dispensing spout for a carton box which serves as an easy-to-open and close lid, thereby thoroughly being free from the disadvantages as seen in conventional dispensing spouts which are impossible to keep closed after they have been cut out; that is, moisture enters through the open spout into the contents to coagulate or deteriorate them or the contents easily run out through the open spout if one drops a box on the ground or floor by mistake.

BRIEF DESCRIPTION OF THE DRAWINGS

The accompanying drawings show a preferred embodiment of this invention, in which:

FIG. 1 is an unfolded view of a carton box formed with a dispensing spout according to this invention.

FIG. 2 is a perspective view showing the box of FIG. 1 in a completed state, and

FIG. 3a and FIG. 3b are sectional views showing the portions of the folding flap of the dispensing spout under opened and closed conditions respectively.

FIG. 4 is a fragmentary top elevation of the box of FIG. 2, partly broken away.

DETAILED DESCRIPTION OF THE INVENTION

First referring to FIG. 1, from a side wall 10 of a carton box as a whole indicated by 1 extends a rectangular upper flap 12 which is to form the top surface of the completed carton box. From either of the shorter sides of the upper flap 12 continuously extend two perforated break lines 2 of a given length parallel with each

other and terminating in appropriate places according to the required size of the spout, and between the two points on the surface of said upper flap 12 in which the break lines 2 terminate respectively there is a compressed score line 3 parallel with the shorter sides of the upper flap 12.

14 is a lower flap which is to be laid under the upper flap 12 when the box is completed, and also on this lower flap 14 are formed continuous break lines 2a in the same manner as the break lines 2. However, these break lines 2a are positioned so as to be slightly out of alignment with the break lines 2 outwardly or inwardly with respect to the longer sides of the flap 12 or transversely when overlapped with each other, thus preventing moisture from penetrating into the interior of the box through the supposed gaps of the overlapped break lines.

Another compressed score line is formed on the surface of the lower flap 14 in the same manner as the like line 3.

A deeply perforated cutting line 4 which is easy to cut is formed in a semi-circle on a rectangular side wall 11 positioned between the upper and lower flaps 12 and 14 of the carton box 1 and adjacent the side wall 10. As seen in FIG. 1, this cutting line 4 extends from a point on the top edge of the side wall 11 and terminates in another different point on the same top edge. The break lines 2 and 2a on the upper and lower flaps 12 and 14 are overlapped with each other so as to have their extending points on the side edges of the flaps 12 and 14 correspond to the extending and terminating points of the cutting line 4, thus facilitating opening of the dispensing spout by pushing with the finger. Above this cutting line 4 a folding flap 13 is provided adjacent the side wall 11, integral therewith, and extending between the upper and lower flaps 12 and 14, which comprises three folded portions; i.e., a first portion 13a having a length a little greater than the width between the middle point of the semi-circular cutting line 4 and the top edge of the side wall 11 so as to have its tip disposed below said middle point when the flap 13 is folded at said top edge and overlapped with the side wall 11, a second portion 13b overlapped with said first portion 13a having the same length as that of said first portion 13a, and a third portion 13c naturally having a length corresponding to the remainder of the overall length of the folding flap 13 obtained after deducting the combined length of said first and second portions 13a and 13b. This folding flap 13 is folded in such a manner as shown in FIGS. 3(a) and 3(b); it is inwardly folded along the top edge of the side wall 11 by a length a little greater than the distance between the top edge of the side wall 11 and the lowermost point of the cutting line 4, thus forming the first portion 13a, then at the tip of said first portion 13a it is reversed in a direction opposite to the folding direction of the first portion 13a by the same length therewith to form the second portion 13b, and the remainder of the folding flap 13 not folded so far is overlapped with the underside of the lower flap 14 and bonded thereto by adhesive to form the third portion 13c. During this process, bonding is made by adhesive between the first portion 13a and a semi-circular portion 4a defined by the cutting line 4 and between the first portion 13a and the second portion 13b respectively. As described above, since the length of the first portion 13a is a little greater than the distance between the top edge of the side wall 11 and the lower-

most point of the cutting line 4, the common tip of the first and second portions 13a and 13b is disposed a little below the lowermost edge of the cutting line 4 so that said tip hits against the inside of the semi-circular portion 4a when the contents in the box outwardly press against the first portion 13a in the case of the box falling down, thus preventing the contents from running out of the box.

FIG. 2 is a perspective view of the dispensing spout of the completed carton box, referring to which drawing description will be made on how to open the dispensing spout. First, push inwardly with the finger the semi-circular portion 4a defined by the large and deeply perforated cutting line 4. As a result, the semi-circular portion 4a integral by adhesive with the folding flap 13 and with the side wall 11 will be cut off and pushed into the inside of the box together with the folding flap 13, thus forming a hole which has a size large enough for a finger to enter. (Incidentally, the first portion 13a is bonded to the side wall 11 by adhesive at a small contact area other than the area between itself and the semi-circular portion 4a, but the portion 13a is easily detachable from said small contact area when pushed with finger finger.) Next, lift up the semi-circular portion 4a and the folding flap 13 together with the upper and lower flaps 12 and 14, and then the upper and lower flaps 12 and 14 and the folding flap 13 bonded together will be cut out to the score line 3 along the continuous break lines 2 and 2a, and thus the spout will be opened. This spout is able to serve as a lid as well, in the following manner; as shown in FIG. 3(b), the tip of the folded folding flap 13 comprising part of the first and second portions 13a and 13b is adapted to serve as an insertion tip to keep the lid closed with the cooperation of the semi-circular portion 4a. Thus, by virtue of the peculiar construction of the lid as above-mentioned, the contents such as detergents in the carton box are always free from the deterioration thereof to be caused by entry of moisture into the interior of the carton box.

From the foregoing, it will be noted that this invention is able to completely eliminate the aforesaid disadvantages possessed by the conventional types of dispensing spouts and provides a very convenient dispensing spout built in a carton box which is not only easily openable by pushing with the finger and but also serves as an easy-to-open and close lid once it has been opened.

Now that an embodiment of this invention has been described in detail, it will be clear that any modifications thereof will be obvious to those skilled in the art, except as they appear in the appended claims.

What is claimed is:

1. A dispensing spout built in a carton box comprising:

- a spout portion formed in a first side wall of said carton box and defined by a deeply perforated cutting line extending from a point on a top edge of said first side wall and terminating in another different point on the same edge;
- a first flap extending integrally from said top edge of said first side wall;
- second and third flaps extending integrally from top edges of second and third side walls disposed adjacent said first side wall at opposed sides thereof, and being overlapped with each other;
- said first flap having a first portion defined by inwardly folding said first flap at the top edge of said first side wall by a length a little greater than the distance between said top edge of said first side wall and the lowermost point of said cutting line, said first portion overlapping and being adhered to the reverse side of said portion of said first side wall defined by said cutting line, a second portion defined by reversely folding said first flap at the tip of said first portion in a direction opposite to the folding direction of said first portion by a length the same as that of said first portion, said second portion overlapping and being adhered to said first portion, and a third portion extending from said second portion, said third portion being folded into overlapping relation with, and adhered to, said overlapped first and second flaps.

2. The dispensing spout as claimed in claim 1, further comprising:

- two continuous break lines of a given length formed on each said second and third flaps, extending parallel with each other from side edges of the second and third flaps facing said first flap, said break lines being overlapped slightly transversely out of alignment with each other, but with extending points thereof on said side edges positionally corresponding to extending and terminating points of said cutting line on said top edge of the first side wall respectively.

* * * * *

50

55

60

65