

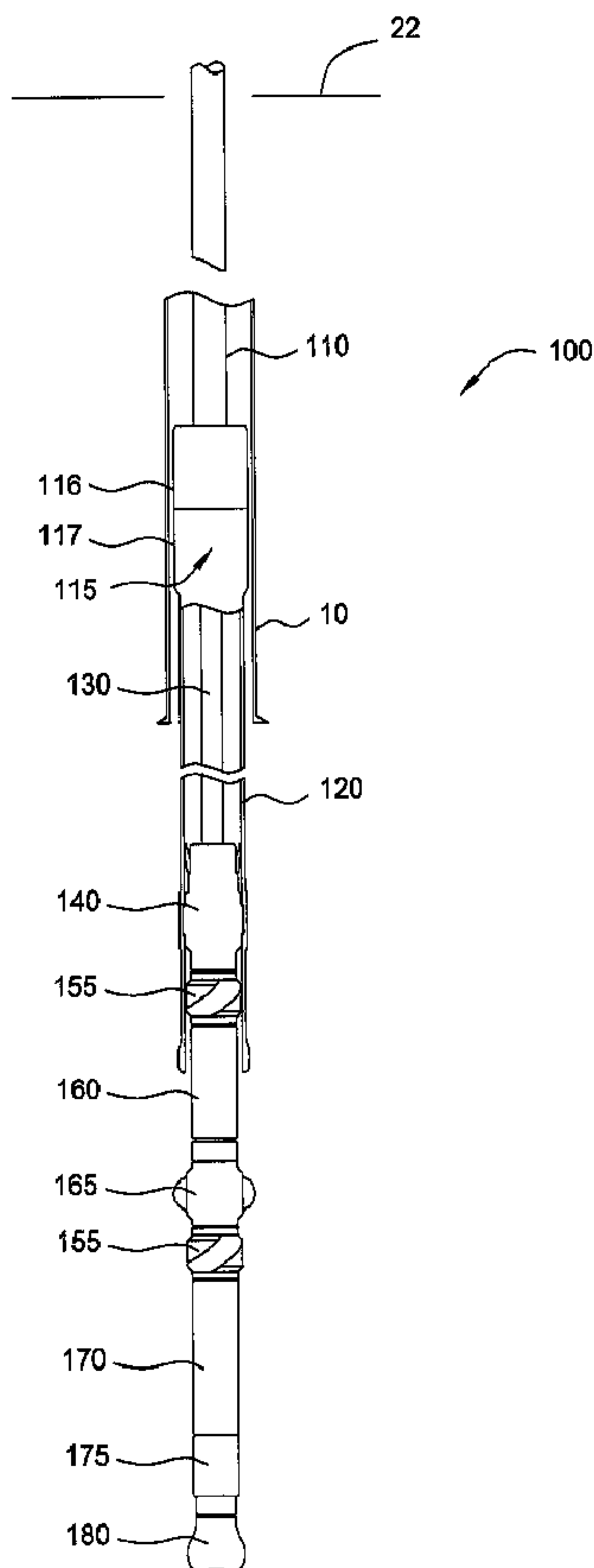

(22) Date de dépôt/Filing Date: 2007/05/22
 (41) Mise à la disp. pub./Open to Public Insp.: 2007/11/22
 (45) Date de délivrance/Issue Date: 2013/07/09
 (30) Priorité/Priority: 2006/05/22 (US60/747,929)

(51) Cl.Int./Int.Cl. *E21B 7/20* (2006.01),
E21B 23/04 (2006.01), *E21B 23/06* (2006.01),
E21B 33/13 (2006.01), *E21B 7/04* (2006.01)
 (72) Inventeurs/Inventors:
 GIROUX, RICHARD L., US;
 ODELL, ALBERT C., II, US;
 XU, WEI, US
 (73) Propriétaire/Owner:
 WEATHERFORD/LAMB, INC., US
 (74) Agent: MBM INTELLECTUAL PROPERTY LAW LLP

(54) Titre : METHODES ET APPAREILLAGE DE FORAGE AVEC CHEMISE
 (54) Title: METHODS AND APPARATUS FOR DRILLING WITH CASING



(57) Abrégé/Abstract:

In one embodiment, a method of forming a wellbore includes running a liner drilling assembly into the wellbore, the liner drilling assembly having a liner, a conveying member, one or more connection members, and a drilling member. The method includes



(57) **Abrégé(suite)/Abstract(continued):**

temporarily suspending the liner at a location below the rig floor; releasing the conveying member and the drilling member from the liner; re-connecting the conveying member to the liner; releasing the liner from its location of temporary suspension; and advancing the liner drilling assembly.

ABSTRACT OF THE DISCLOSURE

In one embodiment, a method of forming a wellbore includes running a liner drilling assembly into the wellbore, the liner drilling assembly having a liner, a conveying member, one or more connection members, and a drilling member. The method includes temporarily suspending the liner at a location below the rig floor; releasing the conveying member and the drilling member from the liner; re-connecting the conveying member to the liner; releasing the liner from its location of temporary suspension; and advancing the liner drilling assembly.

METHODS AND APPARATUS FOR DRILLING WITH CASING

BACKGROUND OF THE INVENTION

Field of the Invention

[0002] The present invention relates apparatus and methods for drilling and completing a wellbore. Particularly, the present invention relates to apparatus and methods for forming a wellbore, lining a wellbore, and circulating fluids in the wellbore. The present invention also relates to apparatus and methods for cementing a wellbore.

Description of the Related Art

[0003] In the drilling of oil and gas wells, a wellbore is formed using a drill bit that is urged downwardly at a lower end of a drill string. After drilling a predetermined depth, the drill string and bit are removed, and the wellbore is lined with a string of casing. An annular area is thus defined between the outside of the casing and the earth formation. This annular area is filled with cement to permanently set the casing in the wellbore and to facilitate the isolation of production zones and fluids at different depths within the wellbore.

[0004] It is common to employ more than one string of casing in a wellbore. In this respect, a first string of casing is set in the wellbore when the well is drilled to a first designated depth. The well is then drilled to a second designated depth and thereafter lined with a string of casing with a smaller diameter than the first string of casing. This process is repeated until the desired well depth is obtained, each

WEAT/0760

additional string of casing resulting in a smaller diameter than the one above it. The reduction in the diameter reduces the cross-sectional area in which circulating fluid may travel. Also, the smaller casing at the bottom of the hole may limit the hydrocarbon production rate. Thus, oil companies are trying to maximize the diameter of casing at the desired depth in order to maximize hydrocarbon production. To this end, the clearance between subsequent casing strings having been trending smaller because larger subsequent casings are used to maximize production.

[0005] Drilling with casing or liner is a method of forming a borehole with a drill bit attached to the same string of tubulars that will line the borehole. In other words, rather than run a drill bit on smaller diameter drill string, the bit is run at the end of larger diameter tubing or casing or liner that will remain in the wellbore and be cemented therein. The advantages of drilling with casing are obvious. Because the same string of tubulars transports the bit and lines the borehole, no separate trip out of or into the wellbore is necessary between the forming of the borehole and the lining of the borehole. Drilling with casing or liner is especially useful in certain situations where an operator wants to drill and line a borehole as quickly as possible to minimize the time the borehole remains unlined and subject to collapse or the effects of pressure anomalies, and mechanical instability.

[0006] In the drilling of offshore wells or deep wells, the length of casing or liner may be shorter than the water depth. Also, in some instances, the wellbore may be formed in stages, such as installing casing and thereafter hanging a liner from the casing. In both cases, the length of casing may not extend back to surface.

[0007] There is a need, therefore, for running a length of drill casing or liner into the hole to form the wellbore.

SUMMARY OF THE INVENTION

[0008] In one embodiment, a drilling apparatus includes a liner as a portion of the drill string. The axial and torsional loads are carried by the drill pipe and then

WEAT/0760

transferred to the drilling liner by the use of a liner drilling tool. The forces are then transmitted along the liner to a latch. The loads are then transferred from the liner to the latch and attached BHA. The drilling apparatus may include an inner string that connects the liner drilling tool at the liner top to the BHA. This way, when the liner drilling tool and latch are disconnected from the liner, the drill pipe can pull the inner string and BHA from the liner and bore hole. In one embodiment, releasing and pulling the liner drilling tool also releases and pulls the BHA out of hole with the inner string. The inner string can also act as a conduit for fluid flow from the drillpipe to the BHA below. It should be noted that the fluid flow could be split between the inner string and the liner ID, or diverted so the entire flow is in the annulus between the inner string and the liner ID.

[0009] In another embodiment, a method of forming a wellbore includes running a liner into the wellbore; suspending the liner at a location below the rig floor; running a drilling bottom hole assembly through the liner on a drill string; attaching the drill string to the liner; releasing the liner from its location of suspension; and advancing the liner through the wellbore on the drill string.

[0010] The present invention relates methods and apparatus for lining a wellbore. In one embodiment, a method of forming a wellbore includes running liner drilling assembly into the wellbore, the liner drilling assembly including a liner, a conveying member, one or more connection members, and a drilling member. The method includes temporarily suspending the liner at a location below the rig floor; releasing the conveying member and the drilling member from the liner; re-connecting the conveying member to the liner; releasing the liner from its location of temporary suspension; and advancing the liner drilling assembly.

[0011] In another embodiment, an apparatus for forming a wellbore includes a liner coupled to a drilling member; a conveying member releasably connected to the liner, the conveying member adapted to supply torque to the liner; a first releasable and re-settable connection members for coupling the conveying member to the liner; and a second connection member for coupling the liner to the drilling member.

WEAT/0760

BRIEF DESCRIPTION OF THE DRAWINGS

[0012] So that the manner in which the above recited features of the present invention can be understood in detail, a more particular description of the invention, briefly summarized above, may be had by reference to embodiments, some of which are illustrated in the appended drawings. It is to be noted, however, that the appended drawings illustrate only typical embodiments of this invention and are therefore not to be considered limiting of its scope, for the invention may admit to other equally effective embodiments.

[0013] Figure 1 shows an embodiment of the liner drilling system according to aspects of the present invention.

[0014] Figure 2 shows an embodiment of the liner drilling system with the liner top suspended from a blow-out prevent ram.

[0015] Figure 3 shows another embodiment of a liner drilling assembly.

[0016] Figures 4-8 shows the liner drilling assembly of Figure 3 in operation.

[0017] Figure 9 shows another embodiment of a liner drilling assembly.

DETAILED DESCRIPTION OF THE PREFERRED EMBODIMENT

[0018] In one embodiment, a drilling apparatus includes a liner as a portion of the drill string. The axial and torsional loads are carried by the drill pipe and then transferred to the drilling liner by the use of a liner drilling tool. The forces are then transmitted along the liner to a latch. The loads are then transferred from the liner to the latch and attached BHA. The drilling apparatus may include an inner string that connects the liner drilling tool at the liner top to the BHA. This way, when the liner drilling tool and latch are disconnected from the liner, the drill pipe can pull the inner string and BHA from the liner and bore hole. In one embodiment, releasing and pulling the liner drilling tool also releases and pulls the BHA out of hole with the inner

WEAT/0760

string. The inner string can also act as a conduit for fluid flow from the drill pipe to the BHA below. It should be noted that the fluid flow could be split between the inner string and the liner ID, or the fluid flow can be fully diverted to the annulus area between the inner string OD and the liner ID. In one embodiment, the fluid returning to the surface may flow through the annular area between the wellbore and the outer diameter of the liner and/or the annular area between the inner diameter of the liner and the outer diameter of the inner string.

[0019] Figure 1 shows an embodiment of a drilling with liner assembly of the present invention. As shown, the drilling liner assembly 100 extends below a previously installed casing 10. The drilling liner assembly 100 is run in on drill pipe 110 from the rig floor 22. A liner drilling tool 116 is used to connect the drill pipe 110 to the liner 120. The liner drilling tool 116 may be a component of the liner top assembly 115, which may also include a liner hanger 117 and a polished bore receptacle ("PBR"). In one embodiment, the liner drilling tool 116 functions as a running tool for connecting the drill pipe 110 to the liner 120. The running tool may include a latch and/or gripping members that may releasably attach and detach from the liner 120. The running/drilling tool is adapted to transmit axial and torsional forces from the drill pipe 110 to the liner 120. The running tool may be released from the liner 120 so that the BHA may be retrieved. Preferably, the running tool has torque capability that equals or exceeds the drill pipe capability and is adapted to endure typical bore hole drilling dynamics. Exemplary running tools are disclosed in U.S. Patent No. 5,613,567, 5,531,273, and 6,032,734.

The liner top equipment (liner hanger and PBR) may also include large radial clearance for cuttings bypass and reduced equivalent circulating density ("ECD") and setting of liner hanger does not reduce the annular clearance area significantly. In one embodiment, setting of the liner hanger and release of drilling tool may be independent of the differential pressure between the inside of the tool and the outside of the liner to prevent premature activation. In another embodiment, the liner top assembly is not equipped with a packer. In yet another embodiment, the liner top assembly utilizes an expandable liner hanger.

[0020] An inner string 130 extends from the liner running/drilling tool 116 to a drilling latch 140 below. The inner string 130 may be used to convey fluid from the drill pipe 110 and/or to retrieve the BHA. Also, it should be noted that fluid may be conveyed outside of the inner string, inside of the inner string, or the flow split between both. The drilling latch 140 is adapted to releasably connect to the liner 120. An exemplary drilling latch is disclosed in U.S. Patent Application Publication No. 2004-0216892, filed on March 5, 2004 by *Giroux et al.* having serial no. 10/795214, entitled Drilling With Casing Latch.

The drilling latch 140 is adapted to transfer axial and torsional forces from the liner 120 to the bottom hole assembly ("BHA"). The drilling latch 140 may be hydraulically, mechanically, or remotely actuated. Suitable actuating mechanism includes mud pulse technology, wire line, and fiber optics.

[0021] As shown in Figure 1, the bottom hole assembly includes one or more stabilizers 155, a motor 160, an under-reamer 165, MWD/LWD 170, rotary steerable systems 175, and a drill bit 180. It must be noted that the BHA may include other components, in addition to or in place of the above items, such as other geophysical measurement sensors, stabilizers such as eccentric or adjustable stabilizers, steerable systems such as bent motor housing, other drill bits such as expandable bit or bits having nozzles or jetting orifices for directional drilling, or any other suitable component as is known to a person of ordinary skill in the art. Further, the components of the BHA may be arranged in any suitable order as is known to a person of ordinary skill in the art. For example, the under-reamer may be placed below the motor and MWD/LWD tool.

[0022] In operation, the liner drilling tool 116 and the drilling latch 140 are actuated to engage the liner 120. The liner drilling assembly 100 is then run-in to the hole using drill pipe 110. The liner drilling assembly 100 is directionally steered to drill the hole. In this respect, the hole may be drilled and lined in the same trip. The directional steering is performed using the rotary steerable system 175. The axial

WEAT/0760

and torsional forces are transferred from the drilling pipe 110 to the liner 120 through the liner running tool 116 and are then transferred from the liner 120 to the BHA through the drilling latch 140. In this respect, the inner string 130 experiences little, if any, torque that is transmitted. The inner diameter of the hole may be enlarged using the under-reamer 165. The liner drilling assembly 100 is advanced until total depth is reached. One advantage of the liner drilling assembly is that the liner protects the drilled hole during drilling. After reaching total depth, the liner hanger 117 is set to connect the liner 120 to the previously set casing. Then, the liner running tool 116 and the drilling latch 140 are released to detach from the liner 120 and are removed from the wellbore, thereby removing the BHA. In one embodiment, setting of the liner hanger 117 triggers the release of the liner running tool 116. After the BHA is retrieved, a cement operation may be performed.

[0023] In one embodiment, a cement retainer valve is tripped in and installed in the liner to enable cementing from the liner bottom. Thereafter, a conventional cementing operation may be performed. In the situation where cement cannot be circulated, a bottom squeeze may be performed. Thereafter, a second squeeze may be performed at the liner top and the liner top packer may be set in another trip into the hole.

[0024] In some circumstances, the BHA may become inoperable before total depth is reached and the BHA must be repaired or replaced. In one embodiment, the liner 120 is left in the hole and the liner drilling tool 116 and the drilling latch 140 are released. Then, the BHA is pulled out of the hole. After the BHA is repaired or replaced, the BHA is run-in to the hole and the liner drilling tool 116 and the drilling latch 140 are actuated to re-engage the liner 120. Thereafter, the drilling operation may continue by applying rotational and axial forces to the BHA. One or more BHAs may be replaced by repeating this process. It must be noted that in this embodiment, a possibility exists that the liner may become stuck during the time it takes to trip the new BHA into the hole.

WEAT/0760

[0025] In another embodiment, the liner drilling assembly 100 may be retrieved to a safe location in the wellbore. For example, the liner drilling assembly may be retrieved back to surface. The liner string 120 may then be hung on the rig floor slips. Then, the BHA may be replaced and the liner drilling assembly may be tripped back into the hole.

[0026] In another example, the liner drilling assembly 100 may be retrieved to a position inside the previously installed casing 10. In one embodiment, the liner drilling tool 100 may be suspended just below a blow out preventer ("BOP"). Figure 2 shows an embodiment of a BOP 200 for suspending a liner drilling assembly in a wellbore. As shown, a liner retaining BOP ram 210 is coupled to a BOP stack having a pipe ram BOP 215 and an annular BOP 220. It must be noted that the liner retaining BOP ram 210 may be integrated with or an attachment to the BOP stack. The liner top assembly 115 may include a profile 230 for engaging with the ram of the liner retaining BOP 210. The ram may be hydraulic actuated to move radially into engagement with the profile 230. Alternately, the liner top 115 may include a hanging shoulder adapted to rest on liner retaining BOP ram. The liner top 115 may be retained using a combination of a profile and/or hanging shoulder. The pipe ram BOP 215 and the annular BOP 220 are then used to close around drill pipe 110 during well control situations. In this respect, the hydraulic forces from the BOP ram are used to park the liner 120 in the wellbore. In one embodiment, one or more sensors may be used to position the liner top assembly 115 relative to the liner retaining BOP ram 210. An exemplary sensor includes a magnet. The magnet may be positioned on the liner hanger and a sensor may be mounted on the BOP ram 210 to determine the position of the magnet and thereby, the location of the liner hanger (e.g., the profile 230). It is contemplated that other suitable sensors such as RFID sensors known to a person of ordinary skill in the art may be used.

[0027] In operation, the liner drilling assembly 100 is retrieved sufficiently so that the liner top 115 is adjacent the liner retaining BOP 210. Then, hydraulic forces are applied to radially move the ram into engagement with the liner top, either by way of

WEAT/0760

the profile, the hanging shoulder, or both. Once parked, the liner drilling tool 116 and the drilling latch 140 are released and the BHA is pulled out of the hole. After the BHA is repaired, the BHA is run-in and the liner drilling tool 116 and the drilling latch 140 are actuated to re-engage the liner 120. Thereafter, the ram is retracted and the liner drilling assembly 100 is released for further drilling. During operation, while the liner drilling assembly is parked in the wellhead 250, the well may experience an undesired increase in pressure. To prevent a blowout, the other BOP devices (such as pipe rams, annular preventer, and/or shear rams) may be actuated to mitigate wellbore influxes.

[0028] In another embodiment, the liner retaining BOP 210 may be used to facilitate running in the liner drilling assembly. For example, the liner may be initially run-in to the liner retaining BOP 210. Thereafter, the BHA is coupled to the drilling latch, liner running tool, and the drill pipe, and is tripped into the liner. Then, the liner running tool and the drilling latch are activated to engage the liner, thereby forming the liner drilling assembly. The retaining BOP 210 is deactivated to release the liner drilling assembly to commence drilling.

[0029] In another embodiment, the liner top assembly 115 may be adapted to engage a wall of the previously installed casing 10. The casing may include a liner receiving profile formed on an interior surface of the casing. The liner receiving profile may be adapted to engage the liner hanger of the liner drilling apparatus. In operation, the liner drilling assembly is retrieved sufficiently so that the liner top is adjacent the liner receiving profile. Then, the liner hanger is actuated to engage the profile. Once parked, the liner drilling tool and the drilling latch are released, and the BHA is pulled out of the hole. After the BHA is repaired, the BHA is run-in and the liner drilling tool and the drilling latch are actuated to re-engage the liner. Thereafter, the liner hanger is retracted and the liner drilling apparatus is released for further drilling. It is contemplated that the liner receiving profile may be formed in the previously set casing 10 or the wellhead 250. Further, it is contemplated that the drilling liner assembly may be retrieved to any suitable portion of the wellbore and

WEAT/0760

suspended therein. It is further contemplated that the liner hanger may engage any portion of the casing, with or without using a liner receiving profile. In this respect, the releasable and re-settable liner hanger may be used to park/hang the liner in the previously set casing 10. The drilling liner 120 may be left in the open hole or pulled back into the set casing to prevent getting the liner stuck during the BHA replacement trip. The releasable and re-settable liner may be actuated multiple times for potentially multiple BHA trips into and out of the hole.

[0030] In another embodiment, the releasable and re-settable liner hanger may be used to facilitate run-in of the liner drilling assembly. For example, the liner equipped with a liner hanger is initially run-in to the casing. Thereafter, the liner hanger is activated to engage the casing and suspend the liner. Then, the BHA is coupled to the drilling latch, liner running tool, and the drill pipe, and is tripped into the liner. Then, the liner running tool and the drilling latch are activated to engage the liner, thereby forming the liner drilling assembly. The liner hanger is deactivated to release the liner drilling assembly to commence drilling.

[0031] In another embodiment, the liner drilling assembly may be run without using the inner string. To retrieve the BHA in the event of failure, the liner is first suspended in the wellbore using any of the above described methods of suspension. Then, a work string is lowered into the wellbore to retrieve the BHA. Exemplary work string includes drill pipe, wireline, coiled tubing, Corod (*i.e.*, continuous rod), and any suitable retrieval mechanism known to a person of ordinary skill in the art. In one embodiment, wireline is used to retrieve the BHA. After the BHA is replaced or repaired, the BHA is lowered back into the liner and the drilling latch is activated. Then, the drill pipe may be lowered and the liner drilling tool is activated to engage an upper portion of the liner. Thereafter, the liner is released from suspension to continue the drilling operation.

[0032] Figure 3 shows, another embodiment of the liner drilling assembly 300. The liner drilling assembly 300 is connected to a drill pipe 310 using a running tool 320. The running tool 320 may releasably attach the liner 305 to the drill pipe 310

WEAT/0760

and transmit axial and torsional forces. The liner drilling assembly 300 also includes a liner hanger 325 for hanging the liner 305 in a casing 301. An inner string 330 connects the running tool 320 to the casing latch 335. In one embodiment, the inner string 330 may include a pressure and volume balanced extension joint with swivel 337. The inner string 330 may stab into the latch 335 using a spear 340 which may be provided with a seal assembly. The latch 335 is adapted to releasably attach to the latch in collar 345 of the liner 305. Any suitable latch known to a person of ordinary skill in the art may be used. One or more non-rotating or rotating centralizers 350 may be used to centralize the liner 305 relative to the casing 301 or the drilled hole. The lower end of the liner 305 may include a casing shoe 355. As shown, the BHA 360 extends below the liner 305. The BHA 360 may include a motor, MWD/LWD, and rotary steerable systems. One or more under-reamer 365 and/or pilot bit 370 may be used to form the wellbore. It must be noted that the BHA 360 may include other components, in the to or in place of above listed items, such as other geophysical measurement sensors, stabilizers such as eccentric or adjustable stabilizers, steerable systems such as bent motor housing, other drill bits such as expandable bit or bits having nozzles or jetting orifices for directional drilling, or any other suitable component as is known to a person of ordinary skill in the art. Further, the components of the BHA may be arranged in any suitable order as is known to a person of ordinary skill in the art.

[0033] In operation, a sufficient length of liner 305 with the casing shoe 355 and latch in collar 345 is run so that the casing latch 335 and the BHA 360 may be installed in the liner 305. Then, the remainder of the liner 305 is run in the hole, as illustrated in Figure 4.

[0034] After running the liner 305, the liner hanger 325 is installed on top of the liner 305, as illustrated in Figure 5. The inner string 330 is run inside the liner 305 with the stab in seal assembly 340 on bottom and the pressure volume balanced slip joint 337 below the running tool 320. The running tool 320 is installed on the end of the inner string 330 and the combined tool 320/string 330 are installed in the liner hanger 325. The drilling assembly is now actuated to proceed to drill to the desired

WEAT/0760

depth. Axial and torsional forces may be transmitted from the drill pipe 310 to the liner 305 through the running tool 320 and the latch 345. In another embodiment, the inner string 330 and the running tool 320 may be connected at the surface and run into the wellbore together for connection with the liner hanger 325. In yet another embodiment, the liner hanger 325, inner string 330, and the running tool 320 may be run in as an assembled apparatus for installation on the liner 305.

[0035] After desired depth is reached, the liner hanger 325 is set. In Figure 6, it can be seen that the slips of the liner hanger 325 have been radially extended to engage the previously set casing. The setting of the liner hanger also triggers the release of the running tool 320 from the liner 305. After the latch 335 is also released the running tool 320 is pulled along with the inner string 330, casing latch 335, and BHA 360 out of the hole, as illustrated in Figure 6.

[0036] In one embodiment, the cementing operation may be performed by running a first (e.g., 16") packer such as a squeeze packer 381 into the liner 305. The packer 381 may include slips 383 to engage the interior of the liner 305. Thereafter, cement is pumped through the packer 381 to squeeze the bottom of the liner 305, as shown in Figure 7. In another embodiment, a second (e.g., 20") squeeze packer may be installed in the liner 305 and a cement squeeze is performed at the top of the liner 305. The cement from this second cement squeeze is directed to the annulus between the top of the liner 305 and the liner hanger 325, and into the formation just below the bottom of the previously run casing. In one embodiment, pressure is applied through the drill string to the top of the liner below the packer set in the ID of the previously run casing located above the liner top. This applied pressure is typically referred to as break down pressure. After establishing the break down pressure, cement is pumped in from surface, circulated down, then squeezed into the annulus between the casing hanger and the previously run casing until a suitable pressure is achieved, which is typically higher than pump in pressure (squeeze pressure). In this respect, the higher pressure provides an indication that a cement barrier has been established at the top of the liner.

[0037] In another embodiment, the cementing operation may be performed using subsurface release plugs 375, 376, as shown in Figure 8. Initially, a wireline set packer 385 having a check valve 387 is run in and is set near the bottom of the liner 305. Then, a modified running tool 390 containing subsurface release (“SSR”) type cementing plugs 375, 376 is positioned on top of the liner 305. A SSR type cementing job is the performed as is known in the art. After cementing, the packing element is set at the top of the liner hanger 325 and the modified running tool 390 is pulled out of the hole.

[0038] Figure 9 shows another embodiment of a drilling with liner assembly of the present invention. As shown, the drilling liner assembly 900 extends below a previously installed casing 10. The drilling liner assembly 900 is run in on drill pipe 910. A liner drilling tool 916 is used to connect the drill pipe 910 to the liner 920. The liner drilling tool 916 may be a component of the liner top assembly 915, which may also include a liner hanger 917 and a polished bore receptacle (“PBR”). In one embodiment, the liner drilling tool functions as a running tool for connecting the drill pipe 910 to the liner 920. The running tool may include a latch and/or gripping members that may releasably attach and detach from the liner 920. The running/drilling tool is adapted to transmit axial and torsional forces from the drill pipe 910 to the liner 920. The running tool may be released from the liner 920 so that the BHA may be retrieved. Preferably, the running tool has torque capability that equals or exceeds the drill pipe capability and is adapted to endure typical bore hole drilling dynamics. Exemplary running tools are disclosed in U.S. Patent No. 5,613,567, 5,531,273, and 6,032,734.

The liner top equipment (liner hanger and PBR) may also include large radial clearance for cuttings bypass and reduced ECD and setting of liner hanger does not reduce the annular clearance area significantly. In one embodiment, setting of the liner hanger and release of drilling tool may be independent of the differential pressure between the inside of the tool and the outside of the liner to prevent premature activation. In another embodiment, the liner top assembly is not equipped

with a packer. In yet another embodiment, the liner top assembly utilizes an expandable liner hanger and/or expandable packers.

[0039] An inner string 930 extends from the liner running/drilling tool 916 to a drilling latch 940 below. The inner string 930 may be used to convey fluid from the drill pipe 910 and/or to retrieve the BHA. Also, it should be noted that fluid may be conveyed outside of the inner string, inside of the inner string, or the flow split between both. In one embodiment, the fluid returning to the surface may flow through the annular area between the wellbore and the outer diameter of the liner and/or the annular area between the inner diameter of the liner and the outer diameter of the inner string. The drilling latch 940 is adapted to releasably connect to the liner 920. An exemplary drilling latch is disclosed in U.S. Patent Application Publication No. 2004-0216892, filed on March 5, 2004 by *Giroux et al.* having serial no. 10/795214, entitled *Drilling With Casing Latch*.

The drilling latch 940 is adapted to transfer axial and torsional forces from the liner 920 to the bottom hole assembly ("BHA"). The drilling latch 940 may be hydraulically, mechanically, or remotely actuated. Suitable actuating mechanism includes mud pulse technology, wire line, and fiber optics.

[0040] As shown in Figure 9, the bottom hole assembly includes one or more stabilizers 955, a motor 960, an under-reamer 965, MWD/LWD 970, rotary steerable systems 975, and a drill bit 980. It must be noted that the BHA may include other components, in addition to or in place of the listed items, such as other geophysical measurement sensors, stabilizers such as eccentric or adjustable stabilizers, steerable systems such as bent motor housing, other drill bits such as expandable bit or bits having nozzles or jetting orifices for directional drilling, or any other suitable component as is known to a person of ordinary skill in the art. Further, the components of the BHA may be arranged in any suitable order as is known to a person of ordinary skill in the art. For example, the under-reamer may be placed below the motor and MWD/LWD tool.

WEAT/0760

[0041] While the foregoing is directed to embodiments of the present invention, other and further embodiments of the invention may be devised without departing from the basic scope thereof, and the scope thereof is determined by the claims that follow.

THE EMBODIMENTS OF THE INVENTION FOR WHICH AN EXCLUSIVE PROPERTY OR PRIVILEGE IS CLAIMED ARE DEFINED AS FOLLOWS:

1. A method of forming a wellbore, comprising the steps of:
 - running a liner equipped with a bottom hole assembly (“BHA”) into the wellbore using a drill string;
 - extending the wellbore using the BHA and then suspending the liner in the wellbore at a location below a rig floor;
 - releasing a tubular member from the suspended liner and retrieving the drill string and the BHA to surface;
 - running the BHA on the drill string through the suspended liner;
 - attaching the drill string to the suspended liner;
 - releasing the suspended liner from the location of attachment; and
 - advancing the liner and the drill string to further extend the wellbore.
2. The method of claim 1, wherein the liner is suspended below the rig floor using a re-settable liner hanger.
3. The method of claim 1, wherein the liner is suspended below the rig floor within a housing comprising selectively actuatable rams.
4. The method of claim 1 further comprising:
 - re-suspending the liner below the rig floor;
 - detaching the drill string from the re-suspended liner; and
 - retrieving the drilling BHA to the surface.
5. The method of claim 4 further comprising:
 - running the drilling BHA on a drill string through the re-suspended liner;
 - attaching the drill string to the re-suspended liner;
 - releasing the re-suspended liner from the liner’s location of suspension;and thereafter advancing the liner through the wellbore on the drill string.

6. The method of claim 1, further comprising retrieving the tubular member to a location above the suspended liner.
7. The method of claim 6, wherein the tubular member and the drill string comprise drill pipe.
8. The method of claim 6, wherein the tubular member is the drill string.
9. The method of claim 1, further comprising repairing the BHA after retrieval and before being run in through the suspended liner.
10. The method of claim 1, further comprising replacing a drill bit of the BHA after retrieval and before being run in through the suspended liner.
11. A method of forming a wellbore comprising:
 - positioning a ram above the wellbore;
 - running a liner equipped with a drilling bottom hole assembly ("BHA") into the wellbore;
 - drilling the wellbore using the drilling BHA and then using the ram to suspend the liner;
 - retrieving the drilling BHA from the suspended liner;
 - running the drilling BHA through the liner suspended in the ram;
 - attaching the drilling BHA to the suspended liner;
 - releasing the suspended liner from the ram; and then
 - advancing the liner and the drilling BHA by drilling through the wellbore.
12. The method of claim 11 wherein the liner is run in using a conveying member selected from a group consisting of drill pipe, coiled tubing, corod, wireline, and combinations thereof.
13. The method of claim 12, further comprising:

attaching the conveying member to the liner prior to releasing the liner from the liner's location of suspension.

14. The method of claim 12, further comprising:
 - re-suspending the liner at a different location below the ram;
 - detaching the drilling BHA from the re-suspended liner; and
 - retrieving the drilling BHA to the surface.

15. The method of claim 14 further comprising:
 - running the drilling BHA through the re-suspended liner;
 - attaching the drilling BHA to the re-suspended liner;
 - releasing the re-suspended liner from the liner's location of suspension;and thereafter advancing the liner through the wellbore using the conveying member.

16. A method of forming a wellbore, comprising:
 - running a liner drilling assembly into the wellbore, the liner drilling assembly including a liner, a conveying member, one or more connection members, and a drilling member;
 - drilling the wellbore using the liner drilling assembly and then suspending the liner in the wellbore;
 - releasing the conveying member and the drilling member from the suspended liner;
 - retrieving the drilling member to the surface;
 - re-connecting the conveying member to the suspended liner;
 - releasing the liner from the liner's location of suspension; and then
 - advancing the liner and the drilling member.

17. The method of claim 16, wherein the one or more connection members include a re-settable liner drilling tool.

18. The method of claim 16, wherein the one or more connection members include a drilling latch.
19. The method of claim 16, wherein the conveying member comprises drill pipe.
20. The method of claim 16, wherein suspending the liner comprises activating a re-settable liner hanger.
21. The method of claim 16, wherein suspending the liner comprises activating a ram.
22. The method of claim 16, wherein the one or more connection members include a running tool.
23. The method of claim 16, wherein suspending the liner comprises engaging the liner to a previously set casing.
24. The method of claim 23, further comprising cementing the liner in the wellbore.
25. The method of claim 24, wherein cementing the liner comprises installing a packer in the liner.
26. The method of claim 16, further comprising an extension joint coupled to the conveying member.
27. A method of forming a wellbore, comprising the steps of:
 - a. providing a liner drilling assembly having a drilling member and a liner connected to a conveying member using one or more connection members;

- b. positioning the liner drilling assembly in the wellbore then operating the liner drilling assembly to drill the wellbore, and then attaching the liner to the wellbore;
- c. releasing the one or more connection members from the liner, thereby leaving the liner in the wellbore;
- d. retrieving the conveying member to a position above the liner;
- e. running in the conveying member to reconnect to the liner; and then
- f. drilling and advancing the liner through the wellbore.

28. The method of claim 27, wherein leaving the liner below the rig floor comprises suspending the liner below the rig floor using a selectively actuatable ram.

29. The method of claim 27, wherein the one or more connection members include a running tool.

30. The method of claim 27, further comprising engaging the liner to a previously set casing after drilling and advancing the liner to a target depth.

31. The method of claim 30, further comprising cementing the liner in the wellbore.

32. The method of claim 31, wherein cementing the liner comprises installing a packer in the liner.

33. The method of claim 30, further comprising advancing the drilling member to a target depth.

34. The method of claim 27, further comprising an extension joint coupled to the conveying member.

35. The method of claim 27, wherein leaving the liner comprises suspending the liner below the rig floor using a re-settable liner hanger.
36. The method of claim 27, further comprising cementing the liner in the wellbore.
37. A method of forming a wellbore, comprising the steps of:
drilling a wellbore while carrying a liner on a drill string; and then
attaching the liner to the wellbore at a location below a rig floor, thereby
suspending the liner in the wellbore; and then
releasing the drill string from the liner; and then
reattaching the liner to the drill string; and then
releasing the liner from the location of attachment; and then
drilling further while carrying the liner.
38. The method of claim 37, wherein the liner is attached to the location using a re-settable liner hanger.
39. The method of claim 37, wherein the liner is attached to selectively actuatable rams.
40. The method of claim 37, further comprising retrieving the drill string and repairing a BHA after retrieval and before releasing the liner from the location of attachment.
41. The method of claim 37, further comprising retrieving the drill string and replacing a drill bit after retrieval and before releasing the liner from the location of attachment.

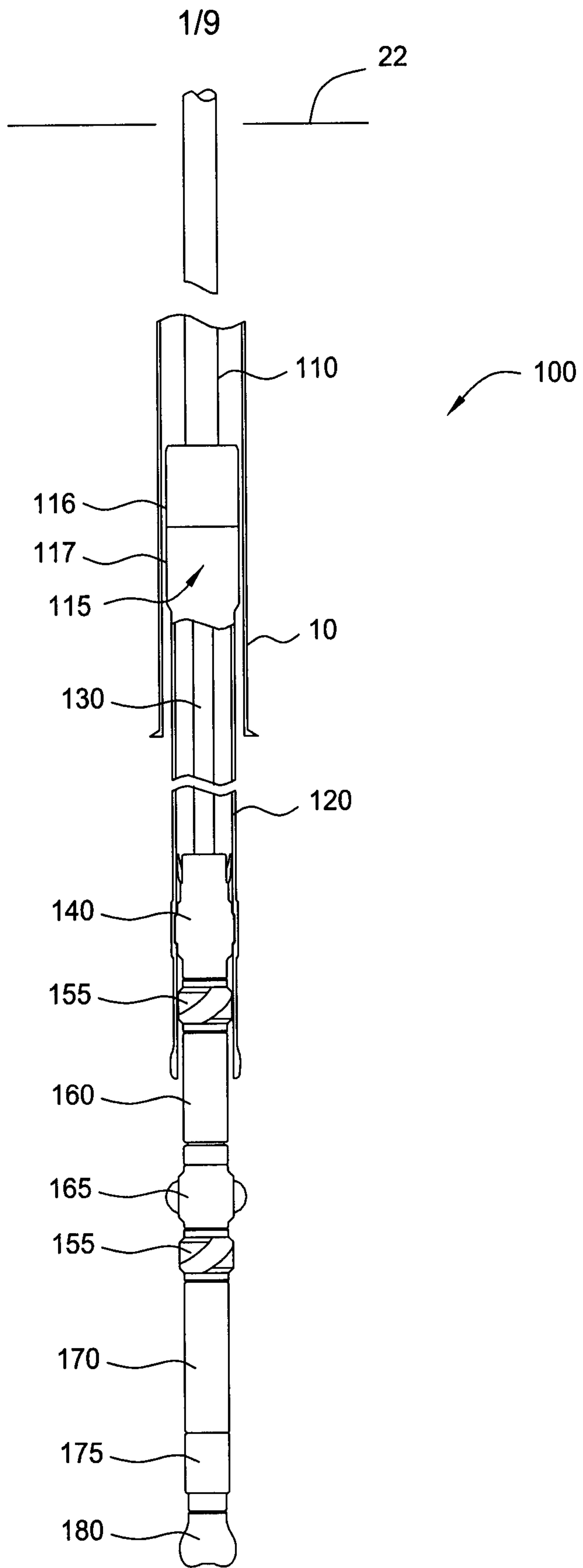

FIG. 1

2/9

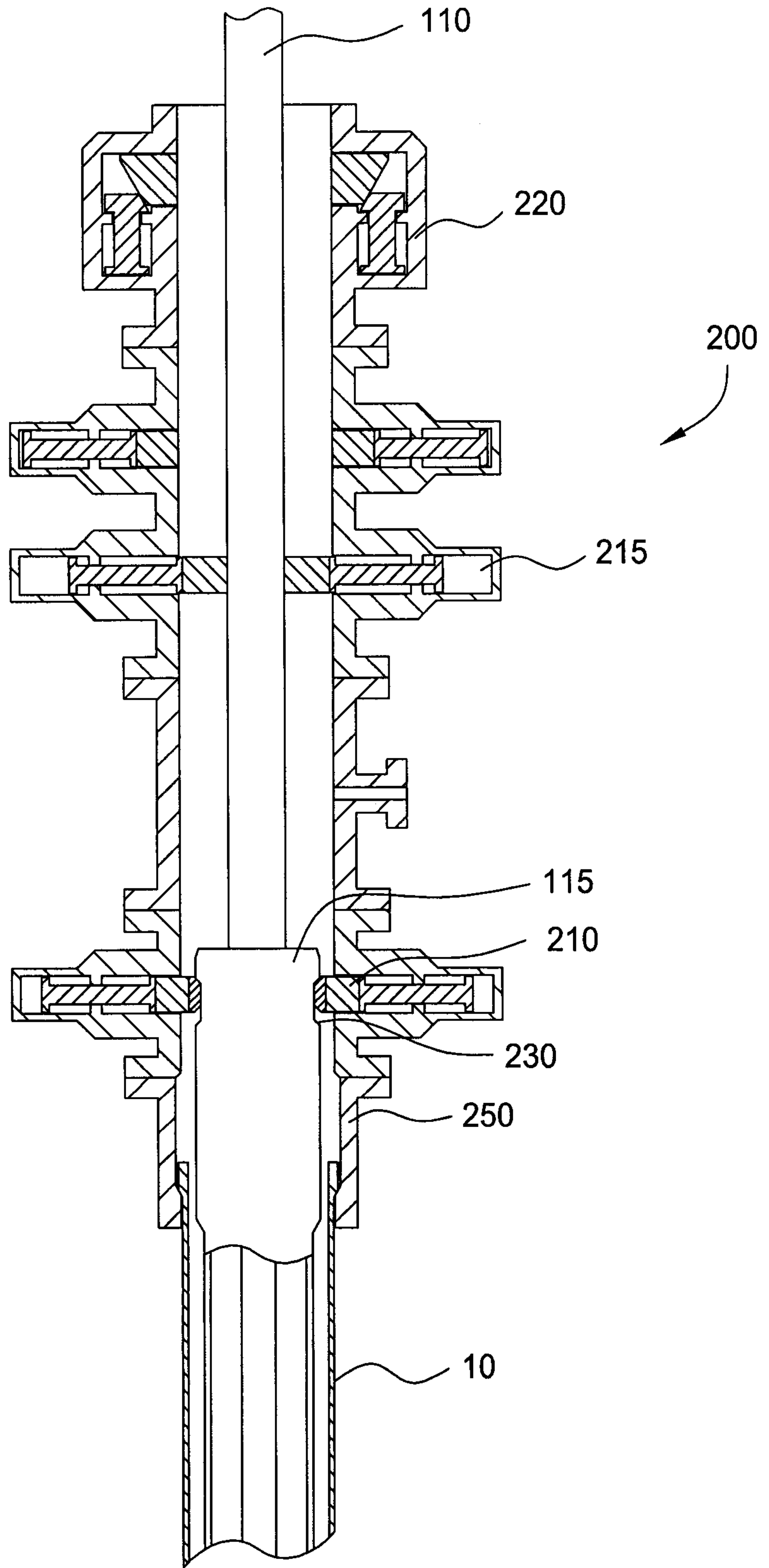

FIG. 2

┌

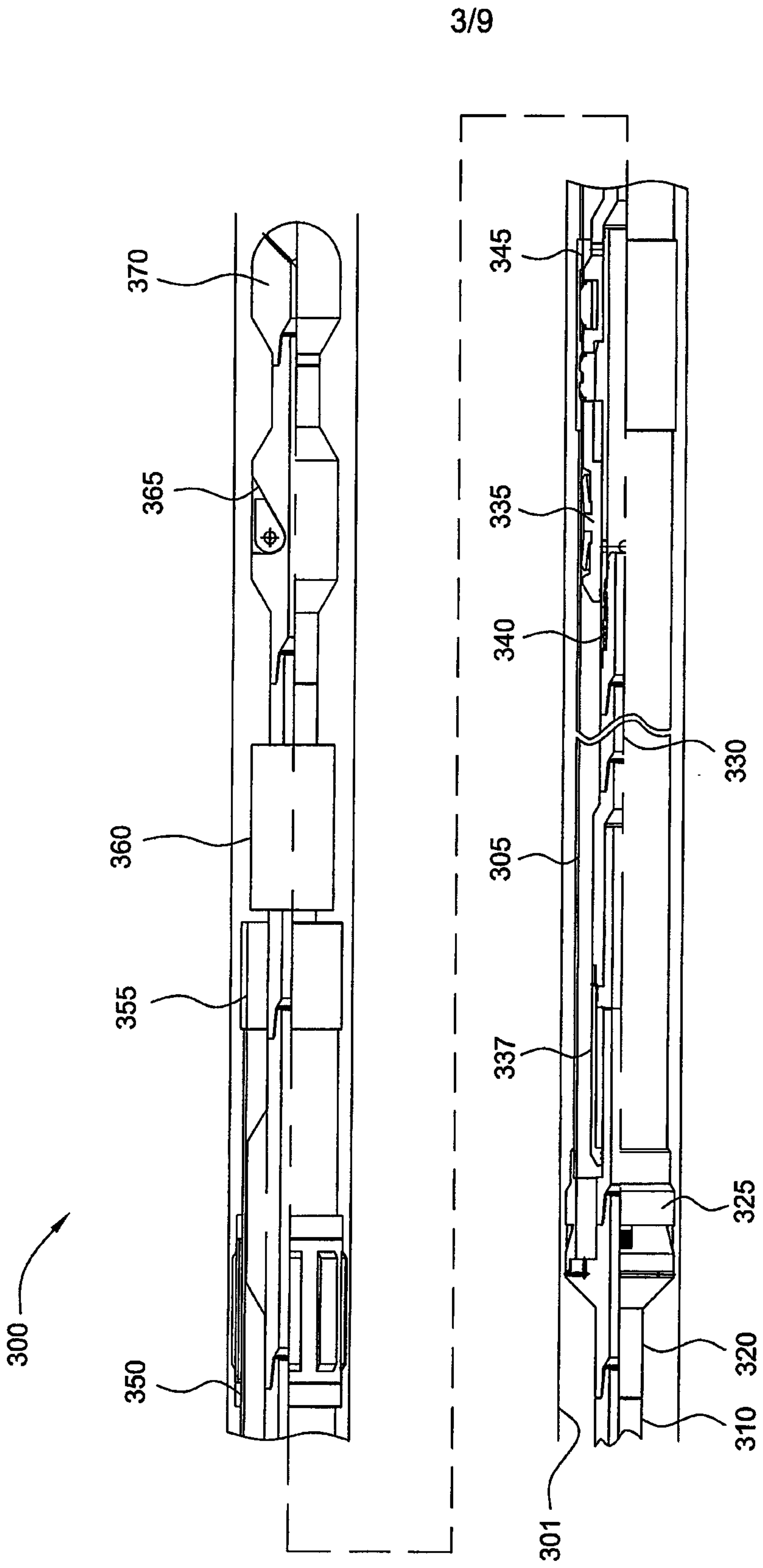

FIG. 3

L

┌

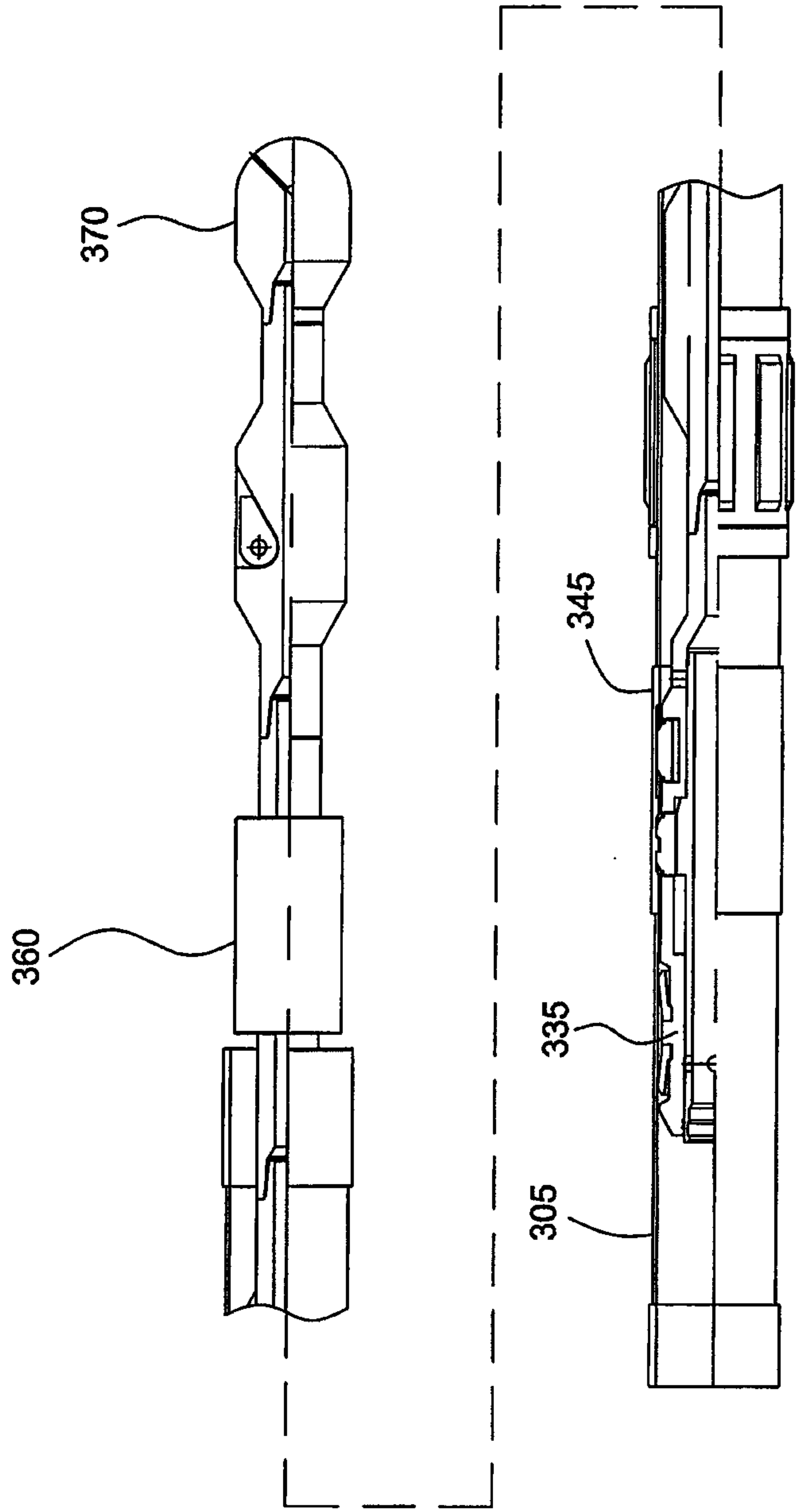

FIG. 4

└

┌

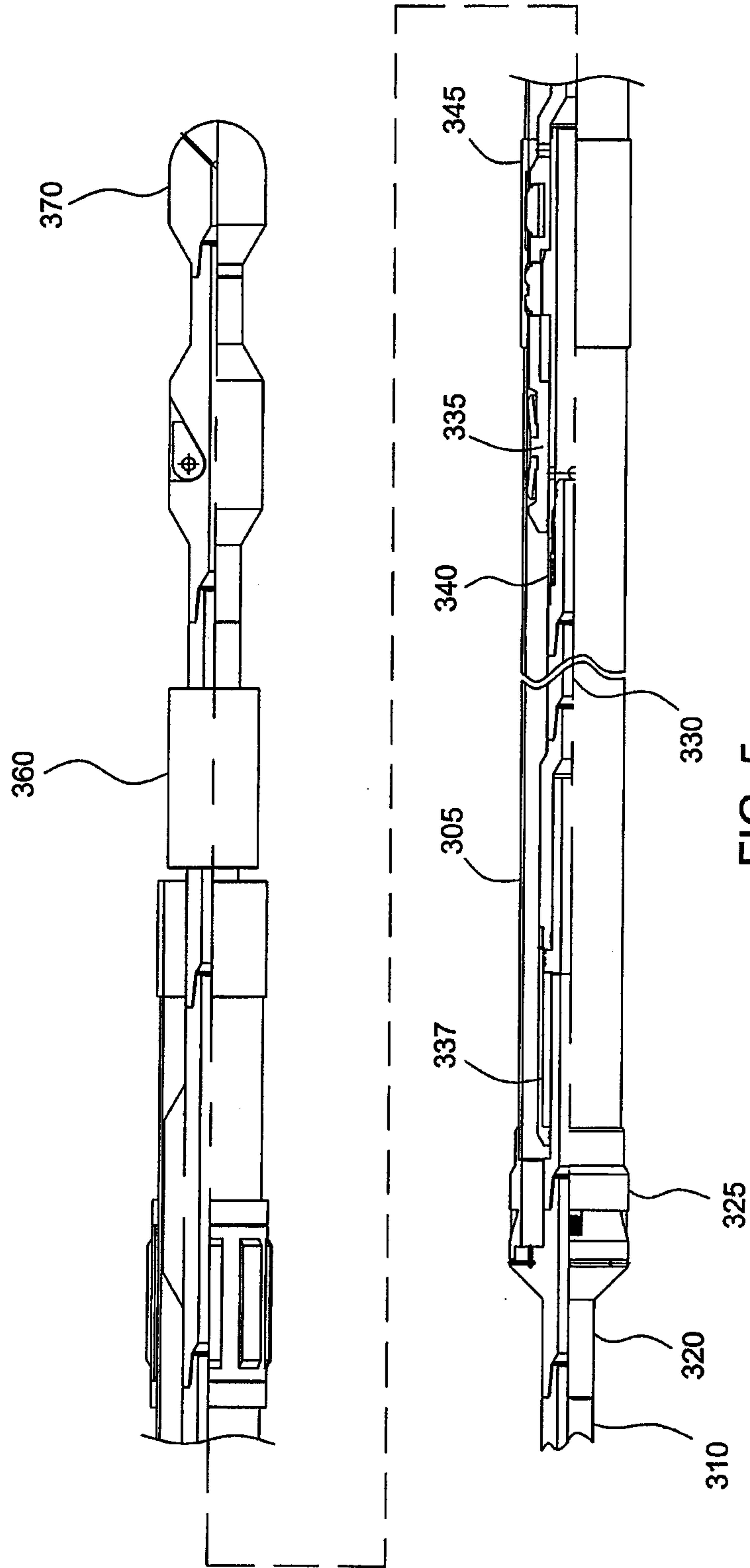

FIG. 5

└

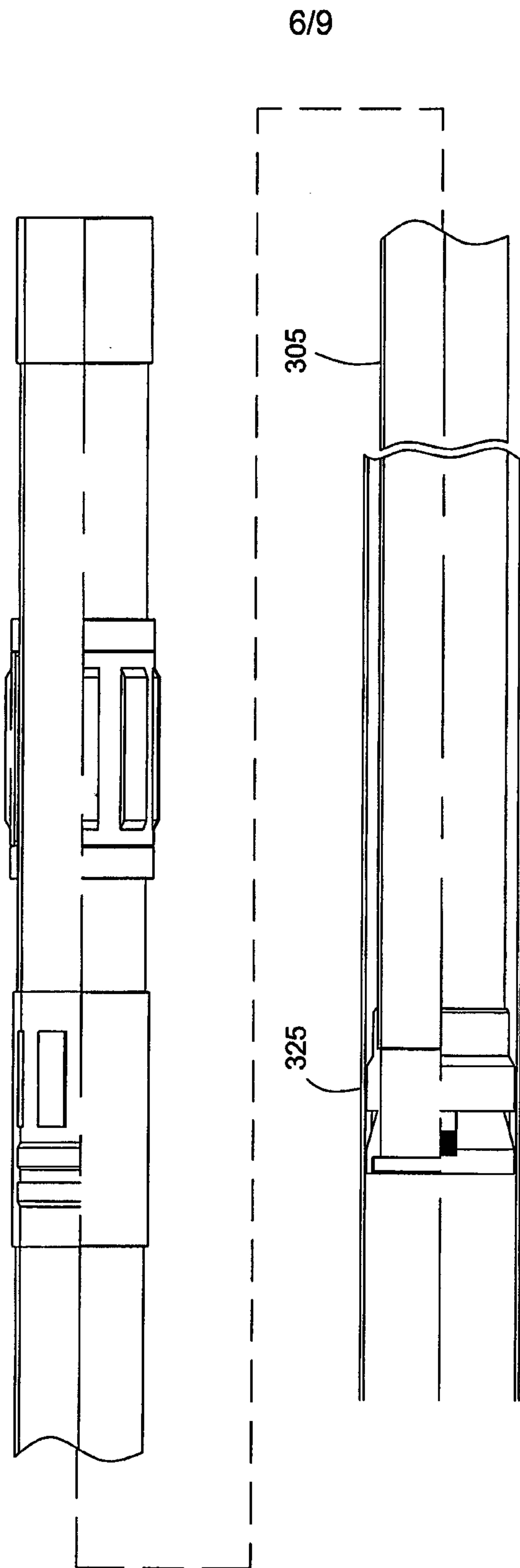

FIG. 6

┌

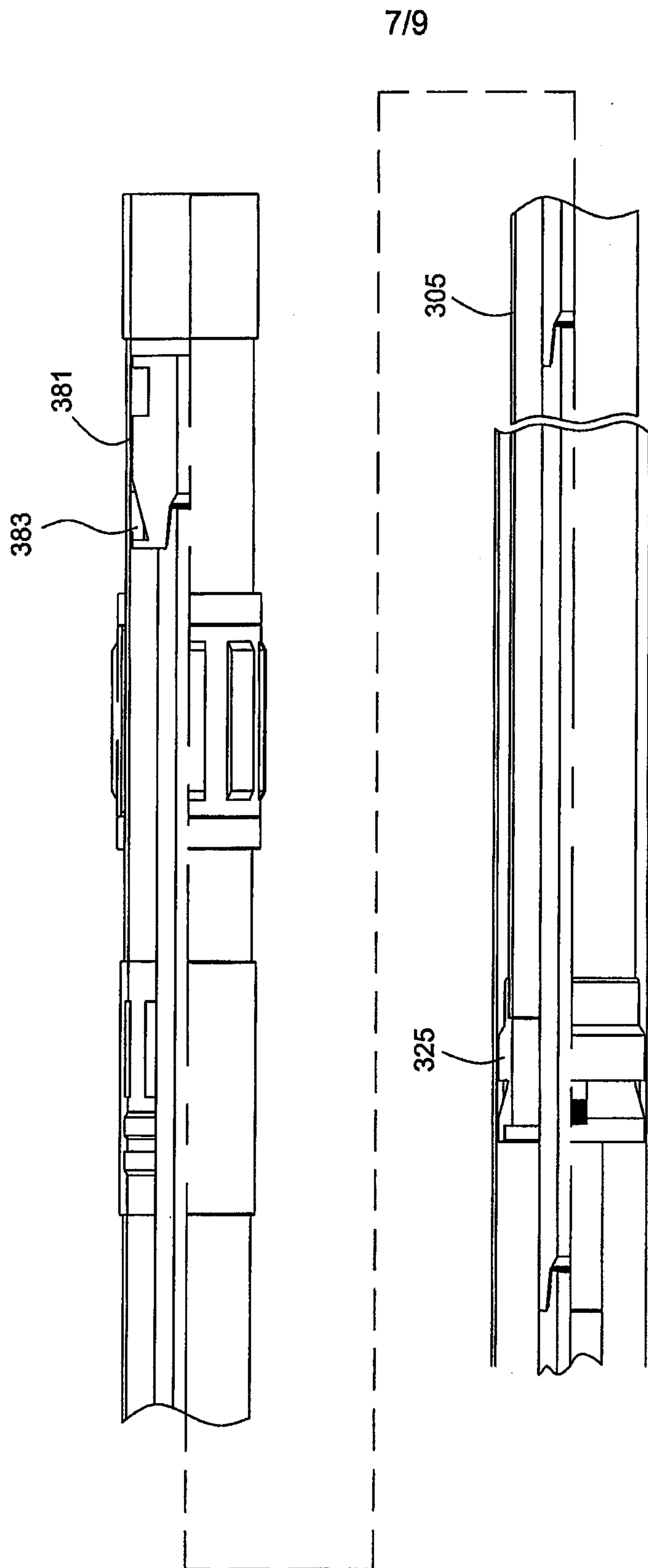

FIG. 7

└

┌

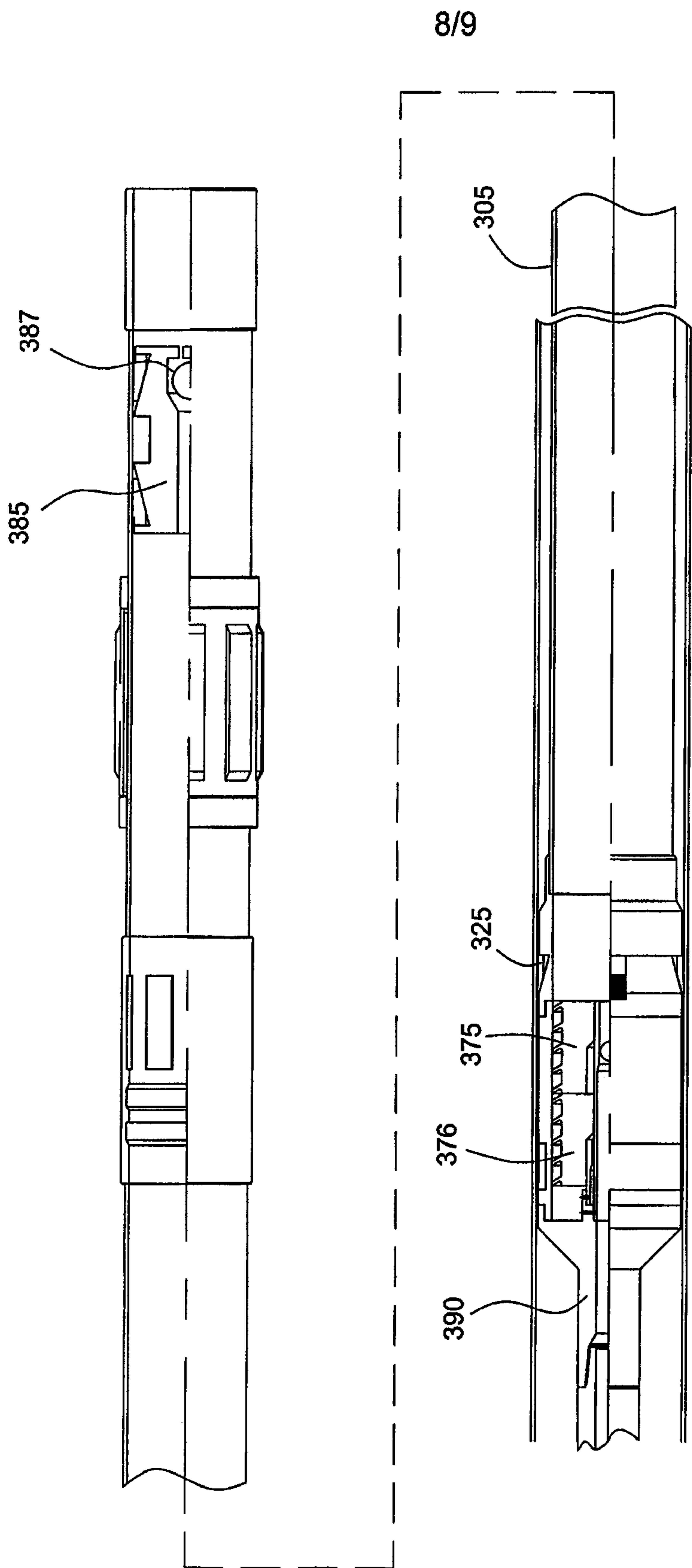

FIG. 8

└

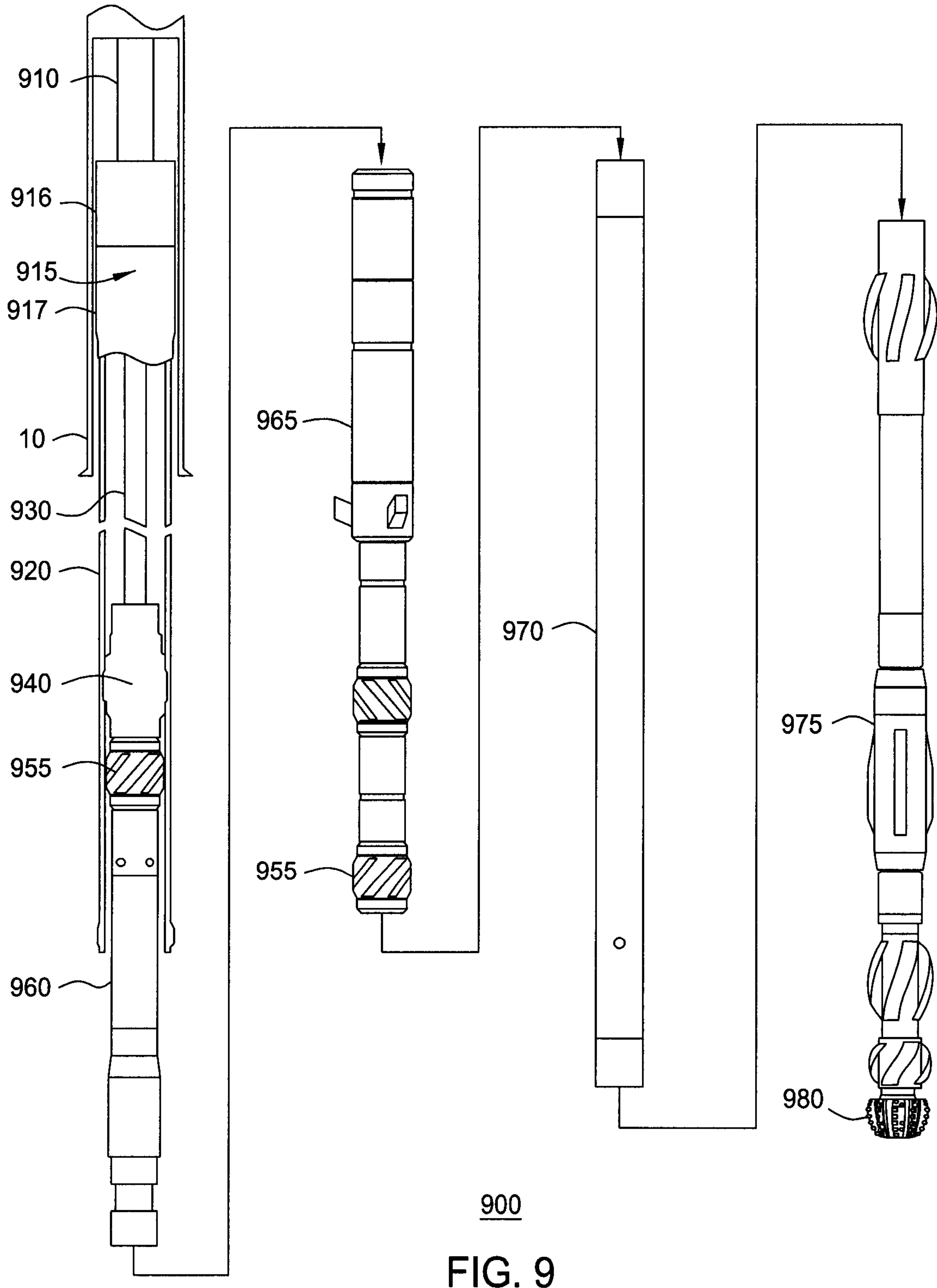

FIG. 9

