



- (51) International Patent Classification:
H04N 7/26 (2006.01) *H04N 7/34* (2006.01)
- (21) International Application Number:
PCT/US2013/049472
- (22) International Filing Date:
5 July 2013 (05.07.2013)
- (25) Filing Language: English
- (26) Publication Language: English
- (30) Priority Data:

61/669,546	9 July 2012 (09.07.2012)	US
61/707,611	28 September 2012 (28.09.2012)	US
61/707,538	28 September 2012 (28.09.2012)	US
61/707,666	28 September 2012 (28.09.2012)	US
13/935,393	3 July 2013 (03.07.2013)	US
- (71) Applicant: **QUALCOMM INCORPORATED** [US/US];
ATTN: International IP Administration, 5775 Morehouse Drive, San Diego, California 92121-1714 (US).

- (72) Inventors: **RAPAKA, Krishnakanth**; 5775 Morehouse Drive, San Diego, California 92121-1714 (US). **CHEN, Ji-anle**; 5775 Morehouse Drive, San Diego, California 92121-1714 (US). **KARCZEWICZ, Marta**; 5775 Morehouse Drive, San Diego, California 92121-1714 (US).
- (74) Agent: **ARNO, Thomas R.**; KNOBBE MARTENS OLSON & BEAR LLP, 2040 Main Street, Fourteenth Floor, Irvine, California 92614 (US).
- (81) Designated States (*unless otherwise indicated, for every kind of national protection available*): AE, AG, AL, AM, AO, AT, AU, AZ, BA, BB, BG, BH, BN, BR, BW, BY, BZ, CA, CH, CL, CN, CO, CR, CU, CZ, DE, DK, DM, DO, DZ, EC, EE, EG, ES, FI, GB, GD, GE, GH, GM, GT, HN, HR, HU, ID, IL, IN, IS, JP, KE, KG, KN, KP, KR, KZ, LA, LC, LK, LR, LS, LT, LU, LY, MA, MD, ME, MG, MK, MN, MW, MX, MY, MZ, NA, NG, NI, NO, NZ, OM, PA, PE, PG, PH, PL, PT, QA, RO, RS, RU, RW, SC, SD, SE, SG, SK, SL, SM, ST, SV, SY, TH, TJ, TM, TN, TR, TT, TZ, UA, UG, US, UZ, VC, VN, ZA, ZM, ZW.

[Continued on next page]

(54) Title: SKIP TRANSFORM AND RESIDUAL CODING MODE EXTENSION FOR DIFFERENCE DOMAIN INTRA PREDICTION

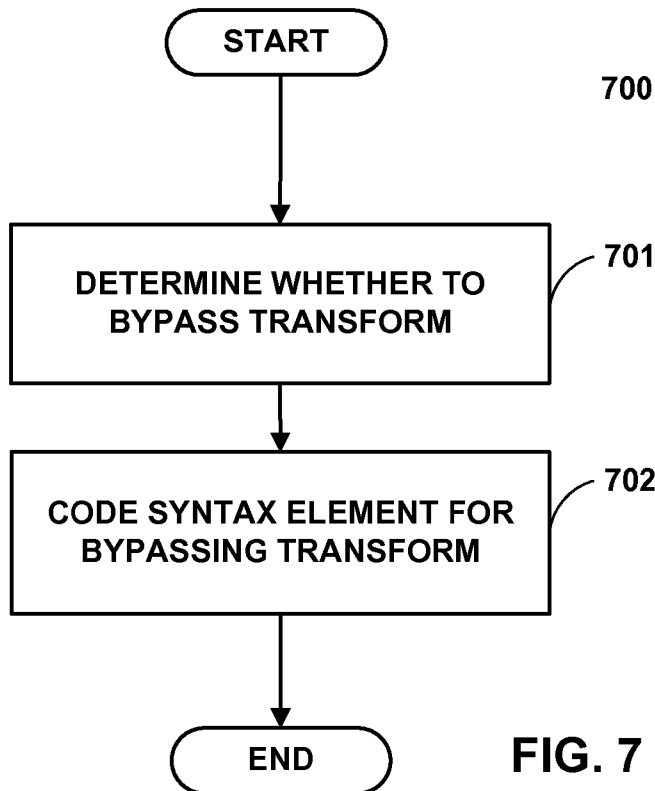

FIG. 7

(57) Abstract: An apparatus for coding video information according to certain aspects includes a memory unit and a processor in communication with the memory unit. The memory unit stores difference video information associated with a difference video layer of pixel information derived from a difference between an enhancement layer and a corresponding base layer of the video information. The processor determines a value of a video unit based on the difference video layer. The processor is further configured to refrain from performing a transform and residual coding of the determined value of the video unit.

WO 2014/011502 A1

(84) Designated States (*unless otherwise indicated, for every kind of regional protection available*): ARIPO (BW, GH, GM, KE, LR, LS, MW, MZ, NA, RW, SD, SL, SZ, TZ, UG, ZM, ZW), Eurasian (AM, AZ, BY, KG, KZ, RU, TJ, TM), European (AL, AT, BE, BG, CH, CY, CZ, DE, DK, EE, ES, FI, FR, GB, GR, HR, HU, IE, IS, IT, LT, LU, LV, MC, MK, MT, NL, NO, PL, PT, RO, RS, SE, SI, SK, SM, TR), OAPI (BF, BJ, CF, CG, CI, CM, GA, GN, GQ, GW, KM, ML, MR, NE, SN, TD, TG).

Declarations under Rule 4.17:

- *as to applicant's entitlement to apply for and be granted a patent (Rule 4.17(ii))*
- *as to the applicant's entitlement to claim the priority of the earlier application (Rule 4.17(iii))*

Published:

- *with international search report (Art. 21(3))*

SKIP TRANSFORM AND RESIDUAL CODING MODE EXTENSION FOR DIFFERENCE DOMAIN INTRA PREDICTION

TECHNICAL FIELD

[0001] This disclosure relates to video coding.

BACKGROUND

[0002] Digital video capabilities can be incorporated into a wide range of devices, including digital televisions, digital direct broadcast systems, wireless broadcast systems, personal digital assistants (PDAs), laptop or desktop computers, tablet computers, e-book readers, digital cameras, digital recording devices, digital media players, video gaming devices, video game consoles, cellular or satellite radio telephones, so-called “smart phones,” video conferencing devices, video streaming devices, and the like. Digital video devices implement video coding techniques, such as those described in the standards defined by MPEG-2, MPEG-4, ITU-T H.263, ITU-T H.264/MPEG-4, Part 10, Advanced Video Coding (AVC), the High Efficiency Video Coding (HEVC) standard presently under development, and extensions of such standards. The video devices may transmit, receive, encode, decode, and/or store digital video information more efficiently by implementing such video coding techniques.

[0003] Video coding techniques include spatial (intra-picture) prediction and/or temporal (inter-picture) prediction to reduce or remove redundancy inherent in video sequences. For block-based video coding, a video slice (e.g., a video frame or a portion of a video frame) may be partitioned into video blocks, which may also be referred to as treeblocks, coding units (CUs) and/or coding nodes. Video blocks in an intra-coded (I) slice of a picture are encoded using spatial prediction with respect to reference samples in neighboring blocks in the same picture. Video blocks in an inter-coded (P or B) slice of a picture may use spatial prediction with respect to reference samples in neighboring blocks in the same picture or temporal prediction with respect to reference samples in other reference pictures. Pictures may be referred to as frames, and reference pictures may be referred to as reference frames.

[0004] Spatial or temporal prediction results in a predictive block for a block to be coded. Residual data represents pixel differences between the original block to be coded and the predictive block. An inter-coded block is encoded according to a motion vector that points to a block of reference samples forming the predictive block, and the

residual data indicating the difference between the coded block and the predictive block. An intra-coded block is encoded according to an intra-coding mode and the residual data. For further compression, the residual data may be transformed from the pixel domain to a transform domain, resulting in residual transform coefficients, which then may be quantized. The quantized transform coefficients, initially arranged in a two-dimensional array, may be scanned in order to produce a one-dimensional vector of transform coefficients, and entropy coding may be applied to achieve even more compression.

SUMMARY

[0005] In general, this disclosure describes techniques related to scalable video coding (SVC). In some examples, DC mode may be used for intra prediction in the difference domain, and DC prediction may be performed without using the neighboring difference pixels. For example, the neighboring difference pixels may not be used in calculating the Prediction Unit (PU) for a current pixel in the difference domain. The DC value for the current PU may be set to 0 or offset by an offset value.

[0006] In some examples, most probable modes for difference domain intra prediction may be determined, and the Most Probable Mode (MPM) list may be defined based on the modes that are determined to be most probable for difference domain intra prediction.

[0007] In some examples, performing a transform, such as discrete cosine transform (DCT), and entropy coding of quantized residue may be skipped in difference domain intra prediction if the coding of transform tree and residue data would not lead to better rate-distortion trade-off, and the bypassing of transform tree and entropy coding of residue can be accomplished by indicating that no residual data exists for a coding unit (CU).

[0008] An apparatus for coding video information according to certain aspects includes a memory unit and a processor in communication with the memory unit. The memory unit stores difference video information associated with a difference video layer of pixel information derived from a difference between an enhancement layer and a corresponding base layer of the video information. The processor determines a DC prediction value for a video unit associated with the difference video layer while refraining from using pixel information from a neighboring area of the video unit, wherein the DC prediction value is equal to zero or is offset by an offset value. The DC

prediction value is a prediction value used in intra prediction based at least on an average of neighboring video units of the video unit. The processor further determines a value of the video unit based at least in part on the DC prediction value.

[0009] An apparatus for coding video information according to certain aspects includes a memory unit and a processor in communication with the memory unit. The memory unit stores difference video information associated with a difference video layer of pixel information derived from a difference between an enhancement layer and a corresponding reconstructed base layer of the video information. The processor determines a Most Probable Mode (MPM) list associated with the difference video layer based on the characteristics of the difference video layer, and determines a value of a current video unit based on the difference video layer and the MPM list.

[0010] An apparatus for coding video information according to certain aspects includes a memory unit and a processor in communication with the memory unit. The memory unit stores difference video information associated with a difference video layer of pixel information derived from a difference between an enhancement layer and a corresponding base layer of the video information. The processor determines a value of a video unit based on the difference video layer. The processor is further configured to refrain from performing a transform and residual coding of the determined value of the video unit.

[0011] The details of one or more examples are set forth in the accompanying drawings and the description below. Other features, objects, and advantages will be apparent from the description and drawings, and from the claims.

BRIEF DESCRIPTION OF DRAWINGS

[0012] FIG. 1 is a block diagram illustrating an example video encoding and decoding system that may utilize techniques in accordance with aspects described in this disclosure.

[0013] FIG. 2 is a block diagram illustrating an example of a video encoder that may implement techniques in accordance with aspects described in this disclosure.

[0014] FIG. 3 is a block diagram illustrating an example of a video decoder that may implement techniques in accordance with aspects described in this disclosure.

[0015] FIG. 4A is a conceptual diagram illustrating one DC mode extension according to aspects of this disclosure.

[0016] FIG. 4B is a conceptual diagram illustrating another DC mode extension

according to aspects of this disclosure.

[0017] FIG. 4C is a flowchart illustrating an example method for determining a DC prediction value according to aspects of this disclosure.

[0018] FIG. 5 is a flowchart illustrating an example method for defining the Most Probable Mode (MPM) list according to aspects of this disclosure.

[0019] FIG. 5A is a flowchart illustrating another example method for determining the most probable modes for difference domain intra prediction according to aspects of this disclosure.

[0020] FIG. 6 is a flowchart illustrating an example method for coding an enhancement layer in intra prediction mode according to aspects of this disclosure.

[0021] FIG. 7 is a flowchart illustrating an example method for coding information regarding whether residual data exists according to aspects of this disclosure.

[0022] FIG. 7A is a flowchart illustrating another example method for bypassing transform tree and residual coding in difference domain according to aspects of this disclosure.

DETAILED DESCRIPTION

[0023] The techniques described in this disclosure generally relate to scalable video coding (SVC). For example, the techniques may be related to, and used with or within, a High Efficiency Video Coding (HEVC) scalable video coding (SVC) extension. In an SVC extension, there could be multiple layers of video information. The layer at the very bottom level may serve as a base layer (BL), and the layer at the very top may serve as an enhanced layer (EL). The “enhanced layer” is sometimes referred to as an “enhancement layer,” and these terms may be used interchangeably. All layers in the middle may serve as either or both ELs or BLs. For example, a layer in the middle may be an EL for the layers below it, such as the base layer or any intervening enhancement layers, and at the same time serve as a BL for the enhancement layers above it.

[0024] For purposes of illustration only, the techniques described in the disclosure are described with examples including only two layers (e.g., lower level layer such as the base layer, and a higher level layer such as the enhanced layer). It should be understood that the examples described in this disclosure can be extended to examples with multiple base layers and enhancement layers as well.

[0025] Video coding standards include ITU-T H.261, ISO/IEC MPEG-1 Visual, ITU-T H.262 or ISO/IEC MPEG-2 Visual, ITU-T H.263, ISO/IEC MPEG-4 Visual and ITU-T

H.264 (also known as ISO/IEC MPEG-4 AVC), including its Scalable Video Coding (SVC) and Multiview Video Coding (MVC) extensions. In addition, a new video coding standard, namely High Efficiency Video Coding (HEVC), is being developed by the Joint Collaboration Team on Video Coding (JCT-VC) of ITU-T Video Coding Experts Group (VCEG) and ISO/IEC Motion Picture Experts Group (MPEG). A recent draft of HEVC is available from http://wg11.sc29.org/jct/doc_end_user/current_document.php?id=5885/JCTVC-I1003-v2, as of June 7, 2012. Another recent draft of the HEVC standard, referred to as "HEVC Working Draft 7" is downloadable from http://phenix.it-sudparis.eu/jct/doc_end_user/documents/9_Geneva/wg11/JCTVC-I1003-v3.zip, as of June 7, 2012. The full citation for the HEVC Working Draft 7 is document HCTVC-I1003, Bross et al., "High Efficiency Video Coding (HEVC) Text Specification Draft 7," Joint Collaborative Team on Video Coding (JCT-VC) of ITU-T SG16 WP3 and ISO/IEC JTC1/SC29/WG11, 9th Meeting: Geneva, Switzerland, April 27, 2012 to May 7, 2012. Each of these references is incorporated by reference in its entirety.

[0026] Scalable video coding (SVC) may be used to provide quality (also referred to as signal-to-noise (SNR)) scaling, spatial scaling and/or temporal scaling. An enhanced layer may have different spatial resolution than base layer. For example, the spatial aspect ratio between EL and BL can be 1.0, 1.5, 2.0 or other different ratios. In other words, the spatial aspect of the EL may equal 1.0, 1.5, or 2.0 times the spatial aspect of the BL. In some examples, the scaling factor of the EL may be greater than the BL. For example, a size of pictures in the EL may be greater than a size of pictures in the BL. In this way, it may be possible, although not a limitation, that the spatial resolution of the EL is larger than the spatial resolution of the BL.

[0027] In coding an enhancement layer, intra prediction may be performed using either pixel domain or difference domain. Intra prediction is based on neighboring pixels and the intra prediction mode. Some examples of intra prediction modes include vertical mode, horizontal mode, DC mode, planar mode, angular mode. Additional intra prediction modes may also be available. For example, in HEVC, 18 intra prediction modes are available for 4x4 blocks and 36 intra prediction modes for 8x8 blocks. In DC mode, the neighboring pixel values are used in intra prediction for the current pixel.

[0028] In SVC, the difference domain may refer to a set of difference pixels formed by subtracting the reconstructed base layer pixels from the reconstructed pixels in the enhancement layer, or vice versa. As explained above, difference domain can be used

for intra prediction. However, the difference pixels in the difference domain are generally high frequency components, for example, due to loss from quantization loss. Because the difference domain pixels are generally high frequency, using DC mode as the intra prediction mode may not yield good prediction and therefore lead to poor rate-distortion trade-off (R-D trade-off). Compared to traditional low frequency signals, the correlation between the current difference pixel and the neighboring difference pixels may be weak. This is because in the difference domain, the DC is generally already compensated from the base layer. Therefore, further difference DC correlation with the neighboring difference pixels is usually weak. Accordingly, it would be advantageous to modify DC prediction in the difference domain to obtain better prediction results.

[0029] In addition, due to the high frequency nature of difference domain pixels, the most probable modes for intra prediction for the pixel domain may not lead to good prediction results in the difference domain. In non-difference domain coding, e.g., pixel domain coding, the most probable mode occurrences may be different from that of difference domain coding. For example, the correlation between pixels in the current prediction unit and the neighboring pixels may be stronger in the pixel domain, as compared to the difference domain. Accordingly, it would be advantageous to modify the most probable mode list determination for difference domain coding.

[0030] Further, the high frequency nature of difference domain pixels may lead to poor rate-distortion trade-off for a Coding Unit (CU) when transform tree and residual coding is performed on the difference domain pixels. Accordingly, it would be advantageous to bypass transform tree and residual coding in difference domain intra prediction for a Coding Unit (CU).

[0031] The techniques described in this disclosure may address issues relating to DC intra prediction in the difference domain. The techniques may not consider neighboring difference pixels in performing intra prediction in the difference domain in order to reduce the effect of the high frequency nature of the difference domain pixels. Instead, the techniques may define a DC mode extension to HEVC, which may be referred to as the Zero DC Mode, in which the DC value in DC prediction is set to 0. The techniques may also define another DC mode extension to HEVC, which may be referred to as the DC Offset Mode, in which the DC value in DC prediction is offset by an offset value of -1 or 1. The sign of the offset value may be signaled in the bitstream. The techniques may add additional syntax elements to code the DC mode extensions. The techniques may also change the coding order of the syntax elements to make the coding faster and

more efficient.

[0032] The techniques may also determine the most probable modes for intra prediction in difference domain coding and define the Most Probable Mode (MPM) list according to the modes determined to be most probable in difference domain coding.

[0033] Moreover, the techniques may also code information regarding whether residual data exists for a CU in difference domain intra mode. If performing a transform (e.g., DCT) tree and residue coding does not lead to better R-D tradeoff, transform and coding of residue may be skipped by indicating in the syntax that residual data does not exist. Or as a default, transform and coding of residue can be skipped in difference domain by always indicating that residual data does not exist.

[0034] Various aspects of the novel systems, apparatuses, and methods are described more fully hereinafter with reference to the accompanying drawings. This disclosure may, however, be embodied in many different forms and should not be construed as limited to any specific structure or function presented throughout this disclosure. Rather, these aspects are provided so that this disclosure will be thorough and complete, and will fully convey the scope of the disclosure to those skilled in the art. Based on the teachings herein one skilled in the art should appreciate that the scope of the disclosure is intended to cover any aspect of the novel systems, apparatuses, and methods disclosed herein, whether implemented independently of, or combined with, any other aspect of the invention. For example, an apparatus may be implemented or a method may be practiced using any number of the aspects set forth herein. In addition, the scope of the invention is intended to cover such an apparatus or method which is practiced using other structure, functionality, or structure and functionality in addition to or other than the various aspects of the invention set forth herein. It should be understood that any aspect disclosed herein may be embodied by one or more elements of a claim.

[0035] Although particular aspects are described herein, many variations and permutations of these aspects fall within the scope of the disclosure. Although some benefits and advantages of the preferred aspects are mentioned, the scope of the disclosure is not intended to be limited to particular benefits, uses, or objectives. Rather, aspects of the disclosure are intended to be broadly applicable to different wireless technologies, system configurations, networks, and transmission protocols, some of which are illustrated by way of example in the figures and in the following description of the preferred aspects. The detailed description and drawings are merely

illustrative of the disclosure rather than limiting, the scope of the disclosure being defined by the appended claims and equivalents thereof.

[0036] FIG. 1 is a block diagram illustrating an example video encoding and decoding system that may utilize techniques in accordance with aspects described in this disclosure. As shown in FIG. 1, system 10 includes a source device 12 that provides encoded video data to be decoded at a later time by a destination device 14. In particular, source device 12 provides the video data to destination device 14 via a computer-readable medium 16. Source device 12 and destination device 14 may comprise any of a wide range of devices, including desktop computers, notebook (e.g., laptop) computers, tablet computers, set-top boxes, telephone handsets such as so-called “smart” phones, so-called “smart” pads, televisions, cameras, display devices, digital media players, video gaming consoles, video streaming device, or the like. In some cases, source device 12 and destination device 14 may be equipped for wireless communication.

[0037] Destination device 14 may receive the encoded video data to be decoded via computer-readable medium 16. Computer-readable medium 16 may comprise any type of medium or device capable of moving the encoded video data from source device 12 to destination device 14. In one example, computer-readable medium 16 may comprise a communication medium to enable source device 12 to transmit encoded video data directly to destination device 14 in real-time. The encoded video data may be modulated according to a communication standard, such as a wireless communication protocol, and transmitted to destination device 14. The communication medium may comprise any wireless or wired communication medium, such as a radio frequency (RF) spectrum or one or more physical transmission lines. The communication medium may form part of a packet-based network, such as a local area network, a wide-area network, or a global network such as the Internet. The communication medium may include routers, switches, base stations, or any other equipment that may be useful to facilitate communication from source device 12 to destination device 14.

[0038] In some examples, encoded data may be output from output interface 22 to a storage device. Similarly, encoded data may be accessed from the storage device by input interface. The storage device may include any of a variety of distributed or locally accessed data storage media such as a hard drive, Blu-ray discs, DVDs, CD-ROMs, flash memory, volatile or non-volatile memory, or any other suitable digital storage media for storing encoded video data. In a further example, the storage device may

correspond to a file server or another intermediate storage device that may store the encoded video generated by source device 12. Destination device 14 may access stored video data from the storage device via streaming or download. The file server may be any type of server capable of storing encoded video data and transmitting that encoded video data to the destination device 14. Example file servers include a web server (e.g., for a website), an FTP server, network attached storage (NAS) devices, or a local disk drive. Destination device 14 may access the encoded video data through any standard data connection, including an Internet connection. This may include a wireless channel (e.g., a Wi-Fi connection), a wired connection (e.g., DSL, cable modem, etc.), or a combination of both that is suitable for accessing encoded video data stored on a file server. The transmission of encoded video data from the storage device may be a streaming transmission, a download transmission, or a combination thereof.

[0039] The techniques of this disclosure are not necessarily limited to wireless applications or settings. The techniques may be applied to video coding in support of any of a variety of multimedia applications, such as over-the-air television broadcasts, cable television transmissions, satellite television transmissions, Internet streaming video transmissions, such as dynamic adaptive streaming over HTTP (DASH), digital video that is encoded onto a data storage medium, decoding of digital video stored on a data storage medium, or other applications. In some examples, system 10 may be configured to support one-way or two-way video transmission to support applications such as video streaming, video playback, video broadcasting, and/or video telephony.

[0040] In the example of FIG. 1, source device 12 includes video source 18, video encoder 20, and output interface 22. Destination device 14 includes input interface 28, video decoder 30, and display device 32. In accordance with this disclosure, video encoder 20 of source device 12 may be configured to apply the techniques for coding a bitstream including video data conforming to multiple standards or standard extensions. In other examples, a source device and a destination device may include other components or arrangements. For example, source device 12 may receive video data from an external video source 18, such as an external camera. Likewise, destination device 14 may interface with an external display device, rather than including an integrated display device.

[0041] The illustrated system 10 of FIG. 1 is merely one example. Techniques for determining candidates for a candidate list for motion vector predictors for a current block may be performed by any digital video encoding and/or decoding device.

Although generally the techniques of this disclosure are performed by a video encoding device, the techniques may also be performed by a video encoder/decoder, typically referred to as a "CODEC." Moreover, the techniques of this disclosure may also be performed by a video preprocessor. Source device 12 and destination device 14 are merely examples of such coding devices in which source device 12 generates coded video data for transmission to destination device 14. In some examples, devices 12, 14 may operate in a substantially symmetrical manner such that each of devices 12, 14 include video encoding and decoding components. Hence, system 10 may support one-way or two-way video transmission between video devices 12, 14, e.g., for video streaming, video playback, video broadcasting, or video telephony.

[0042] Video source 18 of source device 12 may include a video capture device, such as a video camera, a video archive containing previously captured video, and/or a video feed interface to receive video from a video content provider. As a further alternative, video source 18 may generate computer graphics-based data as the source video, or a combination of live video, archived video, and computer-generated video. In some cases, if video source 18 is a video camera, source device 12 and destination device 14 may form so-called camera phones or video phones. As mentioned above, however, the techniques described in this disclosure may be applicable to video coding in general, and may be applied to wireless and/or wired applications. In each case, the captured, pre-captured, or computer-generated video may be encoded by video encoder 20. The encoded video information may then be output by output interface 22 onto a computer-readable medium 16.

[0043] Computer-readable medium 16 may include transient media, such as a wireless broadcast or wired network transmission, or storage media (that is, non-transitory storage media), such as a hard disk, flash drive, compact disc, digital video disc, Blu-ray disc, or other computer-readable media. In some examples, a network server (not shown) may receive encoded video data from source device 12 and provide the encoded video data to destination device 14, e.g., via network transmission, direct wired communication, etc. Similarly, a computing device of a medium production facility, such as a disc stamping facility, may receive encoded video data from source device 12 and produce a disc containing the encoded video data. Therefore, computer-readable medium 16 may be understood to include one or more computer-readable media of various forms, in various examples.

[0044] Input interface 28 of destination device 14 receives information from computer-

readable medium 16. The information of computer-readable medium 16 may include syntax information defined by video encoder 20, which is also used by video decoder 30, that includes syntax elements that describe characteristics and/or processing of blocks and other coded units, e.g., GOPs. Display device 32 displays the decoded video data to a user, and may comprise any of a variety of display devices such as a cathode ray tube (CRT), a liquid crystal display (LCD), a plasma display, an organic light emitting diode (OLED) display, or another type of display device.

[0045] Video encoder 20 and video decoder 30 may operate according to a video coding standard, such as the High Efficiency Video Coding (HEVC) standard presently under development, and may conform to the HEVC Test Model (HM). Alternatively, video encoder 20 and video decoder 30 may operate according to other proprietary or industry standards, such as the ITU-T H.264 standard, alternatively referred to as MPEG-4, Part 10, Advanced Video Coding (AVC), or extensions of such standards. The techniques of this disclosure, however, are not limited to any particular coding standard, including but not limited to any of the standards listed above. Other examples of video coding standards include MPEG-2 and ITU-T H.263. Although not shown in FIG. 1, in some aspects, video encoder 20 and video decoder 30 may each be integrated with an audio encoder and decoder, and may include appropriate MUX-DEMUX units, or other hardware and software, to handle encoding of both audio and video in a common data stream or separate data streams. If applicable, MUX-DEMUX units may conform to the ITU H.223 multiplexer protocol, or other protocols such as the user datagram protocol (UDP).

[0046] Video encoder 20 and video decoder 30 each may be implemented as any of a variety of suitable encoder circuitry, such as one or more microprocessors, digital signal processors (DSPs), application specific integrated circuits (ASICs), field programmable gate arrays (FPGAs), discrete logic, software, hardware, firmware or any combinations thereof. When the techniques are implemented partially in software, a device may store instructions for the software in a suitable, non-transitory computer-readable medium and execute the instructions in hardware using one or more processors to perform the techniques of this disclosure. Each of video encoder 20 and video decoder 30 may be included in one or more encoders or decoders, either of which may be integrated as part of a combined encoder/decoder (CODEC) in a respective device. A device including video encoder 20 and/or video decoder 30 may comprise an integrated circuit, a microprocessor, and/or a wireless communication device, such as a cellular telephone.

[0047] The JCT-VC is working on development of the HEVC standard. The HEVC standardization efforts are based on an evolving model of a video coding device referred to as the HEVC Test Model (HM). The HM presumes several additional capabilities of video coding devices relative to existing devices according to, e.g., ITU-T H.264/AVC. For example, whereas H.264 provides nine intra-prediction encoding modes, the HM may provide as many as thirty-three intra-prediction encoding modes.

[0048] In general, the working model of the HM describes that a video frame or picture may be divided into a sequence of treeblocks or largest coding units (LCU) that include both luma and chroma samples. Syntax data within a bitstream may define a size for the LCU, which is a largest coding unit in terms of the number of pixels. A slice includes a number of consecutive treeblocks in coding order. A video frame or picture may be partitioned into one or more slices. Each treeblock may be split into coding units (CUs) according to a quadtree. In general, a quadtree data structure includes one node per CU, with a root node corresponding to the treeblock. If a CU is split into four sub-CUs, the node corresponding to the CU includes four leaf nodes, each of which corresponds to one of the sub-CUs.

[0049] Each node of the quadtree data structure may provide syntax data for the corresponding CU. For example, a node in the quadtree may include a split flag, indicating whether the CU corresponding to the node is split into sub-CUs. Syntax elements for a CU may be defined recursively, and may depend on whether the CU is split into sub-CUs. If a CU is not split further, it is referred to as a leaf-CU. In this disclosure, four sub-CUs of a leaf-CU will also be referred to as leaf-CUs even if there is no explicit splitting of the original leaf-CU. For example, if a CU at 16x16 size is not split further, the four 8x8 sub-CUs will also be referred to as leaf-CUs although the 16x16 CU was never split.

[0050] A CU has a similar purpose as a macroblock of the H.264 standard, except that a CU does not have a size distinction. For example, a treeblock may be split into four child nodes (also referred to as sub-CUs), and each child node may in turn be a parent node and be split into another four child nodes. A final, unsplit child node, referred to as a leaf node of the quadtree, comprises a coding node, also referred to as a leaf-CU. Syntax data associated with a coded bitstream may define a maximum number of times a treeblock may be split, referred to as a maximum CU depth, and may also define a minimum size of the coding nodes. Accordingly, a bitstream may also define a smallest coding unit (SCU). This disclosure uses the term “block” to refer to any of a CU, PU,

or TU, in the context of HEVC, or similar data structures in the context of other standards (e.g., macroblocks and sub-blocks thereof in H.264/AVC).

[0051] A CU includes a coding node and prediction units (PUs) and transform units (TUs) associated with the coding node. A size of the CU corresponds to a size of the coding node and must be square in shape. The size of the CU may range from 8x8 pixels up to the size of the treeblock with a maximum of 64x64 pixels or greater. Each CU may contain one or more PUs and one or more TUs. Syntax data associated with a CU may describe, for example, partitioning of the CU into one or more PUs. Partitioning modes may differ between whether the CU is skip or direct mode encoded, intra-prediction mode encoded, or inter-prediction mode encoded. PUs may be partitioned to be non-square in shape. Syntax data associated with a CU may also describe, for example, partitioning of the CU into one or more TUs according to a quadtree. A TU can be square or non-square (e.g., rectangular) in shape.

[0052] The HEVC standard allows for transformations according to TUs, which may be different for different CUs. The TUs are typically sized based on the size of PUs within a given CU defined for a partitioned LCU, although this may not always be the case. The TUs are typically the same size or smaller than the PUs. In some examples, residual samples corresponding to a CU may be subdivided into smaller units using a quadtree structure known as “residual quad tree” (RQT). The leaf nodes of the RQT may be referred to as transform units (TUs). Pixel difference values associated with the TUs may be transformed to produce transform coefficients, which may be quantized.

[0053] A leaf-CU may include one or more prediction units (PUs). In general, a PU represents a spatial area corresponding to all or a portion of the corresponding CU, and may include data for retrieving a reference sample for the PU. Moreover, a PU includes data related to prediction. For example, when the PU is intra-mode encoded, data for the PU may be included in a residual quadtree (RQT), which may include data describing an intra-prediction mode for a TU corresponding to the PU. As another example, when the PU is inter-mode encoded, the PU may include data defining one or more motion vectors for the PU. The data defining the motion vector for a PU may describe, for example, a horizontal component of the motion vector, a vertical component of the motion vector, a resolution for the motion vector (e.g., one-quarter pixel precision or one-eighth pixel precision), a reference picture to which the motion vector points, and/or a reference picture list (e.g., List 0, List 1, or List C) for the motion vector.

[0054] A leaf-CU having one or more PUs may also include one or more transform units (TUs). The transform units may be specified using an RQT (also referred to as a TU quadtree structure), as discussed above. For example, a split flag may indicate whether a leaf-CU is split into four transform units. Then, each transform unit may be split further into further sub-TUs. When a TU is not split further, it may be referred to as a leaf-TU. Generally, for intra coding, all the leaf-TUs belonging to a leaf-CU share the same intra prediction mode. That is, the same intra-prediction mode is generally applied to calculate predicted values for all TUs of a leaf-CU. For intra coding, a video encoder may calculate a residual value for each leaf-TU using the intra prediction mode, as a difference between the portion of the CU corresponding to the TU and the original block. A TU is not necessarily limited to the size of a PU. Thus, TUs may be larger or smaller than a PU. For intra coding, a PU may be collocated with a corresponding leaf-TU for the same CU. In some examples, the maximum size of a leaf-TU may correspond to the size of the corresponding leaf-CU.

[0055] Moreover, TUs of leaf-CUs may also be associated with respective quadtree data structures, referred to as residual quadtrees (RQTs). That is, a leaf-CU may include a quadtree indicating how the leaf-CU is partitioned into TUs. The root node of a TU quadtree generally corresponds to a leaf-CU, while the root node of a CU quadtree generally corresponds to a treeblock (or LCU). TUs of the RQT that are not split are referred to as leaf-TUs. In general, this disclosure uses the terms CU and TU to refer to leaf-CU and leaf-TU, respectively, unless noted otherwise.

[0056] A video sequence typically includes a series of video frames or pictures. A group of pictures (GOP) generally comprises a series of one or more of the video pictures. A GOP may include syntax data in a header of the GOP, a header of one or more of the pictures, or elsewhere, that describes a number of pictures included in the GOP. Each slice of a picture may include slice syntax data that describes an encoding mode for the respective slice. Video encoder 20 typically operates on video blocks within individual video slices in order to encode the video data. A video block may correspond to a coding node within a CU. The video blocks may have fixed or varying sizes, and may differ in size according to a specified coding standard.

[0057] As an example, the HM supports prediction in various PU sizes. Assuming that the size of a particular CU is $2N \times 2N$, the HM supports intra-prediction in PU sizes of $2N \times 2N$ or $N \times N$, and inter-prediction in symmetric PU sizes of $2N \times 2N$, $2N \times N$, $N \times 2N$, or $N \times N$. The HM also supports asymmetric partitioning for inter-prediction in PU sizes of

$2N \times nU$, $2N \times nD$, $nL \times 2N$, and $nR \times 2N$. In asymmetric partitioning, one direction of a CU is not partitioned, while the other direction is partitioned into 25% and 75%. The portion of the CU corresponding to the 25% partition is indicated by an “n” followed by an indication of “Up,” “Down,” “Left,” or “Right.” Thus, for example, “ $2N \times nU$ ” refers to a $2N \times 2N$ CU that is partitioned horizontally with a $2N \times 0.5N$ PU on top and a $2N \times 1.5N$ PU on bottom.

[0058] In this disclosure, “ $N \times N$ ” and “N by N” may be used interchangeably to refer to the pixel dimensions of a video block in terms of vertical and horizontal dimensions, e.g., 16×16 pixels or 16 by 16 pixels. In general, a 16×16 block will have 16 pixels in a vertical direction ($y = 16$) and 16 pixels in a horizontal direction ($x = 16$). Likewise, an $N \times N$ block generally has N pixels in a vertical direction and N pixels in a horizontal direction, where N represents a nonnegative integer value. The pixels in a block may be arranged in rows and columns. Moreover, blocks need not necessarily have the same number of pixels in the horizontal direction as in the vertical direction. For example, blocks may comprise $N \times M$ pixels, where M is not necessarily equal to N.

[0059] Following intra-predictive or inter-predictive coding using the PUs of a CU, video encoder 20 may calculate residual data for the TUs of the CU. The PUs may comprise syntax data describing a method or mode of generating predictive pixel data in the spatial domain (also referred to as the pixel domain) and the TUs may comprise coefficients in the transform domain following application of a transform, e.g., a discrete cosine transform (DCT), an integer transform, a wavelet transform, or a conceptually similar transform to residual video data. The residual data may correspond to pixel differences between pixels of the unencoded picture and prediction values corresponding to the PUs. Video encoder 20 may form the TUs including the residual data for the CU, and then transform the TUs to produce transform coefficients for the CU.

[0060] Following any transforms to produce transform coefficients, video encoder 20 may perform quantization of the transform coefficients. Quantization generally refers to a process in which transform coefficients are quantized to possibly reduce the amount of data used to represent the coefficients, providing further compression. The quantization process may reduce the bit depth associated with some or all of the coefficients. For example, an n-bit value may be rounded down to an m-bit value during quantization, where n is greater than m.

[0061] Following quantization, the video encoder may scan the transform coefficients,

producing a one-dimensional vector from the two-dimensional matrix including the quantized transform coefficients. The scan may be designed to place higher energy (and therefore lower frequency) coefficients at the front of the array and to place lower energy (and therefore higher frequency) coefficients at the back of the array. In some examples, video encoder 20 may utilize a predefined scan order to scan the quantized transform coefficients to produce a serialized vector that can be entropy encoded. In other examples, video encoder 20 may perform an adaptive scan. After scanning the quantized transform coefficients to form a one-dimensional vector, video encoder 20 may entropy encode the one-dimensional vector, e.g., according to context-adaptive variable length coding (CAVLC), context-adaptive binary arithmetic coding (CABAC), syntax-based context-adaptive binary arithmetic coding (SBAC), Probability Interval Partitioning Entropy (PIPE) coding or another entropy encoding methodology. Video encoder 20 may also entropy encode syntax elements associated with the encoded video data for use by video decoder 30 in decoding the video data.

[0062] To perform CABAC, video encoder 20 may assign a context within a context model to a symbol to be transmitted. The context may relate to, for example, whether neighboring values of the symbol are non-zero or not. To perform CAVLC, video encoder 20 may select a variable length code for a symbol to be transmitted. Codewords in VLC may be constructed such that relatively shorter codes correspond to more probable symbols, while longer codes correspond to less probable symbols. In this way, the use of VLC may achieve a bit savings over, for example, using equal-length codewords for each symbol to be transmitted. The probability determination may be based on a context assigned to the symbol.

[0063] Video encoder 20 may further send syntax data, such as block-based syntax data, frame-based syntax data, and GOP-based syntax data, to video decoder 30, e.g., in a frame header, a block header, a slice header, or a GOP header. The GOP syntax data may describe a number of frames in the respective GOP, and the frame syntax data may indicate an encoding/prediction mode used to encode the corresponding frame.

[0064] FIG. 2 is a block diagram illustrating an example of a video encoder that may implement techniques in accordance with aspects described in this disclosure. Video encoder 20 may be configured to perform any or all of the techniques of this disclosure. As one example, mode select unit 40 may be configured to perform any or all of the techniques described in this disclosure. However, aspects of this disclosure are not so limited. In some examples, the techniques described in this disclosure may be shared

among the various components of video encoder 20. In some examples, in addition to or instead of, a processor (not shown) may be configured to perform any or all of the techniques described in this disclosure.

[0065] In some embodiments, the mode select unit 40, the intra prediction unit 46 (or another component of the mode select unit 40, shown or not shown), or another component of the encoder 20 (shown or not shown) may perform the techniques of this disclosure. For example, the mode select unit 40 may receive video data for encoding, which may be encoded into a base layer and corresponding one or more enhancement layers. The mode select unit 40, the intra prediction unit 46, or another appropriate unit of the encoder 20 may determine the DC prediction value for a video unit associated with the difference video layer while refraining from using pixel information from the neighboring area of the video unit. The DC prediction value may be equal to zero or may be offset by an offset value. The appropriate unit of the encoder 20 can determine a value of the video unit based at least in part on the DC prediction value. For example, the appropriate unit of the encoder 20 may generate a prediction unit (PU) for the video unit. The encoder 20 can encode the video unit and signal the DC prediction value in a bitstream (e.g., using one or more syntax elements, etc.).

[0066] In certain embodiments, the mode select unit 40, the intra prediction unit 46 (or another component of the mode select unit 40, shown or not shown), or another component of the encoder 20 (shown or not shown) may receive video data to be encoded and determine the Most Probable Mode (MPM) list for a video unit associated with the difference video layer. The encoder 20 can encode the video unit and signal the MPM list in a bitstream.

[0067] In other embodiments, the mode select unit 40, the intra prediction unit 46, the motion estimation unit 42, the motion compensation unit 44 (or another component of the mode select unit 40, shown or not shown), or another component of the encoder 20 (shown or not shown) may receive video data to be encoded and determine the value of a video unit based on the difference video layer. The appropriate unit of the encoder 20 may be configured to refrain from performing a transform and residual coding of the determined value of the video unit. The encoder 20 may encode one or more corresponding syntax elements that indicate that the transform and residual coding should not be performed.

[0068] Video encoder 20 may perform intra- and inter-coding of video blocks within video slices. Intra-coding relies on spatial prediction to reduce or remove spatial

redundancy in video within a given video frame or picture. Inter-coding relies on temporal prediction to reduce or remove temporal redundancy in video within adjacent frames or pictures of a video sequence. Intra-mode (I mode) may refer to any of several spatial based coding modes. Inter-modes, such as uni-directional prediction (P mode) or bi-prediction (B mode), may refer to any of several temporal-based coding modes.

[0069] As shown in FIG. 2, video encoder 20 receives a current video block within a video frame to be encoded. In the example of FIG. 1, video encoder 20 includes mode select unit 40, reference frame memory 64, summer 50, transform processing unit 52, quantization unit 54, and entropy encoding unit 56. Mode select unit 40, in turn, includes motion compensation unit 44, motion estimation unit 42, intra-prediction unit 46, and partition unit 48. For video block reconstruction, video encoder 20 also includes inverse quantization unit 58, inverse transform unit 60, and summer 62. A deblocking filter (not shown in FIG. 2) may also be included to filter block boundaries to remove blockiness artifacts from reconstructed video. If desired, the deblocking filter would typically filter the output of summer 62. Additional filters (in loop or post loop) may also be used in addition to the deblocking filter. Such filters are not shown for brevity, but if desired, may filter the output of summer 50 (as an in-loop filter).

[0070] During the encoding process, video encoder 20 receives a video frame or slice to be coded. The frame or slice may be divided into multiple video blocks. Motion estimation unit 42 and motion compensation unit 44 perform inter-predictive coding of the received video block relative to one or more blocks in one or more reference frames to provide temporal prediction. Intra-prediction unit 46 may alternatively perform intra-predictive coding of the received video block relative to one or more neighboring blocks in the same frame or slice as the block to be coded to provide spatial prediction. Video encoder 20 may perform multiple coding passes, e.g., to select an appropriate coding mode for each block of video data.

[0071] Moreover, partition unit 48 may partition blocks of video data into sub-blocks, based on evaluation of previous partitioning schemes in previous coding passes. For example, partition unit 48 may initially partition a frame or slice into LCUs, and partition each of the LCUs into sub-CUs based on rate-distortion analysis (e.g., rate-distortion optimization). Mode select unit 40 may further produce a quadtree data structure indicative of partitioning of an LCU into sub-CUs. Leaf-node CUs of the quadtree may include one or more PUs and one or more TUs.

[0072] Mode select unit 40 may select one of the coding modes, intra or inter, e.g.,

based on error results, and provides the resulting intra- or inter-coded block to summer 50 to generate residual block data and to summer 62 to reconstruct the encoded block for use as a reference frame. Mode select unit 40 also provides syntax elements, such as motion vectors, intra-mode indicators, partition information, and other such syntax information, to entropy encoding unit 56.

[0073] Motion estimation unit 42 and motion compensation unit 44 may be highly integrated, but are illustrated separately for conceptual purposes. Motion estimation, performed by motion estimation unit 42, is the process of generating motion vectors, which estimate motion for video blocks. A motion vector, for example, may indicate the displacement of a PU of a video block within a current video frame or picture relative to a predictive block within a reference frame (or other coded unit) relative to the current block being coded within the current frame (or other coded unit). A predictive block is a block that is found to closely match the block to be coded, in terms of pixel difference, which may be determined by sum of absolute difference (SAD), sum of square difference (SSD), or other difference metrics. In some examples, video encoder 20 may calculate values for sub-integer pixel positions of reference pictures stored in reference frame memory 64. For example, video encoder 20 may interpolate values of one-quarter pixel positions, one-eighth pixel positions, or other fractional pixel positions of the reference picture. Therefore, motion estimation unit 42 may perform a motion search relative to the full pixel positions and fractional pixel positions and output a motion vector with fractional pixel precision.

[0074] Motion estimation unit 42 calculates a motion vector for a PU of a video block in an inter-coded slice by comparing the position of the PU to the position of a predictive block of a reference picture. The reference picture may be selected from a first reference picture list (List 0) or a second reference picture list (List 1), each of which identify one or more reference pictures stored in reference frame memory 64. Motion estimation unit 42 sends the calculated motion vector to entropy encoding unit 56 and motion compensation unit 44.

[0075] Motion compensation, performed by motion compensation unit 44, may involve fetching or generating the predictive block based on the motion vector determined by motion estimation unit 42. Again, motion estimation unit 42 and motion compensation unit 44 may be functionally integrated, in some examples. Upon receiving the motion vector for the PU of the current video block, motion compensation unit 44 may locate the predictive block to which the motion vector points in one of the reference picture

lists. Summer 50 forms a residual video block by subtracting pixel values of the predictive block from the pixel values of the current video block being coded, forming pixel difference values, as discussed below. In general, motion estimation unit 42 performs motion estimation relative to luma components, and motion compensation unit 44 uses motion vectors calculated based on the luma components for both chroma components and luma components. Mode select unit 40 may also generate syntax elements associated with the video blocks and the video slice for use by video decoder 30 in decoding the video blocks of the video slice.

[0076] Intra-prediction unit 46 may intra-predict a current block, as an alternative to the inter-prediction performed by motion estimation unit 42 and motion compensation unit 44, as described above. In particular, intra-prediction unit 46 may determine an intra-prediction mode to use to encode a current block. In some examples, intra-prediction unit 46 may encode a current block using various intra-prediction modes, e.g., during separate encoding passes, and intra-prediction unit 46 (or mode select unit 40, in some examples) may select an appropriate intra-prediction mode to use from the tested modes.

[0077] For example, intra-prediction unit 46 may calculate rate-distortion values using a rate-distortion analysis for the various tested intra-prediction modes, and select the intra-prediction mode having the best rate-distortion characteristics among the tested modes. Rate-distortion analysis generally determines an amount of distortion (or error) between an encoded block and an original, unencoded block that was encoded to produce the encoded block, as well as a bitrate (that is, a number of bits) used to produce the encoded block. Intra-prediction unit 46 may calculate ratios from the distortions and rates for the various encoded blocks to determine which intra-prediction mode exhibits the best rate-distortion value for the block.

[0078] After selecting an intra-prediction mode for a block, intra-prediction unit 46 may provide information indicative of the selected intra-prediction mode for the block to entropy encoding unit 56. Entropy encoding unit 56 may encode the information indicating the selected intra-prediction mode. Video encoder 20 may include in the transmitted bitstream configuration data, which may include a plurality of intra-prediction mode index tables and a plurality of modified intra-prediction mode index tables (also referred to as codeword mapping tables), definitions of encoding contexts for various blocks, and indications of a most probable intra-prediction mode, an intra-prediction mode index table, and a modified intra-prediction mode index table to use for

each of the contexts.

[0079] Video encoder 20 forms a residual video block by subtracting the prediction data from mode select unit 40 from the original video block being coded. Summer 50 represents the component or components that perform this subtraction operation. Transform processing unit 52 applies a transform, such as a discrete cosine transform (DCT) or a conceptually similar transform, to the residual block, producing a video block comprising residual transform coefficient values. Transform processing unit 52 may perform other transforms which are conceptually similar to DCT. Wavelet transforms, integer transforms, sub-band transforms or other types of transforms could also be used. In any case, transform processing unit 52 applies the transform to the residual block, producing a block of residual transform coefficients. The transform may convert the residual information from a pixel value domain to a transform domain, such as a frequency domain. Transform processing unit 52 may send the resulting transform coefficients to quantization unit 54. Quantization unit 54 quantizes the transform coefficients to further reduce bit rate. The quantization process may reduce the bit depth associated with some or all of the coefficients. The degree of quantization may be modified by adjusting a quantization parameter. In some examples, quantization unit 54 may then perform a scan of the matrix including the quantized transform coefficients. Alternatively, entropy encoding unit 56 may perform the scan.

[0080] Following quantization, entropy encoding unit 56 entropy codes the quantized transform coefficients. For example, entropy encoding unit 56 may perform context adaptive variable length coding (CAVLC), context adaptive binary arithmetic coding (CABAC), syntax-based context-adaptive binary arithmetic coding (SBAC), probability interval partitioning entropy (PIPE) coding or another entropy coding technique. In the case of context-based entropy coding, context may be based on neighboring blocks. Following the entropy coding by entropy encoding unit 56, the encoded bitstream may be transmitted to another device (e.g., video decoder 30) or archived for later transmission or retrieval.

[0081] Inverse quantization unit 58 and inverse transform unit 60 apply inverse quantization and inverse transformation, respectively, to reconstruct the residual block in the pixel domain, e.g., for later use as a reference block. Motion compensation unit 44 may calculate a reference block by adding the residual block to a predictive block of one of the frames of reference frame memory 64. Motion compensation unit 44 may also apply one or more interpolation filters to the reconstructed residual block to

calculate sub-integer pixel values for use in motion estimation. Summer 62 adds the reconstructed residual block to the motion compensated prediction block produced by motion compensation unit 44 to produce a reconstructed video block for storage in reference frame memory 64. The reconstructed video block may be used by motion estimation unit 42 and motion compensation unit 44 as a reference block to inter-code a block in a subsequent video frame.

[0082] FIG. 3 is a block diagram illustrating an example of a video decoder that may implement techniques in accordance with aspects described in this disclosure. Video decoder 30 may be configured to perform any or all of the techniques of this disclosure. As one example, motion compensation unit 72 and/or intra prediction unit 74 may be configured to perform any or all of the techniques described in this disclosure. However, aspects of this disclosure are not so limited. In some examples, the techniques described in this disclosure may be shared among the various components of video decoder 30. In some examples, in addition to or instead of, a processor (not shown) may be configured to perform any or all of the techniques described in this disclosure.

[0083] In some embodiments, the entropy decoding unit 70, the intra prediction unit 74, or another component of the decoder 30 (shown or not shown) may perform the techniques of this disclosure. For example, the entropy decoding unit 70 may receive an encoded video bitstream, which may encode data relating to a base layer and corresponding one or more enhancement layers. The intra prediction unit 74 or another appropriate unit of the decoder 30 may determine the DC prediction value for a video unit associated with the difference video layer while refraining from using pixel information from the neighboring area of the video unit. The entropy decoding unit 70 or another component of the decoder 30 may be configured to decode the video unit and to receive the DC prediction value in a bitstream. The DC prediction value may be equal to zero or may be offset by an offset value. The appropriate unit of the decoder 30 can determine a value of the video unit based at least in part on the DC prediction value. For example, the appropriate unit of the decoder 30 may generate a prediction unit (PU) for the video unit.

[0084] In certain embodiments, the entropy decoding unit 70 or another component of the decoder 30 (shown or not shown) may receive an encoded video bitstream. The intra prediction unit 74 or another appropriate unit of the decoder 30 may determine the Most Probable Mode (MPM) list for a video unit associated with the difference video

layer. The entropy decoding unit 70 or another component of the decoder 30 may be configured to decode the video unit and receive the MPM list in a bitstream or at least partially derive the MPM list from information in a bitstream.

[0085] In other embodiments, the entropy decoding unit 70 or another component of the decoder 30 (shown or not shown) may receive an encoded video bitstream and decode the video bitstream based upon a plurality of syntax elements. The intra prediction unit 74, the motion compensation unit 72, or another appropriate unit of the decoder 30 may determine the value of a video unit based on the difference video layer. The appropriate unit of the decoder 30 may be configured to refrain from performing a transform and residual coding of the determined value of the video unit. For example, the appropriate unit of the decoder 30 may refrain from performing the transform and residual coding of the determined value of the video unit when one or more corresponding syntax elements indicate that the transform and residual coding should not be performed.

[0086] In the example of FIG. 3, video decoder 30 includes an entropy decoding unit 70, motion compensation unit 72, intra prediction unit 74, inverse quantization unit 76, inverse transformation unit 78, reference frame memory 82 and summer 80. Video decoder 30 may, in some examples, perform a decoding pass generally reciprocal to the encoding pass described with respect to video encoder 20 (FIG. 2). Motion compensation unit 72 may generate prediction data based on motion vectors received from entropy decoding unit 70, while intra-prediction unit 74 may generate prediction data based on intra-prediction mode indicators received from entropy decoding unit 70.

[0087] During the decoding process, video decoder 30 receives an encoded video bitstream that represents video blocks of an encoded video slice and associated syntax elements from video encoder 20. Entropy decoding unit 70 of video decoder 30 entropy decodes the bitstream to generate quantized coefficients, motion vectors or intra-prediction mode indicators, and other syntax elements. Entropy decoding unit 70 forwards the motion vectors to and other syntax elements to motion compensation unit 72. Video decoder 30 may receive the syntax elements at the video slice level and/or the video block level.

[0088] When the video slice is coded as an intra-coded (I) slice, intra prediction unit 74 may generate prediction data for a video block of the current video slice based on a signaled intra prediction mode and data from previously decoded blocks of the current frame or picture. When the video frame is coded as an inter-coded (e.g., B, P or GPB) slice, motion compensation unit 72 produces predictive blocks for a video block of the

current video slice based on the motion vectors and other syntax elements received from entropy decoding unit 70. The predictive blocks may be produced from one of the reference pictures within one of the reference picture lists. Video decoder 30 may construct the reference frame lists, List 0 and List 1, using default construction techniques based on reference pictures stored in reference frame memory 92. Motion compensation unit 72 determines prediction information for a video block of the current video slice by parsing the motion vectors and other syntax elements, and uses the prediction information to produce the predictive blocks for the current video block being decoded. For example, motion compensation unit 72 uses some of the received syntax elements to determine a prediction mode (e.g., intra- or inter-prediction) used to code the video blocks of the video slice, an inter-prediction slice type (e.g., B slice, P slice, or GPB slice), construction information for one or more of the reference picture lists for the slice, motion vectors for each inter-encoded video block of the slice, inter-prediction status for each inter-coded video block of the slice, and other information to decode the video blocks in the current video slice.

[0089] Motion compensation unit 72 may also perform interpolation based on interpolation filters. Motion compensation unit 72 may use interpolation filters as used by video encoder 20 during encoding of the video blocks to calculate interpolated values for sub-integer pixels of reference blocks. In this case, motion compensation unit 72 may determine the interpolation filters used by video encoder 20 from the received syntax elements and use the interpolation filters to produce predictive blocks.

[0090] Inverse quantization unit 76 inverse quantizes, e.g., de-quantizes, the quantized transform coefficients provided in the bitstream and decoded by entropy decoding unit 80. The inverse quantization process may include use of a quantization parameter QP_Y calculated by video decoder 30 for each video block in the video slice to determine a degree of quantization and, likewise, a degree of inverse quantization that should be applied.

[0091] Inverse transform unit 78 applies an inverse transform, e.g., an inverse DCT, an inverse integer transform, or a conceptually similar inverse transform process, to the transform coefficients in order to produce residual blocks in the pixel domain.

[0092] After motion compensation unit 82 generates the predictive block for the current video block based on the motion vectors and other syntax elements, video decoder 30 forms a decoded video block by summing the residual blocks from inverse transform unit 78 with the corresponding predictive blocks generated by motion compensation

unit 72. Summer 90 represents the component or components that perform this summation operation. If desired, a deblocking filter may also be applied to filter the decoded blocks in order to remove blockiness artifacts. Other loop filters (either in the coding loop or after the coding loop) may also be used to smooth pixel transitions, or otherwise improve the video quality. The decoded video blocks in a given frame or picture are then stored in reference picture memory 92, which stores reference pictures used for subsequent motion compensation. Reference frame memory 82 also stores decoded video for later presentation on a display device, such as display device 32 of FIG. 1.

[0093] FIG. 4A is a conceptual diagram illustrating one DC mode extension according to aspects of this disclosure. This DC mode extension may be referred to as “Zero DC Mode.” When coding an enhancement layer, pixel domain or difference domain may be used for intra prediction. The Zero DC Mode may be used when difference domain pixels are used for intra prediction. As explained above, the difference pixels for the current pixel and the neighboring pixels may be formed by taking the difference between the respective reconstructed enhancement layer pixels and the corresponding reconstructed base layer pixels. The difference pixels obtained by taking the difference may constitute the difference domain pixels. When intra prediction is performed in the difference domain, these difference pixels may be used for prediction. For example, to generate the prediction unit for the current enhancement layer pixel, the neighboring difference pixels may be used. DC mode is one of the available intra prediction modes, where the neighboring pixels are used in the prediction.

[0094] In HEVC Working Draft 7, DC intra prediction includes two steps: 1) deriving the DC value for the Prediction Unit for the current pixel and 2) filtering the DC value with the neighboring pixels. The DC value is derived according to the following equation:

$$\left(\sum_{x'=0}^{nS-1} p[x', -1] + \sum_{y'=0}^{nS-1} p[-1, y'] + nS \right) \gg (k+1), \text{ with } x, y = 0 \dots nS-1,$$

where $k = \text{Log}_2(nS)$

The derived DC value is filtered according to the following equations:

- Current PU pixel (0, 0) = (Left neighboring pixels (-1, 0) + 2 * DC value + Above neighboring pixels (0, -1) + 2) >> 2

- Current PU pixels (0, 1) to (0, nS - 1) = (Left neighboring pixels (-1, 0) to (-1, nS - 1) + 3 * DC value + 2) >> 2
- Current PU pixels (1, 0) to (nS-1, 0) = Above neighboring pixels (1, -1) to (nS-1, -1) + 3 * DC value + 2) >> 2

However, because the difference domain often contains many high frequency values, the correlation between the current pixel and the neighboring difference pixels may not be strong, and DC prediction using these values may not yield good prediction results.

[0095] In Zero DC Mode, one DC intra prediction mode according to the aspects of this disclosure, the neighboring difference pixels may not be considered in generating the prediction unit for the current pixel in the difference domain. Instead, the DC value may be set to 0. In addition, DC filtering may not be used for the prediction. By not considering the neighboring difference pixels and setting the DC value to 0, the effects of high frequency components in the difference domain in DC prediction can be reduced. Reduction of high frequency effects can lead to better rate distortion trade-off. In some embodiments, the Zero DC Mode may not be signaled to save coding bits. Instead, in difference domain intra prediction, Zero DC Mode may be presumed to be the default intra prediction mode when intra prediction is being performed using the difference domain.

[0096] Although the DC mode extension according to aspects of this disclosure has been described in terms of pixels, the DC mode extension described with respect to FIG. 4A may be implemented at various syntax levels, e.g., sequence, picture, frame, LCU, CU, PU, etc. In addition, all embodiments described with respect to FIG. 4A may be implemented separately, or in combination with one another.

[0097] FIG. 4B is a conceptual diagram illustrating another DC mode extension according to aspects of this disclosure. This DC mode extension may be referred to as "Offset DC Mode." The Offset DC Mode may also be used when difference domain pixels are used for intra prediction. In the Offset DC Mode, similar to the Zero DC Mode, neighboring difference pixels may not be considered in determining the prediction unit for the current enhancement layer pixel. Instead, the DC value may be offset by an offset value of 1 or -1. The sign of the offset value may be signaled in the bitstream. In one embodiment, only the sign of the offset may be signaled. For example, the sign of the offset may be signaled as "0" for an offset value of "1," and the sign of the offset may be signaled as "1" for an offset value of "-1." The DC offset value is added to the DC value. In some embodiments, the Zero DC Mode is not

signaled and assumed to be the default intra prediction mode in difference domain intra prediction. In such case, the DC value would be 0, and the offset value of 1 or -1 would be added to 0. In these embodiments, the DC value would be either -1, 0, or 1. As in the Zero DC Mode, the DC Offset Mode may not use DC filtering, in addition to not considering the neighboring difference pixels in intra prediction. The sign of the offset may be coded using CABAC equiprobable. In some embodiments, the Offset DC Mode can be split into two separate mode extensions, for example, as Offset DC Mode Plus1 and Offset DC Mode Minus1.

[0098] Although the DC mode extension according to aspects of this disclosure has been described in terms of pixels, the DC mode extension described with respect to FIG. 4B may be implemented at various syntax levels, e.g., sequence, picture, frame, LCU, CU, PU, etc. In addition, all embodiments described with respect to FIG. 4B may be implemented separately, or in combination with one another.

[0099] FIG. 4C is a flowchart illustrating an example method for determining a DC prediction value according to aspects of this disclosure. The process 400C may be performed by an encoder (e.g., the encoder as shown in FIG. 2, etc.) or a decoder (e.g., the decoder as shown in FIG. 3, etc.). The blocks of the process 400C are described with respect to the encoder 20 in FIG. 2, but the process 400C may be performed by other components, such as a decoder, as mentioned above. All embodiments described with respect to FIG. 4C may be implemented separately, or in combination with one another.

[00100] At block 401C, the encoder 20 determines a DC prediction value while refraining from using pixel information from a neighboring area of a video unit. A DC prediction value may refer to a prediction value used in intra prediction based on an average of neighboring video units of the video unit. Such prediction value may be the DC value in DC mode. Determining the DC prediction value while refraining from using pixel information from a neighboring area of the video unit may refer to, e.g., determining the DC prediction value without requiring access to the neighboring area of the video unit, or determining the DC prediction value without considering the neighboring area of the video unit. A video unit may be any unit of video data, and can include but is not limited to: a frame, a slice, a largest coding unit (LCU), a coding unit (CU), a block, a pixel, and a sub-pixel. The value of the video unit may be determined by generating a prediction unit (PU) for the video unit.

[00101] At block 402C, the encoder 20 determines a value of the video unit based

on the difference video information and based at least in part on the DC prediction value that is equal to zero or is offset by an offset value. The difference video information may refer to information associated with the difference domain. The value of the video unit may be determined by generating a prediction unit (PU) for the video unit.

[00102] In some embodiments, the video unit is a video unit for the difference video layer, and determining the value of the video unit includes performing intra prediction for the video unit based on the DC prediction value that is equal to zero or offset by the offset value. The encoder 20 determines the DC prediction value while refraining from using the pixel information from the neighboring area of the video unit. In some embodiments, the encoder 20 defines an intra prediction mode or flag to indicate that the video unit is a video unit for the difference video layer, and determining the value of the video unit includes performing intra prediction for the video unit based on the DC prediction value that is equal to zero or offset by the offset value. The encoder 20 may define separate modes or flags for using the DC prediction value that is equal to zero and for using the DC prediction value that is offset by the offset value. Such modes may include the Zero DC Mode and the Offset DC Mode. For the mode or flag where the DC prediction value is offset by the offset value, the encoder 20 may only code the sign of the offset value. In some embodiments, the encoder 20 derives the DC prediction value from the enhancement layer, the base layer, or a combination of the enhancement layer and the base layer. In some embodiments, the modes or flags may be signaled in a bitstream. The modes or flags may also be received in a bitstream or at least partially derived from information in a bitstream.

[00103] FIG. 5 is a flowchart illustrating an example method for defining the most probable modes for difference domain intra prediction according to aspects of this disclosure. The Most Probable Mode (MPM) list provides a list of the most probable modes for intra prediction. The MPM list generally includes three most probable modes, with the most probable mode listed first, and the least probable mode listed last. For intra prediction in non-difference domain, planar mode, DC mode, and vertical mode are generally considered to be the most probable modes and may be included in the MPM list. However, these modes may not lead to good prediction results for intra prediction in difference domain because of the high frequency nature of the difference pixels. Accordingly, the example method can determine the most probable modes for difference domain intra prediction and define the MPM list for difference domain intra prediction.

[00104] The example method will now be described in detail with reference to FIG. 5. The process 500 may be performed by an encoder (e.g., the encoder as shown in FIG. 2, etc.) or a decoder (e.g., the decoder as shown in FIG. 3, etc.). The blocks of the process 500 are described with respect to the encoder 20 in FIG. 2, but the process 500 may be performed by other components, such as a decoder, as mentioned above. At block 501, the encoder 20 determines the most probable modes for difference domain intra prediction. For example, the Zero DC Mode and the Offset DC Mode may be the most probable intra prediction modes in difference domain coding, whereas DC mode may be used rarely. In addition, angular prediction may yield better prediction results than planar mode prediction. The most probable modes may be determined based on the characteristics of the difference domain.

[00105] At block 502, the encoder 20 defines the MPM list based on the determined most probable modes for difference domain intra prediction. In the above example, the Zero DC Mode can be listed as having high probability, and DC mode can be listed as having lower probability than the Zero DC Mode. In some embodiments, a Super Most Probable Mode (MPM) may be defined. A Super MPM may take precedence over all other modes, including the modes in the MPM list. The Super MPM may precede the MPM list. In one embodiment, the Zero DC Mode may be defined as the Super MPM as follows:

- SuperMPMCand = ZERO_DC_MODE
- If (not SuperMPMCand)
 - MPM List

“SuperMPMCand” refers to the Super MPM candidate. The Zero DC Mode is set as the Super MPM. If “SuperMPMCand” is not defined, the MPM list is used.

In certain embodiments, when the Offset DC Mode is not defined, the MPM list may be defined as follows:

- **SuperMPMCand = ZERO_DC_MODE**
- **If (not SuperMPMCand)**
- intraPredModeA = intraPredModeB
 - If intraPredModeA < DC_MODE
 - **If Diff_coding_flag**
 - **candModeList[0] = Intra_Planar**
 - **candModeList[1] = Intra_Angular (26), (Vertical)**

- **candModeList[2] = Intra_Angular (10), (Horizontal)**
 - Otherwise
 - candModeList[0] = Intra_Planar
 - candModeList[1] = Intra_DC
 - candModeList[2] = Intra_Angular (26), (Vertical)
 - Otherwise,
 - candModeList[0] = candIntraPredModeA
 - candModeList[1] = $2 + ((\text{candIntraPredModeA} - 2 - 1) \% 32)$, (closest mode)
 - candModeList[2] = $2 + ((\text{candIntraPredModeA} - 2 + 1) \% 32)$, (closest mode)
- intraPredModeA != intraPredModeB
 - candModeList[0] = intraPredModeA
 - candModeList[1] = intraPredModeB
 - **If Diff_coding_flag**
 - **If intraPredModeA == Intra_Planar OR intraPredModeB == Intra_Planar**
 - **If intraPredModeA == Intra_Planar**
 - **If intraPredModeB < 18**
 - **candModeList[2] = Intra_Angular (26), (Vertical)**
 - **Otherwise**
 - **candModeList[2] = Intra_Angular (10), (Horizontal)**
 - **Otherwise**
 - **If intraPredModeA < 18**
 - **candModeList[2] = Intra_Angular (26), (Vertical)**
 - **Otherwise**
 - **candModeList[2] = Intra_Angular (10), (Horizontal)**
 - **Otherwise**
 - **candModeList[2] = Intra_Planar**
 - Otherwise
 - If intraPredModeA != Intra_Planar AND intraPredModeB != Intra_Planar
 - candModeList[2] = Intra_Planar
 - Otherwise, if intraPredModeA != Intra_DC AND intraPredModeB != Intra_DC
 - candModeList[2] = Intra_DC
 - Otherwise
 - candModeList[2] = Intra_Angular (26), (Vertical)

The portions in bold indicate differences from HEVC Working Draft 7. The term “candModeList” refers to the MPM list. The term “intraPredModeA” refers to the mode of the top neighboring Prediction Unit, and the term “intraPredModeB” refers to

the mode of the left neighboring Prediction Unit. The term “Intra_Planar” refers to planar mode; the term “Intra_DC” refers to DC mode; and “Intra_Angular” refers to an angular mode. When difference domain is used for intra prediction and the Offset DC Mode is not defined, the DC Mode may be listed as having a lower probability than other modes in the MPM list, or may not be included in the MPM list.

In other embodiments, when the Offset DC Mode is defined, the MPM list may be defined as follows:

- **SuperMPMCand = ZERO_DC_MODE**
- **If (not SuperMPMCand)**
- **intraPredModeA = intraPredModeB**
 - If **intraPredModeA < DC_MODE**
 - **If Diff_coding_flag**
 - **candModeList[0] = Intra_Planar**
 - **candModeList[1] = Intra_Offset DC**
 - **candModeList[2] = Intra_Angular (26), (Vertical)**
 - Otherwise
 - **candModeList[0] = Intra_Planar**
 - **candModeList[1] = Intra_DC**
 - **candModeList[2] = Intra_Angular (26), (Vertical)**
 - Otherwise,
 - **candModeList[0] = candIntraPredModeA**
 - **candModeList[1] = $2 + ((\text{candIntraPredModeA} - 2 - 1) \% 32)$, (closest mode)**
 - **candModeList[2] = $2 + ((\text{candIntraPredModeA} - 2 + 1) \% 32)$, (closest mode)**
- **intraPredModeA != intraPredModeB**
 - **candModeList[0] = intraPredModeA**
 - **candModeList[1] = intraPredModeB**
 - **If Diff_coding_flag**
 - If **intraPredModeA != Intra_Planar AND intraPredModeB != Intra_Planar**
 - **candModeList[2] = Intra_Planar**
 - Otherwise, if **intraPredModeA != Intra_Offset DC AND intraPredModeB != Intra_Offset DC**
 - **candModeList[2] = Intra_Offset DC**
 - Otherwise
 - **candModeList[2] = Intra_Angular (26), (Vertical)**
 - otherwise
 - If **intraPredModeA != Intra_Planar AND intraPredModeB != Intra_Planar**
 - **candModeList[2] = Intra_Planar**

- Otherwise, if $\text{intraPredModeA} \neq \text{Intra_Offset DC}$ AND $\text{intraPredModeB} \neq \text{Intra_Offset DC}$
 - $\text{candModeList}[2] = \text{Intra_Offset DC}$
- Otherwise
 - $\text{candModeList}[2] = \text{Intra_Angular (26), (Vertical)}$

The portions in bold indicate differences from HEVC Working Draft 7. The term “Intra_Offset DC” refers to the Offset DC Mode. When the Offset DC Mode is defined, DC mode is replaced with Offset DC Mode for difference domain.

[00106] In some embodiments, the modes in the MPM list may be re-ordered according to a mode’s probability of achieving optimum rate-distortion trade-off when the Zero DC Mode and/or the Offset DC Mode are used in difference domain intra prediction.

[00107] Although the example method has been described in terms of pixels, the example method described with respect to FIG. 5 may be implemented at various syntax levels. In addition, all embodiments described with respect to FIG. 5 may be implemented separately, or in combination with one another.

[00108] FIG. 5A is a flowchart illustrating another example method for determining the most probable modes for difference domain intra prediction according to aspects of this disclosure. The process 500A may be performed by an encoder (e.g., the encoder as shown in FIG. 2, etc.) or a decoder (e.g., the decoder as shown in FIG. 3, etc.). The blocks of the process 500A are described with respect to the encoder 20 in FIG. 2, but the process 500A may be performed by other components, such as a decoder, as mentioned above. All embodiments described with respect to FIG. 5A may be implemented separately, or in combination with one another.

[00109] At block 501A, the encoder 20 determines a Most Probable Mode (MPM) list associated with the difference video layer based on characteristics of the difference video layer. The difference video layer may refer to the difference domain. An MPM list may include a number of most probable modes in determining the value of a video unit. In some embodiments, the MPM list includes three most probable modes. Some characteristics of the difference video layer may be that DC prediction may not lead to good prediction results.

[00110] At block 502A, the encoder 20 determines a value of a video unit based on the difference video layer and the MPM list. A video unit may be any unit of video data, and can include but is not limited to: a frame, a slice, a largest coding unit (LCU),

a coding unit (CU), a block, a pixel, and a sub-pixel. The value of the video unit may be determined by generating a prediction unit (PU) for the video unit.

[00111] In some embodiments, the MPM list associated with the difference video layer includes a mode in which a DC prediction value is equal to zero or is adjusted by an offset value, and the DC prediction value is determined while refraining from using pixel information from a neighboring area of the video unit. The DC prediction value may be a prediction value used in intra prediction based on an average of neighboring video units of the video unit. The mode in which the DC prediction value is equal to zero or is adjusted by the offset value may include the Zero DC Mode and/or the Offset DC Mode.

[00112] In some embodiments, the encoder 20 determines a Super Most Probable Mode (MPM) that includes the mode in which the DC prediction value is equal to zero or is adjusted by the offset value. For example, the Super MPM can include the Zero DC Mode and/or the Offset DC Mode. A Super MPM may take precedence over modes in the MPM list in determining the value of the video unit. The encoder 20 may determine both a Super MPM and the MPM list for determining the value of the video unit. In one embodiment, the Super MPM could be the mode in which the DC prediction value is equal to zero, and the MPM list could include the mode in which the DC prediction value is adjusted by the offset value. Both the Super MPM and the MPM list could be signaled in a bitstream. Both the Super MPM and the MPM list may also be received in a bistream, or at least partially derived from information in a bitstream.

[00113] In some embodiments, the MPM list associated with the difference video layer is re-ordered according to a probability of achieving an optimum rate-distortion trade-off when the mode in which the DC prediction value is equal to zero or is adjusted by the offset value.

[00114] In some embodiments, a DC prediction mode in the MPM list is replaced by the mode in which the DC prediction is adjusted by the offset value when the video unit value is determined based on the difference video layer. The DC prediction mode may be an intra prediction mode based at least in part on an average of neighboring video units of the video unit. In some embodiments, the DC prediction mode may be the DC mode. In some embodiments, the DC prediction mode has a lower probability than other modes in the MPM list or is not included in the MPM list.

[00115] FIG. 6 illustrates a flowchart illustrating an example method for coding an enhancement layer in intra prediction mode according to aspects of this disclosure.

The process 600 may be performed by an encoder (e.g., the encoder as shown in FIG. 2, etc.) or a decoder (e.g., the decoder as shown in FIG. 3, etc.). The example method may modify the coding of an enhancement layer in intra prediction mode to add syntax elements to code the DC extension modes illustrated in FIGS. 4A and 4B (the Zero DC Mode and the DC Offset Mode). Additional elements may be added to the syntax to indicate the following information: 1) whether difference domain is used for intra prediction; 2) whether Zero DC Mode is used for difference domain intra prediction; 3) the DC offset sign if DC Offset Mode is used for luma prediction; and 4) the DC offset sign if DC Offset Mode is used for chroma prediction.

[00116] In addition, the example method may modify the coding order of syntax elements in order to make the coding process faster and more efficient. For example, the indication of whether the difference domain is used for intra prediction is coded in an earlier portion of the syntax. In difference domain coding, the Zero DC Mode and the DC Offset Mode are likely to be more frequent. Thus, if the indication about whether difference domain is used for intra prediction can be conveyed early on in the syntax, the indication that the Zero DC Mode and the DC Offset Mode can also be conveyed early in the coding sequence. This would make the coding process for DC prediction in difference domain faster.

[00117] The example method for coding an enhancement layer in intra prediction mode according to aspects of this disclosure will now be explained in detail with reference to FIG. 6. The blocks of the process 600 are described with respect to the encoder 20 in FIG. 2, but the process 600 may be performed by other components, such as a decoder, as mentioned above.

[00118] At block 601, if the slice type is intra, the encoder 20 codes whether intra prediction is performed in the difference domain at block 602. The process 600 then continues to block 604. If the slice type is not intra at block 601, the encoder 20 sets the intra prediction domain as the difference domain at block 603. After block 603, the encoder 20 may not perform any further processing. When the slice type is not intra, the indication regarding whether the difference domain is used for intra prediction is not coded, but rather set as the default mode. The default mode may be assumed for non-intra slices because the probability of using pixel domain on non-intra slices for intra prediction is very low.

[00119] At block 604, if the difference domain is used for intra prediction, the encoder 20 codes whether the Zero DC Mode is used for the intra prediction at block

605. If the difference domain is not used for intra prediction at block 604, the encoder 20 sets the intra prediction mode as not Zero DC Mode at block 606. After block 603, the encoder 20 may not perform any further processing. For example, when difference domain is not used for intra prediction, the indication regarding whether the Zero DC Mode is used for intra prediction is not coded, but not using the Zero DC Mode is set as the default mode. The not Zero DC Mode may be assumed for non-difference domain coding because the Zero DC Mode is not very likely to be used in pixel domain intra prediction.

[00120] At block 607, if the DC Offset Mode is used for luma prediction, the encoder 20 codes the DC luma offset sign at block 608. In the DC Offset Mode, an offset value sign is signaled in the bitstream, and an offset value of either 1 or -1 may be added to the DC value. The DC luma offset sign indicates whether the sign of this offset value is plus 1 or minus 1. At block 607, if the DC Offset Mode is not used for luma prediction, the encoder 20 may not perform any further processing.

[00121] At block 609, if the DC Offset Mode is used for chroma prediction, the encoder 20 codes the DC chroma offset sign at block 610. The DC chroma offset sign may indicate whether the sign of the offset value is plus 1 or minus 1. At block 609, if the DC Offset Mode is not used for chroma prediction, the encoder 20 may not perform any further processing.

[00122] In one embodiment, the syntax elements added to code the Zero DC Mode and the DC Offset Mode may be defined as follows:

- `diff_coding_flag[x0][y0]`: specifies that intra prediction is performed in difference domain. For non-intra slices, the intra prediction mode is always set to difference domain.
- `Zero_DC_Pred_Flag[x0][y0]`: specifies whether the current Partition Unit is coded as `ZERO_DC_MODE` or not. When the value of this syntax element is equal to 1, `intra_Luma_pred_mode[x0][y0]` and `intra_Chroma_pred_mode[x0][y0]` elements are set to Zero DC Mode. This element may be context coded.
- `DC_LumaOffset_Sign[x0][y0]`: specifies the `DC_LumaOffset_Sign` when `intra_Luma_pred_mode[x0][y0]` is DC Offset Mode.
- `DC_ChromaOffset_Sign[x0][y0]`: specifies the `DC_LumaOffset_Sign` when `intra_Chroma_pred_mode[x0][y0]` is DC Offset Mode. When `chroma_pred_from_luma_enabled_flag` is signaled, the `DC_ChromaOffset_Sign[x0][y0]` is derived from

DC_LumaOffset_Sign[x0][y0].

Further, the syntax for coding the enhancement layer may be defined as follows:

if (slice_type != I)
diff_coding_flag[x0][y0] = 1
else
diff_coding_flag[x0][y0]
if (diff_coding_flag[x0][y0])
Zero_DC_Pred_Flag[x0][y0]
else
Zero_DC_Pred_Flag[x0][y0] = 0
if (Zero_DC_Pred_Flag[x0][y0] == 0)
{
prev_intra_luma_pred_flag[x0][y0]
if (prev_intra_luma_pred_flag[x0][y0])
mpm_idx[x0][y0]
else
rem_intra_luma_pred_mode[x0][y0]
if (intra_Luma_pred_mode[x0][y0] == DC_OFFSET && diff_coding_flag[x0][y0])
DC_LumaOffset_Sign[x0][y0]:
intra_chroma_pred_mode[x0][y0]
SignalledAsChromaDC =
(chroma_pred_from_luma_enabled_flag ?
intra_chroma_pred_mode[x0][y0] == 3:
intra_chroma_pred_mode[x0][y0] == 2)
if (intra_chroma_pred_mode[x0][y0] == DC_OFFSET &&
diff_coding_flag[x0][y0])
DC_ChromaOffset_Sign[x0][y0]:
}

Table 1 – Example Syntax for Difference Domain Coding

[00123] Although the example method has been described in terms of pixels, the example method described with respect to FIG. 6 may be implemented at various syntax levels. In addition, all embodiments described with respect to FIG. 6 may be implemented separately, or in combination with one another.

[00124] FIG. 7 is a flowchart illustrating an example method for coding information regarding whether residual data exists according to aspects of this disclosure. The process 700 may be performed by an encoder (e.g., the encoder as

shown in FIG. 2, etc.) or a decoder (e.g., the decoder as shown in FIG. 3, etc.). Because the difference domain may include many high frequency components, performing a transform tree, such as DCT, and residue coding on the difference domain pixels may lead to poor rate-distortion trade-off. Accordingly, it may be desirable to bypass or skip the transform tree and residual coding process in difference domain intra prediction. Such bypass can be accomplished by indicating that no residual data exists with respect to a CU. The example method may code the no residual data information for each block in the difference domain if performing a transform will lead to poor rate distortion trade-off.

[00125] The example method for coding information regarding whether residual data exists according to aspects of this disclosure will now be explained in detail with reference to FIG. 7. The blocks of the process 700 are described with respect to the encoder 20 in FIG. 2, but the process 700 may be performed by other components, such as a decoder, as mentioned above. At block 701, the encoder 20 determines whether to bypass the transform tree and residual coding process. For example, the encoder 20 may determine if performing a transform tree and residual coding will result in a better rate-distortion trade-off. The encoder 20 may also choose to skip transform tree and residual coding as the default. At block 702, the encoder 20 codes one or more syntax elements for bypassing transform tree and residual coding. For example, the encoder 20 may specify whether residual data exists in order to indicate transform skip.

[00126] In one embodiment, the indication of whether residual data exists is coded using the “no_residual_data_flag” in HEVC. The “no_residual_data_flag” may be coded in the enhancement layer when the difference domain is being used for intra prediction. In one embodiment, the condition for coding the “no_residual_data_flag” may be expressed as “if (trafoDepth == 0 && IntraSplitFlag == 0 && PredMode != MODE_INTRA && !(PartMode == PART_2Nx2N && merge_flag[x0][y0]) || ((PredMode == MODE_INTRA) && diff_coding_flag)).” In HEVC Working Draft 7, the “no_residual_data_flag” is coded when the condition “if (trafoDepth == 0 && IntraSplitFlag == 0 && PredMode != MODE_INTRA && !(PartMode == PART_2Nx2N && merge_flag[x0][y0]))” is met. The term “trafoDepth” refers to transform depth. The term “PartMode” refers to the partitioning mode of the current coding unit (e.g., 2Nx2N, NxN, etc.). The term “PredMode” refers to the prediction mode (e.g., intra, inter, skip prediction mode, etc.). The term “IntraSplitFlag” refers to the current transform coding depth for intra coding units. The term “merge_flag”

indicates whether the current inter prediction unit is using merge prediction. The portion added in the condition for difference domain (in bold) instructs the encoder 20 to code the “no_residual_data_flag” when difference domain intra prediction is being performed.

[00127] In another embodiment, the condition for coding the “no_residual_data_flag” may be expressed as “if (trafoDepth == 0 && IntraSplitFlag == 0 && PredMode != MODE_INTRA && !(PartMode == PART_2Nx2N && merge_flag[x0][y0]) || **((PartMode == PART_2Nx2N && diff_coding_flag && ! merge_flag[x0][y0]))**.” The portion added in the condition (in bold) enables the “no_residual_data_flag” to be extended to both intra or inter when difference domain coding is selected.

[00128] The example method described with respect to FIG. 7 may be implemented at various syntax levels. In addition, all embodiments described with respect to FIG. 7 may be implemented separately, or in combination with one another.

[00129] FIG. 7A is a flowchart illustrating another example method for bypassing transform tree and residual coding in difference domain according to aspects of this disclosure. The process 700A may be performed by an encoder (e.g., the encoder as shown in FIG. 2, etc.) or a decoder (e.g., the decoder as shown in FIG. 3, etc.). The blocks of the process 700A are described with respect to the encoder 20 in FIG. 2, but the process 700A may be performed by other components, such as a decoder, as mentioned above. All embodiments described with respect to FIG. 7A may be implemented separately, or in combination with one another.

[00130] At block 701A, the encoder 20 determines a value of a video unit based on the difference video layer. The difference video layer may refer to the difference domain. A video unit may be any unit of video data, and can include but is not limited to: a frame, a slice, a largest coding unit (LCU), a coding unit (CU), a block, a pixel, and a sub-pixel. The value of the video unit may be determined by generating a prediction unit (PU) for the video unit.

[00131] At block 702A, the encoder 20 refrains from performing a transform and residual coding of the determined value of the video unit. The encoder 20 may choose not to code the transform tree and residue, e.g., when the difference video layer is used to determine the value of the video unit. When using the difference video layer, performing the transform and residual coding for the video unit may lead to poor rate-distortion trade-off. Accordingly, the encoder 20 may choose to not perform the

transform and residual coding whenever the video unit relates to the difference domain layer, or on a case-by-case basis for each video unit. In some embodiments, refraining from performing the transform and residual coding can be indicated by whether residual data exists for the video unit. In one embodiment, such information is indicated using the “no_residual_data_flag” in HEVC.

[00132] In some embodiments, the encoder 20 refrains from performing the transform and residual coding of the determined value of the video unit when the video unit is associated with the difference video layer. In some embodiments, the encoder 20 refrains from performing the transform and residual coding of the determined value of the video unit based at least in part on a rate-distortion cost of performing the transform and residual coding. In some embodiments, the encoder 20 codes the video information based upon a plurality of syntax elements, and the encoder 20 refrains from performing the transform and residual coding of the determined value of the video unit when corresponding one or more syntax elements indicate that the transform and residual coding should not be performed. In one embodiment, the one or more syntax elements include a flag that indicates whether residual data exists for the video unit. The flag may be signaled in a bitstream. The flag may be received in a bitstream, or at least partially derived from information in a bitstream.

[00133] It is to be recognized that depending on the example, certain acts or events of any of the techniques described herein can be performed in a different sequence, may be added, merged, or left out altogether (e.g., not all described acts or events are necessary for the practice of the techniques). Moreover, in certain examples, acts or events may be performed concurrently, e.g., through multi-threaded processing, interrupt processing, or multiple processors, rather than sequentially.

[00134] In one or more examples, the functions described may be implemented in hardware, software, firmware, or any combination thereof. If implemented in software, the functions may be stored on or transmitted over as one or more instructions or code on a computer-readable medium and executed by a hardware-based processing unit. Computer-readable media may include computer-readable storage media, which corresponds to a tangible medium such as data storage media, or communication media including any medium that facilitates transfer of a computer program from one place to another, e.g., according to a communication protocol. In this manner, computer-readable media generally may correspond to (1) tangible computer-readable storage media which is non-transitory or (2) a communication medium such as a signal or

carrier wave. Data storage media may be any available media that can be accessed by one or more computers or one or more processors to retrieve instructions, code and/or data structures for implementation of the techniques described in this disclosure. A computer program product may include a computer-readable medium.

[00135] By way of example, and not limitation, such computer-readable storage media can comprise RAM, ROM, EEPROM, CD-ROM or other optical disk storage, magnetic disk storage, or other magnetic storage devices, flash memory, or any other medium that can be used to store desired program code in the form of instructions or data structures and that can be accessed by a computer. Also, any connection is properly termed a computer-readable medium. For example, if instructions are transmitted from a website, server, or other remote source using a coaxial cable, fiber optic cable, twisted pair, digital subscriber line (DSL), or wireless technologies such as infrared, radio, and microwave, then the coaxial cable, fiber optic cable, twisted pair, DSL, or wireless technologies such as infrared, radio, and microwave are included in the definition of medium. It should be understood, however, that computer-readable storage media and data storage media do not include connections, carrier waves, signals, or other transitory media, but are instead directed to non-transitory, tangible storage media. Disk and disc, as used herein, includes compact disc (CD), laser disc, optical disc, digital versatile disc (DVD), floppy disk and Blu-ray disc, where disks usually reproduce data magnetically, while discs reproduce data optically with lasers. Combinations of the above should also be included within the scope of computer-readable media.

[00136] Instructions may be executed by one or more processors, such as one or more digital signal processors (DSPs), general purpose microprocessors, application specific integrated circuits (ASICs), field programmable logic arrays (FPGAs), or other equivalent integrated or discrete logic circuitry. Accordingly, the term “processor,” as used herein may refer to any of the foregoing structure or any other structure suitable for implementation of the techniques described herein. In addition, in some aspects, the functionality described herein may be provided within dedicated hardware and/or software modules configured for encoding and decoding, or incorporated in a combined codec. Also, the techniques could be fully implemented in one or more circuits or logic elements.

[00137] The techniques of this disclosure may be implemented in a wide variety of devices or apparatuses, including a wireless handset, an integrated circuit (IC) or a set

of ICs (e.g., a chip set). Various components, modules, or units are described in this disclosure to emphasize functional aspects of devices configured to perform the disclosed techniques, but do not necessarily require realization by different hardware units. Rather, as described above, various units may be combined in a codec hardware unit or provided by a collection of interoperative hardware units, including one or more processors as described above, in conjunction with suitable software and/or firmware.

[00138] Various examples have been described. These and other examples are within the scope of the following claims.

WHAT IS CLAIMED IS:

1. An apparatus configured to code video information, the apparatus comprising:
 - a memory unit configured to store difference video information associated with a difference video layer of pixel information derived from a difference between an enhancement layer and a corresponding base layer of the video information; and
 - a processor in communication with the memory unit, the processor configured to determine a value of a video unit based on the difference video layer, wherein the processor is further configured to refrain from performing a transform and residual coding of the determined value of the video unit.
2. The apparatus of claim 1, wherein the processor is configured to refrain from performing the transform and residual coding of the determined value of the video unit when the video unit is associated with the difference video layer.
3. The apparatus of claim 1, wherein the processor is configured to refrain from performing the transform and residual coding of the determined value of the video unit based at least in part on a rate-distortion cost of performing the transform and residual coding.
4. The apparatus of claim 1, wherein the processor is further configured to encode one or more corresponding syntax elements that indicate that the transform and residual coding should not be performed.
5. The apparatus of claim 4, wherein the one or more syntax elements comprise a flag that indicates whether residual data exists for the video unit.
6. The apparatus of claim 5, wherein the processor is further configured to signal the flag in a bitstream and to encode the video unit.
7. The apparatus of claim 1, wherein the processor is further configured to decode the video information based upon a plurality of syntax elements, wherein the processor

is configured to refrain from performing the transform and residual coding of the determined value of the video unit when one or more corresponding syntax elements indicate that the transform and residual coding should not be performed.

8. The apparatus of claim 7, wherein the one or more syntax elements comprise a flag that indicates whether residual data exists for the video unit.

9. The apparatus of claim 8, wherein the processor is further configured to receive the flag in a bitstream or at least partially derive the flag from information in a bitstream, and to decode the video unit.

10. The apparatus of claim 7, wherein the one or more syntax elements indicate that no residual data exists for the video unit.

11. The apparatus of claim 10, wherein the one or more syntax elements indicate that no residual data exists for the video unit when intra prediction is performed using the difference video layer.

12. The apparatus of claim 1, wherein determining the value of the video unit is based at least in part on a DC prediction value that is equal to zero or is adjusted by an offset value, wherein the DC prediction value is a prediction value used in intra prediction based on an average of neighboring video units of the video unit.

13. The apparatus of claim 1, wherein the video unit is selected from a group comprising: frame, slice, largest coding unit (LCU), coding unit (CU), block, pixel, and sub-pixel.

14. The apparatus of claim 1, wherein the processor is further configured to determine the video unit value by generating a prediction unit for the video unit.

15. The apparatus of claim 1, wherein the base layer is a reconstructed base layer.

16. The apparatus of claim 1, wherein the apparatus is selected from a group consisting of one or more of: a desktop computer, a notebook computer, a laptop

computer, a tablet computer, a set-top box, a telephone handset, a smart phone, a smart pad, a television, a camera, a display device, a digital media player, a video gaming console, and a video streaming device.

17. A method of coding video information comprising:

storing difference video information associated with a difference video layer of pixel information derived from a difference between an enhancement layer and a corresponding base layer of the video information;

determining a value of a video unit based on the difference video layer;

and

refraining from performing a transform and residual coding of the determined value of the video unit.

18. The method of claim 17, further comprising refraining from performing the transform and residual coding of the determined value of the video unit when the video unit is associated with the difference video layer.

19. The method of claim 17, further comprising refraining from performing the transform and residual coding of the determined value of the video unit based at least in part on a rate-distortion cost of performing the transform and residual coding.

20. The method of claim 17, further comprising encoding one or more corresponding syntax elements that indicate that the transform and residual coding should not be performed.

21. The method of claim 20, wherein the one or more syntax elements comprise a flag that indicates whether residual data exists for the video unit.

22. The method of claim 21, further comprising signaling the flag in a bitstream and encoding the video unit.

23. The method of claim 17, further comprising decoding the video information based upon a plurality of syntax elements, refraining from performing the transform and

residual coding of the determined value of the video unit when one or more corresponding syntax elements indicate that the transform and residual coding should not be performed.

24. The method of claim 23, wherein the one or more syntax elements comprise a flag that indicates whether residual data exists for the video unit.

25. The method of claim 24, further comprising receiving the flag in a bitstream or at least partially deriving the flag from information in a bitstream, and decoding the video unit.

26. The method of claim 23, wherein the one or more syntax elements indicate that no residual data exists for the video unit.

27. The method of claim 26, wherein the one or more syntax elements indicate that no residual data exists for the video unit when intra prediction is performed using the difference video layer.

28. The method of claim 17, wherein determining the value of the video unit is based at least in part on a DC prediction value that is equal to zero or is adjusted by an offset value, wherein the DC prediction value is a prediction value used in intra prediction based on an average of neighboring video units of the video unit.

29. The method of claim 17, wherein the video unit is selected from a group comprising: frame, slice, largest coding unit (LCU), coding unit (CU), block, pixel, and sub-pixel.

30. The method of claim 17, further comprising determining the video unit value by generating a prediction unit for the video unit.

31. The method of claim 17, wherein the base layer is a reconstructed base layer.

32. A computer-readable storage medium having instructions stored thereon that when executed cause an apparatus to:

store difference video information associated with a difference video layer of pixel information derived from a difference between an enhancement layer and a corresponding base layer of the video information;

determine a value of a video unit based on the difference video layer; and

refrain from performing a transform and residual coding of the determined value of the video unit.

33. The computer-readable storage medium of claim 32, further comprising instructions to refrain from performing the transform and residual coding of the determined value of the video unit when the video unit is associated with the difference video layer.

34. The computer-readable storage medium of claim 32, further comprising instructions to refrain from performing the transform and residual coding of the determined value of the video unit based at least in part on a rate-distortion cost of performing the transform and residual coding.

35. The computer-readable storage medium of claim 32, further comprising instructions to encode one or more corresponding syntax elements that indicate that the transform and residual coding should not be performed.

36. The computer-readable storage medium of claim 32, further comprising instructions to decode the video information based upon a plurality of syntax elements, wherein the processor is configured to refrain from performing the transform and residual coding of the determined value of the video unit when one or more corresponding syntax elements indicate that the transform and residual coding should not be performed.

37. The computer-readable storage medium of claim 36, wherein the one or more syntax elements comprise a flag that indicates whether residual data exists for the video unit.

38. The computer-readable storage medium of claim 36, wherein the one or more syntax elements indicate that no residual data exists for the video unit.

39. The computer-readable storage medium of claim 38, wherein the one or more syntax elements indicate that no residual data exists for the video unit when intra prediction is performed using the difference video layer.

40. The computer-readable storage medium of claim 32, wherein determining the value of the video unit is based at least in part on a DC prediction value that is equal to zero or is adjusted by an offset value, wherein the DC prediction value is a prediction value used in intra prediction based on an average of neighboring video units of the video unit.

41. An apparatus configured to code video information, the apparatus comprising:
means for storing difference video information associated with a difference video layer of pixel information derived from a difference between an enhancement layer and a corresponding base layer of the video information; and
means for determining a value of a video unit based on the difference video layer, the means for determining the value of the video unit refraining from performing a transform and residual coding of the determined value of the video unit.

42. The apparatus of claim 41, wherein the means for determining the value of the video unit is configured to refrain from performing the transform and residual coding of the determined value of the video unit when the video unit is associated with the difference video layer.

43. The apparatus of claim 41, wherein the means for determining the value of the video unit is configured to refrain from performing the transform and residual coding of the determined value of the video unit based at least in part on a rate-distortion cost of performing the transform and residual coding.

44. The apparatus of claim 41, wherein the means for determining the value of the video unit is further configured to encode one or more corresponding syntax elements that indicate that the transform and residual coding should not be performed.

45. The apparatus of claim 41, wherein the means for determining the value of the video unit is further configured to decode the video information based upon a plurality of syntax elements, wherein the processor is configured to refrain from performing the transform and residual coding of the determined value of the video unit when one or more corresponding syntax elements indicate that the transform and residual coding should not be performed.

46. The apparatus of claim 45, wherein the one or more syntax elements comprise a flag that indicates whether residual data exists for the video unit.

47. The apparatus of claim 45, wherein the one or more syntax elements indicate that no residual data exists for the video unit.

48. The apparatus of claim 47, wherein the one or more syntax elements indicate that no residual data exists for the video unit when intra prediction is performed using the difference video layer.

49. The apparatus of claim 41, wherein determining the value of the video unit is based at least in part on a DC prediction value that is equal to zero or is adjusted by an offset value, wherein the DC prediction value is a prediction value used in intra prediction based on an average of neighboring video units of the video unit.

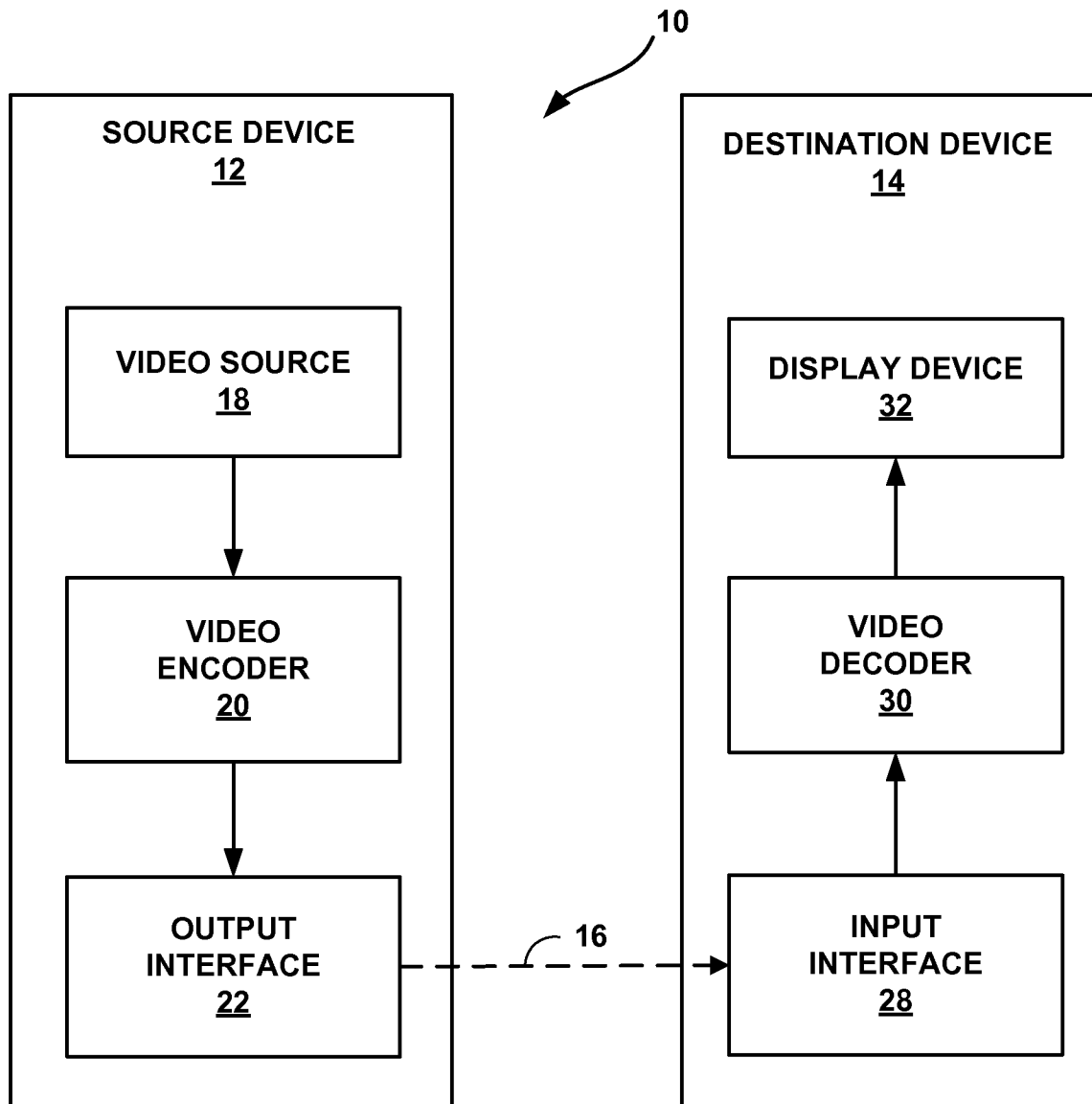

FIG. 1

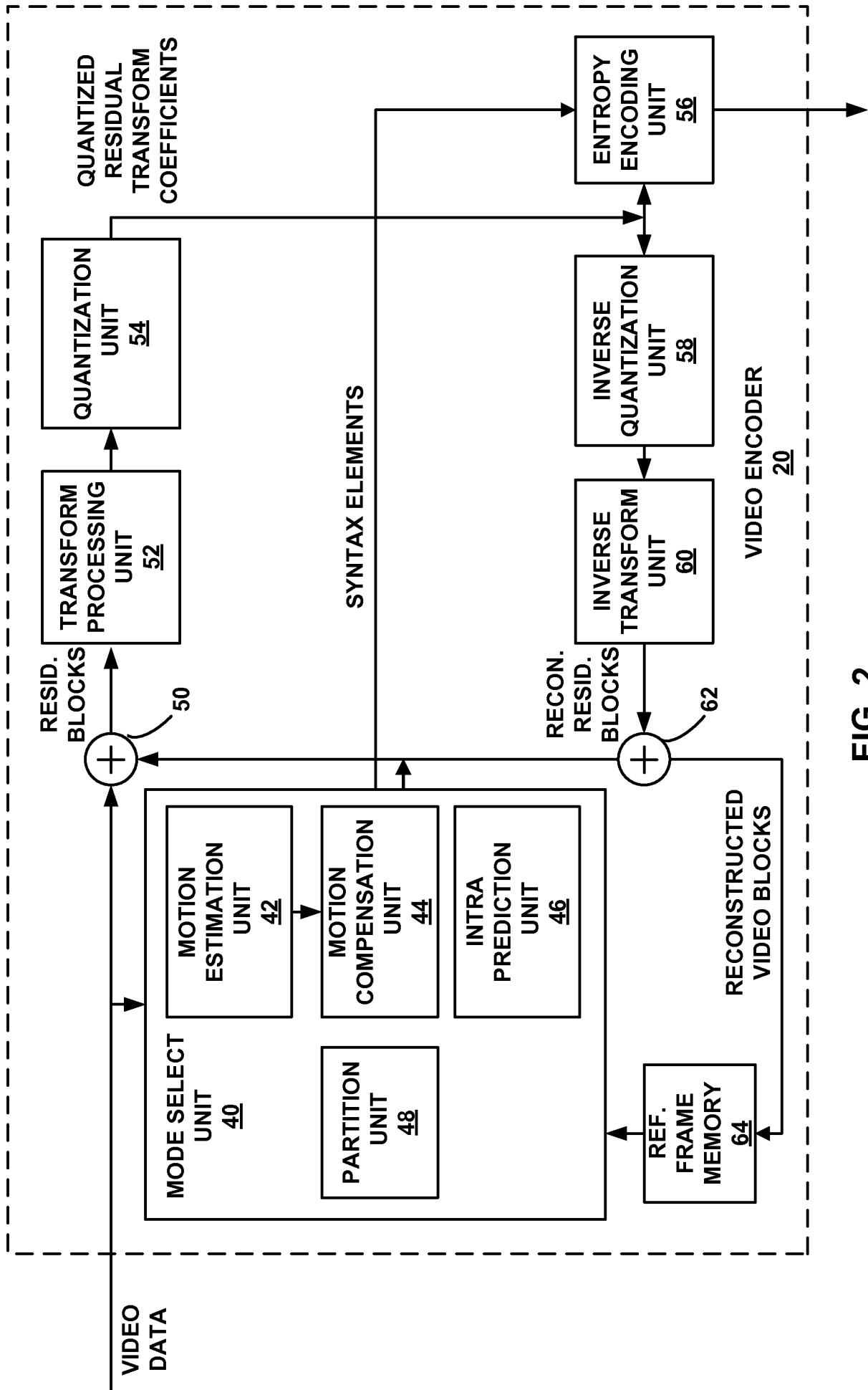

FIG. 2

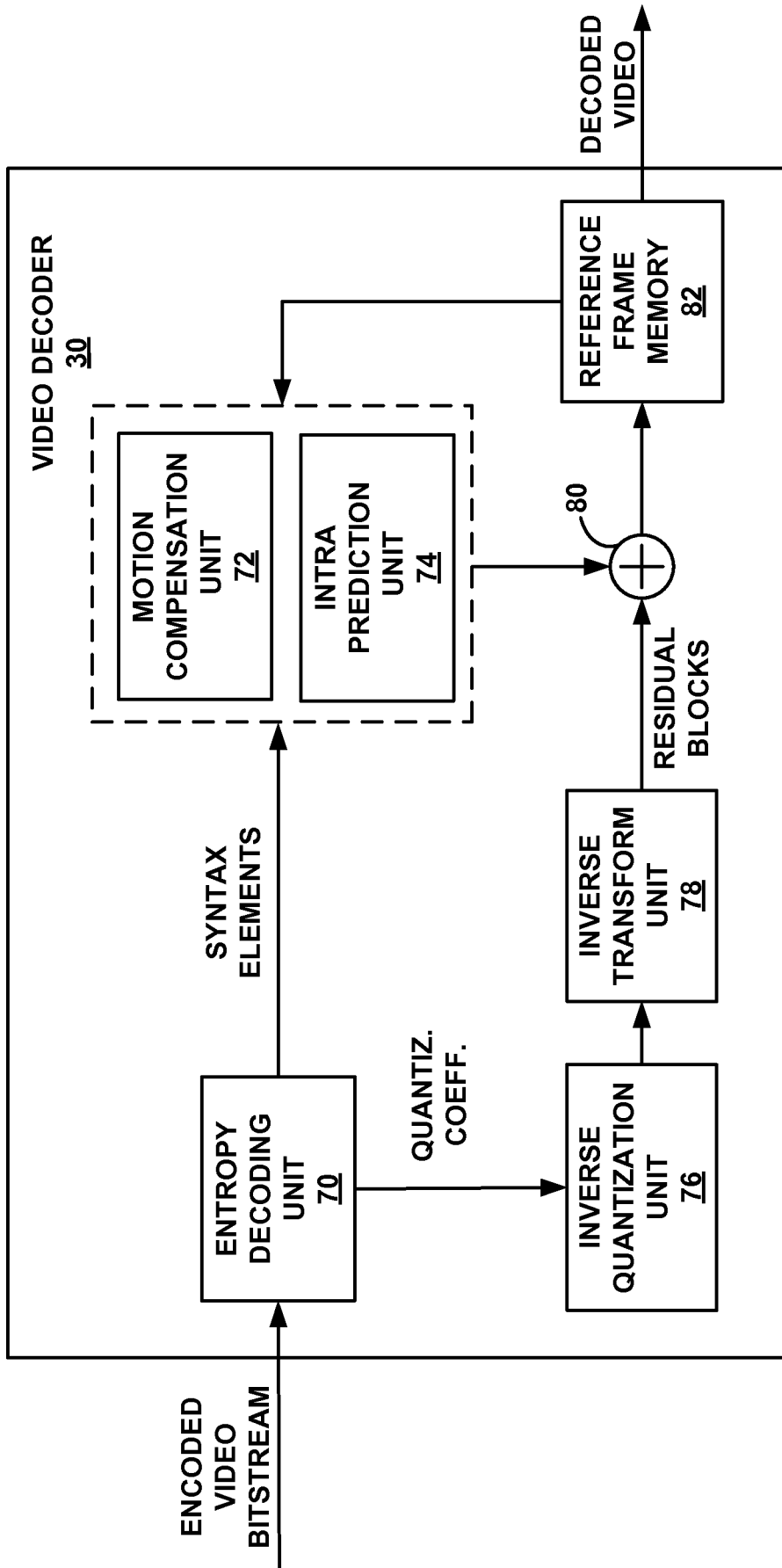

FIG. 3

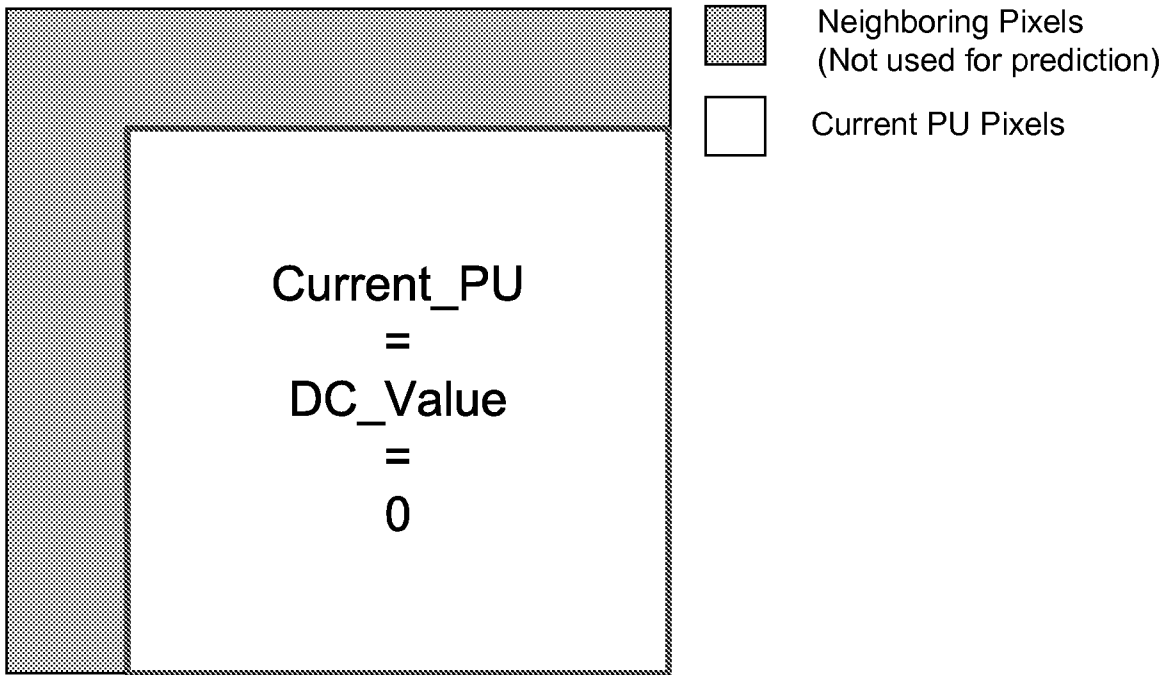

FIG. 4A

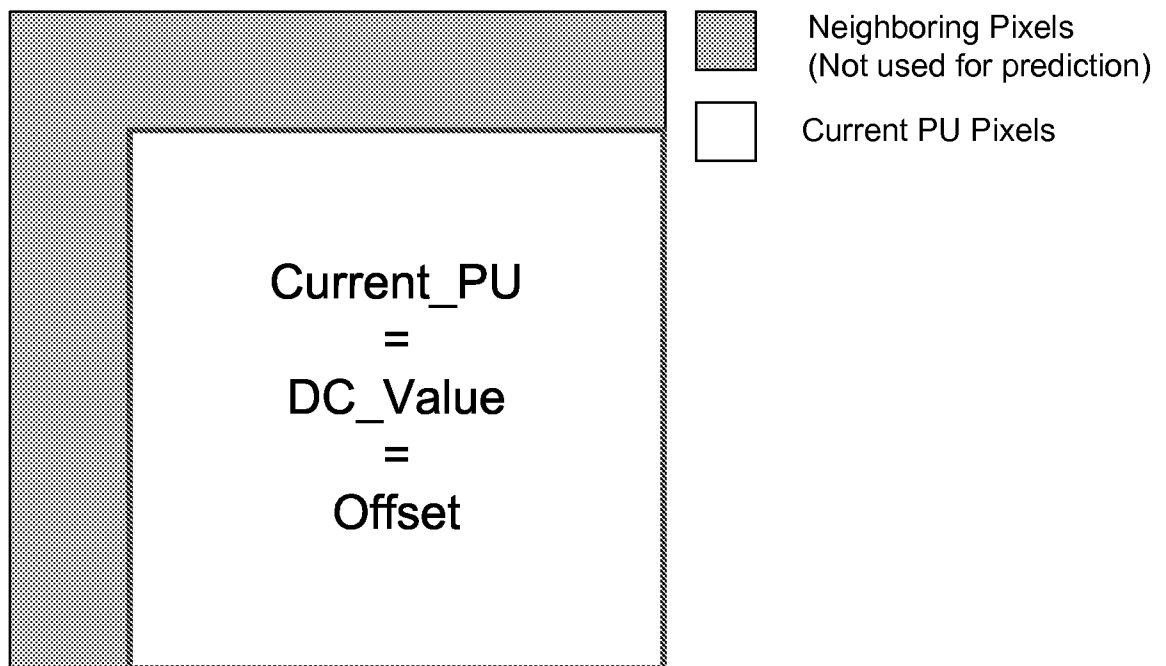

FIG. 4B

5 / 10

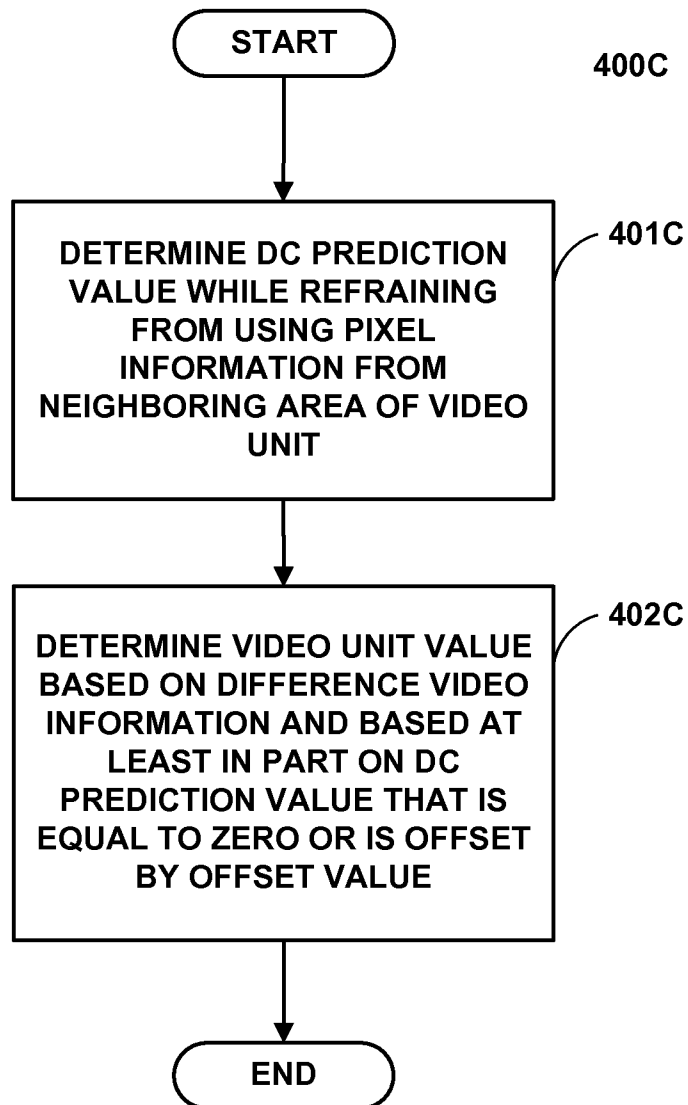

FIG. 4C

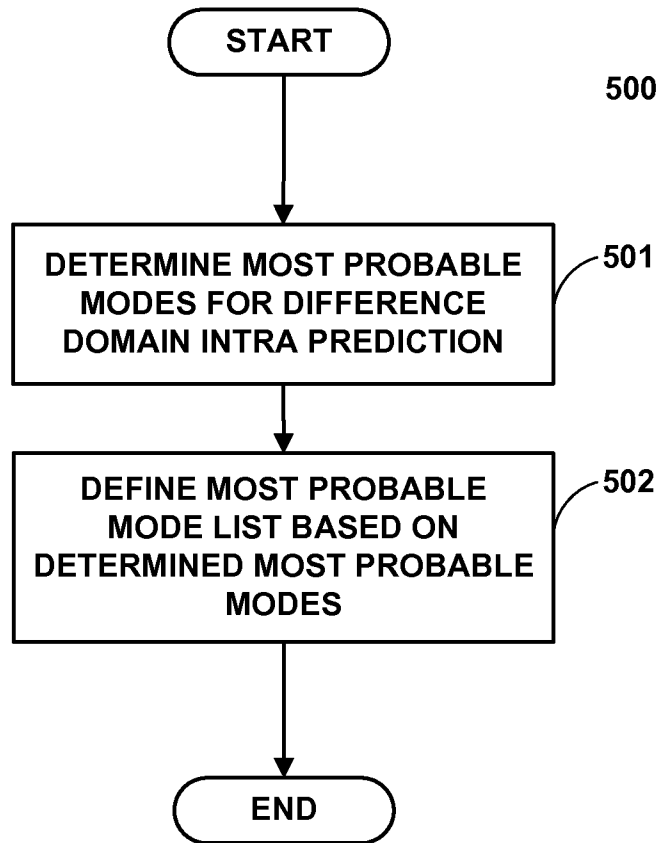

FIG. 5

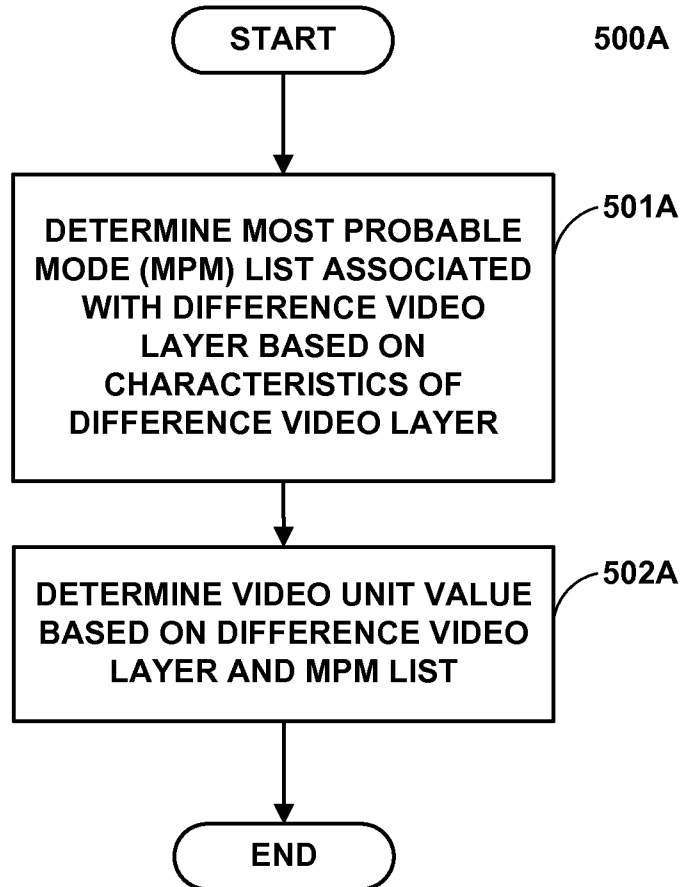

FIG. 5A

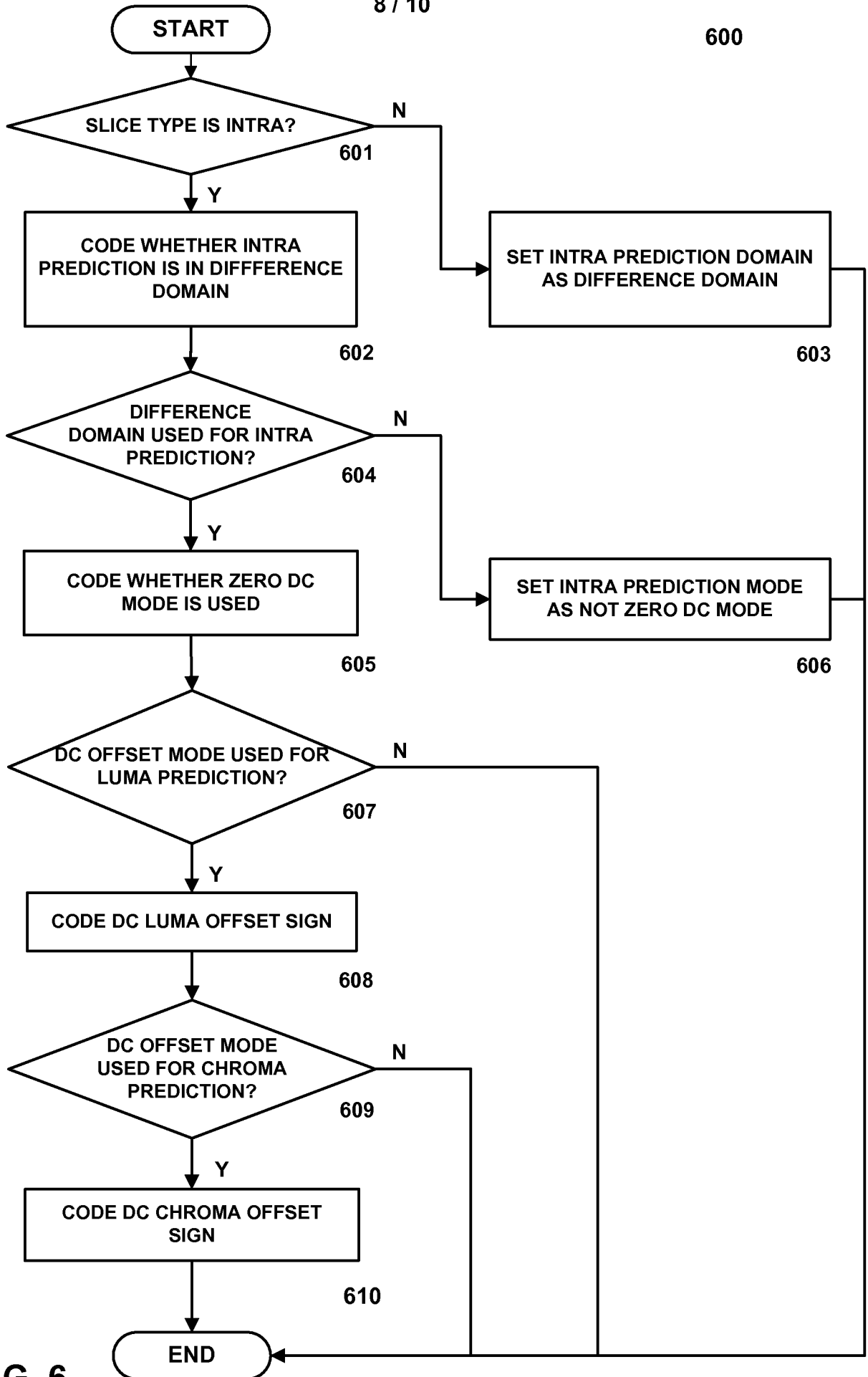

FIG. 6

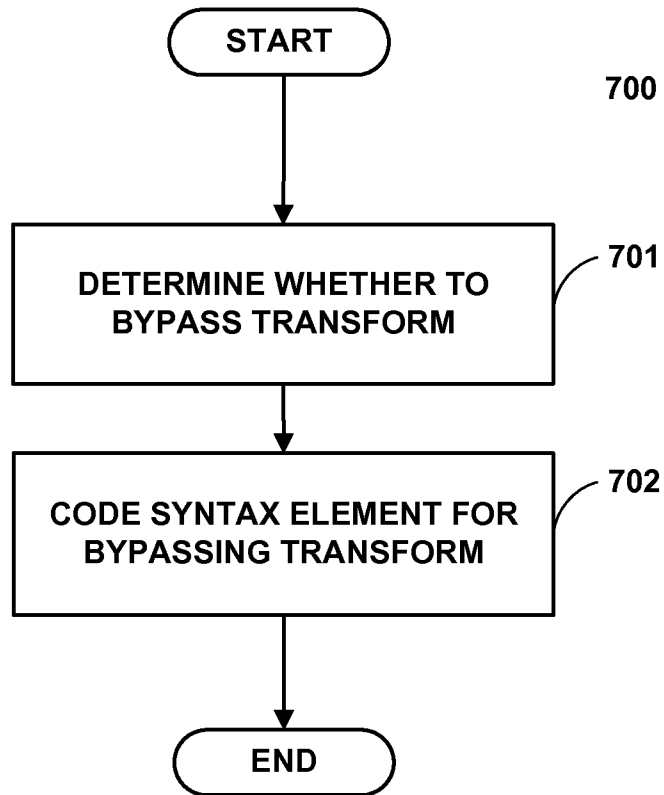

FIG. 7

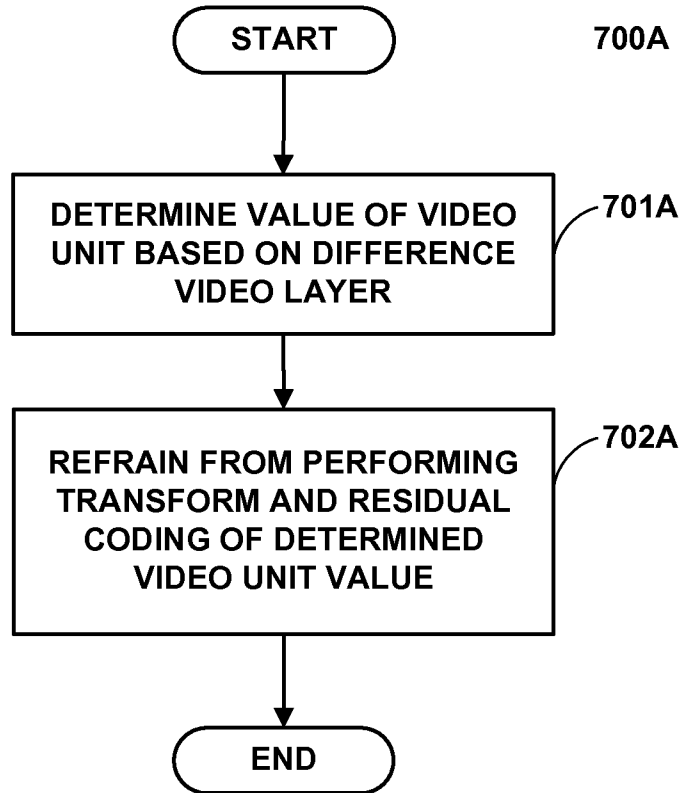

FIG. 7A

INTERNATIONAL SEARCH REPORT

International application No
PCT/US2013/049472

A. CLASSIFICATION OF SUBJECT MATTER
INV. H04N7/26 H04N7/34
ADD.
According to International Patent Classification (IPC) or to both national classification and IPC

B. FIELDS SEARCHED
Minimum documentation searched (classification system followed by classification symbols)
H04N

Documentation searched other than minimum documentation to the extent that such documents are included in the fields searched

Electronic data base consulted during the international search (name of data base and, where practicable, search terms used)
EPO-Internal, COMPENDEX, INSPEC, WPI Data, IBM-TDB

C. DOCUMENTS CONSIDERED TO BE RELEVANT

Category*	Citation of document, with indication, where appropriate, of the relevant passages	Relevant to claim No.
X	HONG D ET AL: "Scalability Support in HEVC", 97. MPEG MEETING; 18-7-2011 - 22-7-2011; TORINO; (MOTION PICTURE EXPERT GROUP OR ISO/IEC JTC1/SC29/WG11),, no. m20710, 13 July 2011 (2011-07-13), XP030049273,	1-11, 13-27, 29-39, 41-48
Y	section [2.1 Support for difference coding mode]; the whole document ----- -/--	12,28, 40,49

Further documents are listed in the continuation of Box C.

See patent family annex.

* Special categories of cited documents :

- "A" document defining the general state of the art which is not considered to be of particular relevance
- "E" earlier application or patent but published on or after the international filing date
- "L" document which may throw doubts on priority claim(s) or which is cited to establish the publication date of another citation or other special reason (as specified)
- "O" document referring to an oral disclosure, use, exhibition or other means
- "P" document published prior to the international filing date but later than the priority date claimed

- "T" later document published after the international filing date or priority date and not in conflict with the application but cited to understand the principle or theory underlying the invention
- "X" document of particular relevance; the claimed invention cannot be considered novel or cannot be considered to involve an inventive step when the document is taken alone
- "Y" document of particular relevance; the claimed invention cannot be considered to involve an inventive step when the document is combined with one or more other such documents, such combination being obvious to a person skilled in the art
- "&" document member of the same patent family

Date of the actual completion of the international search 10 October 2013	Date of mailing of the international search report 16/10/2013
Name and mailing address of the ISA/ European Patent Office, P.B. 5818 Patentlaan 2 NL - 2280 HV Rijswijk Tel. (+31-70) 340-2040, Fax: (+31-70) 340-3016	Authorized officer Georgiou, Georgia

INTERNATIONAL SEARCH REPORT

International application No

PCT/US2013/049472

C(Continuation). DOCUMENTS CONSIDERED TO BE RELEVANT		
Category*	Citation of document, with indication, where appropriate, of the relevant passages	Relevant to claim No.
Y	DANNY HONG ET AL: "1:2 Spatial Scalability Support for HEVC", 95. MPEG MEETING; 24-1-2011 - 28-1-2011; DAEGU; (MOTION PICTURE EXPERT GROUP OR ISO/IEC JTC1/SC29/WG11),, no. m18962, 25 January 2011 (2011-01-25), XP030047531, the whole document	12,28, 40,49
A	----- BROSS B ET AL: "High Efficiency Video Coding (HEVC) text specification draft 7", 9. JCT-VC MEETING; 100. MPEG MEETING; 27-4-2012 - 7-5-2012; GENEVA; (JOINT COLLABORATIVE TEAM ON VIDEO CODING OF ISO/IEC JTC1/SC29/WG11 AND ITU-T SG.16); URL: HTTP://WFTP3.ITU.INT/AV-ARCH/JCTVC-SITE/, , no. JCTVC-I1003, 10 May 2012 (2012-05-10), XP030112373, cited in the application section 8.4.3.1.5 Specification of Intra_DC Prediction Mode section 8.4.1 Derivation process for luma intra prediction mode section [7.4.6 Coding unit semantics]	1-49
A	----- XIONG L: "Reducing enh.-layer directional intra pred modes", 16. JVT MEETING; 73. MPEG MEETING; 24-07-2005 - 29-07-2005; POZNAN, PL; (JOINT VIDEO TEAM OF ISO/IEC JTC1/SC29/WG11 AND ITU-T SG.16),, no. JVT-P041, 19 July 2005 (2005-07-19), XP030006080, ISSN: 0000-0416 the whole document	1-49
A	----- "Advanced video coding for generic audiovisual services; H.264 (03/10)", ITU-T STANDARD, INTERNATIONAL TELECOMMUNICATION UNION, GENEVA ; CH, no. H.264 (03/10), 9 March 2010 (2010-03-09), pages 1-676, XP017467855, section [8.3 Intra prediction process] section [G.8.6.1 Derivation process for inter-layer predictors for macroblock type, sub-macroblock type, reference indices, and motion vectors] section [G.8.6.2.5 Derivation process for variables related to inter-layer intra prediction]	1-49
	----- -/--	

INTERNATIONAL SEARCH REPORT

International application No
PCT/US2013/049472

C(Continuation). DOCUMENTS CONSIDERED TO BE RELEVANT		
Category*	Citation of document, with indication, where appropriate, of the relevant passages	Relevant to claim No.
A	<p>I-K KIM ET AL: "High Efficiency Video Coding (HEVC) Test Model 6 (HM 6) Encoder Description", 8. JCT-VC MEETING; 99. MPEG MEETING; 1-2-2012 - 10-2-2012; SAN JOSE; (JOINT COLLABORATIVE TEAM ON VIDEO CODING OF ISO/IEC JTC1/SC29/WG11 AND ITU-T SG.16); URL: HTTP://WFTP3.ITU.INT/AV-ARCH/JCTVC-SITE/, , no. JCTVC-H1002, 27 April 2012 (2012-04-27), XP030111768, section [3.3 Intra Prediction] section [4.9.1 Intra prediction mode and parameters]</p> <p style="text-align: center;">-----</p>	1-49
A	<p>ANONYMOUS: "Joint scalable video model JSVM-12", 25. JVT MEETING; 82. MPEG MEETING; 21-10-2007 - 26-10-2007; SHENZHEN,CN; (JOINT VIDEO TEAM OF ISO/IEC JTC1/SC29/WG11 AND ITU-T SG.16), , no. JVT-Y202, 11 March 2008 (2008-03-11), XP030007295, ISSN: 0000-0087 section [2.3.1 Loss aware rate-distortion optimized macroblock mode decision]</p> <p style="text-align: center;">-----</p>	1-49