

(19) World Intellectual Property Organization
International Bureau



(43) International Publication Date
24 July 2008 (24.07.2008)

PCT

(10) International Publication Number
WO 2008/088591 A2

(51) International Patent Classification:
E04B 1/34 (2006.01)

(21) International Application Number:
PCT/US2007/079499

(22) International Filing Date:
26 September 2007 (26.09.2007)

(25) Filing Language: English

(26) Publication Language: English

(30) Priority Data:
11/535,282 26 September 2006 (26.09.2006) US

(63) Related by continuation (CON) or continuation-in-part (CIP) to earlier application:
US 11/535,282 (CON)
Filed on 26 September 2006 (26.09.2006)

(71) Applicant and

(72) Inventor: **MOORE, Barrett H.** [US/US]; 1001 Green Bay Road, Winnetka, Illinois 60093 (US).

(74) Agent: **KRATZ, Rudy I.**; Fitch, Even, Tabin & Flannery, 120 South LaSalle Street Suite 1600, Chicago, Illinois 60603 (US).

(81) Designated States (*unless otherwise indicated, for every kind of national protection available*): AE, AG, AL, AM, AT, AU, AZ, BA, BB, BG, BH, BR, BW, BY, BZ, CA, CH, CN, CO, CR, CU, CZ, DE, DK, DM, DO, DZ, EC, EE, EG, ES, FI, GB, GD, GE, GH, GM, GT, HN, HR, HU, ID, IL, IN, IS, JP, KE, KG, KM, KN, KP, KR, KZ, LA, LC, LK, LR, LS, LT, LU, LY, MA, MD, ME, MG, MK, MN, MW, MX, MY, MZ, NA, NG, NI, NO, NZ, OM, PG, PH, PL, PT, RO, RS, RU, SC, SD, SE, SG, SK, SL, SM, SV, SY, TJ, TM, TN, TR, TT, TZ, UA, UG, UZ, VC, VN, ZA, ZM, ZW.

(84) Designated States (*unless otherwise indicated, for every kind of regional protection available*): ARIPO (BW, GH, GM, KE, LS, MW, MZ, NA, SD, SL, SZ, TZ, UG, ZM, ZW), Eurasian (AM, AZ, BY, KG, KZ, MD, RU, TJ, TM), European (AT, BE, BG, CH, CY, CZ, DE, DK, EE, ES, FI, FR, GB, GR, HU, IE, IS, IT, LT, LU, LV, MC, MT, NL, PL, PT, RO, SE, SI, SK, TR), OAPI (BF, BJ, CF, CG, CI, CM, GA, GN, GQ, GW, ML, MR, NE, SN, TD, TG).

Published:

— *without international search report and to be republished upon receipt of that report*

(54) Title: RESOURCE CONTAINER AND POSITIONING METHOD AND APPARATUS

(57) Abstract: A transportable container is provided with at least one resource wherein the transportable container is positioned and secured at a predetermined location prior to an occurrence of a civilly-catastrophic event. Consideration-based private civil security subscriptions from subscribers are accepted with respect to providing civilly catastrophic event-based access to the transportable container. The container may be secured at the predetermined location and is configured such that the container remains operative to provide the civilly-catastrophic event-based access relative to the predetermined location after the transportable container experiences a civilly-catastrophic event.



WO 2008/088591 A2

**RESOURCE CONTAINER AND
POSITIONING METHOD AND APPARATUS**

Related Applications

[0001] This application is a continuation of U.S. Patent Application No. 11/535,282, filed on September 26, 2006, which is hereby incorporated by references herein in its entirety, and which is a continuation-in-part of each of the following U. S. applications, entitled:

[0002] SUBSCRIPTION-BASED PRIVATE CIVIL SECURITY FACILITATION METHOD as filed on March 17, 2006 and having application number 11/384,037;

[0003] SUBSCRIPTION-BASED CATASTROPHE-TRIGGERED MEDICAL SERVICES FACILITATION METHOD as filed on March 30, 2006 and having application number 11/394,350;

[0004] PERSONAL PROFILE-BASED PRIVATE CIVIL SECURITY SUBSCRIPTION METHOD as filed on April 11, 2006 and having application number 11/279,333;

[0005] RADIATION SHELTER KIT APPARATUS AND METHOD as filed on April 24, 2006 and having application number 11/379,929;

[0006] FRACTIONALLY-POSSESSED UNDERGROUND SHELTER METHOD AND APPARATUS as filed on May 2, 2006 and having application number 11/381,247;

[0007] SUBSCRIPTION-BASED CATASTROPHE-TRIGGERED TRANSPORT SERVICES FACILITATION METHOD AND APPARATUS as filed on May 2, 2006 and having application number 11/381,257;

[0008] SUBSCRIPTION-BASED MULTI-PERSON EMERGENCY SHELTER METHOD as filed on May 2, 2006 and having application number 11/381,265;

[0009] SUBSCRIPTION-BASED CATASTROPHE-TRIGGERED RESCUE SERVICES FACILITATION METHOD AND APPARATUS as filed on May 2, 2006 and having application number 11/381,277;

[0010] DOCUMENT-BASED CIVILLY-CATASTROPHIC EVENT PERSONAL ACTION GUIDE FACILITATION METHOD as filed on May 12, 2006 and having application number 11/383,022;

[0011] RESCUE CONTAINER METHOD AND APPARATUS as filed on May 26, 2006 and having application number 11/420,594;

[0012] PURCHASE OPTION-BASED EMERGENCY SUPPLIES PROVISIONING METHOD as filed on June 1, 2006 and having application number 11/421,694;

[0013] SUBSCRIPTION-BASED PRE-PROVISIONED TOWABLE UNIT FACILITATION METHOD as filed on June 12, 2006 and having application number 11/423,594;

[0014] RADIATION-BLOCKING BLADDER APPARATUS AND METHOD as filed on June 19, 2006 and having application number 11/425,043; and

[0015] PRIVATE CIVIL DEFENSE-THEMED TELEVISION BROADCASTING METHOD as filed on June 23, 2006 and having application number 11/426,231;

[0016] EMERGENCY SUPPLIES PRE-POSITIONING AND ACCESS CONTROL METHOD as filed on July 10, 2006 and having application number 11/456,472;

[0017] PRIVATE CIVIL DEFENSE-THEMED BROADCASTING METHOD as filed on August 1, 2006 and having application number 11/461,605; and

[0018] METHOD OF PROVIDING VARIABLE SUBSCRIPTION-BASED ACCESS TO AN EMERGENCY SHELTER as filed on August 1, 2006 and having application number 11/461,624;

[0019] SUBSCRIPTION-BASED INTERMEDIATE SHORT-TERM EMERGENCY SHELTER METHOD as filed on August 7, 2006 and having application number 11/462,795;

[0020] SUBSCRIPTION-BASED CATASTROPHE-TRIGGERED RESCUE SERVICES FACILITATION METHOD USING WIRELESS LOCATION INFORMATION as filed on August 7, 2006 and having application number 11/462,845;

[0021] PRIVATELY PROVISIONED SURVIVAL SUPPLIES DELIVERY METHOD as filed on August 15, 2006 and having application number 11/464;751;

[0022] PRIVATELY PROVISIONED SURVIVAL SUPPLIES SUB UNIT-BASED DELIVERY METHOD as filed on August 15, 2006 and having application number 11/464,764;

[0023] PRIVATELY PROVISIONED SURVIVAL SUPPLIES ACQUISITION METHOD as filed on August 15, 2006 and having application number 11/464,775;

[0024] PRIVATELY PROVISIONED SURVIVAL SUPPLIES CONTENT ACQUISITION METHOD as filed on August 15, 2006 and having application number 11/464,788;

[0025] METHOD TO PRIVATELY PROVISION SURVIVAL SUPPLIES THAT INCLUDE THIRD PARTY ITEMS as filed on August 15, 2006 and having application number 11/464,799;

[0026] WASTE DISPOSAL DEVICE as filed on August 16, 2006 and having application number 11/465,063;

[0027] SUBSCRIPTION-BASED PRIVATE CIVIL SECURITY RESOURCE CUSTOMIZATION METHOD as filed on August 23, 2006 and having application number 11/466,727;

[0028] PREMIUM BASED PRIVATE CIVIL SECURITY POLICY METHODS as filed on August 24, 2006 and having application number 11/466,953;

[0029] SUBSCRIPTION-BASED MOBILE SHELTER METHOD as filed on September 5, 2006 and having application number 11/470,156;

[0030] METHOD OF PROVIDING A FLOATING LIFE-SUSTAINING FACILITY as filed on September 13, 2006 and having application number 11/531,651;

[0031] PRIVATELY PROVISIONED SUB-UNIT-BASED SURVIVAL SUPPLIES PROVISIONING METHOD as filed on September 15, 2006 and having application number 11/532,461;

[0032] PRIVATELY PROVISIONED INTERLOCKING SUB UNIT BASED SURVIVAL SUPPLIES PROVISIONING METHOD as filed on September 25, 2006 and having application number 11/535,021;

[0033] the contents of each of which are fully incorporated herein by this reference.

Technical Field

[0034] This invention relates generally to facilitating the availability of resources.

Background

[0035] As powerful as the machinery of modern life appears, modern citizens are today perhaps more at risk of experiencing a serious disruption in their ability to prosper or even to survive en mass than is generally perceived. A serious disruption to any significant element of civilized infrastructure can produce catastrophic results for a broad swatch of a given civil community. Any number of natural and/or intentionally-caused events can significantly disrupt society's infrastructure and present a variety of differing threats and problems to the individual.

[0036] Many people believe and trust that their government (local, regional, and/or national) will provide for them in the event of such catastrophic occurrences. And, indeed, in the long view such is clearly a legitimate responsibility owed by any government to its citizens. That such is a consummation devoutly to be wished, however, does not necessarily make it so. Hurricane Katrina provided some insight into just how unprepared a series of tiered modern governmental entities may actually be to respond to even basic survival needs when a large-scale catastrophic event occurs. One may also observe that most communities simply cannot afford to staff and support a contingent capability to deal with a wide variety of likely infrequent and possibly unpredictable extreme events.

[0037] When a civilly-catastrophic event occurs, substantially sudden civil upheaval will often follow. Not only will many significant elements of society's infrastructure be seriously disrupted, but people in general are known to act in ways that are different and sometimes unexpected when faced with circumstances that threaten their well being or survival. This, coupled with the characterizing effects of the civilly-catastrophic event itself, can present an affected person with numerous challenges.

[0038] Modern governments typically do little to proactively ensure the ability to quickly and safely effect care of their citizens in the face of many civilly-catastrophic events. On the other hand, even if governments attempt to provide needed resources after such catastrophic events, the catastrophic nature of the event on infrastructure may render distribution of the resources difficult or impossible within a timely manner. Infrastructure such as roads, bridges, airports, and highways may be damaged or impassable rendering the transportation of such resources into the affected areas impossible or time consuming at the least. Moreover, not all communities or governments have the logistical ability to correctly position resources and equipment to quickly respond to an effected area. As witnessed by the effects of hurricane Katrina, it may be days or even weeks before regional, local, and national

governments can immobilize and transport sufficient resources into affected areas of greatest need.

[0039] Many catastrophic events are survivable presuming one has access to suitable emergency resources, particularly during the initial clear and present threat of the event. It is possible, of course, for individuals to obtain and store such needed resources in advance of any catastrophic event. Such an approach, however, presents a number of corresponding problems and issues. Attempting to take responsible actions to reasonably ensure one's own abilities in this regard can become, in and of itself, a seemingly insurmountable challenge. In addition, an individual may take the time to obtain and store emergency resources, but their storage site of choice may not be able to withstand the catastrophic event and/or the corresponding aftermath. As a result, the time and energy used to acquire and store emergency resources would be wasted if the resources themselves or the storage site does not withstand the event.

[0040] For these and other reasons, most if not all persons are typically bereft of a suitable store of resources that can be readily and quickly accessed in a time of need.

Brief Description of the Drawings

[0041] The above needs are at least partially met through provision of the resource container and position method and apparatus described in the following detailed description, particularly when studied in conjunction with the drawings, wherein:

[0042] FIG. 1 comprises a flow diagram as configured in accordance with various embodiment of the invention;

[0043] FIG. 2 comprises a flow diagram as configured in accordance with various embodiment of the invention;

[0044] FIG. 3 comprises a block diagram view as configured in accordance with various embodiments of the invention;

[0045] FIG. 4 comprises a block diagram view as configured in accordance with various embodiments of the invention;

[0046] FIG. 5 comprises a block diagram view as configured in accordance with various embodiments of the invention;

[0047] FIG. 6 comprises a block diagram view as configured in accordance with various embodiments of the invention;

[0048] FIG. 7 comprises a block diagram view as configured in accordance with various embodiments of the invention;

[0049] FIGS. 8A-8H comprise block diagram views as configured in accordance with various embodiments of the invention;

[0050] FIG. 9 comprises a block diagram view as configured in accordance with various embodiments of the invention;

[0051] FIG. 10 comprises a block diagram view as configured in accordance with various embodiments of the invention; and

[0052] FIG. 11 comprises a flow diagram as configured in accordance with various embodiments of the invention.

[0053] Skilled artisans will appreciate that elements in the figures are illustrated for simplicity and clarity and have not necessarily been drawn to scale. For example, the dimensions and/or relative positioning of some of the elements in the figures may be exaggerated relative to other elements to help to improve understanding of various embodiments of the present invention. Also, common but well-understood elements that are useful or necessary in a commercially feasible embodiment are often not depicted in order to facilitate a less obstructed view of these various embodiments of the present invention. It will further be appreciated that certain actions and/or steps may be described or depicted in a particular order of occurrence while those skilled in

the art will understand that such specificity with respect to sequence is not actually required. It will also be understood that the terms and expressions used herein have the ordinary meaning as is accorded to such terms and expressions with respect to their corresponding respective areas of inquiry and study except where specific meanings have otherwise been set forth herein.

Detailed Description of the Preferred Embodiment

[0054] Generally speaking, pursuant to these various embodiments, one provides a container adapted and configured to be transported with at least one resource, which may be, for instance, emergency survival items, life sustaining necessities, and/or non-necessities of human life. Consideration-based private civil security subscriptions are then accepted from one or more subscribers with respect to providing civilly-catastrophic event-based access to the transportable container. The transportable container is then positioned at a predetermined location prior to an occurrence of a civilly-catastrophic event, and secured at such location so that the container remains operative to provide the access relative to the predetermined location after experiencing the occurrence of the event. In addition, the container also preferably has a structure or support system sufficient to withstand the civilly-catastrophic event so that the container remains operative to provide the access after experiencing the event.

[0055] So configured, the subscriber or corresponding authorized beneficiaries (defined below) of such consideration-based private civil security subscriptions will have access to one or more pre-positioned, resource-containing units upon the occurrence of a catastrophic event. In this manner, during the aftermath of the civilly-catastrophic event, the resource(s) are conveniently positioned at the locale where most needed. The pre-positioned, resource-containing units eliminate or at least ameliorate the logistical and time consuming problem of transporting such resource(s) to the area of need when damaged or destroyed infrastructure may render such transport difficult or impossible. The authorized beneficiaries having access will be

comforted that the type and quantity of resources are preferably selected (and their maintenance governed) by experts and hence relieve the authorized beneficiary of responsibility in this regard.

[0056] These steps are facilitated without dependency upon governmental oversight, participation, or control. The particular resource (and/or the quantity of resources) provided can vary with the needs and requirements of the subscriber or authorized beneficiaries. Importantly, via these teachings an individual can take important steps to bring a considerably improved measure of security into their lives, knowing that, should a civilly-catastrophic event indeed be visited upon them, they will have extraordinary and reliable access to potentially needed resources.

[0057] These and other benefits may become clearer upon making a thorough review and study of the following detailed description. Referring now to FIG. 1, an illustrative process 100 provides for provision 101 of one or more transportable containers with at least one resource. This may comprise, for example, providing a transportable container of essentially any size or configuration including, but not limited to, a container having a rectangular, cylindrical, conical, or spherical shape. In general, for many application settings it may be appropriate that the transportable container comprise a rectangular shape formed as a fully enclosed unit having a floor, walls, and roof. As used herein, "transportable" refers to a container that is configured and arranged and has a size and weight such that it can be moved by a transport mechanism, such as trucks, cars, railcars, airplanes, other airships (i.e., blimps or other lighter than air aircraft), beasts of burden, ships, boats, hovercrafts, hydrofoils, hydroplanes, submarines, motorcycles, other amphibious craft, and combinations thereof to name but a few. For example, a common method to transport such a container would be to load the container onto a flatbed truck or railcar. Alternatively, the container may include wheels (for example, exemplary wheels 705 as are depicted in FIG. 7) or may be configured and arranged to have wheels selectively fit thereto (and removed therefrom) when needed so that the container may

be transported by being towed behind or pushed in front of a transport mechanism, such as car, truck, or train. Alternatively, the transportable container itself may comprise a movable vehicle such as a truck, car, railcar, airplane, airship, blimp, ship, boat, barge, hovercraft, hydrofoil, hydroplane, submarine, trailer, or other amphibious craft to name a few examples.

[0058] The process 100 also provides for the transportable container having at least one resource, which may include partially or fully providing the at least one resource in, on, attached to, or otherwise provided with the transportable container. The resource(s) can comprise any of a wide variety of items to assist the authorized beneficiaries after the occurrence of a civilly-catastrophic event. For example, the resource(s) may include a plurality of life-sustaining resources as pertain to a plurality of differing categories of life's necessities (such as, but not limited to, hydration (for example, water or other beverages), nourishment, shelter, environmentally borne threat abatement, medical supplies, environmental control equipment, weapons and so forth).

[0059] Such resource(s) may also comprise consumable items (including consumable necessities of human life), non-consumable items (including non-consumable necessities of human life), or both. Illustrative examples of consumable items would include, but are not limited to: food supplies, potable water, batteries, personal hygiene supplies, and medical supplies, to note but a few. Illustrative examples of non-consumable items could include, but are not limited to: essential clothing items, personal protection items (such as face masks, gloves, foul-weather gear, and so forth), bedding items; food preparation items, power generation equipment, repair and maintenance tools, navigation equipment, communication items, and shelter items (such as, for example, a tent) to again note but a few.

[0060] The resource(s) may also include at least one non-necessity of human life. Illustrative examples in this regard might include, but are not limited to: a luxury

consumable item, a luxury non-consumable item; non-human nourishment (for example, pet food); non-essential clothing; barter medium (including, for example, precious metals in a convenient barterable form); an entertainment apparatus or content; an educational tool; physical conditioning, exercise, and maintenance training and equipment; crafts supplies and training; sports equipment and facilities; and comfort foods (for example, foods and other beverages primarily consumed for enjoyment and comfort (such as a pleasing mouthfeel or satisfying organoleptic properties) rather than just for nourishment or hydration; examples include but are not limited to candies, confections, snack foods, baked goods, sugared beverages, and alcoholic beverages) to note but a few.

[0061] If desired, the resource(s) may also include a variety of supplies, equipment, or other survival items. For example, the resource may include a transport or other vehicle as well as a vehicular fuel storage tank. In such a case, the resource can also comprise, at least in part, vehicular fuel (such as, for example, gasoline, diesel fuel, and so forth) that is then pre-positioned in the vehicular fuel storage tank. By one approach, this vehicular fuel storage tank can further comprise a fuel pump such that vehicular fuel stored in the vehicular fuel storage tank can be readily transferred to the transport or other vehicle.

[0062] Also if desired, the resource(s) may be one or more spare parts of choice. Such spare parts might comprise, for example, one or more spare tires, spare fuses, spare illumination sources (such as light bulbs), and spare mechanical, electrical, and other maintenance parts of various types. There are, of course, many other examples of suitable spare parts.

[0063] By another approach, the resource(s) can optionally include a source of water or a water purification apparatus. The source of water may be provided in a water storage tank along with a suitable apparatus to provide the water to the authorized beneficiary (for example, pumps, valves, and so forth). Rather than a store

of water, or in addition thereto, the water purification apparatus could be provided so that an authorized beneficiary would be able to cleanse water from an external source and render it potable. To dispense the water, the resource(s) may also include a fluid pump, such as an automatic or manual water pump or other device to transport and pressurize fluids. Water purification equipment and pumps are known in the art and require no further explanation here.

[0064] The resource(s) may also comprise medical facilities and/or any medical supplies, equipment, and implements associated therewith. For example, the container may include medical materials to provide for a variety of medical emergencies or treatment of a variety of medical conditions. The resource(s) may comprise X-ray equipment or other imaging platforms and tools, beds, various medicaments, or medical dressings to name a few. In addition, the container may comprise a mobile or temporary operating or treatment room including at least some of the needed equipment, instruments, preparatory materials, and supplies to perform operations, diagnose and/or treat medical conditions, and otherwise care for patients. In this regard, an interior area of the container may comprise a sterile environment or include the ability to render the interior a sterile environment when needed. Additionally, the resource(s) may also include a medical guide, which may be written, audio, and/or visually based, to provide instruction to the authorized beneficiary regarding how to perform medical procedures or diagnose symptoms.

[0065] The resource(s) may also comprise accommodations suitable for temporary occupation for one or more authorized beneficiaries. In this regard, for many application settings the resource may generally comprise simplified or limited facilities suitable for accommodating a temporary stay within the transportable container for a limited number of occupants. The simplified facilities may include, for example, one or more of: sleeping facilities, hygiene facilities, simple food preparation facilities, storage, communications facilities, and/or sanitation facilities (such as toilets, showers, disposal equipment, or other wash facilities). Other options for the

resource may include, but are not limited to, auxiliary electric power supplies and sources, lighting, temperature and/or humidity control, water and/or air purification, and so forth.

[0066] By another approach, the resource(s) can include a power source (such as a generator, an inverter/battery system, and so forth). The power source could be used to provide power to any of the resource items described herein requiring power. The power source could be used to provide power to the resource(s) prior to the access by the authorized beneficiary in order to maintain the condition of the resource(s), or the power source could be used by the authorized beneficiary after gaining access. In one form, the power source could include at least one of: a wind-based power generator (such as a windmill), a photonically-based power generator (such as a solar cell or solar array or the like), a fluid-based power generator (such as water-powered, fossil fuel-powered, or the like), thermo-electric power generator (using, for example, steam-power, radiant heat power, or the like), and/or a stored-energy source (such as a battery, fuel cell, or the like). A human or animal powered generator could also be provided if desired. Turning for a moment to FIG. 7, an exemplary power source 701 such as a photo cell can be positioned on an external surface 702 of the transportable container. Alternatively, the power source 701 may be positioned within an internal space 703 of the container or stowed therewithin for later use. In yet another form, the power source could be derived from an external power source coupled to the container after the container has been secured at the predetermined location. For example, the container could include an appropriate electrical connection such that it could be connected to a city's electrical grid via underground wiring or overhead electrical connection to power lines.

[0067] Optionally, the resource(s) may comprise refrigeration or an apparatus to provide refrigeration. In a typical embodiment in this regard, the refrigeration will comprise, at least in part, a thermally insulated storage container. By one approach, this thermally insulated storage container can be electrically powered. So configured,

external power can be applied via an appropriate electrical connection to any of the above described power sources. By yet another approach, in combination with or in lieu of the approach just mentioned, the refrigerated storage container can comprise a dual-mode device that is capable of operating, for example, using propane (or a tri-mode device that is capable of automatically selecting from amongst alternating current when available, direct current when available, and propane). These and other approaches to providing refrigeration are known in the art and hence require no further detailed description here.

[0068] By another approach, the resource(s) can also include communications facilities. This can comprise, as desired, one-way and two-way communications facilities. In this regard, if desired, the container can be configured with a radio frequency antenna mast. This can comprise a fixed-position mast or can comprise a retractable and/or otherwise extendable or movable mast that can be placed in position when needed. So configured, a wireless communications device of choice (such as, for example, a cellular telephone, transmitter, or other transmission device) can be operably coupled thereto to thereby extend the corresponding effective communications range of the device. This can further comprise, if desired, use of signal amplifiers to increase reception and/or transmission capabilities. As further described below, the communications facilities may be employed to verify the identity of an authorized beneficiary prior to permitting the subscribed-to access.

[0069] In another form, the resource(s) can also include monitoring tools, such as one or more surveillance devices. The monitoring tools may be used to monitor the conditions of the transportable container's outer surroundings. Such capabilities may be particularly useful in determining whether or not the clear and present threat exposure has been diminished or eliminated and, therefore, whether it is safe for the authorized beneficiary to approach or emerge from the transportable container. The monitoring tools may comprise at least one of: a periscope, a window, video transmission, photographic transmission, local sensors, and/or a closed-circuit

television to note but a few. Such tools may also provide information related to external temperature, air quality, environmental conditions, and the scope of damage as created by the occurrence of the catastrophic event. Such information may be helpful in determining the appropriate time and direction, for example, for the occupants of the container to approach or emerge from the container into the external environment.

[0070] In another form, the resource(s) may include a transmitter within the container to permit remote monitoring and surveillance of the container. Therefore, an authorized beneficiary may monitor the conditions of the container and/or the container's surroundings from a remote location. The authorized beneficiary will then be able to evaluate the ability to reach the container, the environmental conditions external to the container, and any potential threat or other danger surrounding the container safely from a remote location.

[0071] The transmitter may also include a locating signal (such as a flare, beacon, tracer, flag, illumination source, an Internet transmission, an audible transmission, a wireless transmission, a visual transmission, a microwave transmission, code, strobe, a radio transmission, a television transmission, a cellular transmission, a digital transmission, or combinations thereof to name but a few types of signals) that helps an authorized beneficiary or other authorized personnel locate the container at the predetermined location or in the event it is moved from the predetermined location. By one approach, the locating signal may be triggered upon the container being secured at the predetermined location. By another approach, the locating signal may be triggered automatically upon any movement from the predetermined location. By yet another approach, the signal may be triggered manually from a remote location in order to pinpoint the predetermined location or once it is discovered the container is not at the predetermined location.

[0072] Once secured at the predetermined location, the container may be moved for a variety of authorized and unauthorized reasons. For example, as discussed further below, in some cases there may be a need to reposition the container to a second predetermined location. On the other hand, unauthorized movement of the container may also occur through theft, damage, or other unauthorized sources. Furthermore, the container may exhibit unwanted movement as a result of the civilly-catastrophic event itself. The locating signal, therefore, will permit the authorized beneficiary or other authorized personnel to locate the container after such movement.

[0073] Optionally, the transportable container may be mislabeled as to its contents so that a non-subscriber or non-authorized beneficiary is unaware of the at least one resource provided by the container. The mislabeling can be in the form of an absence of a label or possibly an incorrect label as to the container's resource. The incorrect label may be in the form of a code such that only those aware of the code are apprised of the container's resource. In this manner, only subscribers or authorized beneficiaries would be knowledgeable about the container's resource.

[0074] In another approach, at least a portion of an outer surface of the container may include an indicia so that the container is highly visible. In one form, the outer surfaces of the container may be painted a distinctive color or have easily recognizable markings (such as stripes, shapes, multi-colors) rendering the position of the container obvious to an authorized beneficiary. Such indicia may be advantageous in the event the container is partially covered with debris or other materials after experiencing the civilly-catastrophic event.

[0075] Again referring to FIG. 1, this process 100 then provides for accepting 102 consideration-based private civil security subscriptions from subscribers with respect to providing civilly-catastrophic event-based access to the transportable container. This right of access can pertain, if desired, to a predetermined period of time. For example, a given subscription can relate to providing access to the transportable

container for a one year period of time for one or more authorized beneficiaries as correspond to that subscription.

[0076] By one approach, these subscriptions may be accepted by, for example, a for-profit business. By another approach a not-for-profit business (such as a membership-based entity) may be the appropriate entity to offer and accept such subscriptions.

[0077] As noted, these teachings provide for a subscription-based approach. As used herein, the term "subscription" shall be understood to refer to and encompass a variety of legal mechanisms. Some relevant examples of subscription mechanisms are provided in U.S. Application No. 11/384,037, which is incorporated herein by reference in its entirety, but these teachings are not limited to the subscriptions methods provided therein.

[0078] If desired, a plurality of differentiated subscription opportunities can be offered. This plurality of differentiated subscription opportunities can correspond, for example, to providing access to differing transportable containers, contents, or both. As but one very simple illustration in this regard, such subscription opportunities can differ from one another at least with respect to cost. This, in turn, provides subscriber choice with respect to selecting a particular subscription that best meets their specific needs and/or budget limitations. For example, one subscription can provide for access to a relatively large transportable container that contains a relatively large store of resources while another less expensive subscription can provide for access to a relatively smaller transportable container than contains a relatively smaller store of resources. As another example, different subscriptions can be provided that reflect different combinations and quantities of the resources that are pre-positioned within the transportable containers. Other possibilities are of course possible.

[0079] These teachings also readily encompass the notion of a given subscriber providing such a subscription for an authorized beneficiary other than themselves.

Such might occur, for example, when one family member procures such a subscription for one or more other family members. Another example would be for a company to subscribe on behalf of named key employees, family members of such key employees, and so forth. Other examples no doubt exist.

[0080] As noted, these subscriptions relate to providing access to one or more transportable containers having at least one resource in the event of a civilly-catastrophic event. Such access may be predicated, if desired, upon a requirement that the civilly-catastrophic event be one that persists in substantial form for more than a predetermined period of time (such as one hour, one day, one week, and so forth) or that causes at least a predetermined amount or degree of infrastructure impairment or other measurable impact of choice. In addition, or in lieu thereof, such access may be predicated, if desired, upon a requirement of a particular level of objectively or subjectively ascertained likelihood that a particular category or kind of civilly-catastrophic event will occur within a particular period of time.

[0081] As used herein, "civilly-catastrophic event" will be understood to refer to an event that substantially and materially disrupts a society's local, regional, and/or national infrastructure. Such a civilly-catastrophic event can include both a precipitating event (which may occur over a relatively compressed period of time or which may draw out over an extended period of time) as well as the resultant aftermath of consequences wherein the precipitating event and/or the resultant aftermath include both the cause of the infrastructure interruption as well as the continuation of that interruption.

[0082] A civilly-catastrophic event can be occasioned by any of a wide variety of natural and/or non-naturally-caused disasters. Examples of natural disasters that are potentially capable of initiating a civilly-catastrophic event include, but are not limited to, extreme weather-related events (such as hurricanes, tsunamis, extreme droughts, widespread or unfortunately-targeted tornadoes, extreme hail or rain, and the like,

flooding, and so forth), extreme geological events (such as earthquakes, volcanic activity, and so forth), extreme space-based collisions (as with comets, large asteroids, and so forth), extreme environmental events (such as widespread uncontrolled fire or the like), a severe disease-based event, a severe agricultural event (such as a large scale crop failure), a severe natural shortage of a life-sustaining resource, and global or regional pandemics, to note but a few.

[0083] Examples of non-naturally-caused disasters capable of initiating a civilly-catastrophic event include both unintended events as well as intentional acts of war, terrorism, madness or the like. Examples of non-naturally-caused disasters capable of such potential scale include, but are not limited to, nuclear-related events (including uncontrolled fission or fusion releases, radiation exposure, and so forth), acts of war, the release of deadly or otherwise disruptive biological or chemical agents or creations, and so forth.

[0084] It would also be possible to supplement such access by permitting access to the transportable container upon the occurrence of some other event or circumstance that might present the authorized beneficiary with a serious challenge while not itself necessarily rising to the level of a civilly-catastrophic event. For example, if desired, access to the subscribed-to assets might be permitted when an authorized beneficiary's home is destroyed by fire.

[0085] Again referring to FIG. 1, the process 100 then provides for positioning 103 the transportable container at a predetermined location and then securing 104 the transportable container at such location prior to the occurrence of a civilly-catastrophic event. In this regard, the container is preferably secured in a manner and in a configuration such that the container remains operative to provide the subscribed to access relative to the predetermined location after the container experiences the event. In addition, the container preferably includes a structure, support, or other reinforcing

arrangement so that the container itself remains operative to provide the subscribed to access after experiencing the event.

[0086] Referring now to FIGS. 2 and 3, positioning 103 the transportable container may include a variety of positioning strategies—a few are discussed below. Other strategies and approaches, of course, are also possible. For example, one or more transportable containers 300 may be positioned 201 in one of a plurality of distinct predetermined locations 301. In one approach, each predetermined location 301 and secured container 300 is spaced at least and/or within or about a predetermined distance X from another predetermined location 301 and secured container 300. The distance X may vary from container to container, but about 5 to about 10 miles may be suitable for many application settings. Additionally, by one approach the at least one predetermined location 301 and the secured container 300 can be relatively proximal to a populated area (such as a city, community, town, or other urban and semi-urban area). The distance to such a populated area may vary depending on the geographic size, the population, the nature of the civilly-catastrophic event, various environmental conditions, and/or the surrounding terrain, but for many purposes may be within a relatively short walk from a population base or at least one authorized beneficiary.

[0087] Referring to FIGS. 2, 4, and 5, another positioning strategy includes first staging 202 a plurality of containers 300 at an initial staging position 401, and then transporting 203 the containers 300 from the initial position 401 to one of a plurality of predetermined locations 301 in advance of a civilly-catastrophic event 402. At the initial position 401, the containers are not necessarily secured thereto, but if desired may be secured in a manner so that they may be transported 203 to the predetermined location 301 when needed. If desired, a plurality of initial staging positions 401 may also be used as shown in FIG. 5. In this manner, a portion of the plurality of containers 300 may be staged 204 at each of the plurality of initial locations so that deployment to the predetermined locations 301 may be better optimized. This portioned positioning

strategy is beneficial because the optimal predetermined location(s) 301 may not be known until the true nature, location, path, or scope (among other factors) of the civilly-catastrophic event 402 are understood. Therefore, by employing the use of one or more initial staging positions 401, the deployment of the containers 300 at the final predetermined locations 301 can be better optimized for their use after the event.

[0088] In some instances, the predetermined location 301 may need to change based on various factors. Referring to FIGS. 2 and 5, the process 100 also contemplates the repositioning 205 of one or more of the transportable containers from the predetermined location 301 to a second predetermined location 501. Once repositioned at the second predetermined location 501, the container 300 is then secured 206 at the second predetermined location in a manner and configuration similar to how the container 300 was secured to the predetermined location 301. That is, the container can be secured in a manner and in a configuration such that the container remains operative to provide the subscribed to access relative to the second predetermined location after the container experiences the event. These teachings will also accommodate additional such moves if desired. As discussed previously, after such repositioning, the locating signal may be automatically or manually triggered if desired.

[0089] Referring to FIGS. 1, 6, and 8A-8H, as mentioned above the process 100 provides for the securing 104 of the container at the predetermined location 301. By one approach, the container is secured 104 with one or more anchor members 602 in a manner and in a configuration such that the container remains operative to provide the subscribed to access relative to the predetermined location after the container experiences the event. For example, the one or more anchor members 602 are sufficient to retain the container 300 either at the predetermined location or relative to the predetermined location upon experiencing a civilly-catastrophic event. In one example, the anchor 602 is capable of securing the container relative to the predetermined location 301 when experiencing wind speeds of greater than 155 mph

and water storm surges of greater than 18 feet (for example, a category 5 hurricane or an F5 tornado (typically associated with wind speeds of 261-318 miles per hour)). The anchor member 602 and secured container may also, if desired, be configured and arranged to be able to withstand other forces, such as a shock wave from explosives, undue heat, and so forth.

[0090] In one form, the anchor member 602 may include at least one of bolts, screws, chains, cement, anchors, nails, adhesive, bands, straps, cables, caissons, rebar, tethers and/or stakes to name but a few types of suitable anchor members. If desired, the anchor member 602 may also include a combination of such anchor types. Optionally, each anchor member 602 may be coupled to another anchor member 602.

[0091] There are a variety of known methods to employ the anchor members 602 to provide the above described attachment to the predetermined location 301. A few examples are provided in FIGS. 8A-8H, other attachment methods are of course possible. By one approach, as illustrated in FIG. 8A, the container 300 may be secured to a ground surface 801 by driving one or more caissons 802 into the ground 801 a sufficient length to provide a stable securing point 803 and then fastening the container 300 to the caissons 802 through the use of bolts and chains 804. In another approach, shown in FIG. 8B, the container 300 may be secured to the ground 801 by providing a cement foundation 806 buried several feet into the ground and then fixing the container to the cement foundation 806 using one or more straps or cables 807 or rebar 808. In still another approach, as shown in FIGS. 8C and 8D, the container 300 may be partially (FIG. 8C) or fully (FIG. 8D) buried within the ground 801 where several layers or feet of earth, dirt, rocks, or the like provide the securement. If partially buried, a point of access 809 can be positioned above the ground level. If fully buried, the point of access 809 may also include appropriate tunnels or other access through the layers of earth or dirt. In yet another approach, as shown in FIG. 8E, one or more straps 810 (that may comprise chains, belts, cables, or other elongate members) are wrapped around an outer surface of the container 300. Ends of

the straps are attached to anchors 811 driven into the ground. As shown in FIG. 8F, the container may also be secured via a tether 812 that is attached to an anchor member 813 driven into the surface 801. The tether 812 may have a predetermined length Y so that the container 300 is positioned to float upon a body of water (such as a storm surge) and still remained anchored to the ground 801 through the tether 812.

[0092] Rather than securing the container to the ground, the container 300 may also be secured to a pre-existing structure 814 as shown in FIG. 8G. To this end, the container 300 may be secured to a bridge abutment, a building foundation, an existing tower, or other existing secure structure. In one approach, the container may be secured by driving the anchor members 602 (such as bolts, spikes, nails, and so forth) into the building foundations or, in another approach, by using straps, cables, chains, or other anchor members to secure the container 300 to the leg of a tower or bridge abutment.

[0093] As mentioned above, the process 100 may provide for a plurality of containers 300 to be secured at the predetermined location 301. In this regard, the containers may be individually secured or may be secured together in some sort of arrangement as shown in FIG. 8H. For instance, the plurality of containers 300 may be stacked one on top of the other, or the containers may be locked together in a side-by-side arrangement.

[0094] Referring back to FIG. 7, the container 300 may also include one or more mechanisms 704 to deploy or secure the anchor member 602 when at the predetermined location. In this manner, the container is generally configured to self-secure, and generally no other equipment is needed to be transported to the predetermined location 301 in order to secure the container. Several such mechanisms are known in the art for deploying, securing, or driving the anchor members 602 into the ground or other structure. The mechanism 704 will vary depending on the type of anchor 602 selected. For example, the mechanism 704 may include pneumatic guns (to

deploy bolts, anchors, nails, stakes, or the like), cement mixing equipment, excavation equipment, and/or hydraulic or pneumatic pylon drivers (to deploy anchors, cables, rebar, caissons, posts, or the like) to name but a few examples. There are also other acceptable types of mechanisms suitable to deploy the anchors. If desired, the mechanisms 704 may be coupled together such that multiple mechanisms may deploy in unison.

[0095] Turning to FIGS. 6-10, an exemplary transportable container 300 will be described in more detail. As noted above, skilled artisans will appreciate that this illustrative transportable container 300 is illustrated for simplicity and clarity and has not necessarily been drawn to scale. For example, the dimensions and/or relative positioning of some of the elements in the figures may be exaggerated relative to other elements.

[0096] As noted, the container 300 can comprise an enclosed structure formed of walls, a floor, and a roof that has a sufficient size and shape to include or to provide the resource(s). As discussed above, the container can assume a rectangular, cylindrical, conical, or pyramidal shape; however, other shapes are of course possible. In one example, as schematically illustrated in Fig. 6, the container 300 comprises a rectangular shipping container 601, which may be about 20 to about 40 feet long and about 10-15 feet high. These teachings will readily accommodate a shipping container that can be transported by rail car or truck. Alternatively, the container itself may comprise a boat, ship, barge, vehicle, aircraft, railcar, truck, car, airplane, airship, blimp, ship, submarine, hovercraft, hydrofoil, hydroplane, trailer, shed, or crate.

[0097] In one aspect, the transportable container 300 includes a reinforcing arrangement 603 that would enable the container to remain operative after experiencing a civilly-catastrophic event or otherwise provide protection from a number of threats. In general, the reinforcing arrangement 603 may include a structural reinforcement, an environmental protection, or other strengthening

arrangement configured to enable the container to withstand the event or other potential threats. The reinforcing arrangement can include, for example, providing the container with sufficient strength or other capabilities to withstand significant and/or repeated impacts with moving objects, exposure to undue heat or cold, exposure to flooding and/or immersion, looting and/or vandalism activities, exposure to caustic agents, shock waves from explosives, and so forth as desired and/or as may be appropriate to a given application setting. Such strength or capabilities may be owing, for example, to materials as are employed to construct the container and/or the specifics of the design of the container itself.

[0098] By one approach, the environmental protection of the transportable container 300 can comprise a substantially air-tight container or substantially air tight seals surroundings access points, joints, seams, and other junction points. This environmental protection can be helpful, for example, to prevent airborne contaminants from entering the transportable container 300. If desired, the transportable container 300 can optionally be configured to further include an air mover/filter system to thereby permit exterior filtered air to be drawn into the interior of the transportable container 300 to thereby selectively create positive air pressure relative to external ambient conditions. Positive air pressure will, in turn, aid with respect to urging external air borne contaminants away from such openings as may exist in the container 300. When so configured, those skilled in the art will recognize that the container 300, when at least partially emptied of its contents (or when space is otherwise provided even when fully stocked) can also serve as at least a temporary shelter for one or more persons and will at least aid in protecting such persons from dangerous air-borne contaminants.

[0099] By another approach, the environmental protection may include a radiation-blocking barrier. For example, the radiation-blocking barrier may be a considerable mass placed between the container and the source of radioactivity. The considerable mass may include at least 2 meters of earth covering the container 300.

This depth can vary, of course, with the nature of the dirt itself, as a greater depth below less dense earth may be necessary to provide a same level of radiation blockage as a lesser depth of more dense earth. The radiation-blocking barrier may also be a radiation-blocking bladder encasing the container. This radiation-blocking bladder may be used in addition to or in lieu of placing the container underground. The radiation-blocking bladder may be at least substantially filled with liquid (such as, but not limited to, water) to comprise a radiation barrier. Alternatively (or in combination therewith), the walls, ceiling and/or floor of the transportable container may incorporate, or be encased by, ionizing radiation shielding such that part, or all, of the transportable container is shielded.

[0100] By another approach, the environmental protection may comprise an insulation layer or an arrangement that renders the container substantially fireproof. For example, the container 300 may be at least partially comprised of heat resistant material to thereby aid in preventing the interior of the container from becoming unsuitable for human habitation due to fire within or around the location of the container. Fire proof materials, insulations, and heat resistant materials are known in the art and therefore not described further herein.

[0101] In another form, the environmental protection may comprise a water-proof seal or other fluid-sealing arrangement that renders the container substantially waterproof. This feature is particularly desirable in the case of certain extreme weather-related events (such as, for example, tsunamis, rain, flooding, and so forth) and this feature is highly desirable for a transportable container that is also arranged and configured to float or be submersible. To this end, the transportable container 300 may also be arranged and configured to have a temporary or permanently substantially positive buoyant configuration so that the container will float in a liquid, such as fresh water or salt water bodies. A buoyant or floating container may be helpful, for example, during a land-based catastrophic event, or when land space is in limited supply. Further, a container may be desired when liquid may be needed as a

transportation medium. In addition, container may be configured and arranged to be submergible in the body of water. Submerging the container may be particularly beneficial during certain types of threats or events, such as, for example, radiation exposure or widespread fire.

[0102] By another optional approach, the structural reinforcement may be armor protection to the container. The armor can be designed to stop at least low caliber small arms fire and may offer higher ballistic protection if desired, including bulletproof windows, louvered view ports, and armored occupant compartments, to note but a few examples.

[0103] In another form, the structural reinforcement may include a support or support member sufficient to retain the integrity of the interior space upon the container experiencing a civilly-catastrophic event. In this regard, the support would be sufficient to structurally harden the container in order to resist collapse or breach. Preferably, the support member would enable the container, and in particular the interior space thereof, to remain accessible and operative after the container has experienced a civilly-catastrophic event so that the at least one resource therein would be obtainable and usable. Examples of a suitable support include, but not limited to, a matrix structure, framing, gussets, ribs, cross-supports, honeycomb materials, high strength metals, and/or high strength plastics, to name a few. In one example, the reinforcing arrangement is capable of retaining the integrity of the interior space upon the container experiencing wind speeds of greater than 155 mph and water storm surges of greater than 18 feet (as may accompany, for example, a category 5 hurricane or an F5 tornado). While the structural reinforcement may surround the interior space of the container as illustrated schematically in FIG. 6, the structural reinforcement may also provide cross support 606 through the interior space via braces, ribs, or other cross-support members.

[0104] By another approach, the environmental protection may include a climate control mechanism to control one or more of temperature, humidity, pressure, or other environmental conditions of the container's interior space. In one example, the container may also include a manual or automatic valve operable on-site or remotely to equalize any pressure differential between a sealed interior space of the container and any external pressure. The transportable container, therefore, would be equipped to maintain a substantially constant pressure internally within the container independent of any weather related low or high pressure changes. Temperature, humidity, and pressure monitoring equipment as well as climate regulating equipment (such as air conditioners, humidifiers, and heaters, to note but a few) are known in the art and not described further herein.

[0105] Turning to FIG. 9, the container 300 may also include an arrangement for organizing, storing, positioning or otherwise conveniently providing the at least one resource, which can be accomplished in any of a variety of ways depending on the type of resource, the access need, the priority of the resource, and/or on the authorized beneficiaries that would be provided access to the container. By one approach, the at least one resource can simply be loosely placed inside the container 300. By another approach, the resource can be stored in one of a plurality of units 901 within the container 300. For example, a unit 901 may be a plurality of resources bundled together (using, for example, boxes or other secondary containers, shrink wrap material, straps, tarps, tie-downs, or the like) and then placed inside the container. When taking this approach, if desired, the resultant bundle can itself be placed on a pallet to facilitate loading and unloading the bundle with respect to the container 300. Other approaches are also possible. For example, if desired, the units 901 within the interior of the container 300 can be configured with shelves, hooks, pockets, drawers, and other storage accoutrements to facilitate the positioning of such resources. By yet another approach, resources that are intended for longer-term needs can be packed deeper within the interior of the container, while items intended for

shorter-term or more immediate needs can be positioned closer to an access door. So configured, resources that are more likely to be needed earlier than other resources are placed to avoid having to remove an undue number of presently-unneeded resource in order to access the presently-needed items.

[0106] If desired, the units 901 may comprise one or more separate storage bins or subdivided, enclosed secure holding areas formed, for example, in a wall of the container 300 (wherein the term "wall" will be understood to refer to any partition such as a vertical wall, a roof, a floor, and so forth). This can comprise, for example, a user-lockable enclosed secure holding area (such as a key-locked or combination lock-protected safe or the like) and/or a camouflaged user-accessible enclosed secure holding area that is not readily discernable to ordinary observation (where, for example, the door to the enclosed secure holding area is accessible externally and hidden behind other built-in structures or itself blends in with other proximal structures and design elements).

[0107] In another approach, these separate or subdivided storage units 901 could be sized and configured to contain and store the previously provided personal resources from a particular authorized beneficiary. Therefore, an individual authorized beneficiary could provide a variety of personal resources for storage in the container so that they would be obtainable after the event. Each storage unit could be accessible through a locking mechanism to which only the particular authorized beneficiary has the code or key to access the unit with their resources.

[0108] By yet another approach, the units 901 may be a plurality of separate compartments, portions, or areas within the container. If desired one or more of these units 901 may include a separate locking mechanism 902 such that each unit 901 requires a different key, device, code, or authorization to unlock such unit. Therefore, even if the authorized beneficiary gains access to an interior space 903 of the container, such individual may be required to further unlock individual units 901 prior to

gaining access to the resource(s) within such unit 901. In this regard, an external entry 904 may be unlocked remotely providing initial access to the interior 903 of the container 300. Once within the container 300, an identity of the authorized beneficiary may be confirmed prior to providing further access to any of the individual units 901. Providing access to the interior space 903, the units 901, and/or the unlocking thereof as well as the confirmation of the authorized beneficiary's identity are further described in various exemplary approaches below.

[0109] Referring now to FIG. 10, the container 300 may optionally include a separation device 1001 configured so that the container 300 may be divided into a plurality of separate, individual sub-container units 1002 and 1003, for example. In this manner, once the container 300 is transported to the predetermined location 301, it may be subdivided into the smaller units 1002 and 1003, each of which are secured in the manner previously discussed. The separation device 1001 preferably includes any apparatus configured to hold multiple components of a structure together and then permit relatively easy separation. For example, for a container 300 comprising two separate container units 1002 and 1003, the separation device 1001 may include nuts and bolts holding both containers 1002 and 1003 together; a chain, strap, or other element encircling both container 1002 and 1003; or clamping devices that hold both containers 1002 and 1003 together. There are of course other examples.

[0110] Turning again to FIGS. 6 and 7, the transportable container 300 is preferably configured with at least one point-of-entry 604, which can comprise an access door to provide entry and exit to the container. By one approach, the point-of-entry 604 is positioned on a wall of the container so that the interior space of the container may be accessed after the container has experienced a civilly-catastrophic event. To this end, the container 300 may also include a plurality of access points 604 providing access from a plurality of directions.

[0111] This point-of-entry 604 can comprise any movable-type barrier of choice including, but not limited to, a pivoting door, a sliding door, a multi-part door, and so forth. By one approach, this point-of-entry can have a corresponding locking mechanism 605 (as mentioned above, this locking mechanism may also apply to the locking mechanism 902 of the units 901). Any suitable locking mechanism can be employed in this regard including, but not limited to, key-based locks, combination locks, electronic locks, and so forth. When so configured, an authorized beneficiary may, if desired, be the only party having the ability to unlock the locking mechanism. More typically, however, it may be preferred to permit other authorized personnel to also have such access in order to facilitate, for example, maintenance of the transportable container and its contents. By one approach, the locking mechanisms can be opened locally or can be opened remotely.

[0112] Referring again to FIGS. 1 and 6-7, the process 100 optionally provides for the confirming 105 of the authorized beneficiary's identity prior to unlocking the locking mechanism 605 (or mechanism 902) to permit access through the point of entry 604 (or into the units 901). The container 300 and/or locking mechanism 605 or 902, therefore, may include or provide a suitable apparatus to confirm the authorized beneficiary's identity. This may comprise, if desired, use of a mechanism that the authorized beneficiary carries with them to confirm their authorized status in this regard. The identify of the authorized beneficiary may be confirmed through the use of personal property (such as an identification card, a still image, an admission card) or through, for example, a biometric-based identity authentication process that relies upon fingerprints or other asperity-based features, retinal patterns, voice prints, or some other relatively unique aspect of the human body or condition. In addition, the authorized beneficiary's identity may be confirmed through the use of a visual confirmation, a password, a pass code, a word code, or other authorization code.

[0113] By one approach, the pass code, the password, the word code, or other authorization code may be provided to an authorized beneficiary through a

transmission, which can be coded or scrambled if desired, including at least one of: an Internet transmission, a wireless transmission, a radio transmission, a television transmission, an audible transmission, a visual transmission, a microwave transmission, a cellular transmission, a digital transmission. For example, the transmission may be provided through the mechanisms described in U.S. Application Serial Numbers 11/426,231 or 11/461,605, both of which are incorporated herein in their entirety. The code or authorization may be common to all transportable containers, may be common to a portion of the transportable containers in a particular region or geographic area, or may be specific to a particular container or authorized beneficiary.

[0114] In another approach, the access to the container and resource(s) may also be staged, such that the access may be provided through the point-of-entry 604 via one of the unlocking or identity confirmation procedures as described above, and then subsequent access may be provided to one or more of the individual units 901 through a similar unlocking or identity confirmation procedure. In this regard, for example, the outer point-of-entry 604 may be opened remotely via a wireless signal providing initial access to any individual or authorized beneficiary. As described above, once within the container, the authorized beneficiary will need to unlock one of the units 901 to gain access to the resource(s). Access to the units 901 may be obtained by employing a code or authorization provided to the authorized beneficiary (as described above) or by the authorized beneficiary utilizing communications equipment provided within the container to establish their identity to a third party, who may then provide the needed code/authorization or remotely unlock (via a wireless signal or other transmission) the individual units 901.

[0115] Referring again to FIG. 1, after the authorized beneficiary's identity is confirmed and access is obtained, the process 100 then optionally provides for a notification 106 of at least one designated contact person that the authorized beneficiary has gained access. Such notification can occur automatically without the

input or knowledge of the authorized beneficiary gaining access. The process 100 may then provide for documenting 107 the identity, time, duration, and/or frequency of the access for each individual authorized beneficiary that is authorized to access the transportable container. Documentation may also include documenting what resource(s), if any, the authorized beneficiary uses or takes from the container. Along with such documentation, the process 100 also optionally provides for the documentation 108 of any unauthorized attempts or actual unauthorized access.

[0116] Turning to FIGS. 1 and 11, the process 100 also provides for optionally maintaining 109 the transportable container pending a need to permit subscription-based access to the transportable container upon occurrence of a catastrophic event. Such maintenance 109 can comprise, for example, maintaining both operational serviceability of the transportable container as well as the utility of the at least one resource provided or contained therein.

[0117] Such maintenance 109 can also optionally comprise making adjustments to the at least one resource to reflect dynamically changing circumstances as occur during the consideration-based private civil security subscription period. As one illustration, a new resource may become available that is particularly useful in dealing with or otherwise surmounting some condition that may likely arise upon the occurrence of a particular kind of civilly-catastrophic event. In such a case, maintaining such resource can readily accommodate updating the acquired and stored resources to include a supply of this new item.

[0118] Accordingly, such maintenance 109 can readily comprise one or more of removing a particular one of the stored resources (as when a better substitute becomes available, when the item itself is shown to be less effective for its intended purpose than was originally thought, and so forth), adding additional ones of a particular resource (as when it becomes subsequently understood that more of a particular item is desirable to achieve a particular goal or purpose), adding at least one new stored

resource that is not already stored (as illustrated in the example provided above), and so forth.

[0119] Specifically referring to FIG. 11, in another approach, maintaining 109 the at least one resource may include monitoring 1101 an inventory status of the at least one resource. Such monitoring can include automatic monitoring such as, for example, where the container 300 includes equipment and/or sensors to automatically account for the use of or the removal of a particular resource. In this regard, the container 300 may include an inventory system to identify the status of the resource. Such status could be of only one particular resource (for example, such as the amount of water remaining) or could be a summary report of the percentage or number of each reference remaining or used as compared to an original or total quantity.

Alternatively, such monitoring can include an authorized beneficiary noting on a log or other recording device (for example, paper, computer, and the like) the use of or removal of a particular resource. Such monitoring may also include communication 1102 of an inventory status, such as a low inventory status, of the at least one resource. The communication may occur via the Internet, phone, wireless, or other suitable communication method. In this regard, maintenance 109 may also include restocking any low inventory of the at least one resource

[0120] Turning back again to FIG. 1, the process 100 also optionally provides guidance 110 to the secured transportable container for the authorized beneficiary. In one form, the guidance may include providing the location of the predetermined location 301 where one of the containers 300 is secured. Such guidance 110 will provide to the authorized beneficiary directions or coordinates to the predetermined location, and may also provide a summary of the at least one resource provided with each container at each predetermined location. In this regard, depending on which resource the authorized beneficiary needs, he or she can be directed to a particular predetermined location 301 and container 300.

[0121] In one approach, the guidance 110 may be provided through at least one of globally positioning system (GPS) coordinates, an Internet communication or broadcast, a verbal communication, a written communication, a wireless communication, or a visual communication to name a few. Of course, there may be other methods to provide such guidance. For example, the written communication may include the use of guide books, maps, or written directions to the predetermined locations. The visual communication may include at least one of a beacon, flare, strobe, illumination device, a flag, a symbol, or a code (such as a color code or alphanumeric code). The wireless communication may include at least one of a radio transmission, a television transmission, a cellular transmission, a digital transmission, an electronic transponder signal, or a beacon signal. Optionally, each separate transportable container 300 may include a unique guidance signature based on the resource contained therein or a guidance signature may be common to a plurality of container within a geographic region.

[0122] Turning again to FIG. 1, the process 100 may also provide for notifying 111 a third party upon any disturbance to the transportable container 300, preferably after such container has been secured at the predetermined location 301. As a result, the third party may rectify the disturbance as needed so that the subscribed to access may be provided to the authorized beneficiary. In one form, the disturbance may include any unauthorized actions surrounding the container, such as tampering, pilfering, unauthorized access, attempts at unauthorized access, unauthorized movement, attempts at unauthorized movement, unauthorized modifications, or other unauthorized intentional modifications to name but a few types of disturbances.

[0123] In yet another form, the disturbance may include other unplanned or unwanted events surrounding the container that may render access to the resource(s) difficult or complicated for the authorized beneficiary. The notification 111, therefore, permits the unwanted or unplanned event to be rectified so that the authorized beneficiary may obtain the subscribed to access. For instance, the disturbance may

include damage to the container that may have been sustained while experiencing the civilly-catastrophic event. Additionally, the disturbance may also include the unplanned submergence of the container in a fluid (such as a storm surge or other flood waters), the unplanned partial or complete burial of the container under debris (such as trees, earth, fallen structures, or other debris material that may result from the civilly-catastrophic event), or other unplanned, non-intentional movement (such as forces of the civilly-catastrophic event moving, repositioning, damaging, or other blocking access to the container) to name but a few examples. Of course, there are other unplanned or unwanted events or disturbances that may be occasioned on the container. The notification 111 permits such events and disturbances to be proactively addressed as needed.

[0124] So configured and arranged, resource(s) as may be helpful or even critical to easing the plight of authorized beneficiaries affected by a given civilly-catastrophic event are more likely to be quickly and relatively conveniently at hand. This, in turn, can greatly increase the tangible degree of civil security perceived and experienced by such persons. These teachings will readily accommodate a variety of approaches in this regard and these solutions are readily scalable to accommodate everything from relatively modest efforts to large scale preparatory activities.

[0125] Those skilled in the art will recognize that a wide variety of modifications, alterations, and combinations can be made with respect to the above described embodiments without departing from the spirit and scope of the invention, and that such modifications, alterations, and combinations are to be viewed as being within the ambit of the inventive concept.

CLAIMS

What is claimed is:

1. A method comprising:
 - providing a transportable container with at least one resource;
 - accepting consideration-based private civil security subscriptions from subscribers with respect to providing civilly-catastrophic event-based access to the transportable container;
 - positioning the transportable container at a predetermined location prior to an occurrence of a civilly-catastrophic event; and
 - securing the transportable container at the predetermined location such that the container remains operative to provide the civilly-catastrophic event-based access relative to the predetermined location after the transportable container experiences a civilly-catastrophic event.
2. The method of claim 1, wherein providing a transportable container comprises providing a transportable container having a structure arranged and configured to remain operative to provide the civilly-catastrophic event-based access after the transportable container experiences a civilly-catastrophic event.
3. The method of claim 1, wherein the transportable container comprises a reinforcement arrangement.
4. The method of claim 2, wherein the transportable container comprises environmental protection.

5. The method of claim 4, wherein the environmental protection comprises a substantially water-proof seal.

6. The method of claim 4, wherein the environmental protection comprises a substantially air-tight seal.

7. The method of claim 4, wherein the environmental protection comprises an insulation layer.

8. The method of claim 4, wherein environmental protection comprises a positive air pressure capability to discourage airborne contaminants from entering the transportable container.

9. The method of claim 4, wherein the environmental protection comprises a radiation-blocking barrier.

10. The method of claim 4, wherein the environmental protection comprises a climate control mechanism to control at least one: temperature, humidity, pressure.

11. The method of claim 2, wherein the transportable container comprises a substantially positive buoyant configuration such that the transportable container will float on a liquid.

12. The method of claim 2, wherein the transportable container has a shape comprising at least one of: rectangular; cylinder; cone; sphere.

13. The method of claim 1, wherein the transportable container has a point of access to provide access to the at least one resource by an authorized beneficiary.

14. The method of claim 13, wherein the point of access is configured to be locked through a locking mechanism.

15. The method of claim 13, wherein providing a transportable container includes providing a plurality of transportable containers, each of the plurality of transportable containers having a point of access with a distinct locking mechanism.

16. The method of claim 13, wherein providing civilly-catastrophic event-based access further comprises unlocking a locked point of access from a location remote therefrom.

17. The method of claim 13, wherein the transportable container includes a plurality of compartments and each of the plurality of compartments including a distinct locking mechanism.

18. The method of claim 17, further comprising confirming an identity of an authorized beneficiary in order to unlock one of the plurality of compartments.

19. The method of claim 18, wherein the distinct locking mechanisms are unlocked remotely therefrom.

20. The method of claim 13, further comprising confirming an identity of an authorized beneficiary prior to providing the access to the transportable container.

21. The method of claim 20, wherein the identity of the authorized beneficiary is confirmed by at least one of: biometrics; an identification card; a still image; visual confirmation; an admission card; a password; a pass code; voice print; words.

22. The method of claim 21, further comprising providing one of the pass code, the password, or the words to an authorized beneficiary through a transmission including at least one of: an Internet transmission, a wireless transmission, a radio transmission, a television transmission, an audible transmission, a visual transmission, a microwave transmission, a cellular transmission, a digital transmission.

23. The method of claim 22, wherein the transmission is scrambled.

24. The method of claim 20, further comprising upon confirmation of the authorized beneficiary's identity, automatically notifying at least one designated contact person upon the subscriber's entry into the transportable container.

25. The method of claim 20, further comprising upon confirmation of the authorized beneficiary's identity, automatically documenting the identity of the access.

26. The method of claim 20, further comprising documenting unauthorized attempts at access.

27. The method of claim 1, wherein the transportable container has a size and weight configured to be moved by a transport.

28. The method of claim 27, wherein the transport comprises at least one of: truck, car, railcar, airplane, airship, blimp, ship, boat, hovercraft, hydrofoil, hydroplane, beast of burden, submarine, motorcycle, amphibious craft; and combinations thereof.

29. The method of claim 1, wherein the transportable container comprises one of: truck, car, railcar, airplane, airship, blimp, ship, boat, barge, hovercraft, hydrofoil, hydroplane, submarine.

30. The method of claim 1, wherein providing a transportable container comprises providing a transportable container mislabeled as to its contents such that a non-subscriber is unaware of the at least one resource therein.

31. The method of claim 1, wherein providing a transportable container comprises providing a transportable container including an indicia on at least a portion of an outer surface thereof rendering the container highly visible.

32. The method of claim 1, wherein the at least one resource comprises a life-sustaining necessity.

33. The method of claim 32, wherein the life sustaining necessity comprises at least one of: hydration, nourishment, shelter, security; environmentally borne threat abatement, medical supplies, environmental control equipment, weapons.

34. The method of claim 32, wherein the life-sustaining necessity comprises at least one of: a consumable necessity of human life; a non-consumable necessity of human life.

35. The method of claim 1, wherein the at least one resource includes a water purification apparatus.

36. The method of claim 1, wherein the at least one resource comprises water.

37. The method of claim 1, wherein the at least one resource includes a fluid pump.

38. The method of claim 1, wherein the at least one resource comprises a non-necessity of human life.

39. The method of claim 38, where the non-necessity of human life comprises at least one of: a luxury consumable item; a luxury non-consumable item; non-human nourishment; non-essential clothing; barter medium; an entertainment apparatus; an educational tool; physical conditioning, exercise, and maintenance training and equipment; crafts supplies and training; sports equipment and facilities; a comfort food item.

40. The method of claim 1, wherein the at least one resource comprises a consumable resource including at least one of: food supplies, potable water; finite air supplies, batteries, hygiene supplies, sanitation supplies.

41. The method of claim 1, wherein the at least one resource comprises a non-consumable resource including at least one of: clothing items, personal protection items, bed linens, beds, food preparation items, repair and maintenance equipment, evacuation tools, navigation equipment, rescue tools and supplies, shelter items.

42. The method of claim 1, wherein the at least one resource includes medical facilities and supplies associated therewith.

43. The method of claim 1, wherein the at least one resource includes living quarters.

44. The method of claim 43, wherein the living quarters includes at least one of: sleeping accommodations; food preparation facilities, personal hygiene facilities; sitting accommodations; sanitation facilities.

45. The method of claim 1, wherein the at least one resource includes a transport vehicle.

46. The method of claim 45, wherein the at least one resource includes a transport vehicle fuel storage tank.

47. The method of claim 1, wherein the at least one resource includes an inventory of spare parts.

48. The method of claim 1, wherein the at least one resource includes a power source.

49. The method of claim 48, wherein the power source includes at least one of: a wind-based power generator; a photonically-based power generator; a fluid-based power generator; thermo-electric power generator; stored-energy power generator.

50. The method of claim 1, wherein the at least one resource includes an apparatus to provide refrigeration.

51. The method of claim 1, wherein the at least one resource includes communication equipment.

52. The method of claim 1, wherein the at least one resource include a surveillance device.

53. The method of claim 52, wherein the surveillance device comprises a closed circuit television.

54. The method of claim 1, wherein the at least one resource includes a transmitter.

55. The method of claim 54, wherein the transmitter permits remote access to the transportable container.

56. The method of claim 54, wherein the transmitter permits remote surveillance of transportable container.

57. The method of claim 1, wherein the at least one resource includes a plurality of subdivided units sized and configured for a plurality of subscriber's previously provided personal resource.

58. The method of claim 1, wherein the at least one resource includes a locating signal comprising at least one of flare, beacon, tracer, flag, illumination source, an Internet transmission, an audible transmission, a wireless transmission, a visual transmission, a microwave transmission, code, strobe, a radio transmission, a television transmission, a cellular transmission, a digital transmission.

59. The method of claim 58, wherein the locating signal is triggered automatically when the container is moved.

60. The method of claim 58, wherein the locating signal is triggered manual in a location remote from the container.

61. The method of claim 1, wherein providing the transportable container comprises providing a plurality of transportable containers.

62. The method of claim 61, wherein the plurality of transportable containers are arranged together.

63. The method of claim 62, wherein the plurality of transportable containers are stacked.

64. The method of claim 62, wherein the plurality of transportable containers are locked together.

65. The method of claim 61, wherein positioning the transportable container comprises positioning each of the plurality of transportable containers at one of a plurality of distinct predetermined locations.

66. The method of claim 65, wherein each distinct predetermined location is spaced a predetermined distance from another distinct predetermined location.

67. The method of claim 66, wherein the predetermined distance is about 5 to about 10 miles.

68. The method of claim 66, wherein each of the plurality of transportable containers are located proximal to a populated area.

69. The method of claim 65, wherein positioning each of the plurality of transportable containers comprises:
staging the plurality of transportable containers at an initial position; and
transporting the plurality of transportable containers from the initial position to the plurality of predetermined locations in anticipation of the occurrence of a civilly-catastrophic event.

70. The method of claim 69, wherein staging the plurality of transportable containers at an initial position comprises staging a portion of the plurality of transportable containers at one of a plurality of initial positions.

71. The method of claim 1, wherein providing a transportable container comprises providing a transportable container configured to be subdivided into a plurality of smaller transportable containers.

72. The method of claim 1, wherein the predetermined location is proximate to the subscriber.

73. The method of claim 1, further comprising repositioning the transportable container from the predetermined location to a second predetermined location and securing the transportable container at the second predetermined location such that the container remains operative to provide the civilly-catastrophic event-based access relative to the second predetermined location after the transportable container experiences a civilly-catastrophic event.

74. The method of claim 1, wherein securing the transportable container includes the application of at least one of: bolts, screws, chains, cement, anchors, nails, adhesive, bands, straps, cables, caissons, rebar, stakes, tether.

75. The method of claim 74, wherein securing the transportable container comprises attaching a first end of the tether to the container, driving an anchor into a surface, and attaching a second end of the tether to the anchor.

76. The container of claim 75, wherein the container has a positive buoyancy and the tether has a length sufficient to permit the container to float on a body of water.

77. The method of claim 74, wherein providing a transportable container comprises providing a transportable container with a mechanism for securing the transportable container included therewith.

78. The method of claim 1, wherein securing the transportable container comprises securing the transportable container to a pre-existing structure.

79. The method of claim 1, wherein securing the transportable container comprises at least partially burying the transportable container in the ground.

80. The method of claim 79, wherein securing the transportable container comprises fully burying the transportable container underground.

81. The method of claim 1, further comprising maintaining the at least one resource pending a need to permit subscription-based access to the transportable container.

82. The method of claim 81, wherein maintaining the at least resource comprises monitoring an inventory status of the at least one resource.

83. The method of claim 82, further comprising communicating a low inventory status of the at least one resource.

84. The method of claim 1, further comprising providing guidance to the secured transportable container for the subscriber.

85. The method of claim 84, wherein the guidance includes at least one of: globally positioning system (GPS) coordinates, an Internet communication or broadcast, a verbal communication, a written communication, a wireless communication, a visual communication, a microwave transmission.

86. The method of claim 85, wherein the visual communication includes at least one of: a beacon, a flag, a code, flare, strobe, illumination source.

87. The method of claim 86, wherein the code includes at least one of: a color code, an alphanumeric code.

88. The method of claim 85, wherein the wireless communication includes at least one of: an analog transmission, a radio transmission, a television transmission, a cellular transmission, a digital transmission.

89. The method of claim 1, further comprising providing notification to a third party upon disturbance of the transportable container.

90. The method of claim 89, wherein the disturbance comprises unauthorized access to the transportable container.

91. The method of claim 89, wherein the disturbance comprises unauthorized movement of the transportable container.

92. The method of claim 89, wherein the disturbance comprises at least one of: submergence in a fluid, at least partially burying under debris, non-intentional movement.

93. A container configured to withstand a civilly-catastrophic event, the container comprising:

a support structure defining an interior space;

a reinforcing arrangement of the support structure arranged and configured such that the interior space remains accessible and operative after the container has experienced a civilly-catastrophic event;

a size and weight such that the container can be transported from a first location to a second location by a transport vehicle; and

a mechanical securing device arranged and configured to retain the container relative to the second location upon the container experiencing a

civilly-catastrophic event such that the container remains operative to provide access to the interior space.

94. The container of claim 93, wherein the reinforcing arrangement comprises a water-proof seal.

95. The container of claim 93, wherein the reinforcing arrangement comprises an air-tight seal.

96. The container of claim 93, wherein the reinforcing arrangement comprises a support sufficient to retain the integrity of the interior space upon the container experiencing a civilly-catastrophic event.

97. The container of claim 93, wherein the reinforcing arrangement comprises a radiation-blocking barrier.

98. The container of claim 93, wherein the reinforcing arrangement comprises a positive air pressure within the interior space sufficient to discourage airborne containments from entering the interior space.

99. The container of claim 93, wherein the reinforcing arrangement comprises a climate control mechanism to control one of temperature, humidity, and pressure of the interior space.

100. The container of claim 93, wherein the support structure has a shape comprising at least one of: rectangular; cylinder; cone; sphere.

101. The container of claim 100, wherein the support structure is a rectangular shipping container about 20 to about 40 feet long.

102. The container of claim 93, wherein the container comprises one of: boat, ship, barge, vehicle, aircraft, railcar, truck, car, airplane, airship, blimp, ship, hovercraft, hydrofoil, hydroplane, trailer, shed, crate.

103. The container of claim 93, further comprising a point of access positioned to provide access to the interior space after the container has experienced a civilly-catastrophic event.

104. The container of claim 103, wherein the point of access includes a locking mechanism.

105. The container of claim 104, wherein the locking mechanism is unlocked through at least one of: biometrics; an identification card; a still image; visual confirmation; an admission card; a password; a pass code; voice print; words; a transmission.

106. The container of claim 104, wherein the locking mechanism is unlocked from a location remote from the container using a wireless transmission.

107. The container of claim 93, wherein the mechanical securing device includes the application of at least one of: bolts, screws, chains, cement, anchors, nails, adhesive, bands, straps, cables, caissons, rebar, stakes, tether, a combination thereof.

108. The container of claim 107, wherein the mechanical securing device include a first end of the tether attached to the container, an anchor driven into a ground surface, and a second end of the tether attached to the anchor.

109. The container of claim 108, wherein the container has a positive buoyancy and the tether has a length sufficient to permit the container to float on a body of water.

110. The container of claim 109, further comprising at least one deployment mechanism to apply the mechanical securing device in order to secure the container at the second location.

111. The container of claim 93, wherein the container is configured and arranged with positive buoyancy such that the container will float in a liquid.

112. The container of claim 93, wherein the container comprises fireproof material.

113. The container of claim 93, wherein the container is configured and arranged to be submersible.

114. The container of claim 93, wherein the container includes wheels upon which the container can be rolled.

115. The container of claim 114, wherein the wheels are arranged and configured to be removed from the container.

116. The container of claim 93, wherein the container comprising a power source.

117. The container of claim 116, wherein the power generator includes at least one of: a wind-based power generator; a photonically-based power generator; a fluid-based power generator; a thermo-electric power generator; a stored-energy power generator.

118. The container of claim 93, wherein the interior space comprises a plurality of units for segregating items stored therein.

119. The container of claim 93, wherein the container includes a separation device such that the container can be divided into a plurality of containers.

120. The method of claim 93, wherein the interior space further comprises accommodations for one or more people including at least one of: sleeping accommodations; food preparation facilities, personal hygiene facilities; sitting accommodations; sanitation facilities.

121. The method of claim 93, wherein at least a portion of an outer surface of the container comprises an indicia rendering the container visible.

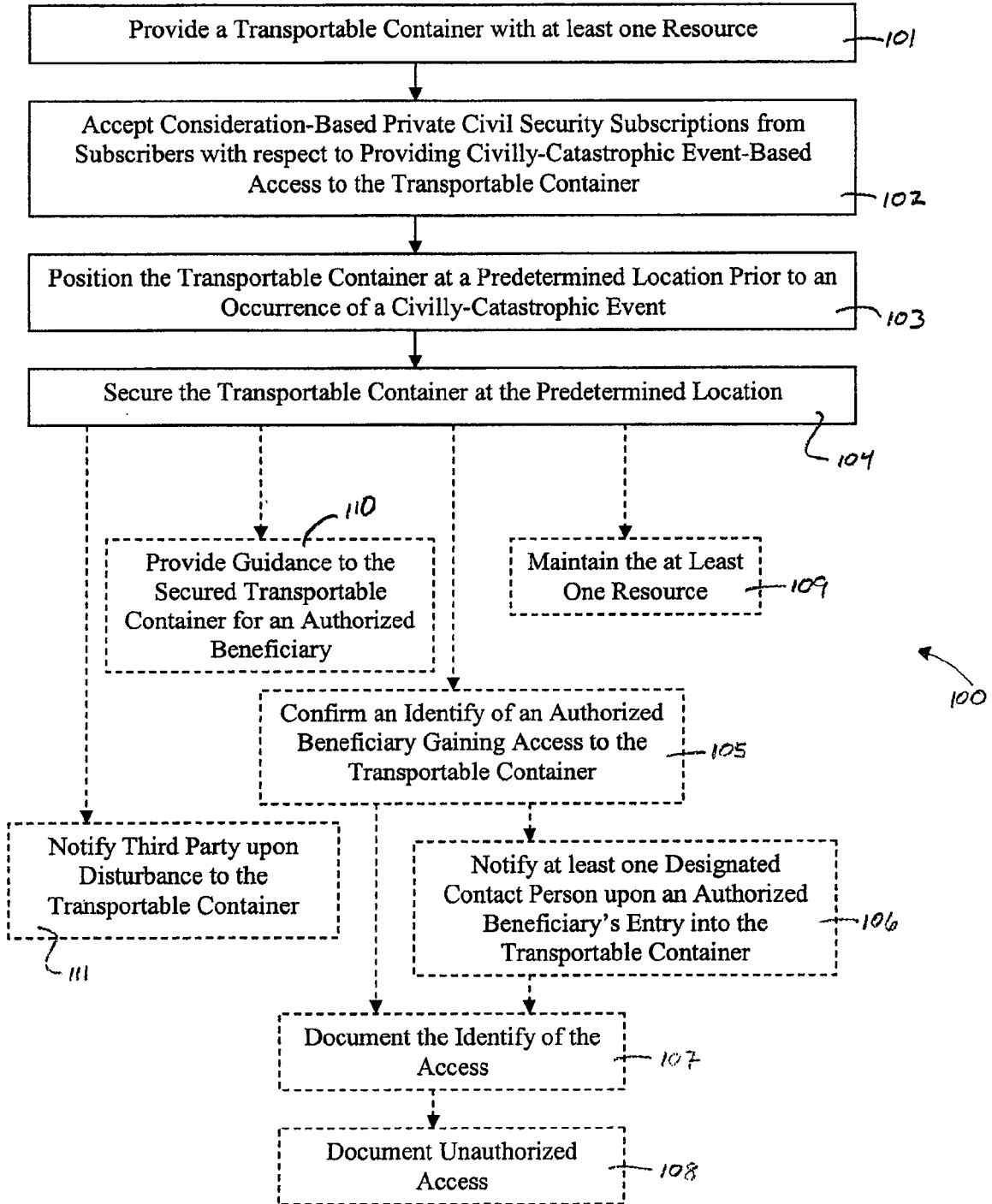

FIG. 1

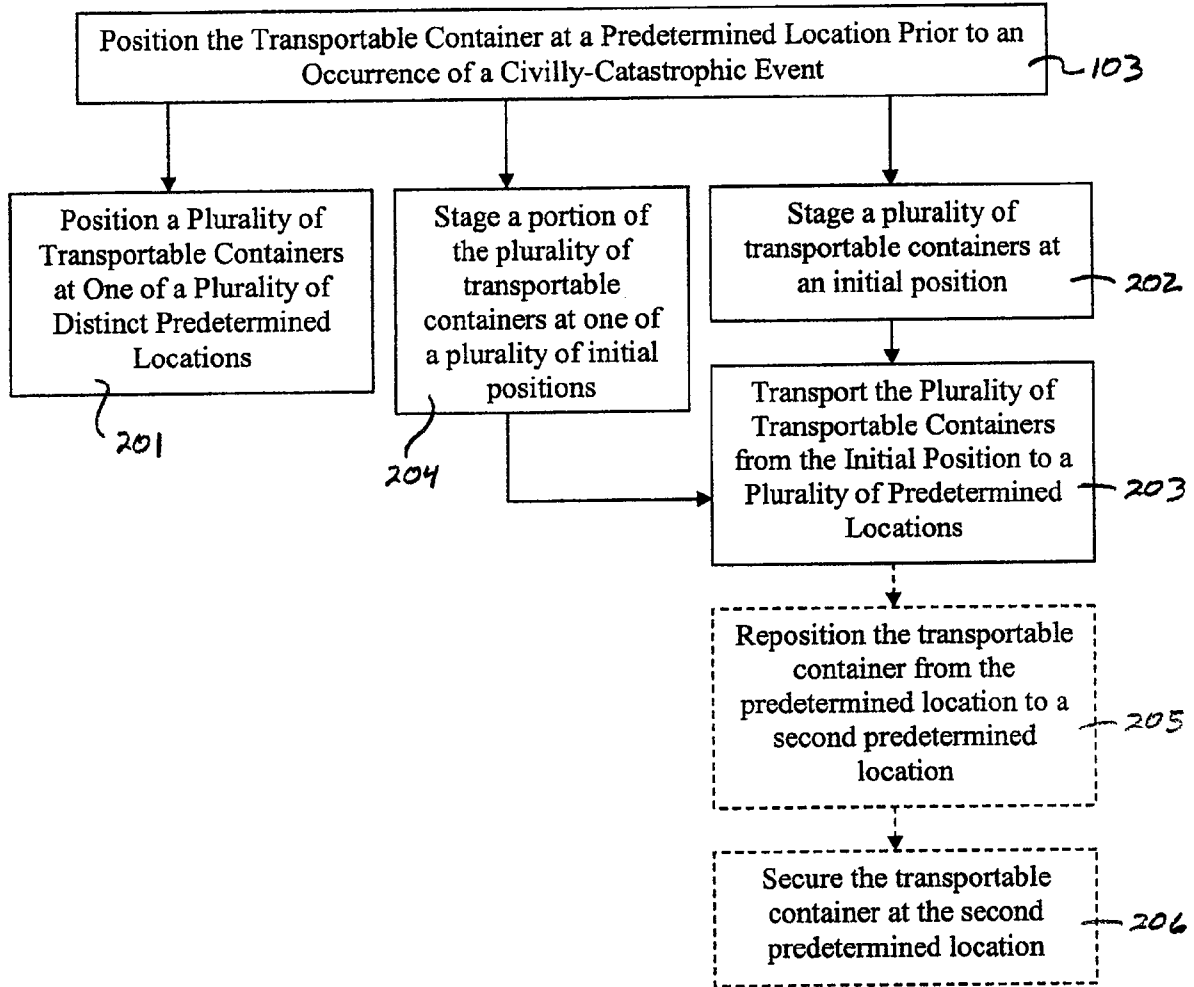

FIG. 2

3/8

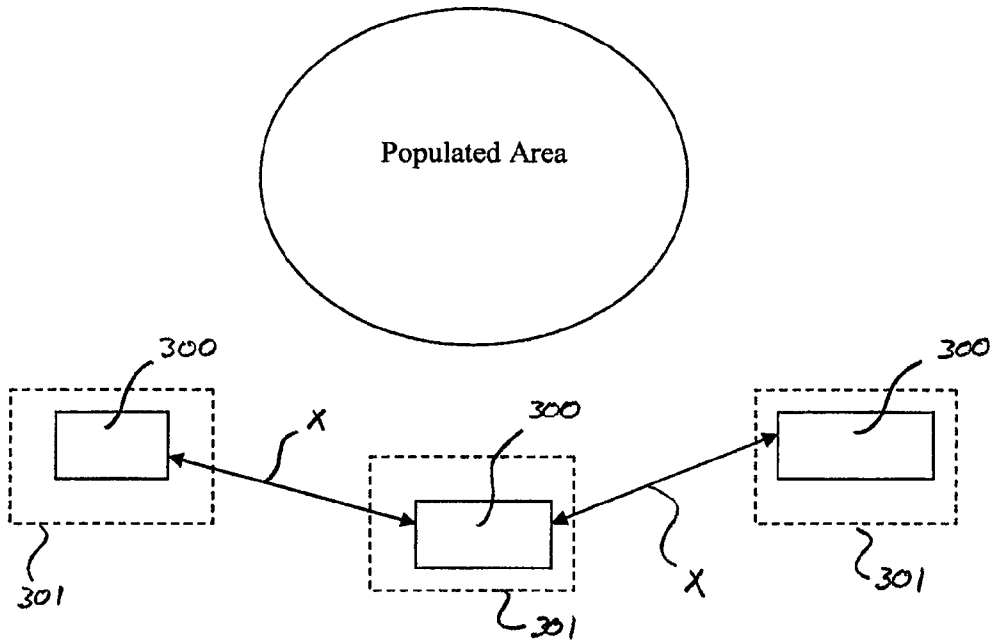

FIG. 3

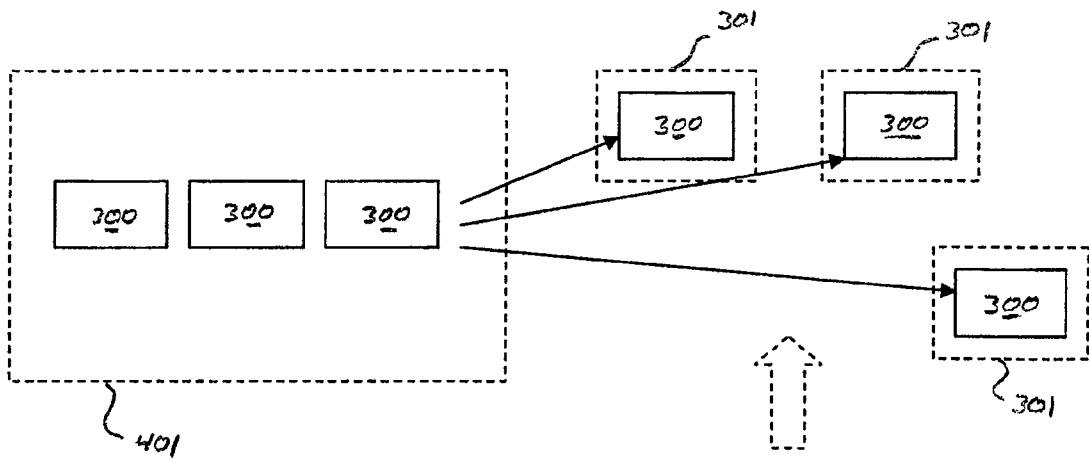
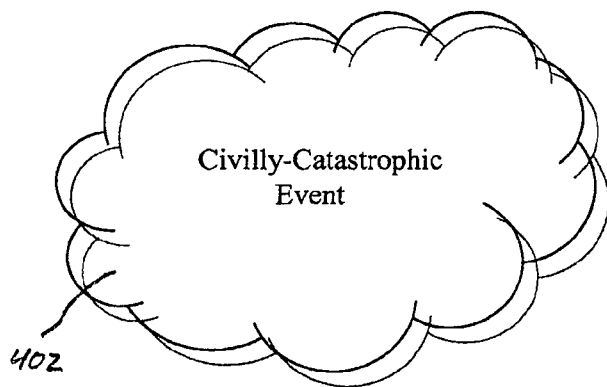

FIG. 4



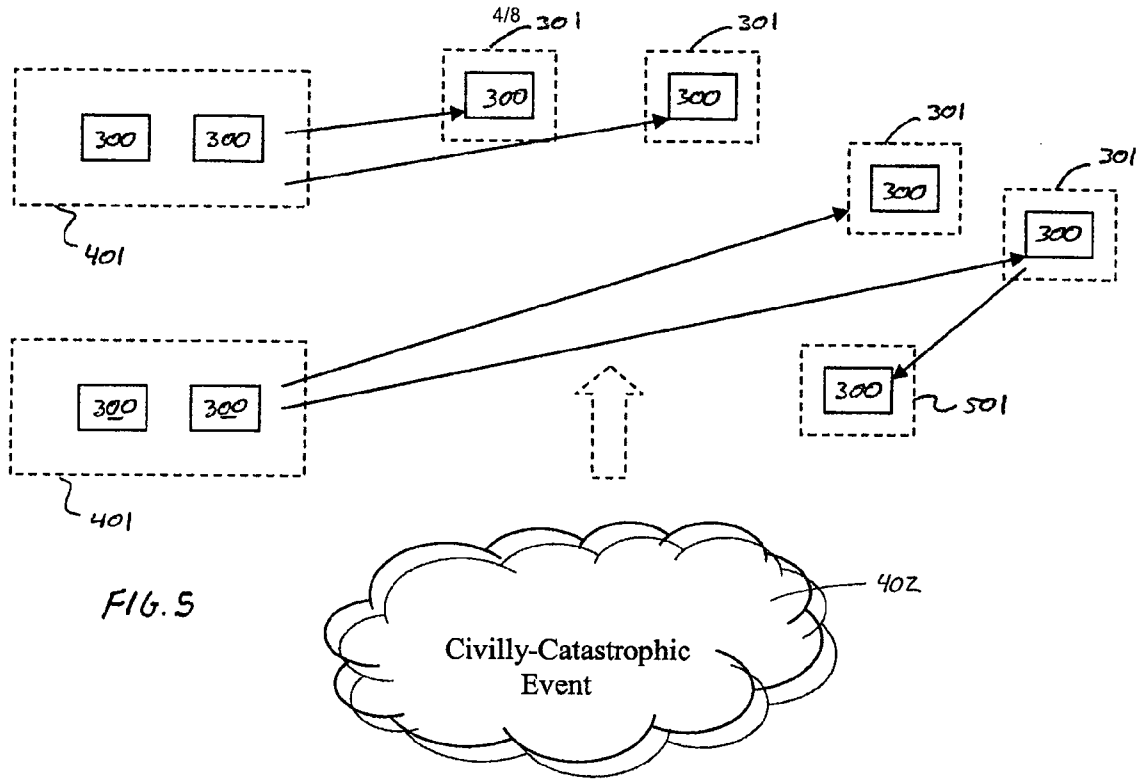

FIG. 5

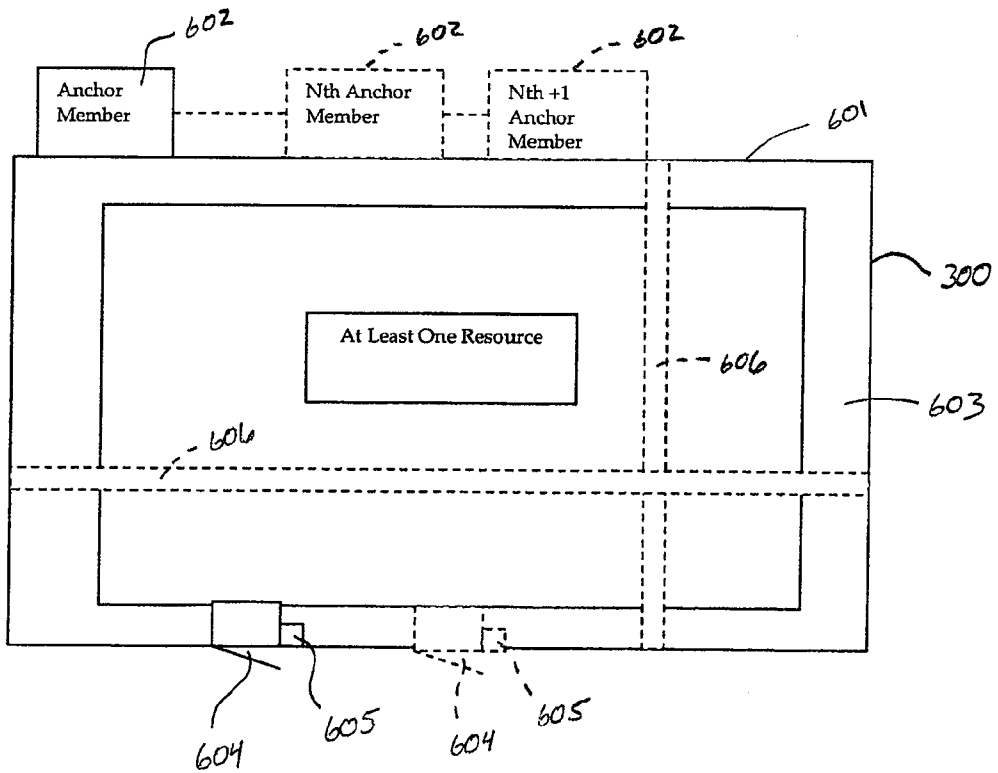
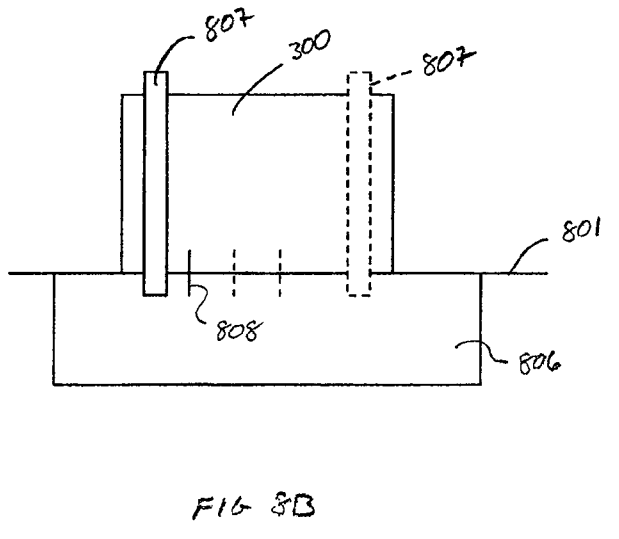
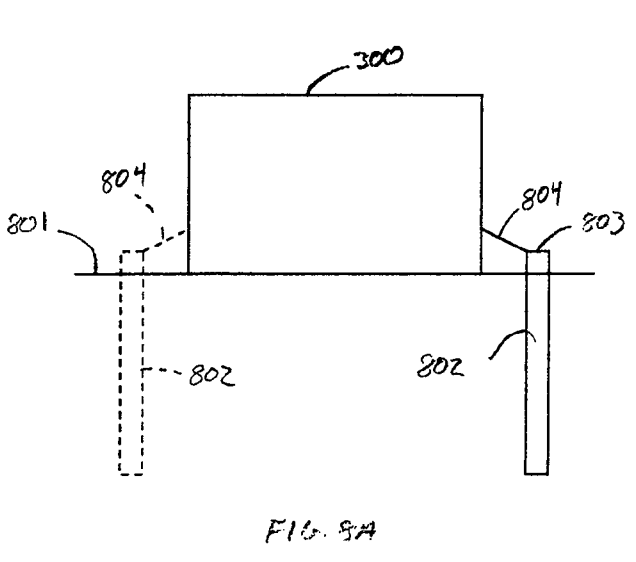
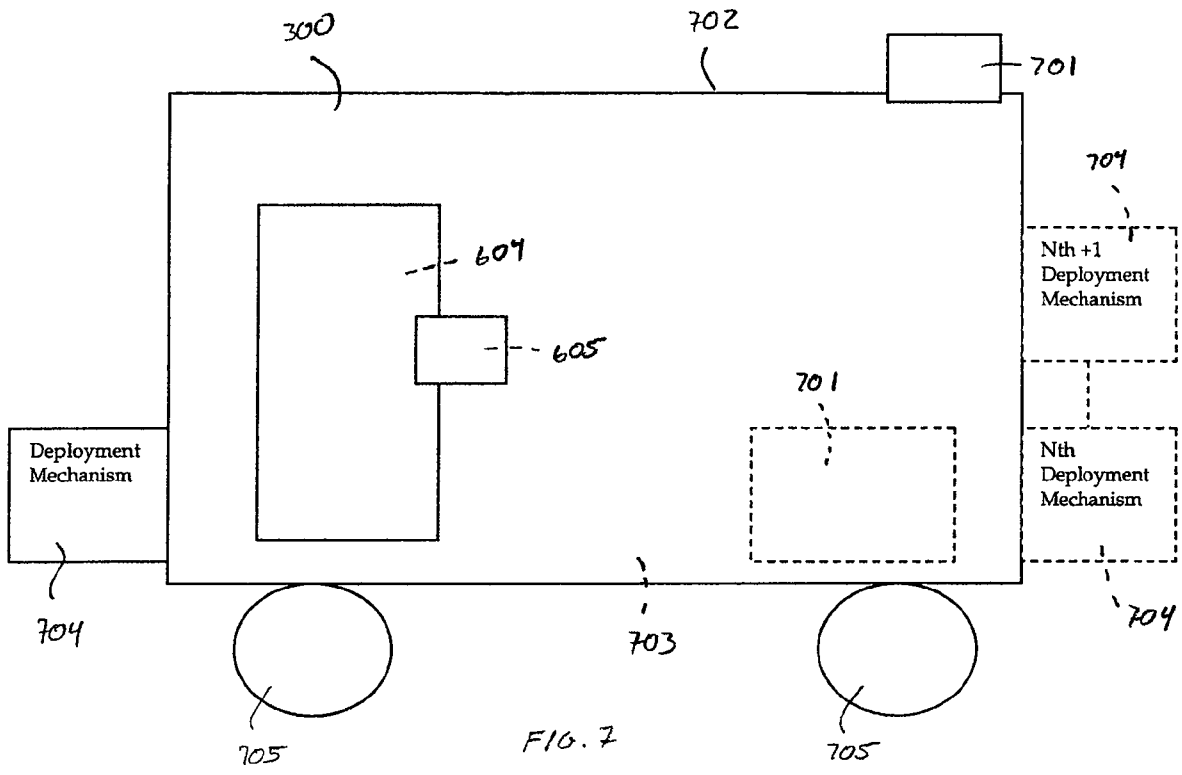

FIG. 6



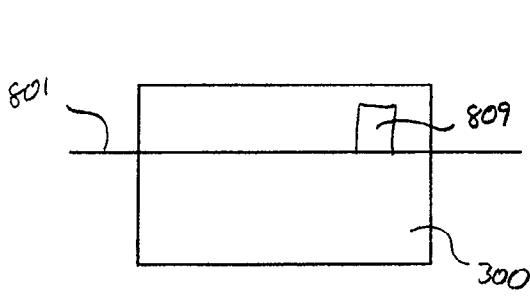

FIG. 8C

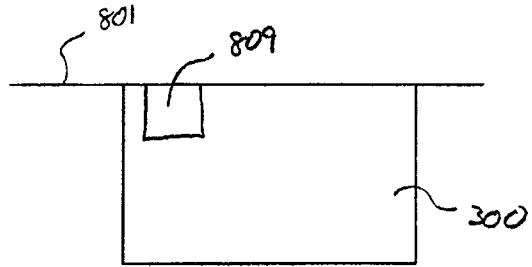

FIG. 8D

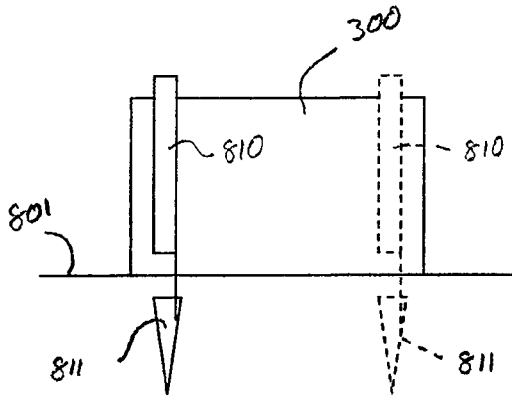

FIG. 8E

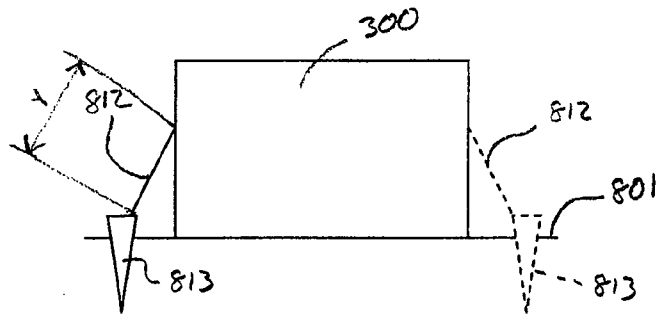

FIG. 8F

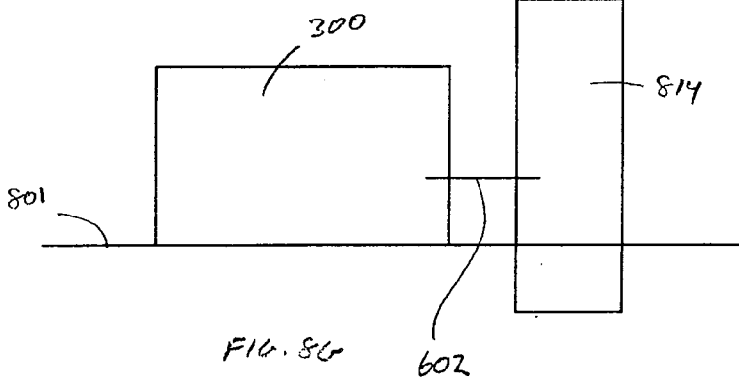

FIG. 8G

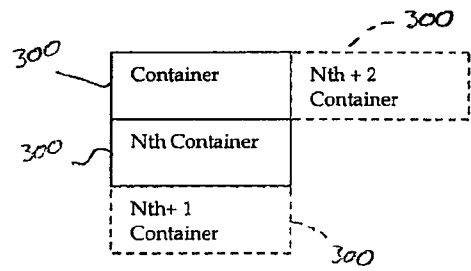

FIG. 8H

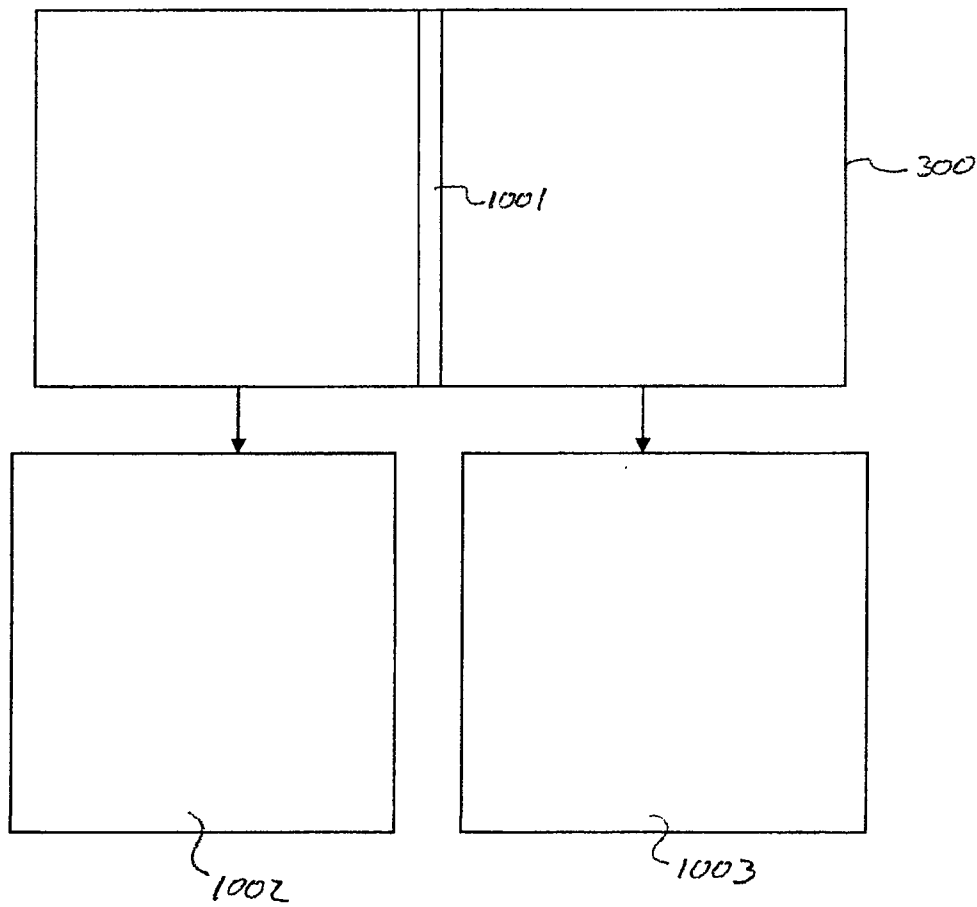
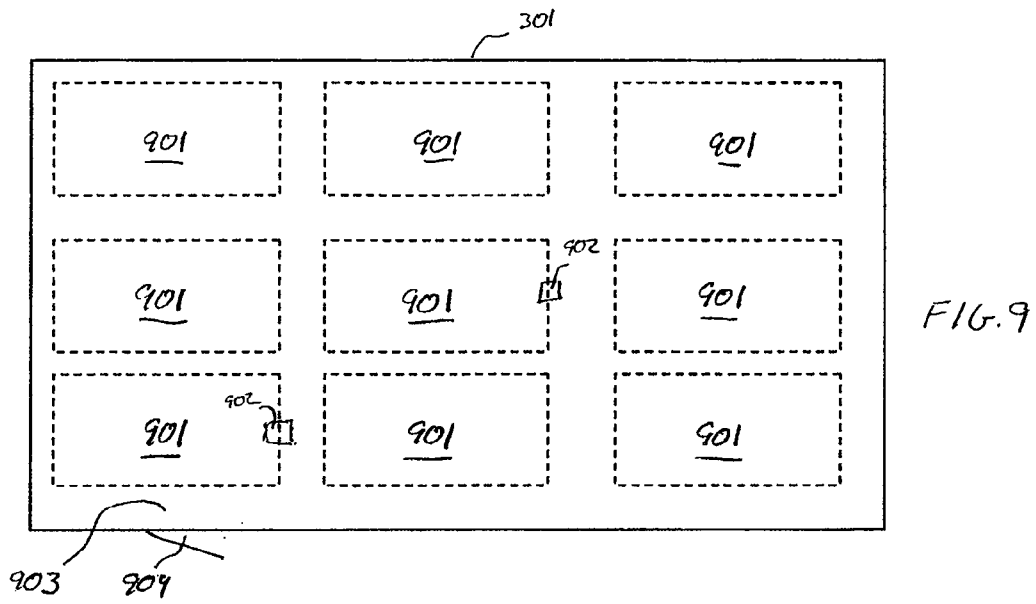

FIG. 10

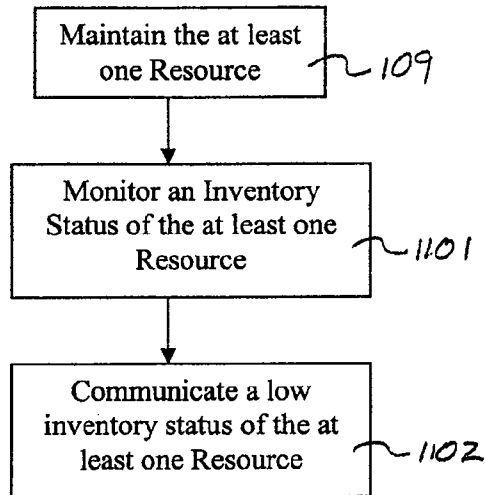

FIG. 11