

(19)



(11)

EP 2 985 239 B1

(12)

EUROPEAN PATENT SPECIFICATION

(45) Date of publication and mention
of the grant of the patent:
04.10.2017 Bulletin 2017/40

(51) Int Cl.:
B65D 85/10 (2006.01)

(21) Application number: **14180824.6**

(22) Date of filing: **13.08.2014**

(54) Child-resistant smoking article package with safety label

Kindersichere Rauchartikelverpackung mit Sicherheitsetikett

Emballage d'article à fumer avec protection contre les enfants avec étiquette de sécurité

(84) Designated Contracting States:
**AL AT BE BG CH CY CZ DE DK EE ES FI FR GB
GR HR HU IE IS IT LI LT LU LV MC MK MT NL NO
PL PT RO RS SE SI SK SM TR**

(43) Date of publication of application:
17.02.2016 Bulletin 2016/07

(73) Proprietor: **Fontem Holdings 1 B.V.**
1083 HN Amsterdam (NL)

(72) Inventor: **Rehders, Thorben**
22761 Hamburg (DE)

(74) Representative: **Gulde & Partner**
Patent- und Rechtsanwaltskanzlei mbB
Wallstraße 58/59
10179 Berlin (DE)

(56) References cited:
GB-A- 2 493 905 US-A1- 2009 014 350

EP 2 985 239 B1

Note: Within nine months of the publication of the mention of the grant of the European patent in the European Patent Bulletin, any person may give notice to the European Patent Office of opposition to that patent, in accordance with the Implementing Regulations. Notice of opposition shall not be deemed to have been filed until the opposition fee has been paid. (Art. 99(1) European Patent Convention).

Description

[0001] Child-resistant packages are well known in the field of medicaments. The regulations for a package to be declared "child-resistant" or "child-safe" are defined by different international norms and standards. These regulations require that a package would have to successfully undergo a number of test with actual groups of children in order to be officially declared child-resistant. In general, different safety elements are provided on a package which aim to delay the time until an unauthorised person, for instance a child, is able to open the package. This extra time should allow an authorized person to interfere with the unauthorized person before opening of the package is completed. Thus, the term "child-resistant package" like it is used in the present application is to be understood as referring to a package which exhibits certain features for delaying access to the interior of the package. GB 2493905 A discloses a re-sealable temper-evident label for sealing a package with first and second packaging portions, according to the preamble of claim 1.

SUMMARY OF THE INVENTION

[0002] In one aspect of the invention, a child-resistant smoking article package is provided comprising a container configured to contain smoking articles therein and a cap for closing an opening of the container. The cap is provided with a lower edge, which contacts the container in a closed state of the package and which is separated from the container in an open state of the package. A safety label is further provided on the package. The safety label comprises a base layer bonded to the package and comprises a first predetermined breaking point area of the base layer covering at least a part of the lower edge of the cap. Further provided is an at least partly removable intermediate layer covering at least a part of the first predetermined breaking point area of the base layer. An at least partly removable top layer is further provided covering the base layer with the intermediate layer thereon and having a second predetermined breaking point area of the at least partly removable top layer.

[0003] The inventive safety label delays access to the interior of the package and in addition avoids an accidental opening of the package.

[0004] The characteristics, features and advantages of this invention and the manner in which they are obtained as described above, will become more apparent and be more clearly understood in connection with the following description of exemplary embodiments, which are explained with reference to the accompanied drawings.

BRIEF DESCRIPTION OF THE DRAWINGS

[0005] The drawings show in

Fig. 1 a front view of a state of the art package

in a first embodiment,

- Fig. 2 a front view of a state of the art package in a closed state according to a second embodiment,
- Fig. 3 a side view of the package of Fig. 2 in an open state,
- Figs. 4 to 6 an assembling process of the safety label according to an embodiment of the invention,
- Fig. 7 an inventive package with a safety label attached thereto,
- Figs. 8 to 11 an opening process of the package according to an embodiment of the invention, and
- Fig. 12 a schematic view of a front, bottom, and back surface of an inventive package in an unfolded state with a safety label of Fig. 9 thereon.

DETAILED DESCRIPTION OF THE DRAWINGS

[0006] Figs. 1 to Fig. 3 show state of the art packages 100. The package 100 according to the state of the art and also throughout the invention may have the form of a parallelepiped with a front and a back surface, two side surfaces and a top and a bottom surface. The package 100 may preferably be made from paper or from plastic. However, other shapes and materials are possible and the package 100 is neither limited to the shape of a parallelepiped nor to plastic or paper material. As shown in Figs. 1-3, a package 100 comprises a container 110 configured to have an accommodation space therein for accommodating a product therein, like a smoking article or an electronic smoking article.

[0007] The container 100 has an opening, here the top surface of the container 100, enclosed by the front, back and two side surfaces of the container 100. The package 100 further comprises a cap 120 connected to the container 110 in a closed state of the package 100, preferably hingedly connected or fully detachably connected. The cap 120 is configured to close the opening of the container 110. A lower edge 122 of the cap 120 contacts the container 110 in a closed state of the package 100 and is separated from the container 110 in an open state of the package 100. Thus, the cap 120 allows access to the interior of the container 110. The lower edge 122 could also be called an opening edge of the package 100.

[0008] In the embodiment of Fig. 1, the pack 100 comprises a cap 120 hingedly connected to the container 110, where both the cap 120 and the container 110 each have front, rear and a pair of side panels or surfaces. The hinged connection 140 between the cap 120 and the

container 110 in Fig. 1 is on the left side of the package 100. Such packages 100 are sometimes called "zippos" since they open like certain types of cigarette lighters called "zippos" (RTM). Figs. 2 and 3 show another embodiment of a package 100 in a front and a side view. Here, said hinge connection 140 may be defined by a fold between the rear surface of the cap 120 and the rear surface of the container 110. However, the cap 120 could also be provided fully separable from the container 110.

[0009] Figs. 4 to 6 show an assembling process of a safety label 1 according to an embodiment of the invention. The safety label 1 is usually assembled without the respective inventive package 100 and is transferred onto the package in an assembled state of the safety label 1.

[0010] A safety label 1 as shown exemplarily in Figs. 4 to 6 comprises a base layer 10 as shown in the middle of Fig. 4, an intermediate layer 20 as shown in the left of Fig. 4, and a top layer 30 on the right of Fig. 4. In order to gain access to an interior of an inventive package 100 provided with a safety label 1, first the top layer 30 needs to be peeled- or lifted-off from the intermediate layer 20, the intermediate layer 20 needs to be peeled-off from the base layer 10 and the base layer 10 needs to be disintegrated or separated into at least two parts.

[0011] The base layer 10 is the bottom layer of the safety label 1, i.e. the layer to be attached to a package 100, preferably directly onto a package 100. The intermediate layer 20 is placed on, preferably directly on the base layer 10. The top layer 30 is placed on, preferably directly on the intermediate layer 20 and, depending on the size of the intermediate layer 20, may also be placed on, preferably directly on the base layer 10.

[0012] The sizes of the different layers and their relation to each other as presented in the following embodiments are only to be viewed as non restrictive examples. The top layer 30 is sized such that it covers the intermediate layer 20, preferably fully covers the intermediate layer 20. The intermediate layer 20 may have the same size as the base layer 10. In the non restrictive embodiments shown in the following, the intermediate layer 20 has a smaller size and only partly covers the base layer 10. The base layer 10 and the top layer 30 may have the same width, or the same height, or the same height and width as shown in Figs. 4 to 6. Advantageously, the top layer 30 has the same size as the base layer 10. Consequently, the top layer 30 is provided to fully cover the base layer 10 hiding the layered structure of the label 1 and making an access to a package with the safety label 1 thereon more difficult.

[0013] All layers 10, 20, 30 may comprise an adhesive layer attached to their back sides for adhesively bonding the base layer 10 to a package, the intermediate layer 20 to the base layer 10 and the top layer 30 to the intermediate layer 20 or the intermediate layer 20 and the base layer 10, respectively. An adhesive layer allows easy assembly and disassembly of the safety label 1. However, the bonding strength of the individual layers

with respect to each other may differ. Also, the bonding strength of an adhesive within a certain layer may vary, e.g. the adhesive itself may vary throughout a layer. The different bonding strengths may make it easier to peel-off certain parts of a layer, while others are more difficult to be peeled-off. Throughout the following, a region, where an adhesive exhibits less bonding strength than in other regions of the respectively layer, this may be called to form a means for reducing the adhesive force of a layer.

Further, it may be desirable to provide the base layer 10 with a very strong adhesive which would make it impossible to peel-off the base layer 10 from a package intact.

[0014] The base layer 10 comprises a first predetermined breaking point area 12. In general, a predetermined breaking point area as described herein is any area of a layer which leads to a disintegration of an originally integral structure of a layer upon exertion of a force in a certain direction thereon, while the same force will not lead to a disintegration of the layer in another area of the layer.

[0015] The first breaking point area 12 is designed to disintegrate the base layer 10 into two separate parts upon exertion of a force on the first breaking point area 12. The top layer 30 comprises a second predetermined breaking point area 32. The second predetermined breaking point area 32 is designed to disintegrate the top layer 30 into at least two separate parts 34, 36 upon exertion of a force on the second breaking point area 32.

[0016] The intermediate layer 20 is provided to removably cover at least a part of the first predetermined breaking point area 12 of the base layer 10. This is shown in Fig. 5. The intermediate layer 20 is placed to fully cover the height of the first predetermined breaking point area 12 such that also a region below and above the first predetermined breaking point area 12 of the base layer 10 is contacted by the intermediate layer 20. It may optionally also cover the length of the first predetermined breaking point area 12. Thus, by covering the height of the first predetermined breaking point area 12, it is not possible to break the first predetermined breaking point area 12 entirely without removal of the intermediate layer 20.

[0017] The inventive three-layer structure of the safety label 1 including the different predetermined breaking point areas 12, 32 provide obstacles and distractions before access to a package 100 may be gained. As a consequence, it will not be readily ascertainable, where to start an opening process of the package 100. The obstacles and distractions are not constructed such that it is impossible to open the package 100. They are provided such that an authorized person is able to open the package in sufficient time and once he learned the process of opening the package 100, would be able to gain access to the interior of the package 100 without undue burden. An access of an unauthorized person, however, is supposed to be delayed in time. Unauthorized persons may be children.

[0018] The top layer 30 may be at least partly transparent. In a preferred embodiment, the top layer 30 is

fully transparent. In this way one may directly view the base layer 10 and the first determined breaking point area 12 without having the actual ability to interfere with said first determined breaking point area 12 or with the base layer 10 at all, since they are covered by the top layer 30. Thus, a person wishing to open the package may be directed to interfere with the first determined breaking point area 12, while he will actually learn that he has no direct access to this area 12. The same holds for the intermediate layer 20. If the top layer 30 is transparent, a person wishing to open the package may directly view the intermediate layer 20 and may try to interfere with the intermediate layer 20 while having no direct access to the intermediate layer 20. This would delay an access to the interior of the package 100.

[0019] Also the intermediate layer 20 may be fully transparent. This would make it more difficult to view the intermediate layer 20 on top of the base layer 10. In a preferred embodiment as shown in Figs. 4 to 6, however, the intermediate layer 20 may have a transparent body 21 and an at least partially non-transparent visual element 22. The visual element 22 would be provided in the periphery of the lower edge 122 of the cap 120, i.e. in the region of the first predetermined breaking point area 12. The visual element 22 would provide another distraction to a person wishing to open the package 100 since he may be tempted to start the opening process on the visual element formed above the lower edge 122 of the cap 120. The visual element 22 could be an arrow or a triangle or a point or a circle or a dotted line. The visual element 22 is provided to direct a person wishing to open the package 100 to the visual element 22. However, with the top layer 30 to be intact, no access would be possible. Also, after the top layer 30 is peeled-off, the visual element 22 may direct said person away from a border or corner of the intermediate layer 20, which would have to be accessed in order to peel-off the intermediate layer 20. Thus, starting from the border or corner of the intermediate layer 20, the whole layer would be lifted or peeled-off from the base layer 10, but the peel-off process could not be initiated by starting from the visual element 22.

[0020] Fig. 4 shows the three layers 10, 20, 30 of the safety label 1 next to each other. In Fig. 5 the intermediate layer 20 is bonded to the base layer 10 such that it covers the height of the first predetermined breaking point area 12. In a second assembly step, the top layer 30 is now placed on the intermediate layer 20 and - in the area where the intermediate layer 20 is not provided - the base layer 10. The assembled safety label 1 is shown in Fig. 6. The top layer 30 here fully covers the base layer 10 and the intermediate layer 20.

[0021] Fig. 7 shows a front view of an inventive package 100 with a safety label 1 thereon. The safety label 1 is the same as in Fig. 6, but additionally comprises an optional label element 18 only shown in Fig. 7. The label element 18 may include a label of the product enclosed in the package 100. In one preferred embodiment, the

label element 18 and the intermediate layer 20 may have the same shape. This may provide additional distraction since a user wishing to open the package 100 may view the intermediate layer to be a label of the product, but not an element which needs to be removed to gain access to the package 100.

[0022] As shown in Fig. 7, the base layer 10 comprises a first part 14 above the first predetermined breaking point area 12 which is bonded to the cap 120, preferably adhesively bonded to the cap 120, and a second part 16 below the first predetermined breaking point area 12 which is bonded to the container 110, preferably adhesively bonded. The first and second parts 14, 16 are detachably connected to each other via the first predetermined breaking point area 12. In other words, the continuous base layer 10 is arranged on the cap 120 and also on the container 110 and thereby fixes the cap 120 to the container 120 providing child-safe protection of the package 100.

[0023] The first predetermined breaking point area 12 as exemplarily shown in Figs. 4 to 7 comprises at least one disruption or perforation line, preferably multiple disruption or perforation lines. The provision of multiple disruption or perforation lines allows for tolerance during assembly of the base layer 10. Consequently, the first predetermined breaking point area 12 would still cover a part of the lower edge 122 of the cap 120 even if it is arranged with a slight vertical offset onto different packages 100. This could be achieved for any means of breaking incorporated into the first predetermined breaking point areas 12 by simply providing multiple means of breaking, like the above perforation lines, perpendicular to the lower edge 122 of the cap 120.

[0024] The second predetermined breaking point area 32 may be provided directly on the base layer 10, or depending on the size of the intermediate layer 20, on the intermediate layer 20. The second predetermined breaking point area 32 of the top layer 30 may comprise a peel-off element 33 like a flap or strip adapted to be peeled-off from the base layer 10 as shown in Fig. 8. The upper and lower sides of the peel-off element 33 may each comprises a perforation line to break the bond between the peel-off element 33 and the first and second parts 34, 36 of the top layer 30. Now, in order to gain access to the interior of the package 100, one would first have to interfere with the second predetermined breaking point area 32. In the shown embodiment, one would have to grab the peel-off element 33 in the top layer 30 from a side surface of the safety label 1 and pull it off the base layer 10 or the intermediate layer 20 by exerting a force on the edge of the peel-off element 33 in a width direction of the package 100 as shown in Fig. 8.

[0025] Fig. 9 shows the package 100 after the peel-off element 33 is peeled-off. The first and second parts 34, 36 of the top layer 30 remain on the base layer 10 or the intermediate layer 20, respectively. The first top layer part 14 may optionally comprise a means 38 for reducing the adhesive force of the top layer 30 at its periphery, for

instance at a corner. This corner may now be accessible for a user. The location where the means 38 for reducing the adhesive force of the top layer 30 is provided determines where one may get easy access to the first top layer part 34 for peeling-off the first top layer part 34 from the underlying structure. However, instead of having a means 38 for reducing the adhesive force of the top layer 30, a part of the first part 34 of the top layer 30 may comprise an element 39 indicating a preferred access point to the first part 34. This element 39 may just be a coloured region as indicated in Fig. 9 or may comprise text. Also, both elements, a means 38 for reducing the adhesive force of the top layer 30 and an element 39 for indicating a preferred access point may be provided together at the same location.

[0026] Means 38 or elements 39 may also form part of the first and/or second predetermined breaking point areas 12, 32 or may be provided in general somewhere along a periphery of the base, intermediate or top layers 10, 20, 30.

[0027] In one embodiment, in order to delay access to the package 100, one may have to exert a force on the first part 34 of the top layer 30 in a different direction in comparison to the force necessary to peel-off the second predetermined breaking point area 32. In the shown embodiment, a diagonal force would have to be applied.

[0028] Fig. 10 shows a front view of the package 100 with the safety label 1 after the first part 34 of the top layer 30 has been peeled-off. Here, also the second part 36 has been peeled-off. However, the second part 36 may also remain on the package 100. The first part 34 does not need to be peeled-off completely but only in so far that the intermediate layer 20 becomes fully accessible and the second predetermined breaking point area 12 would not be covered anymore by the top layer 30.

[0029] In the next step of opening the package 100, the intermediate layer 20 has to be peeled-off from the base layer 10, specifically from the first predetermined breaking point area 12 of the base layer 10. This could be done by grabbing a corner or border of the intermediate layer 20 and starting to peel-off the intermediate layer 20 from that corner or border. However, the intermediate layer 20 may additionally comprise a peel-off element or protrusion for grabbing or may also have a means for reducing the adhesive force or may comprise an element 39 for indicating where to start peeling-off the intermediate layer 20.

[0030] After peel-off of the intermediate layer 20, the first predetermined breaking point area 12 becomes fully accessible for manipulation. In the last step of the opening process of the package 100, one would have to pull the cap 120 and the first predetermined breaking point area 12 would break. The first predetermined breaking point area 12 in Fig. 11 comprises a number of perforations or perforations lines or disruption lines. If a force is exerted onto the first predetermined breaking point area 12, the base layer 10 is torn apart at the first predetermined breaking point area 12. A first part 14 above the

first predetermined breaking point area 12 remains bonded to the cap 120, a second part 16 below the first predetermined breaking point area 12 remains bonded to the container 110.

[0031] Of course, as discussed previously in framework of Figs. 2 and 3, the cap 120 may also separate differently from the container 110. The first predetermined breaking point area 12 is provided on the line of separation or opening, here the lower edge 122 of the cap 120 and breaks upon exertion of a force. The force may act in the plane of the base layer 10.

[0032] In another embodiment, the inventive package 100 may comprise at least two safety labels 1, for instance one safety label 1 on a front surface of the package, and one on a back surface of the package 100. In yet another embodiment, one of the two safety labels 1 may be provided on a side surface of the package 100, and the other one may be provided on an opposing side surface of the package 100. Thus, in order to open the package 100, the safety label 1 would have to be removed twice which further increases a delay before an access to the interior of the package 100 is possible.

[0033] In a further embodiment, a single safety label 1 may be provided to extend on at least two different surfaces of the package 100, like a front surface and a side surface of the package. Since two surfaces of the package 100 are involved, the opening process becomes even more difficult further increasing the delay time. For instance, if the second predetermined breaking point area 32 is a flap or strip, the flap or strip needs to be moved across two different surfaces making the opening process more complex.

[0034] In another embodiment as shown in Fig. 12, a single safety label 1 may extend across a front surface 102, a back surface 106, and a bottom surface 104 of the package 100. Fig. 12 shows these three surfaces of the package in an unfolded state, omitting the side surfaces of the package 100 for simplicity. In such an embodiment, the safety label 1 may comprise two intermediate layers 20, one provided to cover at least partly the lower edge 122 of the cap 120 on a front surface 102 of the package 100, and one provided to cover at least partly the lower edge 122 of the cap 120 on a back surface 106 of the package 100. The second predetermined breaking point area 12 may then be provided on the bottom surface 104 of the package 100, or on the front surface 102, or on the back surface 106. However, it is also possible to provide two second predetermined breaking point areas 32 on different surfaces of the package 100 covered by the safety label 1, preferably on the front 102 and on the back surface 106 of the package 100 further delaying an access.

[0035] Here, in total three faces of the package 100 are involved in order gain access resulting in a more complex access process. The three surfaces could also be represented by the omitted two side surfaces adjacent to the front surface 102 and the front surface 102.

[0036] In all the embodiments of the present invention

it may also be possible to use more than one first or second predetermined breaking point areas 12, 32 or more than one intermediate layer 20. Further, additional layers may be provided.

[0037] For instance, if a single safety label 1 extends on different surfaces, one second predetermined breaking point area 32 may be arranged on a first surface, one on a second, different surface. A second predetermined breaking point area 32 may have to be opened in a different direction with respect to the other second predetermined breaking point area 32. In one embodiment, one second predetermined breaking point area 32 may be provided on a front surface of the package 100, one on a side surface of the package 100. The one second predetermined breaking point area 32 on the side surface may be opened from the back to the front, the other second predetermined breaking point area 32 may have to be opened from left to right.

[0038] Also, if two safety labels 1 are provided on different surfaces, like the front and the back surface, they may be provided to be opened in opposing directions.

[0039] The described safety label 1 only provides once a delay in opening the package 100. The package 100 may contain only a single product, for instance a single smoking article, like a single electronic smoking article.

[0040] While this invention has been described in connection with what is presently considered to be practical exemplary embodiments, it is to be understood that the invention is not limited to the disclosed embodiments, but, on the contrary, is intended to cover various modifications and equivalent arrangements included within the scope of the appended claims.

Claims

1. A child-resistant smoking article package (100) comprising:

a container (110) configured to contain smoking articles therein,
 a cap (120) for closing an opening of the container (110) and having a lower edge (122) contacting the container (110) in a closed state of the package (100) and separated from the container (110) in an open state of the package (100), and
 a safety label (1) provided on the package (100), wherein the safety label (1) comprises:

a base layer (10) bonded to the package (100) and comprising a first predetermined breaking point area (12) of the base layer (10) covering at least a part of the lower edge (122) of the cap (120), **characterised in that** it further comprises, an at least partly removable intermediate layer (20) covering at least a part of the first predetermined

breaking point area (12) of the base layer (10), and
 an at least partly removable top layer (30) covering the base layer (10) with the intermediate layer (20) thereon and having a second predetermined breaking point area (32) of the at least partly removable top layer (30).

2. The package (100) of claim 1, wherein the top layer (30) is at least partly transparent, preferably fully transparent.
3. The package (100) of claim 1 or 2, wherein the base layer (10) comprises a first part (14) adhesively fixed to the cap (120), a second part (16) adhesively fixed to the container (110), the first and second part (14, 16) being detachably connected to each other via the first predetermined breaking point area (12).
4. The package (100) of any of the previous claims, wherein the top layer (30) comprises a first part (34) and a second part (36) being detachably connected to each other via the second predetermined breaking point area (32).
5. The package (100) of any of the previous claims, wherein the first predetermined breaking point area (12) comprises at least one disruption or perforation line, preferably multiple disruption or perforation lines.
6. The package (100) of claim 4 or claim 5 wherein the first predetermined breaking point area (12) of the base layer (10) is covered by either the first part (34) or the second part (36) of the top layer (30) when the first part (34) and the second part (36) of the top layer (30) are connected to each other via the second predetermined breaking point area (32).
7. The package (100) of any of the previous claims, wherein the second predetermined breaking point area (32) of the top layer (30) is bonded to the base layer (10).
8. The package (100) of any of the previous claims, wherein the second predetermined breaking point area (32) of the top layer (10) comprises a flap adapted to be peeled-off from the base layer (10).
9. The package (100) of any of the previous claims, wherein the top layer (30) comprises a means for reducing the adhesive force (38) of the top layer (30) with respect to the adhesive force of the remainder of the top layer (30), which becomes accessible after disruption of the second predetermined breaking point area (32).

10. The package (100) of any of the previous claims, wherein the intermediate layer (20) is fully transparent or comprises a transparent body and an at least partially non-transparent visual element (22).

5

11. The package (100) of any of the previous claims, wherein the base layer (10) further comprises a label element (18).

12. The package (100) of any of the previous claims, wherein the base layer (10) and the top layer (30) have the same width, or the same height, or the same height and width.

10

13. The package (100) of any of the previous claims, wherein two or more safety labels (1) are provided each safety label (1) being provided on a different surface of the package.

15

14. The package (100) of any of the previous claims, wherein the safety label (1) is provided to extend on at least two different surfaces of the package (100).

20

15. The package (100) of claim 14, wherein the safety label (1) extends across a front surface (102), a back surface (106), and a bottom surface (104) of the package (100).

25

16. The package (100) of claim 15, wherein the safety label (1) comprises two intermediate layers (20), one provided to cover at least partly the lower edge (122) of the cap (120) on a front surface (102) of the package (100), and one provided to cover at least partly the lower edge (122) of the cap (120) on a back surface (106) of the package (100).

30

35

17. The package (100) of claim 15 or 16, wherein the second predetermined breaking point area (32) is provided on the bottom surface (104) of the package (100).

40

18. The package (100) of claim 15 or 16, wherein two second predetermined breaking point areas (32) are provided on different surfaces of the package (100) covered by the label (1), preferably on the front and back surface (102, 106) of the package (100).

45

19. The package of any of the previous claims, wherein the base layer 10, the intermediate layer 20 and the top layer 30 comprise an adhesive layer on their back surfaces.

50

Patentansprüche

1. Kindersichere Rauchartikelverpackung (100), umfassend:

55

einen Behälter (110), der dazu gestaltet ist, darin Rauchartikel zu beinhalten, eine Kappe (120) zum Schließen einer Öffnung des Behälters (110) mit einer unteren Kante (122), die in einem geschlossenen Zustand der Verpackung (100) mit dem Behälter (110) in Kontakt steht und in einem offenen Zustand der Verpackung (100) vom Behälter (110) getrennt ist, und ein auf der Verpackung (100) bereitgestelltes Sicherheitsetikett (1), wobei das Sicherheitsetikett (1) Folgendes umfasst:

eine mit der Verpackung (100) verklebte Grundsicht (10), die einen ersten vorbestimmten Sollbruchstellenbereich (12) der Grundsicht (10) umfasst, der zumindest einen Teil der unteren Kante (122) der Kappe (120) bedeckt,

dadurch gekennzeichnet, dass sie ferner eine zumindest teilweise entfernbare Zwischenschicht (20), die zumindest einen Teil des ersten vorbestimmten Sollbruchstellenbereichs (12) der Grundsicht (10) bedeckt, und eine zumindest teilweise entfernbare Oberschicht (30), welche die Grundsicht (10) mit der Zwischenschicht (20) darauf bedeckt und einen zweiten vorbestimmten Sollbruchstellenbereich (32) der zumindest teilweise entfernbaren Oberschicht (30) aufweist, umfasst.

2. Verpackung (100) nach Anspruch 1, wobei die Oberschicht (30) zumindest teilweise transparent, vorzugsweise vollständig transparent ist.

3. Verpackung (100) nach Anspruch 1 oder 2, wobei die Grundsicht (10) einen haftend an der Kappe (120) befestigten ersten Teil (14) und einen haftend am Behälter (110) befestigten zweiten Teil (16) umfasst, wobei der erste und der zweite Teil (14, 16) über den ersten vorbestimmten Sollbruchstellenbereich (12) lösbar miteinander verbunden sind.

4. Verpackung (100) nach einem der vorangehenden Ansprüche, wobei die Oberschicht (30) einen ersten Teil (34) und einen zweiten Teil (36) umfasst, die über den zweiten vorbestimmten Sollbruchstellenbereich (32) lösbar miteinander verbunden sind.

5. Verpackung (100) nach einem der vorangehenden Ansprüche, wobei der erste vorbestimmte Sollbruchstellenbereich (12) zumindest eine Bruch- oder Perforationslinie, vorzugsweise mehrere Bruch- oder Perforationslinien, umfasst.

6. Verpackung (100) nach Anspruch 4 oder Anspruch 5, wobei der erste vorbestimmte Sollbruchstellenbe-

- reich (12) der Grundschrift (10) durch den ersten Teil (34) oder den zweiten Teil (36) der Oberschrift (30) bedeckt ist, wenn der erste Teil (34) und der zweite Teil (36) der Oberschrift (30) über den zweiten vorbestimmten Sollbruchstellenbereich (32) miteinander verbunden sind. 5
7. Verpackung (100) nach einem der vorangehenden Ansprüche, wobei der zweite vorbestimmte Sollbruchstellenbereich (32) der Oberschrift (30) mit der Grundschrift (10) verklebt ist. 10
8. Verpackung (100) nach einem der vorangehenden Ansprüche, wobei der zweite vorbestimmte Sollbruchstellenbereich (32) der Oberschrift (10) eine Lasche umfasst, die dafür geeignet ist, von der Grundschrift (10) abgezogen zu werden. 15
9. Verpackung (100) nach einem der vorangehenden Ansprüche, wobei die Oberschrift (30) ein Mittel zum Reduzieren der Haftkraft (38) der Oberschrift (30) gegenüber der Haftkraft des Rests der Oberschrift (30), die nach dem Aufbrechen des zweiten vorbestimmten Sollbruchstellenbereichs (32) zugänglich wird, umfasst. 20
10. Verpackung (100) nach einem der vorangehenden Ansprüche, wobei die Zwischenschicht (20) vollständig transparent ist oder einen transparenten Körper und ein zumindest teilweise nichttransparentes visuelles Element (22) umfasst. 25
11. Verpackung (100) nach einem der vorangehenden Ansprüche, wobei die Grundschrift (10) ferner ein Etikettelement (18) umfasst. 30
12. Verpackung (100) nach einem der vorangehenden Ansprüche, wobei die Grundschrift (10) und die Oberschrift (30) dieselbe Breite oder dieselbe Höhe oder dieselbe Höhe und Breite aufweisen. 35
13. Verpackung (100) nach einem der vorangehenden Ansprüche, wobei zwei oder mehr Sicherheitsetiketten (1) bereitgestellt sind, wobei jedes Sicherheitsetikett (1) auf einer unterschiedlichen Seite der Verpackung bereitgestellt ist. 40
14. Verpackung (100) nach einem der vorangehenden Ansprüche, wobei das Sicherheitsetikett (1) bereitgestellt ist, um sich auf zumindest zwei unterschiedlichen Seiten der Verpackung (100) zu erstrecken. 45
15. Verpackung (100) nach Anspruch 14, wobei sich das Sicherheitsetikett (1) über eine Vorderseite (102), eine Rückseite (106) und eine Unterseite (104) der Verpackung (100) erstreckt. 50
16. Verpackung (100) nach Anspruch 15, wobei das Si- 55
- cherheitsetikett (1) zwei Zwischenschichten (20) umfasst, wobei eine bereitgestellt ist, um die untere Kante (122) der Kappe (120) auf einer Vorderseite (102) der Verpackung (100) zumindest teilweise zu bedecken, und eine bereitgestellt ist, um die untere Kante (122) der Kappe (120) auf einer Rückseite (106) der Verpackung (100) zumindest teilweise zu bedecken.
17. Verpackung (100) nach Anspruch 15 oder 16, wobei der zweite vorbestimmte Sollbruchstellenbereich (32) auf der Unterseite (104) der Verpackung (100) bereitgestellt ist.
18. Verpackung (100) nach Anspruch 15 oder 16, wobei zwei zweite vorbestimmte Sollbruchstellenbereiche (32) auf unterschiedlichen Seiten der Verpackung (100), die durch das Etikett (1) bedeckt sind, vorzugsweise auf der Vorder- und Rückseite (102, 106) der Verpackung (100), bereitgestellt sind.
19. Verpackung nach einem der vorangehenden Ansprüche, wobei die Grundschrift 10, die Zwischenschicht 20 und die Oberschrift 30 eine Haftschrift auf ihren Rückseiten umfassen.

Revendications

1. Emballage d'article à fumer protégé contre les enfants (100), comprenant :
- un contenant (110) prévu pour contenir des articles à fumer,
- un couvercle (120) destiné à fermer une ouverture du contenant (110) et présentant un bord inférieur (122) contactant le contenant (110) en état de fermeture de l'emballage (100), et séparé du contenant (110) en état d'ouverture de l'emballage (100), et
- une étiquette de sécurité (1) prévue sur l'emballage (100), ladite étiquette de sécurité (1) comprenant :
- une couche inférieure (10) collée à l'emballage (100) et comprenant une première zone (12) à point de rupture prédéfinie de la couche inférieure (10) couvrant au moins une partie du bord inférieur (122) du couvercle (120),
- caractérisé en ce qu'il** comprend en outre une couche intermédiaire (20) au moins partiellement amovible couvrant au moins une partie de la première zone (12) à point de rupture prédéfinie de la couche inférieure (10), et
- une couche supérieure (30) au moins partiellement amovible couvrant la couche in-

- férieure (10) sur laquelle est appliquée la couche intermédiaire (20), et présentant une deuxième zone (32) à point de rupture prédéfinie de ladite couche supérieure (30) au moins partiellement amovible. 5
2. Emballage (100) selon la revendication 1, dans lequel la couche supérieure (30) est au moins partiellement transparente, de préférence entièrement transparente. 10
3. Emballage (100) selon la revendication 1 ou la revendication 2, dans lequel la couche inférieure (10) comprend une première partie (14) fixée par adhésif sur le couvercle (120), une deuxième partie (16) fixée par adhésif sur le contenant (110), la première et la deuxième parties (14, 16) étant assemblées l'une à l'autre de manière amovible par la première zone (12) à point de rupture prédéfinie. 15
4. Emballage (100) selon l'une quelconque des revendications précédentes, dans lequel la couche supérieure (30) comprend une première partie (34) et une deuxième partie (36) assemblées l'une à l'autre de manière amovible par la deuxième zone (32) à point de rupture prédéfinie. 20
5. Emballage (100) selon l'une quelconque des revendications précédentes, dans lequel la première zone (12) à point de rupture prédéfinie comprend au moins une ligne de rupture ou à perforations, de préférence plusieurs lignes de rupture ou à perforations. 25
6. Emballage (100) selon la revendication 4 ou la revendication 5, dans lequel la première zone (12) à point de rupture prédéfinie de la couche inférieure (10) est couverte par la première partie (34) ou par la deuxième partie (36) de la couche supérieure (30) quand la première partie (34) et la deuxième partie (36) de la couche supérieure (30) sont assemblées l'une à l'autre par la deuxième zone (32) à point de rupture prédéfinie. 30
7. Emballage (100) selon l'une quelconque des revendications précédentes, dans lequel la deuxième zone (32) à point de rupture prédéfinie de la couche supérieure (30) est collée à la couche inférieure (10). 35
8. Emballage (100) selon l'une quelconque des revendications précédentes, dans lequel la deuxième zone (32) à point de rupture prédéfinie de la couche supérieure (10) comprend un rabat prévu pour être détaché de la couche inférieure (10). 40
9. Emballage (100) selon l'une quelconque des revendications précédentes, dans lequel la couche supérieure (30) comprend un moyen de réduction de la force d'adhérence (38) de la couche supérieure (30) par rapport à la force d'adhérence du rappel de la couche supérieure (30), devenant accessible après rupture de la deuxième zone (32) à point de rupture prédéfinie. 45
10. Emballage (100) selon l'une quelconque des revendications précédentes, dans lequel la couche intermédiaire (20) est entièrement transparente ou comprend un corps transparent et un élément visuel (22) au moins partiellement non transparent. 50
11. Emballage (100) selon l'une quelconque des revendications précédentes, dans lequel la couche inférieure (10) comprend en outre un élément d'étiquette (18). 55
12. Emballage (100) selon l'une quelconque des revendications précédentes, dans lequel la couche inférieure (10) et la couche supérieure (30) ont la même largeur, ou la même hauteur, ou la même hauteur et la même largeur.
13. Emballage (100) selon l'une quelconque des revendications précédentes, dans lequel au moins deux étiquettes de sécurité (1) sont prévues, chaque étiquette de sécurité (1) étant prévue sur une surface différente de l'emballage.
14. Emballage (100) selon l'une quelconque des revendications précédentes, dans lequel l'étiquette de sécurité (1) est prévue pour s'étendre sur au moins deux surfaces d'emballage (100) différentes.
15. Emballage (100) selon la revendication 14, dans lequel l'étiquette de sécurité (1) s'étend sur une surface avant (102), une surface (106) arrière et une surface de fond (104) de l'emballage (100).
16. Emballage (100) selon la revendication 15, dans lequel l'étiquette de sécurité (1) comprend deux couches intermédiaires (20), une couche étant prévue pour couvrir au moins partiellement le bord inférieur (122) du couvercle (120) sur une surface avant (102) de l'emballage (100), et une couche étant prévue pour couvrir au moins partiellement le bord inférieur (122) du couvercle (120) sur une surface arrière (106) de l'emballage (100).
17. Emballage (100) selon la revendication 15 ou la revendication 16, dans lequel la deuxième zone (32) à point de rupture prédéfinie est prévue sur la surface de fond (104) de l'emballage (100).
18. Emballage (100) selon la revendication 15 ou la revendication 16, dans lequel deux deuxièmes zones (32) à point de rupture prédéfinie sont prévues sur des surfaces différentes de l'emballage (100) couvertes par l'étiquette (1), de préférence sur la surface

avant et la surface arrière (102, 106) de l'emballage (100).

19. Emballage selon l'une quelconque des revendications précédentes, dans lequel la couche inférieure 10, la couche intermédiaire 20 et la couche supérieure 30 comprennent une couche adhésive sur leurs surfaces arrière.

10

15

20

25

30

35

40

45

50

55

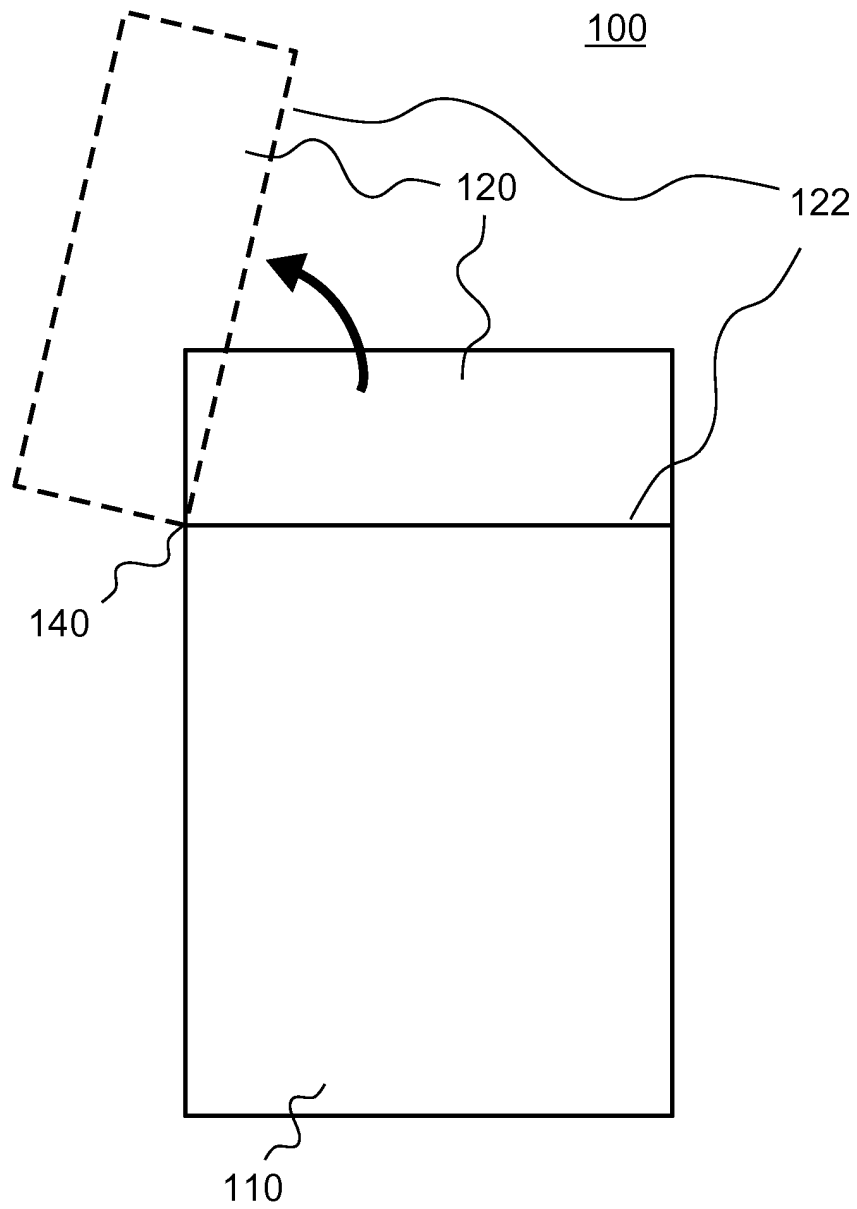

STATE OF THE ART

Fig. 1

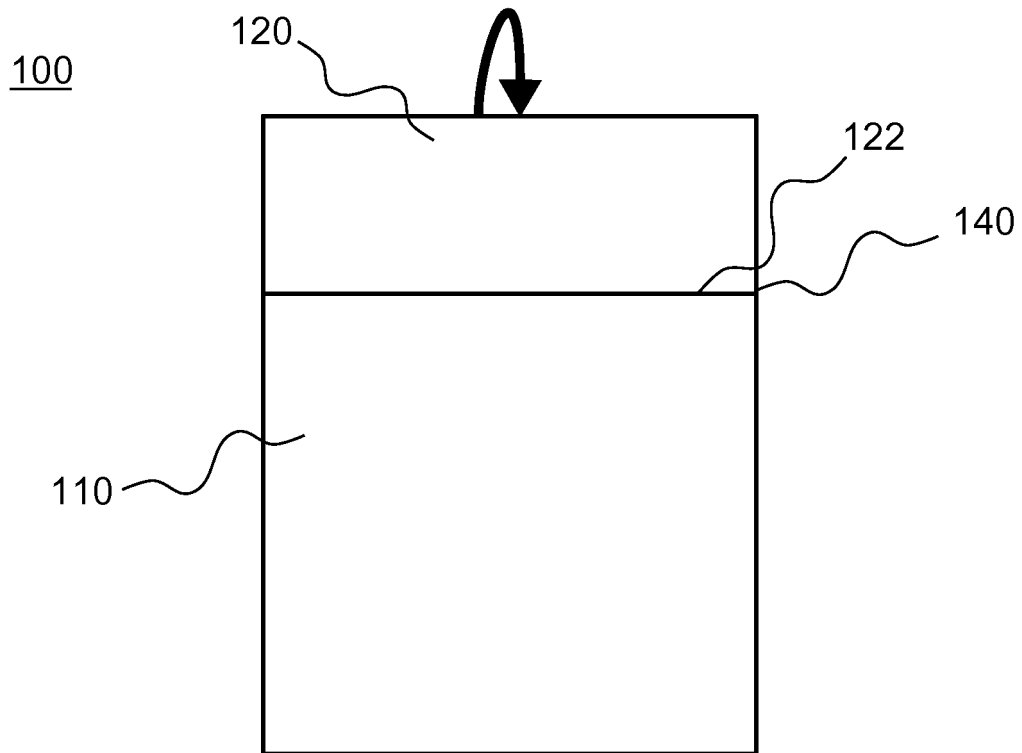

STATE OF THE ART

Fig. 2

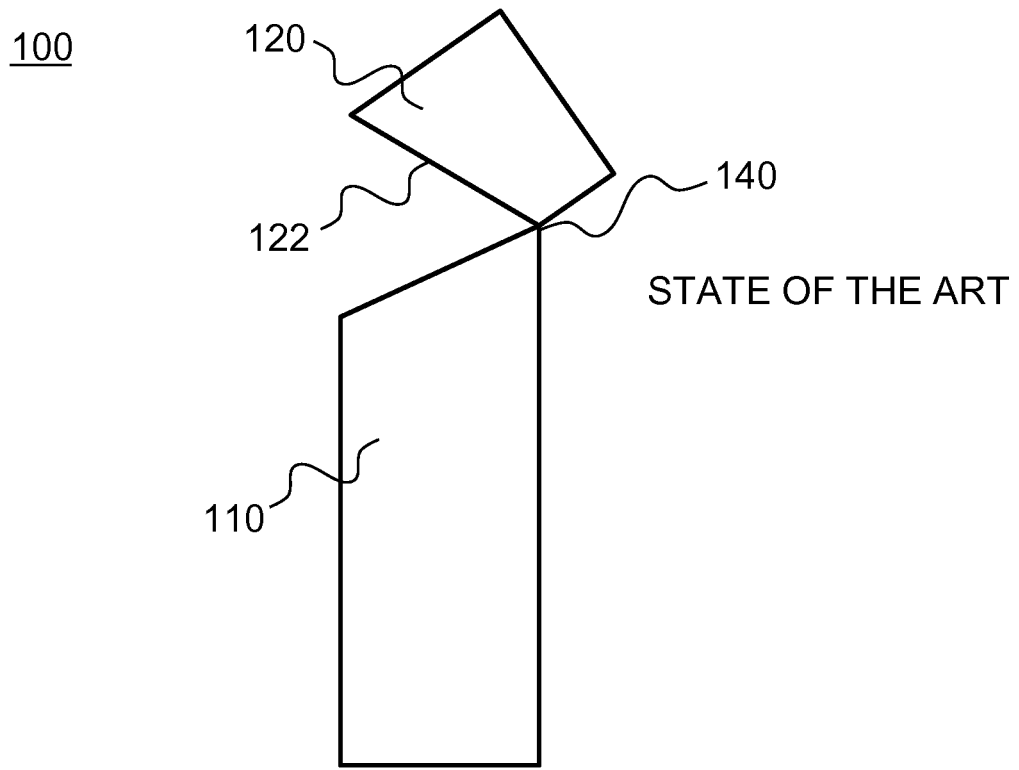

Fig. 3

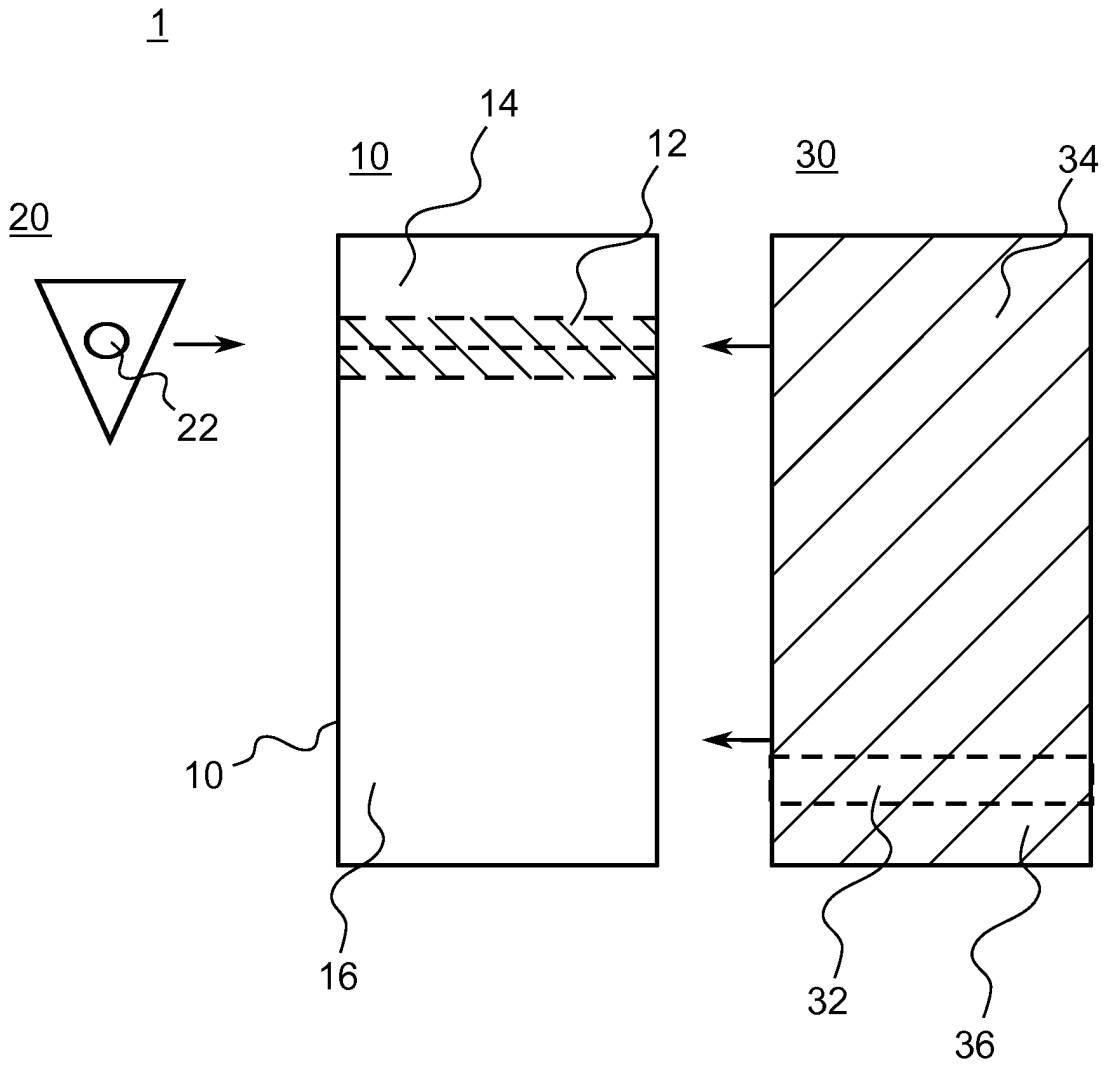

Fig. 4

1

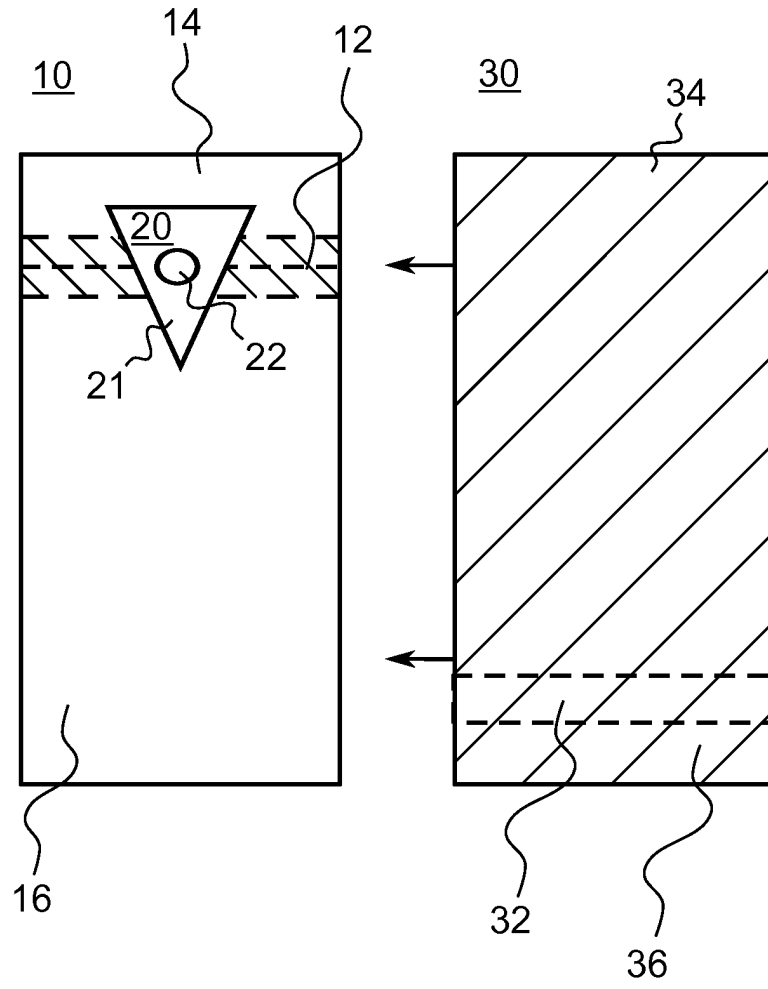

Fig. 5

1

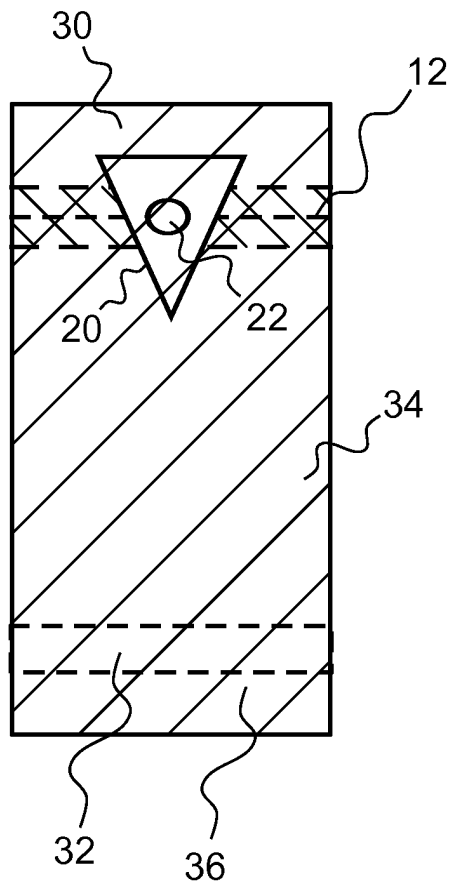

Fig. 6

100

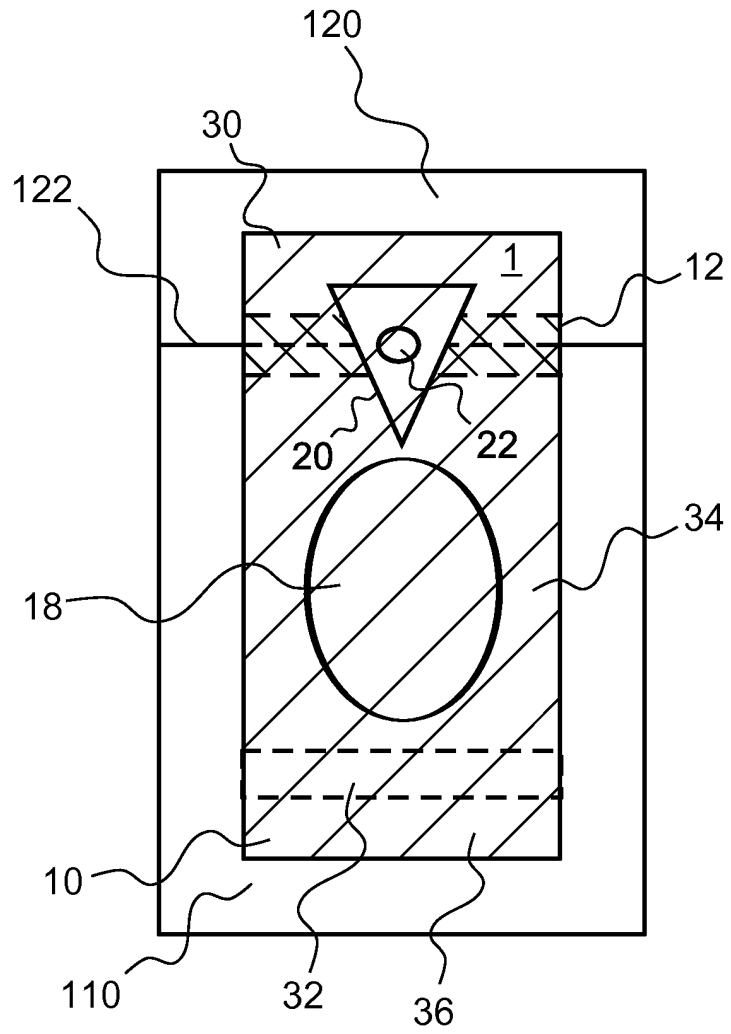

Fig. 7

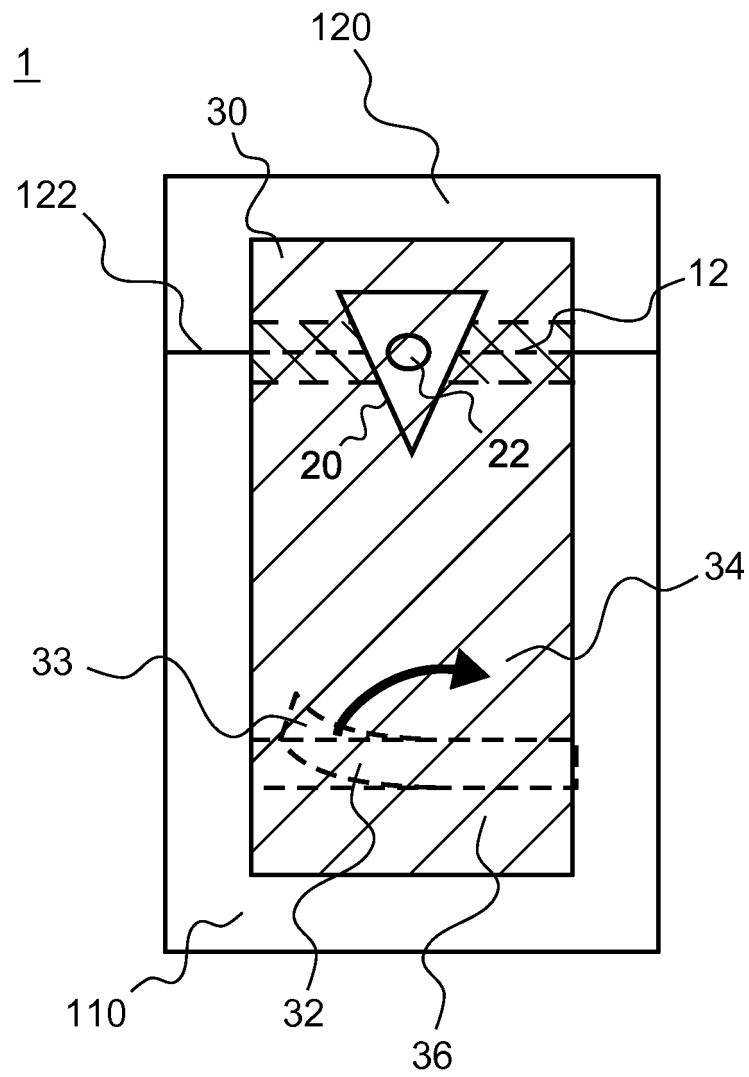

Fig. 8

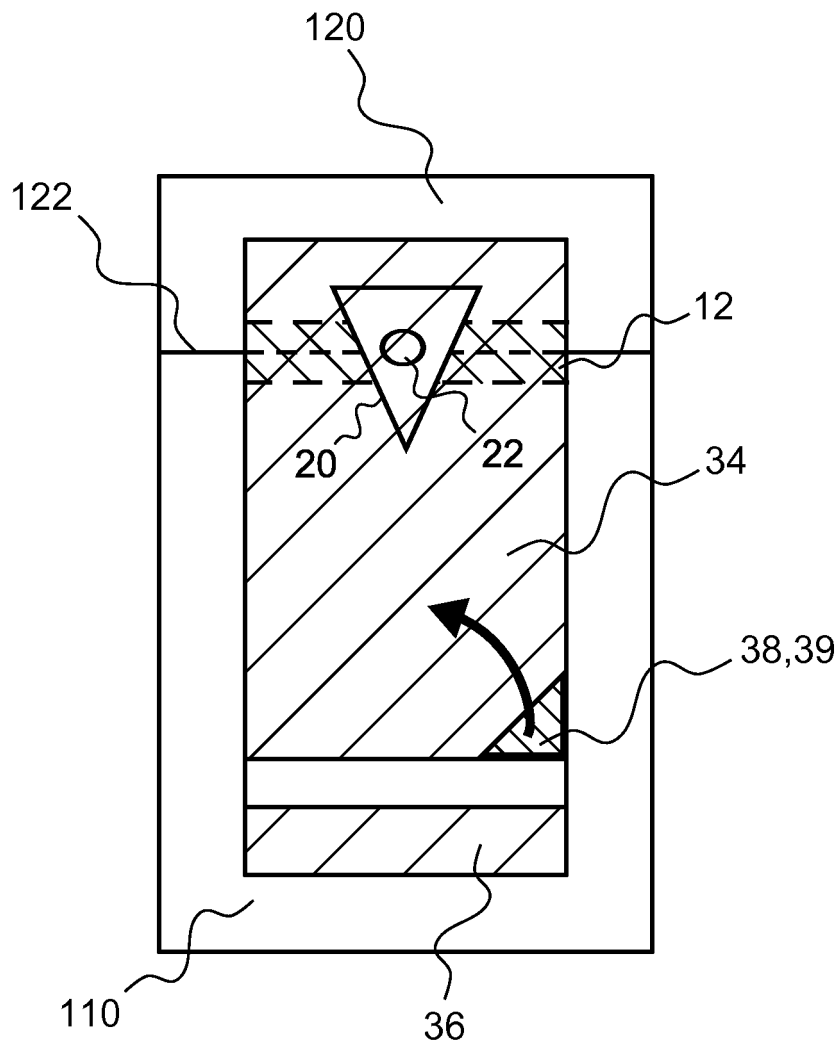

Fig. 9

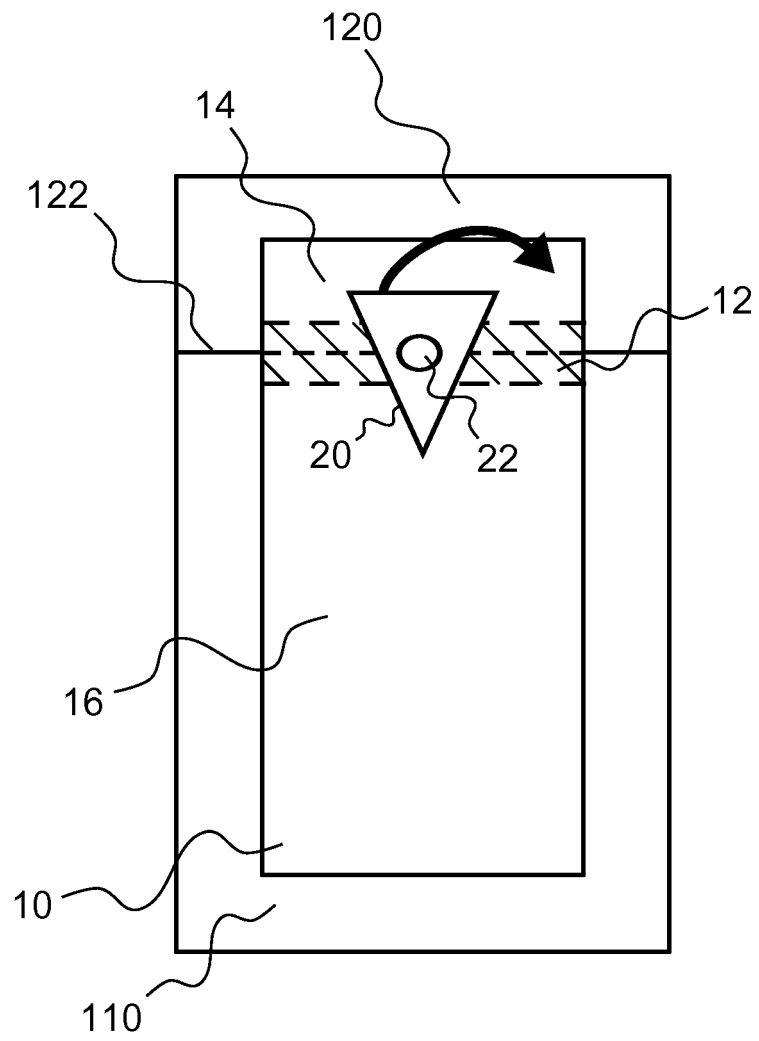

Fig. 10

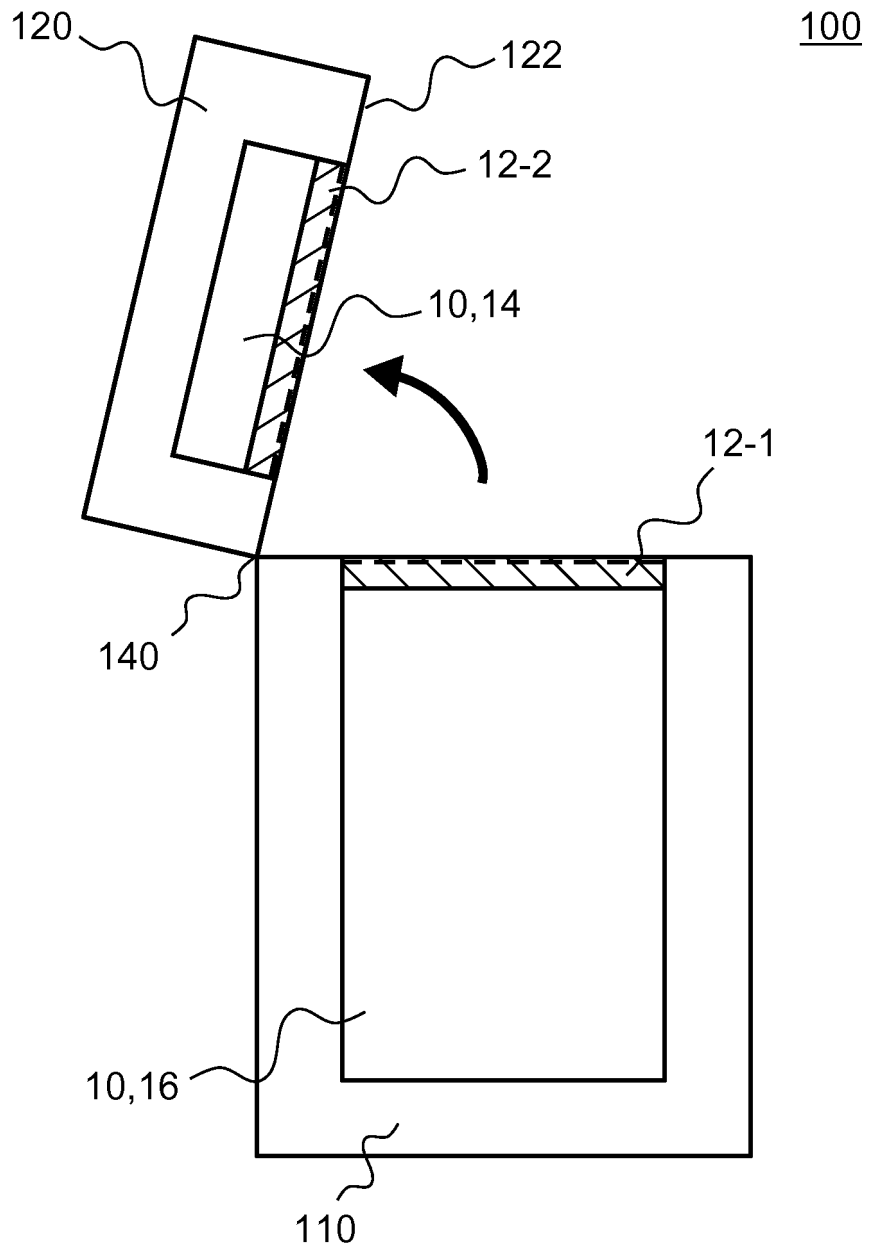

Fig. 11

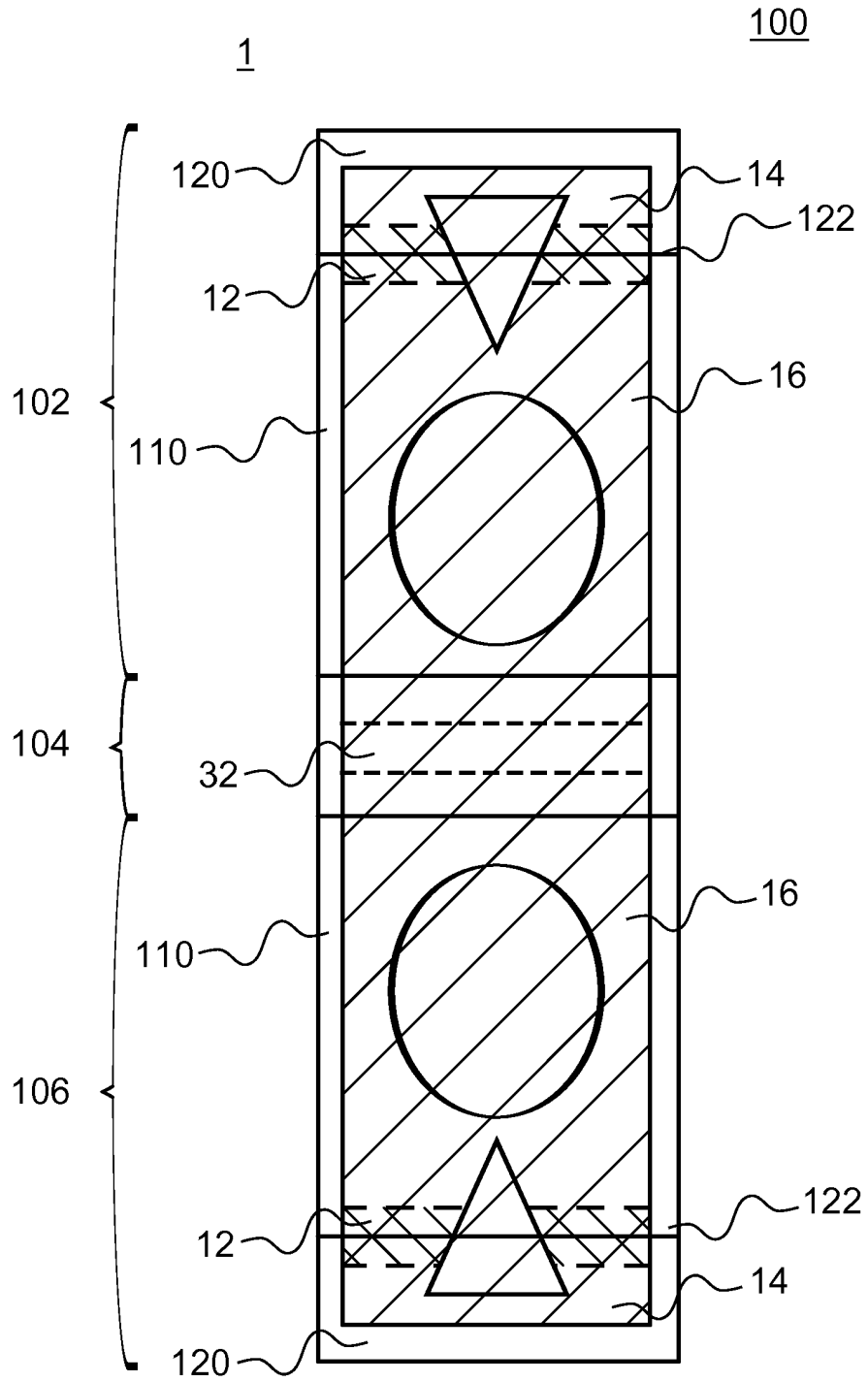

Fig. 12

REFERENCES CITED IN THE DESCRIPTION

This list of references cited by the applicant is for the reader's convenience only. It does not form part of the European patent document. Even though great care has been taken in compiling the references, errors or omissions cannot be excluded and the EPO disclaims all liability in this regard.

Patent documents cited in the description

- GB 2493905 A [0001]