

(No Model.)

W. A. SELZER.
EXTENSIBLE STEP LADDER.

No. 524,512.

Patented Aug. 14, 1894.

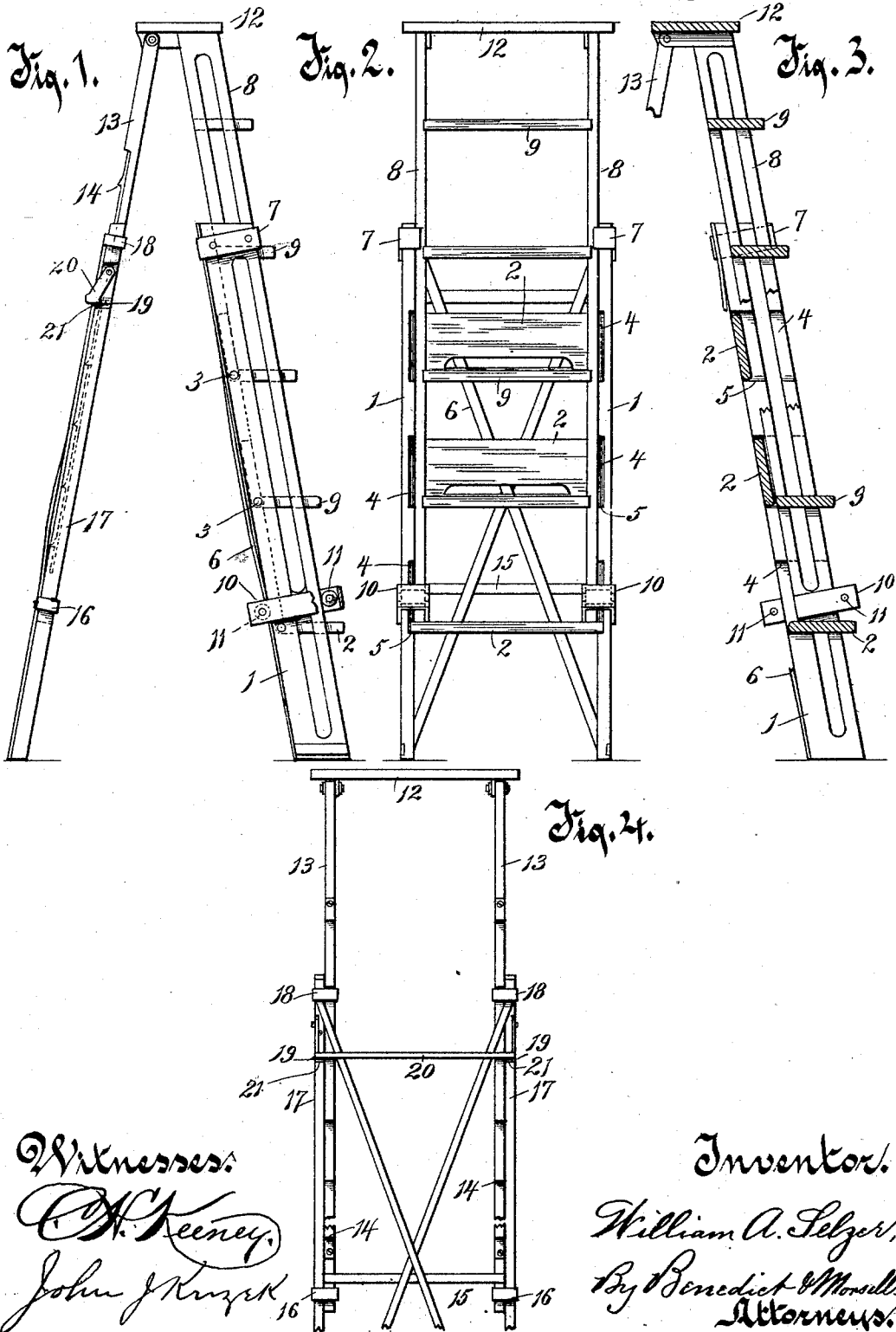

Witnesses:
C. H. Keeney
John J. Krzyk

Inventor:
William A. Selzer
By *Benedict & Morrell*
Attorneys.

UNITED STATES PATENT OFFICE.

WILLIAM A. SELZER, OF MILWAUKEE, WISCONSIN.

EXTENSIBLE STEP-LADDER.

SPECIFICATION forming part of Letters Patent No. 524,512, dated August 14, 1894.

Application filed March 14, 1894. Serial No. 503,585. (No model.)

To all whom it may concern:

Be it known that I, WILLIAM A. SELZER, of Milwaukee, in the county of Milwaukee and State of Wisconsin, have invented a new and useful Improvement in Extensible Step-Ladders, of which the following is a description, reference being had to the accompanying drawings, which are a part of this specification.

My invention has relation to improvements in extensible step ladders.

The object of the device is to provide a construction for expeditiously and conveniently extending and lowering a step ladder, and firmly holding the same in its adjusted position.

With the above primary object in view, the invention consists in the devices and parts, or their equivalents, as hereinafter more fully described and claimed.

In the accompanying drawings, Figure 1, is a side elevation showing the ladder extended, and showing a part broken away. Fig. 2, is a detail front elevation of the ladder, showing the same partly extended. Fig. 3, is a longitudinal vertical sectional view, showing only a fragment of the rear portion of the ladder, and Fig. 4, is a rear elevation, in detail, of the rear portion of the ladder.

Like numerals of reference denote like parts throughout the several views.

Referring to the drawings, the numerals 1, 1, indicate the side pieces of the lower section of the front portion of the ladder, said side pieces being longitudinally slotted to secure lightness in weight. The steps of this section are indicated by the numeral 2, and said steps are provided with laterally-extending pins or trunnions 3, which enter the side pieces, and thereby provide pivotal points for the turning of the steps. The opposite ends of the steps are seated in recesses 4, 4, which recesses form lower shoulders 5, 5, for supporting the steps, when swung down to horizontal positions. The side pieces 1, 1, are braced at their rear edges by means of crossed diagonal strips 6, 6, which strips also serve to limit the backward swing of the pivoted steps.

Secured at the upper ends of the side pieces 1, 1 are angular straps 7, 7, said straps at the

front extending inward laterally beyond the edges of the side pieces.

The upper section of the front portion of the ladder consists of the side pieces 8, 8, also longitudinally slotted for the purpose of securing lightness. Between these side pieces, and secured thereto rigidly, are horizontal steps 9, 9. This upper section is slightly less in width than the lower section, and fits between the side pieces thereof, bearing against the lateral inward-extending portions of the straps 7, 7, the front edges of the side pieces of this lower section being flush with the front edges of the side pieces of the upper section. When the lower hinged steps 2 are swung back to their full extent, as shown by the two upper steps of the lower section in Figs. 2 and 3, the rear edges of the side pieces 8, 8, of the upper section bear against said steps.

To the lower ends of the side pieces of the upper section are secured rectangular straps 10, 10, said straps embracing the sides of the side pieces 1, 1, and projecting beyond the front and rear edges of said side pieces 1, 1, and having mounted in the extended portions anti-friction rollers 11, 11, which bear against the respective edges of said side pieces 1, 1, and thereby materially diminish friction in the extending and lowering of the ladder.

To the upper section of the front portion of the ladder is rigidly secured a top platform 12, and to the under side of this platform, at the rear, is pivoted the upper section of the rear portion of the ladder, consisting of two side pieces 13, 13, which are provided upon their rear edges with ratchet teeth 14, 14. These side pieces are connected and braced by means of a cross strip 15. To their lower ends are secured rectangular straps 16, 16, which embrace the side pieces 17, 17 of the lower section of the rear portion of the ladder. These latter side pieces have secured to their upper ends rectangular straps 18, 18, which embrace the side pieces of the upper section.

Pivoted in recesses 19, 19 in the outer edges of the side pieces 17, 17 are the ends of an angular gravity dog or lock 20. The rear edges of the side pieces 17, 17 at the lower ends of the recesses 19, 19, are notched, as indicated

at 21. When the ladder is raised or lowered, therefore, as soon as any of the teeth 14 come into register with these notches, the dog or lock falls beneath the offsets or shoulders formed by the teeth, and thus supports the ladder in its extended position.

In extending my improved ladder, when the desired height has been reached, the step 2 next below the lower ends of the side pieces 8, 8, of the upper section of the front portion of the ladder, is thrown down upon its pivots to a horizontal position, and the ends of said side pieces 8, 8, allowed to slip down until they rest upon, and are firmly supported by, said step. At the same time, of course, the gravity dog or lock 20 at the rear will automatically engage the teeth, and support the rear portion of the ladder at a corresponding height. Figs. 2 and 3 show the ladder extended so that the lower ends of the side pieces 8, 8, rest on the lower step 2. This lower step 2, therefore, forms the first step of the ladder, and the succeeding steps of the ladder are the steps 9 of the upper side pieces 8, 8, the other steps 2, which are thrown back to their full extent, forming backs for the steps 9.

In lowering the ladder from the position shown in Figs. 2 and 3, the gravity dog or lock 20 is thrown out of engagement with the teeth 14, and the upper portion of the ladder raised a sufficient distance to allow for the swinging back of the lower step 2. When this is done the upper sections of the ladder are, of course, free to lower automatically.

I do not wish to be considered as limiting myself to the specific details of construction herein shown and described, as it is obvious that these may be changed or varied, without departing from the spirit and scope of my invention. For instance, other forms of locking devices may be employed in place of the gravity locking dog 20.

Having thus described my invention, what I claim, and desire to secure by Letters Patent, is—

1. In an extensible ladder, the combination, of a lower front portion, consisting of side pieces provided upon their inner faces, at opposite points, with recesses, steps pivoted at opposite ends within the recesses, said steps adapted, when thrown to a substantially horizontal position, to rest upon the lower edges of the recesses, a stop at the rear of the lower front ladder section adapted to support the steps in a substantially vertical position, when said steps are thrown upward and rearward upon their pivots, an upper front section, comprising side pieces having rigid horizontal steps, said side pieces adapted to fit, and slide, between the side pieces of the lower section, and in front of such of the pivoted steps as are thrown back to approximate vertical positions, the pivoted steps so adjusted acting as backs for the rigid horizontal steps, the pivoted step next below the lower ends of the side pieces of the upper section adapted, when

said upper section is extended, to receive and support the lower ends of the side pieces of the upper section, and a rear section of ladder pivoted to the upper section of the front portion thereof, substantially as set forth.

2. In an extensible ladder, the combination of a lower front portion consisting of side pieces provided upon their inner faces, at opposite points, with recesses, steps pivoted at opposite ends within the recesses, said steps adapted, when thrown to a substantially horizontal position, to rest upon the lower edges of the recesses, strips bracing the side pieces at the rear edges thereof, said strips also acting as supports for the steps, when said steps are thrown upward and rearward upon their pivots, an upper front section comprising side pieces having rigid horizontal steps, said side pieces adapted to fit, and slide, between the side pieces of the lower section, and in front of such of the pivoted steps as are thrown back to approximate vertical positions, the pivoted steps so adjusted acting as backs for the rigid horizontal steps, the pivoted step next below the lower ends of the side pieces of the upper section adapted, when said upper section is extended, to receive and support the lower ends of the side pieces of the upper section, and an upper rear section of ladder, pivoted to the upper section of the front portion thereof, substantially as set forth.

3. In an extensible ladder, the combination, of upper and lower front sections, the side pieces of the upper section adapted to fit, and slide, between the side pieces of the lower section, the front edges of the side pieces of both sections being flush, rectangular straps for the side pieces of the respective sections, the sides of said straps bearing against the sides of the respective side pieces of the ladder sections, and the ends of said straps extended beyond the front and rear edges of the side pieces of the sections, transverse shafts mounted in said extended ends of the straps, anti-friction rollers mounted upon the shafts, the front rollers bearing against the flush front edges of the side pieces of the respective ladder sections, and the rear roller bearing against the rear edges of the side pieces of the lower ladder sections, and a rear section of ladder pivoted to the upper section of the front portion thereof, substantially as set forth.

4. In an extensible ladder, the combination, of front telescoping sections, means for holding said sections in adjusted position, a rear upper section pivoted to the upper front section, the side pieces of said rear upper section having a series of notches on their rear edges, a lower rear section within which the upper section is adapted to slide, the outer sides of the side pieces of said lower section provided with recesses, said recesses having notches at their lower ends, and a gravity dog or lock, consisting of a transverse portion

and end pieces, said end pieces fitting in the recesses of the side pieces of the lower section, and the transverse portion of this dog or lock adapted to engage the teeth of the upper section, when said teeth are brought into register with the notches of the recesses, substantially as set forth.

In testimony whereof I affix my signature in presence of two witnesses.

WILLIAM A. SELZER.

Witnesses:

ARTHUR L. MORSELL,
C. H. KEENEY.