

May 31, 1966

H. J. M. VAN TOL

3,254,260

ELECTRON DISCHARGE DEVICE FOR VERY HIGH FREQUENCIES

Filed Dec. 16, 1963

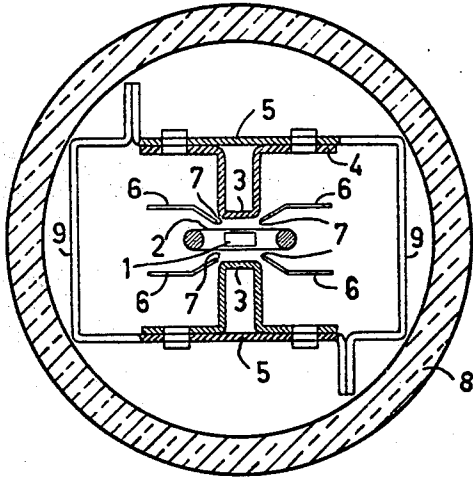

FIG. 1

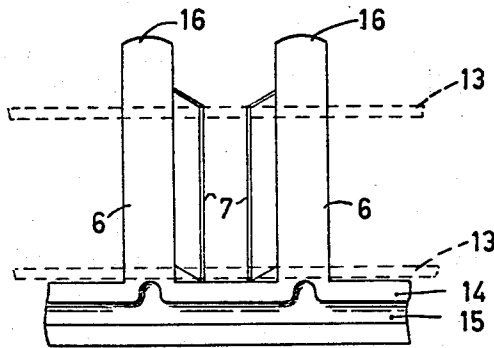

FIG. 2

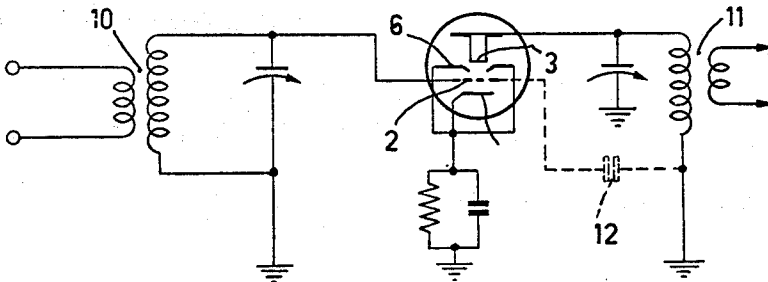

FIG. 3

INVENTOR.

HENDRIKUS J.M. VAN TOL

BY

Frank R. Juffei

AGENT

1

2

3,254,260

ELECTRON DISCHARGE DEVICE FOR VERY HIGH FREQUENCIES

Hendrikus Johannes Marie Van Tol, Emmasingel, Eindhoven, Netherlands, assignor to North American Philips Company, Inc., New York, N.Y., a corporation of Delaware

Filed Dec. 16, 1963, Ser. No. 330,831

Claims priority, application Netherlands, Dec. 27, 1962, 287,234

10 Claims. (Cl. 313—293)

My invention relates to an electric discharge device for amplifying high-frequency electrical oscillations and, more particularly, to an electron discharge tube having a very low noise level.

For amplifying high-frequency signals, particularly in the first stage of a receiver, the tube should produce very little noise. In general, pentodes or tetrodes are employed, but because there is a screen-grid current, they produce distribution noise due to the distribution of electrons between the screen grid and the anode. In this respect, a triode is preferred, but it has the disadvantage that there is coupling between the anode and the grid due to the anode to grid capacity, so that neutralisation is required. However, this is difficult to achieve, particularly when tubes must be changed. This disadvantage can be avoided by using two triodes in cascade arrangement, but this solution is, however, expensive.

In British Patent 909,917 a tube is described which has the favorable effect of a triode.

In this tube, the electrode system comprises a cathode, a grid, an anode and an auxiliary electrode, the anode comprising two halves, each having a depression oriented towards the cathode and having approximately the same width as the cathode. These depressions constitute the active anode surface, while on either side between the anode parts and the grid there are arranged U-shaped screens, the free edges of which are located near the active anode parts, approximately in the plane thereof, so that the anode-to-grid capacity is determined solely by the active parts of the grid and the anode. Since the distance between the active parts of the anode and the grid is small, difficulties may arise in connection with the tolerances of the U-shaped screens. As a consequence, the edges of the screens cannot always be arranged so that the grid-to-anode capacity is at a minimum.

It is an object of the invention to improve the construction of this tube so that the anode-to-grid capacity is considerably reduced.

This and further objects of the invention will appear as the specification progresses.

In accordance with the invention, the U-shaped screens are replaced by four strips, while the places of the active edges thereof are determined by apertures in insulating centering members so that these edges are located between the edge of the active anode part and the active grid surface. Such apertures may have a very small tolerance, and since the screens are formed by separate strips, their positions are independent of each other and solely determined by the apertures in the insulating members.

Since it is now possible to arrange the active edges of the screens between the active parts of the grid and the anode, the anode-to-grid capacity is approximately reduced by half as compared with that of the tube described in said British patent.

The strips must be electrically connected to each other. Thus, the strips located on the same side of the cathode are interconnected beneath a mica centering member so that they are integral with this interconnection, which unit can, subsequent to the mounting of the electrode system, be slipped into gaps in the mica member. The

strips may be integral with a strip-shaped connecting member. Since the active edges are located on bent-over parts of the strips, the small tolerance can be obtained by bending. The wide connecting strip may simultaneously serve as a screening member for the current supply conductors.

The invention will be described more fully with reference to the accompanying drawing in which:

FIG. 1 is a cross-sectional view of a tube according to the invention,

FIG. 2 is an elevational view of the screens; and

FIG. 3 is a circuit diagram of an amplifier employing a tube according to the invention.

Referring to FIG. 1, a cathode 1, extending longitudinally of the tube, is surrounded by a grid 2 which is formed by a wire wound tightly on a frame, i.e., a frame grid. Active anode parts 3 are formed by depressions of anode plates 4, which depressions form a box with the plates 5 and operate at the same time as cooling vanes. In accordance with the invention, strip-shaped screens 6 are arranged between the anode plates 4 and grid 2, the active edges 7 of which are located between the edges of the active parts 3 of the anode and the active parts of the grid 2. It has been found that the capacity of the active parts of the grid 2 and the anode parts 3 is approximately half of the value in the case in which the active edges 7 of the screens 6 are co-planar to the anode parts 3. Thus, the conventional neotrodyne capacitor 12 can be completely omitted from the arrangement shown in FIG. 3. The electrode system is housed in a glass envelope 8. The width of the anode parts 3 is approximately equal to the width of the cathode 1, so that a narrow electron beam can be used.

Since the place of the edges 7 of the screens 6, arranged practically independently of each other, is determined solely by the end of a gap in mica centering members (not shown) located near the anode parts 3, between which the electrodes are mounted in a conventional manner, the place of the edges 7 only has the extremely small tolerance at one end of said gap-shaped apertures of the mica members. Since the screens 6 are formed by slightly kinked strips, the deviations, due to tolerances in respect of the width of said strips and the length of the apertures in the mica members, may occur on the side of the strips and the apertures remote from the edges 7, where there is no risk of short-circuiting with the further electrodes. The distances of the edges 7 from the edge of the anode may, for example, be 120 μ and from the grid wires, 385 μ , where the risk of short-circuit is much greater. The width of the active anode part may be 1.2 mm. while the diameter of the grid stay wires may be 0.7 mm., and the diameter of the grid wire may be 8 μ . The emissive cathode surface is 1.4 x 5.8 mm. The cathode tube has a cross-section of 0.6 x 1.4 mm. and an overall length of 9.4 mm. The cathode has an emissive layer which is 25 μ in thickness.

The two anode halves are connected together by wires or narrow strips 9, which, however, have no appreciable influence on the anode-to-grid capacitance.

From FIG. 2, it appears that two strips 6, located on the same emissive side of the cathode, may be integral with a strip-shaped connecting conductor 14. The connecting strip 14 may, at the same time, serve as a screen between the current supply conductors of the grid and the anode. Since the edges 7 are located on kinked parts of the strips 6, the positions thereof can be completely determined by the edges of the gaps of the mica members, since the kinked parts are sufficiently elastic to permit a slight deformation when the electrodes are slipped into the apertures of the mica members. The connecting strip 14 may be provided with a stiffening ridge 15.

In the arrangement shown in FIG. 3, input circuit 10 is connected to the grid 2 and amplified signals are derived from output circuit 11. The screens 6 are connected in this case to the cathode 1. With the embodiment of the screens 6, in accordance with the invention, it has been found that the neutrodyne capacitance 12, shown in broken lines, can be completely omitted.

Although a single embodiment is shown and described above, it will be apparent that, for example, the non-active anode parts may be formed in any other way in order to obtain a satisfactory cooling of the anode. Also, the dimensions and the disposition of the screens 6 may be slightly varied, provided the edge 7 is held at the correct place.

Therefore, while the invention has been described with reference to a particular embodiment thereof, other modifications will be apparent to those skilled in the art without departing from the spirit and scope of the invention which is defined in the appended claims.

What I claim is:

1. An electron discharge device for high frequencies comprising a tube including a cathode of given width, a grid electrode composed of a wire grid substantially surrounding said cathode, an anode structure comprising a section extending substantially parallel to said grid electrode on one side thereof, said anode structure having at least one planar active portion extending integrally therefrom to a position closer to said wire grid than residual inactive positions thereof, said active anode portion having a width substantially equal to the given cathode width, and shield members interposed between said wire grid and the inactive anode portions, each shield member comprising a kinked strip-shaped member having an active portion extending into proximity with said active anode portion and having an edge region between a corresponding edge of said active anode portion and said wire grid whereby capacitance between said grid electrode and said anode structure is substantially less than a comparable tube having shields substantially coplanar with the active anode portion.

2. An electron discharge device comprising a tube including a cathode of given width, a grid electrode composed of a wire grid substantially surrounding said cathode, an anode structure comprising a section extending substantially parallel to said grid electrode on one side thereof, said anode structure having at least one planar active portion extending integrally therefrom to a position closer to said wire grid than residual inactive positions thereof, said active anode portion having a width substantially equal to the given cathode width, and shield members interposed between said wire grid and the inactive anode portions, each shield member comprising a kinked strip-shaped member having an active portion extending into proximity with said active anode portion and having an edge region between a corresponding edge of said active anode portion and said wire grid, each of said edge regions being positioned closer to the corresponding edge of said anode than to said wire grid whereby capacitance between said grid electrode and said anode structure is substantially less than a comparable tube having shields substantially coplanar with the active anode portion.

3. An electron discharge device comprising a tube including a cathode of given width, a grid electrode composed of a wire grid substantially surrounding said cathode, an anode structure comprising a section extending substantially parallel to said grid electrode on one side thereof, said anode structure having at least one planar active portion extending integrally therefrom to a position closer to said wire grid than residual inactive positions thereof, said active anode portion having a width substantially equal to the given cathode width, and shield members interposed between said wire grid and the inactive anode portions, each shield member comprising a kinked strip-shaped member having an active portion ex-

tending into proximity with said active anode portion and having an edge region between a corresponding edge of said active anode portion and said wire grid, each of said edge regions being located a distance from the corresponding anode edge which is about one third the distance from the grid whereby capacitance between said grid electrode and said anode structure is substantially less than a comparable tube having shields substantially coplanar with the active anode portion.

4. An electron discharge device comprising a tube including a cathode of given width, a grid electrode composed of a wire grid substantially surrounding said cathode, an anode structure comprising two sections extending substantially parallel to each other and to said grid electrode on both sides thereof, said anode structure having planar active portions extending integrally therefrom to a position closer to said wire grid than residual inactive positions thereof, said active anode portions having a width substantially equal to the given cathode width, and four shield members interposed between said wire grid and the inactive anode portions, each shield member comprising a kinked strip-head member having an active portion extending into proximity with one of said active anode portions and having an edge region between a corresponding edge of said active anode portion and said wire grid whereby capacitance between said grid electrode and said anode structure is substantially less than a comparable tube having shields substantially coplanar with the active anode portion.

5. An electron discharge device comprising a tube including a cathode of given width, a grid electrode composed of a wire grid substantially surrounding said cathode, an anode structure comprising two sections extending substantially parallel to each other and to said grid electrode on both sides thereof, said anode structure having planar active portions extending integrally therefrom opposite said cathode to a position closer to said wire grid than residual inactive positions thereof, said active anode portions having a width substantially equal to the given cathode width, and four shield members interposed between said wire grid and the inactive anode portions, each shield member comprising a kinked strip-shaped member having an active portion extending into proximity with one of said active anode portions and having an edge region between a corresponding edge of said active anode portion and said wire grid, each of said edge regions being positioned closer to the corresponding edge of said anode than to said wire grid whereby capacitance between said grid electrode and said anode structure is substantially less than a comparable tube having shields substantially coplanar with the active anode portion.

6. An electron discharge device comprising a tube including a cathode of given width, a grid electrode composed of a wire grid substantially surrounding said cathode, an anode structure comprising two sections extending substantially parallel to each other and to said grid electrode on both sides thereof, said anode structure having at least one planar active portion extending integrally therefrom to a position closer to said wire grid than residual inactive positions thereof, said active anode portions having a width substantially equal to the given cathode width, and four shield members interposed between said wire grid and the inactive anode portions, each shield member comprising a kinked strip-shaped member having an active portion extending into proximity with one of said active portions and having an edge region between a corresponding edge of said active anode portion and said wire grid, each of said edge regions being located a distance from the corresponding anode edge which is about one third the distance from the grid whereby capacitance between said grid electrode and said anode structure is substantially less than a comparable tube having shields substantially coplanar with the active anode portion.

7. An electron discharge device comprising a tube including a cathode of given width, a grid electrode com-

5

posed of a wire grid substantially surrounding said cathode, an anode structure comprising a section extending substantially parallel to said grid electrode on one side thereof, said anode structure having at least one planar active portion extending integrally therefrom to a position closer to said wire grid than residual inactive positions thereof, said active anode portion having a width substantially equal to the given cathode width, said cathode, grid and anode constituting an array, and at least one pair of shield members interposed between said wire grid and the inactive anode portion, each shield member comprising a kinked strip-shield member having an active portion extending into proximity with said active anode portion and having an edge region between a corresponding edge of said active anode portion and said wire grid whereby capacitance between said grid electrode and said anode structure is substantially less than a comparable tube having shields substantially coplanar with the active anode portion, and a conductive member connecting said shield members together on one side of said array.

8. An electron discharge device comprising a tube including a cathode of given width, a grid electrode composed of a wire grid substantially surrounding said cathode, an anode structure comprising two sections extending substantially parallel to each other and said grid electrode on both sides thereof, said anode structure having at least one planar active portion extending integrally therefrom to a position closer to said wire grid than residual inactive positions thereof, said active anode portion having a width substantially equal to the given cathode width, said cathode, grid and anode constituting an array, four shield members interposed between said wire grid and the inactive anode portions, each shield member comprising a kinked strip-shield member having an active portion extending into proximity with one of said active anode portions and having an edge region between a corresponding edge of said active anode portion and said wire grid, each of said edge regions being positioned closer to said anode edge than to said grid whereby capacitance between said grid electrode and said anode structure is substantially less than a comparable tube having shields substantially coplanar with the active anode portion, and a conductive strip-shaped member connecting one pair of said shield members between one active anode portion and the grid on one side of the array, said conductive member screening the array.

9. An electron discharge device comprising a tube including a cathode of given width, a grid electrode composed of a wire grid substantially surrounding said cathode, an anode structure comprising two sections extending substantially parallel to each other and to said grid electrode on one side thereof, said anode structure having planar active portions extending integrally therefrom on opposite sides of said cathode to a position closer to said wire grid than residual inactive positions thereof, said

6

active anode portions having a width substantially equal to the given cathode width, a tubular member for supporting said anode and surrounding said grid and cathode and forming therewith a tubular array, pairs of shield members interposed between said wire grid and the inactive anode portions on opposite sides of the cathode, each shield member comprising a kinked strip-shield member having an active portion extending into proximity with one of said active anode portions and having an edge region between a corresponding edge of said active anode portion and said wire grid whereby capacitance between said grid electrode and said anode structure is substantially less than a comparable tube having shields substantially coplanar with the active anode portion, and a conductive strip-like member connecting each pair of shield members positioned on one side of said array and shielding said array.

10. An electron discharge device for high frequencies comprising a tube including a cathode of given width, a grid electrode composed of a wire grid substantially surrounding said cathode, an anode structure comprising a section extending substantially parallel to said grid electrode on one side thereof, said anode structure having at least one planar active portion extending integrally therefrom to a position closer to said wire grid than residual inactive positions thereof, said active anode portion having a width substantially equal to the given cathode width, shield members interposed between said wire grid and the inactive anode portions, each shield member comprising a kinked strip-shaped member having an active portion extending into proximity with said active anode portion and having an edge region between a corresponding edge of said active anode portion and said wire grid whereby capacitance between said grid electrode and said anode structure is substantially less than a comparable tube having shields substantially coplanar with the active anode portion, means to apply a high-frequency signal to said grid, means to derive a signal from said anode without neutralizing anode-to-grid capacitance, and means coupling said shield members to said cathode.

References Cited by the Examiner

UNITED STATES PATENTS

2,460,382	2/1949	Fulton	313—298	X
2,599,629	6/1952	Grimm et al.	313—299	X
2,837,673	6/1958	Quigley et al.	313—298	X
2,913,617	11/1959	Tucker	313—296	
2,968,742	1/1961	Eland	313—299	X

FOREIGN PATENTS

631,240 6/1936 Germany.

JOHN W. HUCKERT, *Primary Examiner.*

DAVID J. GALVIN, *Examiner.*

A. J. JAMES, *Assistant Examiner.*