

W. S. WESTON.
ELECTRIC LAMP HANGER.

No. 526,825.

Patented Oct. 2, 1894.

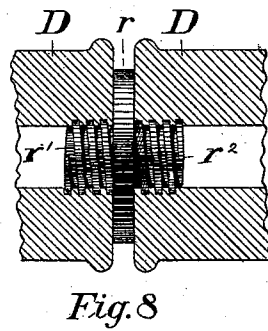
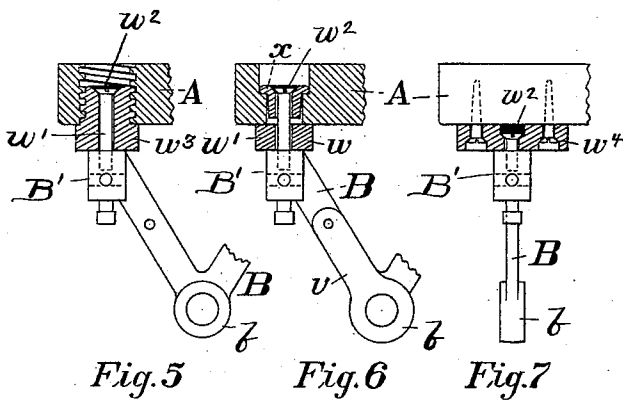
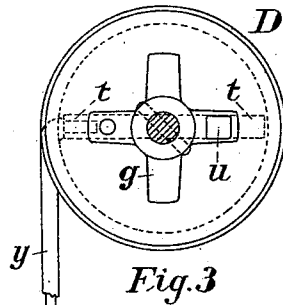
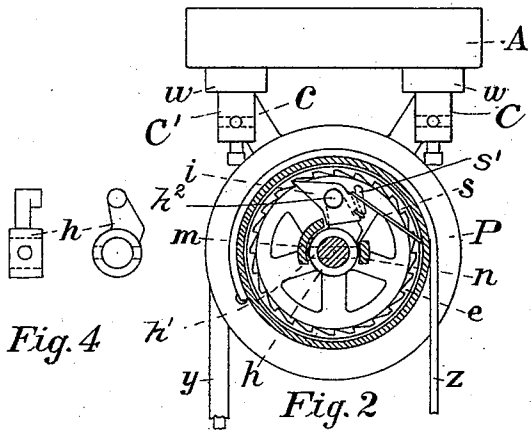
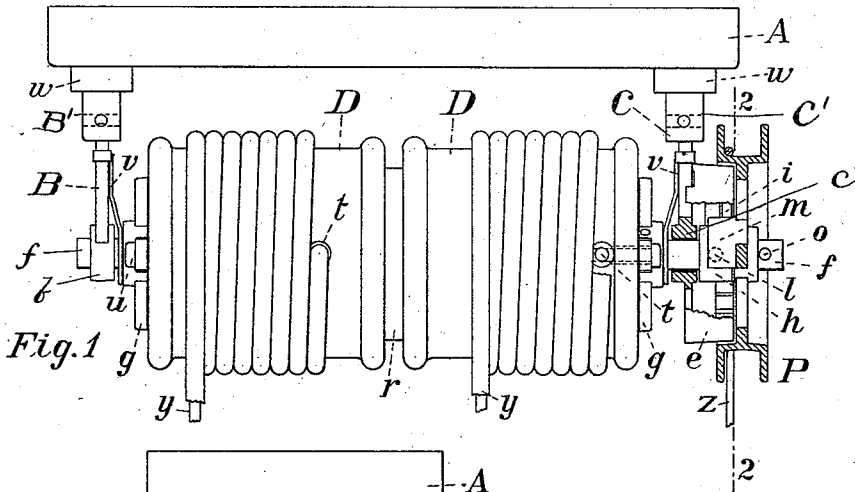

Witnesses
Sew. C. Curtis
A. M. Munday

Inventor
 WILLIAM S. WESTON.
 BY *Munday, Curtis & Adcock,*
 HIS ATTORNEYS

W. S. WESTON.
ELECTRIC LAMP HANGER.

No. 526,825.

Patented Oct. 2, 1894.

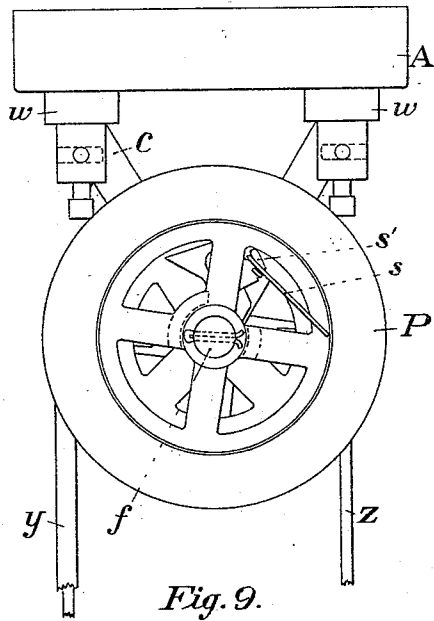

Fig. 9.

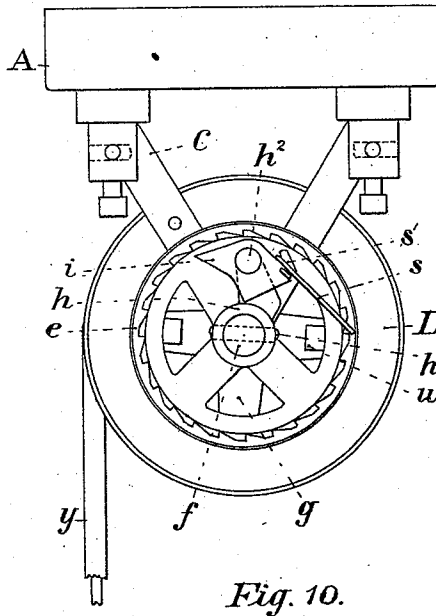

Fig. 10.

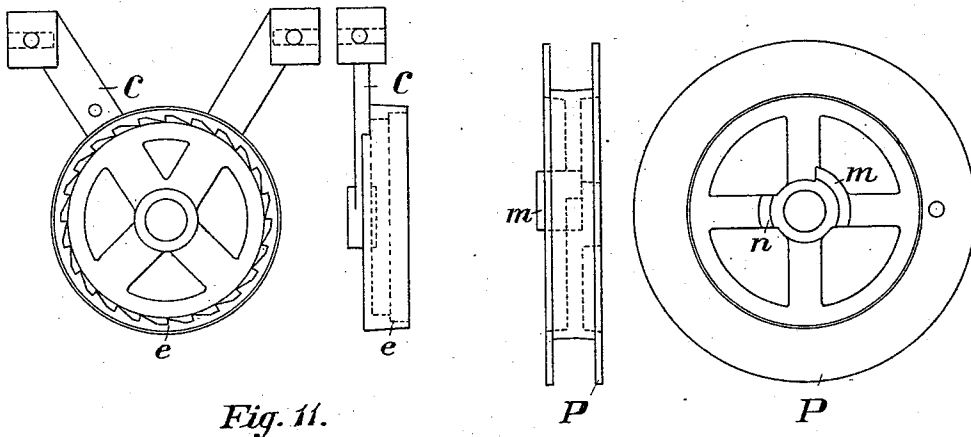
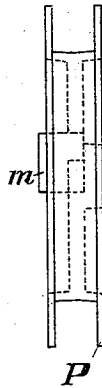
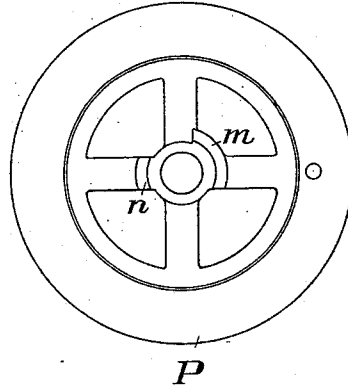

Fig. 11.



P



P

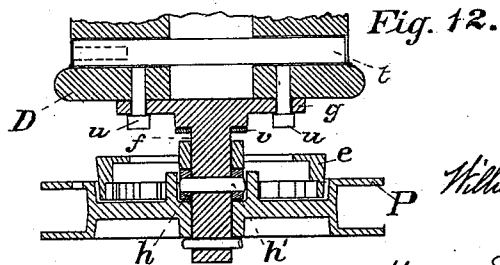

Fig. 13.

Witnesses:
H. M. ...
S. C. ...

William S. Weston
 Inventor

By Munday, Evans & Adcock,
 his attorneys

UNITED STATES PATENT OFFICE.

WILLIAM S. WESTON, OF CHICAGO, ILLINOIS.

ELECTRIC-LAMP HANGER.

SPECIFICATION forming part of Letters Patent No. 526,825, dated October 2, 1894.

Application filed January 13, 1894. Serial No. 496,728. (No model.)

To all whom it may concern:

Be it known that I, WILLIAM S. WESTON, a citizen of the United States, residing in Chicago, in the county of Cook and State of Illinois, have invented a new and useful Improvement in Electric-Lamp Hangers, of which the following is a specification.

My invention relates to improvements in that class of electric lamp hangers in which the conductor cables for the lamp are wound upon a revolving drum, and in which a hand rope or cable wound upon the same or another drum or pulley fixed or loose on the same axis is operated to raise or lower the lamp for renewal or repairs.

The object of my invention is to produce an electric lamp hanger of a simple, efficient and durable construction, whereby the lamp may be retained suspended in any desired position, which will operate automatically to arrest the descent of the lamp in case of accident, such for example as the breaking of the hand rope or the accidental letting go of the same by the operator, and which may be easily and conveniently operated, and wherein also the lamp and electric connections are properly insulated from the hanger board and ceiling or supports to which the hanger is attached, and wherein also the two electric terminals on or in the body of the drum are properly insulated from each other.

My invention consists in the means I employ to accomplish these results; that is to say it consists primarily in connection with a hanger board or frame of a revolving lamp supporting drum and a hand rope for operating or revolving the same, of a ratchet mounted on the frame and a revolving pawl normally held in engagement with the ratchet by a spring or equivalent device, the revolving pawl being connected directly or indirectly with the hand rope, so that the pawl may be released or operated or held out of engagement with the ratchet by the hand rope. The fixed ratchet and revolving pawl thus normally support the weight of the lamp. When the hand rope is pulled so as to release the pawl from the ratchet the weight of the lamp is thrown upon the hand rope, but if the hand rope should break or the operator should let loose of it, the pawl would be instantly thrown

by its spring into engagement with the ratchet and the descent of the lamp thus prevented.

In practicing my invention I preferably provide a separate and distinct pulley or drum for the hand rope from that upon which the conductor cables are wound in order that the hand rope may be outside of the bracket upon which the drum shaft is journaled; and the connection between the hand rope and the revolving pawl is preferably made through the pulley upon which the hand rope is wound. The revolving pawl may be mounted or carried upon any revolving part of the mechanism fixed to or connected with the drum or its shaft. I preferably however mount the revolving pawl upon an arm separate and distinct both from the conductor cable drum and the hand rope pulley or drum, this separate arm or spider being of course secured to the main shaft upon which the drum is mounted.

My invention further consists in the novel devices and novel combinations of parts and devices herein shown and described and more particularly pointed out in the claims.

In the accompanying drawings which form a part of this specification, and in which similar letters of reference indicate like parts throughout all the figures, Figure 1 is a front view, partly in section, of an electric lamp hanger embodying my invention. Fig. 2 is a section taken on line 2—2 of Fig. 1 showing the parts inside the internal ratchet. Fig. 3 is an end view of the conductor cable drum showing the spider or end plate attached to each end of the drum, and showing the method of connecting the conductor cables electrically. Fig. 4 gives two different views of the collar and arm upon which the revolving pawl is pivoted and by which it is revolved or carried around with the drum or its shaft. Fig. 6 is a detail sectional view showing the construction of the hanger bracket and its connection with the hanger board. Figs. 5 and 7 show modifications of the electrically insulated connection between the metallic bracket of the hanger upon which the drum shaft is journaled and the hanger board. Fig. 8 is a partial central longitudinal section of the drum upon which the conductor cables are wound, and showing the means for insulating the two parts thereof from each other. Figs.

9 and 10 are right hand end views showing the pawl held out of engagement with the ratchet. Fig. 11 shows a side edge view of the bracket carrying the ratchet, and Fig. 12 is an edge and inside face view of the hand rope pulley. Fig. 13 is a section.

In the drawings A represents the hanger board. B C are two brackets secured to the hanger board by insulated connections hereinafter to be described and furnished with journals *b c* for the shaft *f* of the drum or drums upon which the conductor cables *y y* and the hand rope Z are wound. The lamp supporting drum D D is made in two similar sections or parts insulated from each other by separator *r* of glazed porcelain or other analogous material, the same being preferably furnished with screw threaded extensions *r' r''* entering the two sections of the drum D D and thus serving also to secure the two parts of the drum together as well as to insulate them from each other. A separate drum or pulley P mounted on the shaft *f* is preferably employed for the hand rope Z.

Secured to the bracket C is a fixed or non-revolving ratchet *e* concentric with the shaft *f*; this ratchet being preferably an internal ratchet, and also preferably made a part of or integral with the bracket C. The revolving pawl *i* is pivoted to and revolved or carried around by a sleeved arm *h* secured to the shaft *f* in position such that the pivoted pawl may engage the teeth of the ratchet *e*. The revolving pawl *i* is normally held in engagement with the teeth by a spring *s*, one end of which is secured to a lug *s'* on the pawl *i*, and the other end of which fits against the inner surface of the pulley P. The pawl carrying arm *h* is secured to the shaft *f* by a pin *h'* extending through a hole in the shaft *f*. The pin *h'* is prevented from coming out by flanges or projections *m n* on the pulley P or its hub. The flange or projection *m* also serves in connection with the pulley P, which is loose on the shaft *f*, as a convenient means of connecting the hand rope Z with the pawl *i*, so that the pawl may be operated or disengaged from the ratchet *e* by pulling on the hand rope Z. The lug *n* on the pulley P also serves to limit the vibratory or rotary motion of the pulley in respect to the shaft *f* and the revolving pawl carrying arm *h* secured thereto. The shaft *f* is rigidly connected to the metallic spiders *g g*, which in turn are rigidly connected to the drum D D.

The pawl *i* is prevented from coming off the short pivot pin *h''* of the arm *h* by one of the spokes of the pulley P as the pawl fits between the pulley P and the revolving arm *h*. The spring *s* attached to the pulley *i* bearing against the outer rim of the pulley P operates to throw the pawl into engagement with the internal ratchet, normally.

The hand rope Z is attached to the pulley P and the lower end of the hand rope is provided with a ring or knob suitable for the

quick attachment of a pole or extension hand rope when the hanger is to be operated.

The legs of each bracket B C are merged into lugs B' C' which serve the double purpose of binding posts and bearing feet for the brackets. On each bracket B C is mounted a contact spring *v* adapted to rub against the hub of the end plate *g* of the drum D. The end plate *g* is attached to the drum by means of two bolts *u u* screwed into plugs *t t* set in transverse holes in the drum. One end of these plugs at each end of the drum D is drilled out and has soldered into it the conductor cable *y* at that end. The circuit, then, in and out through the hanger, is by way of the binding posts B' C' and brackets B C, the spring *v*, the end plates *g*, the bolts *u*, plugs *t* and the conductor cables *y*.

To lower the lamp the operator connects his pole or extension rope to the lower end of the hand rope Z and pulls down until the lug *m* coming in contact with the lower end (as shown) of the pawl *i* throws the pawl out of engagement with the teeth of the ratchet. The weight of the lamp then comes on the pulley P and hand rope Z by reason of the revolving arm *h* resting against the lug *m* on the pulley P. The lamp is then lowered by an easy uniform slacking of the hand rope. To again suspend the lamp from the hanger after it is lowered to the desired position the operator gives the hand rope a quick full slack of half an inch or less, thereby allowing the tension of the spring *s* to react on the lug *m* momentarily, and bring the pawl *i* into engagement with the nearest tooth of the fixed ratchet *e*.

It should be observed that the allowable tension for the spring *s* is limited only by the weight of the lamp, so that the automatic action of the spring actuated pawl *i* is certain and secure. If the strength or tension of the spring *s* were greater than the weight of the lamp, the pawl could not be held clear of the teeth when lowering the lamp. To raise the lamp and suspend it, the same operations are performed as in lowering it.

Inasmuch as the wood work of lamp hangers is liable to have its insulating properties impaired by the action of moisture, vapor or acids, I have provided separate means for insulating the metallic brackets B C from the hanger board A. The insulating material used is preferably vitrified and glazed porcelain, although any other water and acid proof and non-combustible insulating material would answer.

The brackets B C are preferably insulated from the hanger board by means of a porcelain bushing *x* and a separator *w* of the same material through which passes the screw *w'* that holds the bracket B or C on the board A. The head of the screw is then covered with a water proof insulating wax *w''* which fills the countersunk hole formed in the board A.

Figs. 5 and 7 show modifications for accom-

plishing the same thing. In Fig. 5 a screw plug or bushing w^3 is employed in place of the bushing x and separator w shown in Fig. 6. In Fig. 7 an insulating plate w^4 of porcelain is secured by screws to the board A. The method first described and shown in Fig. 6 is however the preferable one for the reason that the bushing x and the separator w may be so designed or set as to clear each other and allow the wood of the board between the flange of the bushing and the separator to act as a cushion, as is clearly indicated in the drawings, thereby preventing in a great measure the breaking of the porcelain under strain.

To thoroughly insulate from each other the end plates g and current carrying parts on the ends of the drum D D, I divide this drum into two parts with a porcelain separator r . This separator is provided with a threaded shaft or axle r' r^2 adapted to screw into the bore of the drum.

I claim—

1. In an electric lamp hanger, the combination of a revolving lamp supporting drum and cables or lines wound upon the drum for supporting the lamp, a circular ratchet attached to the frame, a revolving spring actuated pawl normally held in engagement with said ratchet by the spring, a hand rope and connecting means for communicating motion from the hand rope to the pawl whereby the pawl may be operated or released and held free from the ratchet by means of the hand rope by pulling on the same, substantially as specified.

2. In an electric lamp hanger, the combination of a revolving lamp supporting drum and supporting cables, a frame upon which said drum is mounted, a circular ratchet attached to said frame, a revolving spring actuated pawl adapted to engage said ratchet, and means for operating and holding the pawl free from the ratchet, substantially as specified.

3. In an electric lamp hanger, the combination of the lamp and a revolving lamp supporting drum, with a frame upon which said drum is mounted, conductor cables wound upon the drum, a circular ratchet attached to said frame, a pivoted spring actuated pawl mounted upon a revolving arm connected rigidly with the drum, said pawl being adapted to engage said ratchet, a hand rope and means for communicating motion from the hand rope to the pawl to release and hold the same free from the ratchet, substantially as specified.

4. In an electric lamp hanger, the combination with a revolving lamp supporting drum and cables wound upon the drum for supporting the lamp, of a shaft for the drum, a frame upon which said shaft is journaled, a ratchet attached to said frame, a spring actuated pawl pivoted to a revolving part connected to said shaft and adapted to engage said ratchet, a hand rope and hand rope pulley

mounted upon said shaft and means for connecting the hand rope or its pulley with said pivoted pawl, whereby the pawl may be operated and held free from the ratchet by the hand rope, substantially as specified.

5. In an electric lamp hanger, the combination with a lamp supporting drum, of a hand rope drum or pulley, a common shaft upon which both said drums are mounted, a frame upon which said shaft is journaled, a ratchet secured to said frame, a pawl pivoted to a revolving part connected with said shaft, a spring for holding said pawl normally in engagement with said ratchet, said hand rope drum or pulley being loose upon said shaft and provided with a projection adapted to engage said pawl for the purpose of releasing the pawl from the ratchet, substantially as specified.

6. In an electric lamp hanger, the combination with a lamp supporting drum, of a hand rope drum or pulley, a common shaft upon which both said drums are mounted, a frame upon which said shaft is journaled, a ratchet secured to said frame, a pawl pivoted to a revolving part connected with said shaft, a spring for holding said pawl normally in engagement with said ratchet, said hand rope drum or pulley being loose upon said shaft and provided with a projection adapted to engage said pawl for the purpose of releasing the pawl from the ratchet, said hand rope drum or pulley being provided with a second flange or projection to limit the lost motion of said drum or pulley on said shaft, the lost motion being sufficient simply to operate or release the pawl, substantially as specified.

7. In an electric lamp hanger, the combination of a revolving lamp supporting drum, a shaft for the drum, a pawl mounted on a revolving part connected with the shaft, a spring for holding the pawl in engagement with the ratchet, a hand rope pulley mounted loosely upon the shaft or supporting frame, a ratchet attached to the frame to be engaged by the pawl, and means for positively operating the pawl and bringing the hand rope pulley into fixed engagement with the lamp supporting drum, substantially as specified.

8. In an electric lamp hanger the combination of the board A, metallic brackets B C secured thereto and insulated therefrom, with the two part conductor supporting drum D D, the two parts of said drum being insulated from each other and connected together by a separator r , metallic end plates $g g$ for said drum and springs $v v$ secured to said brackets B C and bearing against the metallic end plates $g g$ of said drum, substantially as specified.

9. The combination in an electric lamp hanger of the metallic brackets B C, insulating bushing x and separator w inserted in the connection between said brackets B C, and said hanger board A, drum shaft f journaled in said brackets B C, the two part conductor cable supporting drum D D, insulating sepa-

rator *r* connecting the two parts of said drum, conductor cables *y y* wound upon said drum, means for connecting the ends of said conductor cables *y y* with said metallic end plates *g g*, and springs *v* secured to said brackets B C and bearing against said metallic end plates, substantially as specified.

10. The combination in an electric lamp hanger, of the metallic brackets B C, insulating bushings *x* and separators *w* inserted in connection between said brackets B C and said hanger board A, drum shaft *f* journaled in said brackets B C, the two part conductor cable supporting drum D D, insulating separator *r* connecting the two parts of said drum, conductor cables *y y* wound upon said drum, means for connecting the ends of said conductor cables *y y* with said metallic end plates *g g*, springs *v* secured to said brackets B C and bearing against said metallic end plates *g g*, a ratchet *e* attached to one of said brackets, a pawl carrying arm *h* fixed to said shaft, a spring actuated pawl *i* pivoted to said arm *h*, a hand rope Z and hand rope pulley P provided with a projection or flange *m* adapted to engage and release said pawl *i*, substantially as specified.

11. The combination in an electric lamp hanger, of the metallic brackets B C, insulating bushing *x* and separator *w* inserted in the connection between said brackets B C and said hanger board A, drum shaft *f* journaled in said brackets B C, two part conductor cable supporting drum D D, insulating separator *r* connecting the two parts of said drum, conductor cables *y y* wound upon

said drum, means for connecting the ends of said conductor cables *y y* with said metallic end plates *g g*, springs *v* secured to said brackets B C, and bearing against said metallic end plates *g g*, the ratchet *e* attached to one of said brackets, a pawl carrying arm *h* fixed to said shaft, a spring actuated pawl *i* pivoted to said arm *h*, a hand rope Z and hand rope pulley P provided with a projection or flange *m* adapted to engage and release said pawl *i*, said hand rope pulley P having a second flange *n* to limit the lost motion of said hand rope pulley P in respect to said drum D D, substantially as specified.

12. The combination in an electric lamp hanger of the metallic brackets B, C, insulating bushing *x* and separator *w* inserted in the connection between said brackets B C, and said hanger board A, said brackets each forming part of the electric circuit, drum shaft *f* journaled in said brackets B C, the conductor cable supporting drum, conductor cables *y y* wound upon said drum, means for connecting the ends of said conductor cables *y y* with said metallic end plates *g g*, and springs *v* secured to said brackets B C and bearing against said metallic end plates whereby the hanger board is prevented from forming a short circuit between the two branches of the circuit under action of moisture or acids, substantially as specified.

WILLIAM S. WESTON.

Witnesses:

EMMA HACK,
H. M. MUNDAY.