

I. L. ROBBLEE.
 AUTOMOBILE CRANK.
 APPLICATION FILED SEPT. 23, 1910.

997,702.

Patented July 11, 1911.

2 SHEETS-SHEET 1.

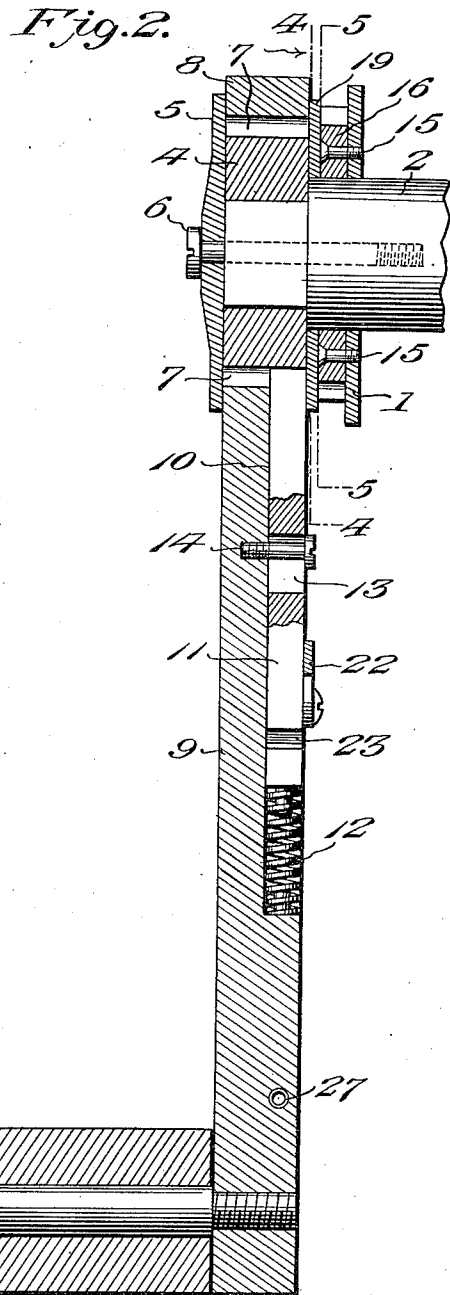
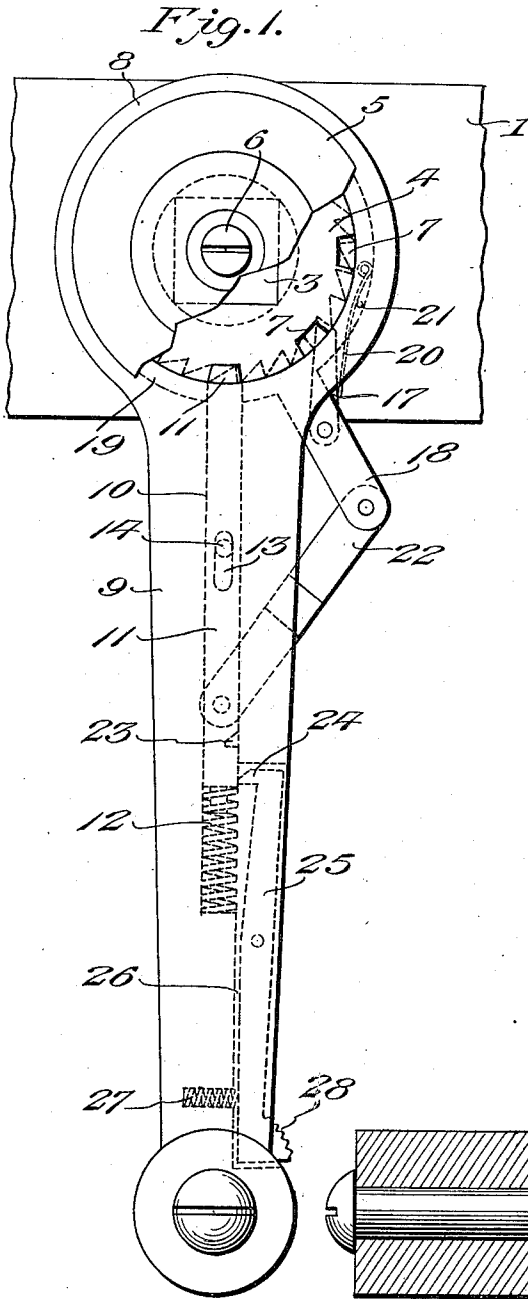

Inventor
I. L. Robblee

Witnesses

Edwin S. McKee
Edmund J. ...

334 *Victor J. Evans*
 Attorney

I. L. ROBBLEE.
AUTOMOBILE CRANK.

APPLICATION FILED SEPT. 23, 1910.

997,702.

Patented July 11, 1911.

2 SHEETS—SHEET 2.

Fig. 3.

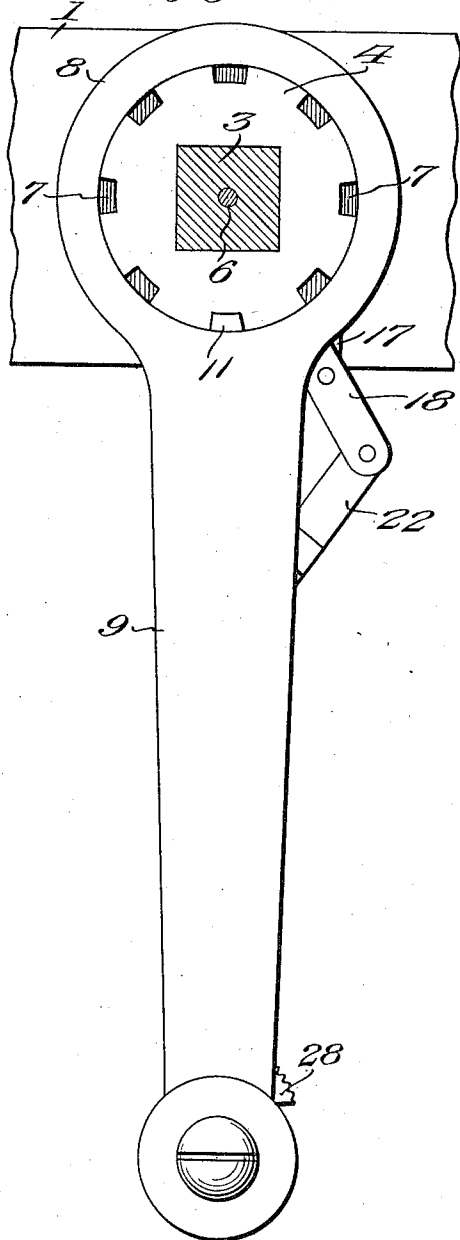

Fig. 4.

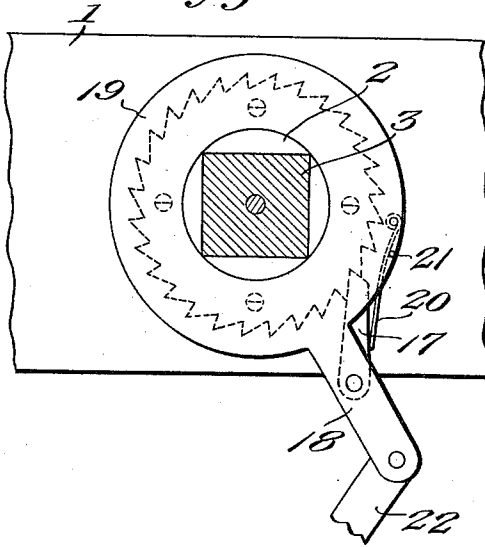
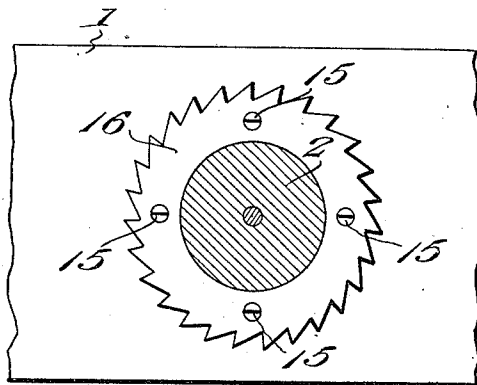

Fig. 5.



Witnesses

Edwin F. McKee
Edmond J. ...

Inventor

I. L. Robblee

By

Victor J. Evans

Attorney

UNITED STATES PATENT OFFICE.

IDE L. ROBBLEE, OF WOONSOCKET, RHODE ISLAND.

AUTOMOBILE-CRANK.

997,702.

Specification of Letters Patent. Patented July 11, 1911.

Application filed September 23, 1910. Serial No. 533,498.

To all whom it may concern:

Be it known that I, IDE L. ROBBLEE, a citizen of Canada, residing at Woonsocket, in the county of Providence and State of Rhode Island, have invented new and useful Improvements in Automobile-Cranks, of which the following is a specification.

This invention relates to cranks and more particularly to that type which are adapted for initially starting hydrocarbon engines.

The object of the invention is the provision of novel means for preventing sprained and broken arms and wrists by back firing.

A further object of the invention is the provision of novel means for clutching the crank to the crank shaft and for automatically releasing the crank from said shaft upon the occurrence of a back fire.

A still further object of the invention is the provision of means for locking the crank to the crank shaft for automatically releasing the same upon the occurrence of the back fire and for automatically locking the crank locking device in inoperative position.

Further objects of the invention will appear as the following specific description is read in connection with the accompanying drawing which forms a part of this application, and in which:

Figure 1 is a front elevation. Fig. 2 is a vertical longitudinal section. Fig. 3 is a front elevation with the retaining cap removed. Fig. 4 is a section on the line 4-4 of Fig. 2. Fig. 5 is a section on the line 5-5 of Fig. 2.

Referring more particularly to the drawing 1 represents the front plate of an automobile through which the crank shaft 2 of the engine passes. This shaft is provided with a squared end 3 upon which a clutch disk 4 is secured by means of a cap plate 5 which is seated against the end of the shaft and is held in position by a set screw 6 threaded longitudinally into the shaft 2. The clutch member 4 is provided with a plurality of notches 7 around its periphery for a purpose to be hereinafter described and surrounding the clutch member and adapted to rotate thereon is the collar 88 of the crank 9.

The rear side of the crank 9 is provided with a longitudinal channel 10 in which is slidably mounted a locking pin 11 which is normally pressed toward the clutch mem-

ber 4 by means of a spiral spring 12. The locking pin 11 is slotted at 13 and is held in position in the channel 10 by means of a headed stud 14 which passes through the slot and is threaded into the crank 9. This stud limits the movement of the locking pin and holds it in position to properly engage the notches in the clutch member 4.

Secured to the front plate 1 by means of the screws 15 and surrounding the shaft 2 is a toothed ratchet wheel 16 which is adapted to be engaged by a pawl 17 pivoted upon an arm 18 which projects from a collar 19 surrounding the shaft 2 between the ratchet wheel and the clutch member. This pawl is pressed into engagement with the ratchet wheel by means of a spring 20 which is pivoted upon the collar 19 and is held against the pawl by means of a pin 21. The arm 18 has its free end pivotally connected to a connecting link 22 which is in turn pivoted to the rear end of the locking pin 11.

The rear end of the locking pin is shown to be notched at 23 so as to receive the hook end 24 of a locking lever 25 pivoted to operate in a recess 26 formed in the upper part of the crank and normally forced into engagement with the locking pin by means of a spiral spring 27 which engages beneath its outer end. The extremity of the lever 25 opposite to the hook 24 is provided with a raised and serrated thumb piece 28 by which the hook 24 may be released from the notch 23. As shown the hook end 24 is beveled so as to permit the passage of the rear end of the locking pin by raising said hooked end against the tension of the spring 27. In the operation of the device, the crank is rotated with the pin 11 in engagement with one of the notches 7 so as to rotate the shaft 2, the pawl 17 riding idly over the teeth of the ratchet wheel 16. Upon the occurrence of a back fire, the pawl will enter one of the teeth, thus forcing the link 22 outwardly and pushing the locking pin 11 against the tension of the spring 12 and releasing it from the notch 7. This will permit the shaft 2 to rotate freely without the crank. When the pin 11 is forced to its rearward position, the rear end thereof will raise the hooked end of the lever 25 until said hooked end engages the notch 23 at which time it will be thrown into engagement therewith by the spring 27. The pin

11 is thereby locked in retracted position until it is released by a downward pressure upon the thumb piece 28.

5 Having thus described the invention, what is claimed is—

1. The combination with an engine shaft, of a clutch member mounted thereon, an operating crank rotatably mounted upon the clutch member, a locking pin carried by
10 the crank and adapted to engage the clutch member, means for normally holding the pin in engagement with the clutch member, means for automatically retracting the locking pin against the action of said holding
15 ing means, and means independent of the operator for locking said connecting pin in retracted position automatically.

2. The combination with an engine shaft, of a clutch member mounted thereon, an

operating crank surrounding said clutch 20 member, a stationary ratchet wheel surrounding said shaft, a pawl supporting member surrounding said shaft, a pawl thereon adapted to engage the ratchet wheel, a locking pin slidably mounted in the crank 25 and adapted to engage the clutch member, a connection between the locking pin and the pawl support which is adapted to retract the locking pin upon the reverse movement of the shaft and positive engagement of the 30 pawl with the ratchet wheel, and means to secure the locking pin in retracted position.

In testimony whereof I affix my signature in presence of two witnesses.

IDE L. ROBBLEE.

Witnesses:

WALTER R. RAY,
HUBERT K. BARRY.

Copies of this patent may be obtained for five cents each, by addressing the "Commissioner of Patents, Washington, D. C."