



(11) **EP 3 719 191 A1**

(12) **EUROPEAN PATENT APPLICATION**

(43) Date of publication:
07.10.2020 Bulletin 2020/41

(51) Int Cl.:
D04B 15/68 (2006.01) **D04B 15/32 (2006.01)**
D04B 15/70 (2006.01)

(21) Application number: **20167838.0**

(22) Date of filing: **02.04.2020**

(84) Designated Contracting States:
AL AT BE BG CH CY CZ DE DK EE ES FI FR GB GR HR HU IE IS IT LI LT LU LV MC MK MT NL NO PL PT RO RS SE SI SK SM TR
Designated Extension States:
BA ME
Designated Validation States:
KH MA MD TN

(71) Applicant: **SHIMA SEIKI MFG., LTD.**
Wakayama 641-8511 (JP)

(72) Inventor: **GOTO, Masanori**
Wakayama, 641-8511 (JP)

(74) Representative: **Emde, Eric**
Wagner & Geyer Partnerschaft mbB
Patent- und Rechtsanwälte
Gewürzmühlstrasse 5
80538 München (DE)

(30) Priority: **05.04.2019 JP 2019073176**

(54) **FLAT KNITTING MACHINE**

(57) A flat knitting machine that includes a plurality of needles 1 arranged on needle beds; a cam system that causes the needles 1 to perform a knitting operation, and needle selection actuators configured to select the needles 1. A select jack 3 of the needle 1 includes a first engaging portion 3A with which part of a selector 4 engages when the selector 4 moves from a bottom position to an intermediate position, and a second engaging portion 3B with which part of the selector 4 engages when the selector 4 moves from the bottom position to an advanced position. The cam system includes a switching cam 6 configured to sink the selection butt 31 into the needle groove 2g when switching the selector 4 from engaging with the first engaging portion 3A to engaging with the second engaging portion 3B. The switching cam 6 has a height in the protruding direction that is smaller than the height, in the protruding direction, of the fixing pressor 5.

Fig. 1

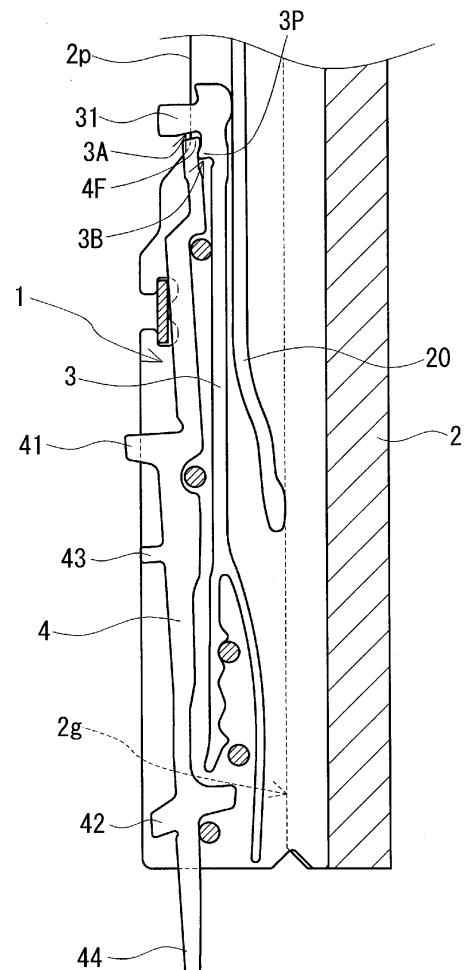

EP 3 719 191 A1

Description

Technical Field

[0001] The present invention relates to a flat knitting machine that is superior in knitting efficiency to conventional ones.

Background Art

[0002] Flat knitting machines are provided with: at least a front and a back needle bed; needles respectively arranged in multiple needle grooves formed side by side in the needle beds; and a carriage that reciprocates in the longitudinal direction of the needle beds (see, for example, Patent Literature 1 and the like). The carriage includes a cam system, and uses the cam system to move the needles forward and backward along the needle grooves, so that the needles perform a knitting operation for knitwear or the like.

[0003] The knitting operation is performed by controlling the movement of the needles using needle selection actuators, which are provided in the carriage together with the cam system. FIG. 8 is a schematic diagram showing a layout in which a needle 1 of a conventional flat knitting machine is arranged in a needle groove 2g formed in a needle bed 2. FIG. 9 is a schematic diagram showing cam systems 100 of the conventional flat knitting machine. FIG. 9 shows travel routes drawn on the cam systems 100 by some butts of a needle, when the cam systems 100 are moved leftward.

[0004] As shown in FIG. 8, the needle groove 2g in which the needle 1 is arranged is formed between a plurality of needle plates 2p arranged side by side on the needle bed 2. The needle 1 is prevented from quickly disengaging from the needle groove 2g by wires 2w and a steel band 2b that penetrate the needle plates 2p in the direction in which the needle plates 2p are arranged side by side. The needle 1 in this example includes a needle body 10, a needle jack 20, a select jack 30, and a selector 40. The needle body 10 has, at its leading end, a hook 11. The needle jack 20 is a member for moving the needle body 10 forward and backward in the direction in which the needle groove 2g extends, and has two knitting butts 21 and 22. The select jack 30 is a member for controlling the needle jack 20 to move forward or backward, and has, at its leading end, a selection butt 31. The selector 40 is a member for changing the position of the select jack 30 in the direction in which the needle groove 2g extends, and has a lowering butt 41, a raising butt 42, a needle selecting butt 43, and a tail 44.

[0005] On the other hand, as shown in FIG. 9, the cam systems 100 are provided protruding from a cam plate 101. FIG. 9 shows a double-cam system in which two cam systems 100 are provided on a single cam plate 101. The cam systems 100 protrude forward with respect to the paper plane, that is, orthogonally to the cam plate 101, and the needle 1 shown in FIG. 8 advances toward

a needle bed gap in the upper direction (gap side) with respect to the paper plane. Hereinafter, the forward direction of the cam systems 100 with respect to the paper plane is referred to as a "protruding direction", and the upper direction with respect to the paper plane is referred to as a "gap direction".

[0006] Each cam system 100 includes a knitting cam 80 and a transfer cam 81. The knitting cam 80 includes a needle raising cam, a stitch cam, and the like, and acts on the knitting butt 22 mainly when knitting and tucking. The transfer cam 81 acts on the knitting butt 21 when transferring stitches. The cam system 100 further includes a select jack lowering cam 82, an upper selector guiding cam 83, a lower selector guiding cam 84, a fixing pressor 85, a tuck pressor 86, a half pressor 87, a selector raising cam 88, a return cam 89, and the like. Also, the cam plate 101 includes four needle selection actuators 91, 92, 93, and 94.

[0007] The needle 1 shown in FIG. 8 is subjected to two-stage needle selection performed by the needle selection actuators 91, 92, 93, and 94 shown in FIG. 9, and performs a knitting operation based on the result of the needle selection and the state of the cam system 100. The needle selection for the needle 1 is performed by the selector 40 selected by the needle selection actuators 91, 92, 93, and 94 changing the position of the select jack 30 in the direction in which the needle groove 2g extends. The positions of the select jack 30 include three positions, namely, a B position, an H position located closer to the needle bed gap than the B position, and an A position located closer to the needle bed gap than the H position. In FIG. 9, the respective positions are denoted by "B", "H", and "A" enclosed by a square. On the other hand, the selector 40 can move to any one of three positions, namely, a bottom position, which corresponds to the B position of the select jack 30, an intermediate position, which corresponds to the H position, and an advanced position, which corresponds to the A position. In FIG. 9, for convenience, the bottom position, the intermediate position, and the advanced position of the selector 40 are denoted by "B", "H", and "A" enclosed by a square.

[0008] Changes in the positions of the select jack 30 and the selector 40 will be described with reference to FIG. 9. Here, a case is described as an example in which the cam systems 100 move leftward with respect to the paper plane, and needle selection is performed by two needle selection actuators 92 and 93 located at the center of the cam plate 101. FIG. 9 shows, the route of the selection butt 31 of the select jack 30 (FIG. 8), and the routes of the lowering butt 41, the raising butt 42, and the needle selecting butt 43 of the selector 40 (FIG. 8), from among the butts associated with needle selection.

[0009] First, the selector 40 at the B position is subjected to the first-stage needle selection performed by the needle selection actuator 92. When the actuator cam of the needle selection actuator 92 acts on the needle selecting butt 43, the tail 44 shown in FIG. 8 rotates to-

ward the needle groove 2g, and the raising butt 42 is sunk into the needle groove 2g. Thereafter, the lower selector guiding cam 84 can no longer act on the raising butt 42, and thus the selector 40 remains at the bottom position and the select jack 30 remains at the B position. The selection butt 31 still remaining at the B position is sunk into the needle groove 2g by the fixing pressor 85 located on the route of the selection butt 31. Then, the leading end portion of the select jack 30 curves the intermediate part of the needle jack 20, so that the knitting butt 22 is sunk into the needle groove 2g. Since the knitting cam 80 can no longer act on the knitting butt 22, the knitting operation is missing. The tail 44 shown in FIG. 8 is returned to the state shown in FIG. 8 by the return cam 89 before being subjected to needle selection performed by the needle selection actuator 94.

[0010] If the needle selection actuator 92 does not act on the needle selecting butt 43, the raising butt 42 remains protruding from the needle groove 2g, and is subjected to the action of the lower selector guiding cam 84. The lower selector guiding cam 84 is provided with two raising portions 84a, and the selector 40 is raised to the intermediate position by the raising portions 84a. Also, the leading end portion of the selector 40 pushes up the selection butt 31 of the select jack 30 to bring the selection butt 31 to the H position. The selection butt 31 raised by the second raising portions 84a remains at the H position, but the selector 40 is lowered to the bottom position by the upper selector guiding cam 83. As a result of the selector 40 being lowered to the bottom position, the needle selecting butt 43 can be subjected to needle selection performed by the second needle selection actuator 93.

[0011] Then, the selector 40 is subjected to the second-stage needle selection performed by the needle selection actuator 93. When the needle selection actuator 93 acts on the needle selecting butt 43, the selector 40 remains at the bottom position. The select jack 30 remains at the H position because it is not pushed up by the selector 40. The half pressor 87 and the tuck pressor 86 are provided on the route of the selection butt 31 at the H position.

[0012] On the other hand, unless the needle selection actuator 93 acts on the needle selecting butt 43, the raising butt 42 remains protruding from the needle groove 2g, and is pushed up by the selector raising cam 88. The selector 40 is raised to the advanced position, and the select jack 30 is raised to the A position by being pushed up by the selector 40. The selector 40 is immediately lowered to the bottom position by the upper selector guiding cam 83. After the knitting, the selection butt 31 is lowered to the B position by the select jack lowering cam 82 located on the right side with respect to the paper plane.

Citation List

Patent Literature

5 **[0013]** Patent Literature 1: WO 2007/074944A

Summary of Invention

Technical Problem

10 **[0014]** Recently, there is a demand for a further improvement in efficiency of knitting using flat knitting machines, and review of the shapes of existing needles and cam systems, and the like has been considered.

15 **[0015]** The present invention was made in view of the aforementioned circumstances, and it is an object thereof to provide a flat knitting machine that can further improve the knitting efficiency relative to conventional ones.

20 Solution to Problem

[0016] As a result of studying the aforementioned problems, the inventors of the present invention focused their attention on the fact that the selector is raised to the intermediate position after having been subjected to the first-stage needle selection, and is then lowered once to the bottom position. In such a configuration, when the selector that has been subjected to the second-stage needle selection is raised from the bottom position to the advanced position, there is an idle state in which the selector does not push up the select jack at all, during the movement of the selector from the bottom position to the intermediate position. In other words, when the selector is in the idle state, the selector unnecessarily moves, and due to the unnecessary movement, the selector raising cam has a large height in the gap direction (upper direction with respect to the paper plane). In view thereof, the present inventors arrived at the idea that reducing the distance for which the selector idles can reduce the height, in the gap direction, of the selector raising cam, and accomplished the flat knitting machine of the present invention.

[0017] According to an aspect of the present invention, a flat knitting machine includes:

45 at least a front and a back needle bed;
a plurality of needles respectively arranged in a plurality of needle grooves formed in the needle beds;
a cam system configured to move the needles forward and backward in a direction along the needle grooves, so that the needles perform a knitting operation; and
needle selection actuators configured to perform needle selection on the needles to,
50 each of the needles including:

a select jack having a selection butt that is subjected to the action of the cam system, the select

jack being configured to cause the needle to perform different knitting operations; and a selector configured to change the position of the select jack along the needle groove,

the select jack being configured to move to any of a B position, an H position, and an A position, based on a result of the needle selection performed by the needle selection actuators, the selector being configured to move to any of a bottom position that corresponds to the B position, an intermediate position that corresponds to the H position, and an advanced position that corresponds to the A position, the cam system including:

a fixing pressor configured to sink the selection butt at the B position into the needle groove; and a select jack lowering cam configured to bring the selection butt at the H position or the A position to the B position,

wherein the select jack includes:

a first engaging portion with which part of the selector engages when the selector moves from the bottom position to the intermediate position; and a second engaging portion with which part of the selector engages when the selector moves from the bottom position to the advanced position,

the cam system includes

a switching cam that is provided along an edge portion of the select jack lowering cam, and is configured to sink the selection butt into the needle groove when switching the selector from engaging with the first engaging portion to engaging with the second engaging portion, and the switching cam has a height in a protruding direction that is smaller than the height, in a protruding direction, of the fixing pressor.

[0018] As an aspect of the flat knitting machine of the present invention, the select jack may include a protruding portion that protrudes to a back end side of the needle from a base portion, on the back end side, of the selection butt,

the first engaging portion is constituted by an end surface, on the back end side, of the selection butt, and the second engaging portion is constituted by an end surface, on the back end side, of the protruding portion.

[0019] As an aspect of the flat knitting machine of the present invention, the flat knitting machine may further include a coupling portion provided at an end, in an extending direction, of the fixing pressor, and is configured to come close to the switching cam, wherein a height, in a protruding direction, of the coupling

portion conforms to the height, in the protruding direction, of the switching cam.

Advantageous Effects of Invention

5

[0020] In the select jack of the flat knitting machine according to the present invention, the selector engages with the select jack at different positions between when the selector moves from the bottom position to the intermediate position, and when the selector moves from the bottom position to the advanced position. Accordingly, it is possible to reduce the idle distance of the selector when the selector moves from the bottom position to the advanced position. As a result, the distance for which the selector moves from the bottom position to the advanced position can be reduced. The fact that the moving distance of the selector can be reduced means that the height, in the gap direction, of the selector raising cam that pushes up the selector to the advanced position can be reduced, making it possible to also reduce the length, in the moving direction, of the cam system. Therefore, the reciprocating stroke of the carriage can be reduced, leading to an improvement in the knitting efficiency. Also, due to the reduction in the length, in the moving direction, of the cam system, downsizing and a reduction in the weight of the carriage can be realized, leading to an improvement in the knitting speed.

10

[0021] Furthermore, in the flat knitting machine of the present invention, the select jack that has been pushed up by the selector and brought to the H position is sunk into the needle groove by the switching cam provided in the vicinity of the select jack lowering cam, so that the selector and the select jack are separated from each other in the depth direction of the needle groove. As a result of the selector moving to the bottom position at this timing, and advancing again to the gap side, the engagement of the selector with the first engaging portion of the select jack is shifted to the engagement with the second engaging portion at an appropriate timing. Also, it is possible to prevent the selector and the select jack from interfering with each other when the engagement is shifted, and thus the shift of engagement is highly unlikely to fail.

15

[0022] By providing the protruding portion at the base of the selection butt of the select jack, and providing both the first engaging portion and the second engaging portion in the vicinity of the selection butt, the selector pushes up the select jack in a reliable manner. If the selector pushes up the select jack at a position close to the selection butt, it is possible to suppress the select jack from rotating in the direction in which the selection butt is sunk into the needle groove.

20

[0023] By providing the coupling portion at an end, in the extending direction, of the fixing pressor, and setting the height, in the protruding direction, of the coupling portion so as to conform to the height, in the protruding direction, of the switching cam, it is possible to smoothly move the selection butt from the fixing pressor to the switching cam when the select jack moves from the B

25

30

35

40

45

50

55

position to the H position.

Brief Description of Drawings

[0024]

FIG. 1 is a schematic diagram illustrating a state in which a select jack and a selector of a needle of a flat knitting machine according to Embodiment 1 are arranged in a needle groove.

FIG. 2 is a schematic diagram illustrating part of central portion of a double-cam system included in the flat knitting machine according to Embodiment 1.

FIGS. 3 are schematic diagrams illustrating positional relationships between the select jack and the selector in the main portion shown in FIG. 2.

FIG. 4 is a schematic diagram illustrating part of an end portion of the double-cam system included in the flat knitting machine of Embodiment 1.

FIGS. 5 are schematic diagrams illustrating positional relationships between a select jack and a selector of a flat knitting machine according to Embodiment 2.

FIGS. 6 are schematic diagrams illustrating positional relationships between a select jack and a selector of a flat knitting machine according to Embodiment 3.

FIG. 7 is a schematic diagram illustrating part of a cam system included in a flat knitting machine according to Embodiment 4.

FIG. 8 is a schematic diagram illustrating a state in which a needle is arranged in a needle groove formed in a needle bed of a conventional flat knitting machine.

FIG. 9 is a schematic diagram illustrating a cam system of the conventional flat knitting machine.

Description of Embodiments

[0025] Hereinafter, embodiments of the present invention will be described with reference to the drawings. The flat knitting machine of the present invention differs from the conventional flat knitting machine in a part of the needles and a part of the cam systems. The configurations having the same functions as those of the conventional flat knitting machines are denoted by the same reference signs as those in FIGS. 8 and 9, and detailed description thereof is omitted.

Embodiment 1

[0026] The needle 1 arranged in the needle groove 2g shown in FIG. 1 differs from the conventional needle in the configuration of a select jack 3. The select jack 3 has a protruding portion 3P that protrudes from the base portion of a selection butt 31 formed at the leading end of the select jack 3 toward the back end of the needle 1 (lower side with respect to the paper plane). In the select jack 3, an end surface of the selection butt 31 on the back end side of the needle 1 functions as a first engaging

portion 3A for engaging with a leading end portion 4F of the selector 4. The first engaging portion 3A is a portion with which the leading end portion 4F of the selector 4 engages when the selector 4 moves from a bottom position to an intermediate position. As a result of the first engaging portion 3A being pushed up by the selector 4, the select jack 3 moves from a B position to an H position.

[0027] Furthermore, in the select jack 3 of this example, an end surface of the protruding portion 3P on the back end side of the needle 1 functions as a second engaging portion 3B for engaging with the leading end portion 4F of the selector 4. In other words, the second engaging portion 3B is located at a position that is closer to the back end side of the needle 1 than the first engaging portion 3A is, and is shifted to the bottom side of the needle groove 2g. The second engaging portion 3B is a portion with which the leading end portion 4F of the selector 4 engages when the selector 4 moves from the bottom position to an advanced position. As a result of the second engaging portion 3B being pushed up by the selector 4, the select jack 3 moves from the H position to an A position. The distance between the first engaging portion 3A and the second engaging portion 3B in the longitudinal direction of the needle 1 is slightly smaller (by about 1 mm or smaller) than the distance from the bottom position to the intermediate position of the selector 4. Therefore, the selector 4 can move between the first engaging portion 3A and the second engaging portion 3B smoothly.

[0028] On the other hand, the selector 4 of this example has the same configuration as that of the conventional selector 40 shown in FIG. 8.

[0029] The following will describe the cam system 100 of this example with reference to FIG. 2. FIG. 2 shows only the portion of the cam system 100 that is involved in needle selection. Furthermore, FIG. 2 is used to describe an example in which the select jack 3 moves to the H position due to first-stage needle selection, and moves to the A position due to second-stage needle selection. FIG. 2 only shows the routes of the selection butt 31 and the raising butt 42 in this example. The configurations of a fixing pressor 5 and a selector raising cam 8 of the cam system 100 of this example are different from those of the conventional flat knitting machine. Furthermore, the cam system 100 of this example includes a switching cam 6 that is not provided in the conventional flat knitting machine.

[0030] The switching cam 6 is provided along the lower-side edge portion of a select jack lowering cam 82. In this example, the switching cam 6 is separated from the select jack lowering cam 82, but may be formed as one piece therewith. The switching cam 6 is provided with a body portion 60 that is parallel to a cam plate 101 (see FIG. 9), and slope portions 61 formed at both ends of the body portion 60. The height, in the protruding direction (forward direction with respect to the paper plane), of the body portion 60 of the switching cam 6 is uniform, and is smaller than the height, in the protruding direction, of the

fixing pressor 5. The slope portions 61 have a surface that is gradually inclined upward from the cam plate 101 toward the body portion 60. The width of the body portion 60 is set to be equal to that of an area in which two raising portions 84a are formed, or slightly larger or smaller than this area. With this configuration, the body portion 60 can act on the selection butt 31 such that the leading end portion 4F of the selector 4 that is raised by the raising portions 84a does not engage with the second engaging portion 3B. The area in which the raising portions 84a are formed refers to the distance area between the position at which the raising butt 42 comes into contact with the left raising portion 84a, and the position at which the raising butt 42 comes into contact with the right raising portion 84a when the carriage moves in the direction opposite to that in this example.

[0031] This switching cam 6 is configured to sink the selection butt 31 of the select jack 3 (FIG. 1) pushed up by the selector 4 and moved to the H position into the needle groove 2g. With the switching cam 6, the selection butt 31 is sunk into the needle groove 2g to the extent such that part of the selection butt 31 protrudes from the needle groove 2g. As a result, the switching cam 6 separates the select jack 3 and the selector 4 from each other in the depth direction of the needle groove 2g. Details thereof will be described later with reference to FIG. 3.

[0032] The fixing pressor 5 includes intermediate portions 50 that are parallel to the cam plate 101, and coupling portions 51 formed at both ends, in the extending direction, of the intermediate portions 50. The coupling portions 51 are shorter in height than the intermediate portions 50. The height, in the protruding direction, of the coupling portions 51 conforms to the height, in the protruding direction, of the switching cam 6 (body portion 60). Each intermediate portion 50 is coupled to the coupling portions 51 by inclined portions 52 that each have a slope surface (indicated by "x" in the figure) inclined downward from the intermediate portion 50 toward the corresponding coupling portion 51. The coupling portions 51 and the inclined portions 52 may also be separated from the fixing pressor 5. It is sufficient that the height, in the protruding direction, of the coupling portions 51 conforms to the height, in the protruding direction, of the switching cam 6 such that the selection butt 31 can smoothly move without interfering with the boundary between the fixing pressor 5 and the switching cam 6. For example, the difference in the height in the protruding direction between the coupling portions 51 and the switching cam 6 is preferably 1 mm or smaller (including 0 mm).

[0033] The height, in the gap direction (upper direction with respect to the paper plane), of the selector raising cam 8 is smaller than that of the conventional selector raising cam 88 shown in FIG. 9. This is the effect obtained by the select jack 3 shown in FIG. 1 including the first engaging portion 3A and the second engaging portion 3B. With a small height in the gap direction of the selector

raising cam 8, the knitting cam 80 (FIG. 9) can be provided closer to the select jack lowering cam 82. This can realize a reduction in the length, in the moving direction, of the cam system 100, and a reduction in the reciprocating stroke of the carriage. Also, with a reduced length in the moving direction of the carriage, the weight of the carriage can be reduced, which increases the moving speed of the carriage. As a result, the knitting time is reduced, and the knitting efficiency is improved.

[0034] Here, the height, in the gap direction, of the selector raising cam 8 can be set to be, for example, 1 to 1.6 times inclusive as large as the height, in the gap direction, of the raising portions 84a of the lower selector guiding cam 84. The height, in the gap direction, of the selector raising cam 8 (raising portions 84a) refers to the distance from a reference position to the top of the selector raising cam 8 (raising portions 84a), the reference position being the position at which the raising butt 42 at the bottom position first comes into contact. In contrast, it is not possible to set the height, in the gap direction, of the conventional selector raising cam 88 shown in FIG. 9 to be 1.6 times or less as large as the height in the gap direction of the raising portion 84a.

[0035] The following will describe, with reference to FIGS. 3, the positional relationship between the select jack 3 and the selector 4 when the select jack 3 moves to the H position due to the first-stage needle selection, and to the A position due to the second-stage needle selection. FIGS. 3(A) to 3(F) respectively correspond to the vertical dashed lines denoted by capital letters A to F shown in FIG. 2.

[0036] In FIG. 3(A), the select jack 3 is at the B position, and the selection butt 31 of the select jack 3 is sunk into the needle groove 2g by the intermediate portion 50 of the fixing pressor 5. On the other hand, the selector 4 is at the bottom position, and the leading end portion 4F of the selector 4 is not pushing up the selection butt 31.

[0037] In FIG. 3(B), the selection butt 31 abuts against the inclined portion 52 of the fixing pressor 5, and is slightly raised from the needle groove 2g relative to the state shown in FIG. 3(A). The body portion 60 of the switching cam 6 is present on the gap side (upper side with respect to the paper plane) of the inclined portion 52.

[0038] In FIG. 3(C), as a result of the selector 4 moving to the intermediate position, the leading end portion 4F of the selector 4 pushes up the first engaging portion 3A of the select jack 3, and the select jack 3 is moved to the H position and is arranged on the body portion 60 of the switching cam 6. The selection butt 31 of the select jack 3 is pushed by the switching cam 6 so that almost half of the selection butt 31 is sunk in the needle groove 2g. Accordingly, the select jack 3 and the selector 4 are separated from each other in the depth direction (left-right direction with respect to the paper plane) of the needle groove 2g.

[0039] In FIG. 3(D), the selector 4 is once returned to the bottom position. At this time, since the select jack 3 and the selector 4 are separated from each other in the

depth direction of the needle groove 2g, the selector 4 is not likely to interfere with the select jack 3 when moving. Accordingly, the select jack 3 does not move in an unintended manner, and the select jack 3 remains at the H position. In the zones between FIGS. 3(B) to 3(D), that is, the zone in which the select jack 3 moves to the H position due to the first-stage needle selection, the selection butt 31 moves while being sunk by the body portion 60.

[0040] In FIG. 3(E), the selection butt 31 has passed by the switching cam 6, and is raised from the needle groove 2g. Therefore, the portion of the select jack 3 on its leading end side and the selector 4 come close to each other in the depth direction of the needle groove 2g so that the leading end portion 4F of the selector 4 faces and is close to the second engaging portion 3B of the select jack 3.

[0041] In FIG. 3(F), as a result of the selector 4 moving to the advanced position, the leading end portion 4F of the selector 4 pushes up the second engaging portion 3B, and the select jack 3 is moved to the A position. Here, as shown in FIG. 3(E), at a point in time at which the selector 4 is at the bottom position, the leading end portion 4F of the selector 4 is already close to the second engaging portion 3B of the select jack 3 at the H position. Accordingly, in FIG. 3(F), the distance for which the selector 4 idles is significantly reduced, and the distance for which the selector 4 is moved from the bottom position to the advanced position is also reduced.

[0042] The following will describe a configuration of a switching cam 6 that corresponds to the needle selection actuator 94 located at an end of the carriage, with reference to FIG. 4. At the end of the carriage, when the carriage moves leftward with respect to the paper plane, the first-stage needle selection is performed by the needle selection actuator 94. Then, when the carriage is returned and moved rightward with respect to the paper plane, the second-stage needle selection is performed by the needle selection actuator 94. When the carriage is returned after the first-stage needle selection, the selector is lowered to the bottom position by the upper selector guiding cam 83, is raised to the intermediate position by the raising portion 84a on the left side of the paper plane, and then is subjected to the second-stage needle selection. FIG. 4 only shows the routes of the selection butt 31 and the raising butt 42 during the first-stage needle selection.

[0043] At the end of the carriage shown in FIG. 4, the switching cam 6 is also provided along the edge portion of the select jack lowering cam 82. Also with this switching cam 6, shifting of engagement between the select jack 3 and the selector 4 as described with reference to FIG. 3 can also be performed, and thus the height, in the gap direction, of the selector raising cam 8 can be reduced relative to that in the conventional configuration.

[0044] Note however that, at the end of the carriage, the selector 4 subjected to the first-stage needle selection remains at the intermediate position. The selector 4 at

the intermediate position is supported by the wires 2w, as shown in FIG. 3(C), for example. Therefore, even if, after completion of the first-stage needle selection, an operator stops the carriage for maintenance and touches the selector 4, the selector 4 will not be sunk into the needle groove 2g. Accordingly, even if the running of the carriage is restarted after the maintenance, no trouble will occur in the second-stage needle selection.

[0045] Here, in contrast to FIGS. 2 and 4, there are also cases where the first-stage needle selection is performed in a state in which the selection butt 31 is at the H position or the A position. In this case, the selection butt 31 runs over the body portion 60 via the slope portion 61. Then, the selection butt 31 is lowered by the select jack lowering cam 82 to the B position. At this time, the body portion 60 of the switching cam 6 sinks the selection butt 31, and the second engaging portion 3B and the leading end portion 4F are shifted from each other in the depth direction of the needle groove 2g. This can prevent the second engaging portion 3B from colliding and engaging with the leading end portion 4F of the selector 4 when the select jack 3 is lowered to the B position.

Embodiment 2

[0046] Embodiment 2 will describe an example in which the shapes of the select jack 3 and the selector 4 are different from those of Embodiment 1, with reference to FIGS. 5. FIGS. 5(B) to 5(F) respectively correspond to the vertical dashed lines denoted by capital letters B to F shown in FIG. 2.

[0047] As shown in FIG. 5(B), in the select jack 3 of this example, one of the bifurcated back ends that is located on the opening side of the needle groove 2g serves as a first engaging portion 3A. Furthermore, in the select jack 3 of this example, the end surface of the protruding portion 3P on the back end side of the needle 1 serves as a second engaging portion 3B, similar to Embodiment 1.

[0048] In FIG. 5(C), the selector 4 is moved to the intermediate position. At this time, the first engaging portion 3A of the select jack 3 is pushed up by an engaging projection 45 of the selector 4 that projects to the side (bottom side of the needle groove 2g) opposite to the raising butt 42. As a result, the select jack 3 is also moved to the H position. The selection butt 31 of the select jack 3 is arranged on the switching cam 6.

[0049] In FIG. 5(D), the selector 4 returns to the bottom position. In FIG. 5(E), the selection butt 31 is moved to a position at which the switching cam 6 is not present (see the vertical dashed line E in FIG. 2), and thus the selection butt 31 is raised from the needle groove 2g. As a result, the leading end portion 4F of the selector 4 engages with the second engaging portion 3B. The first engaging portion 3A is separated from the engaging projection 45.

[0050] In FIG. 5(F), the selector 4 is moved from the bottom position to the advanced position, and the select

jack 3 pushed up by the leading end portion 4F is also moved to the A position. Referring to FIGS. 5(E) and 5(F), it is clear that, also with the configuration of this example, there is hardly any idle distance for which the selector 4 idles.

Embodiment 3

[0051] Embodiment 3 will describe an example in which the shapes of the select jack 3 and the selector 4 are different from those of Embodiments 1 and 2, with reference to FIGS. 6. FIGS. 6(B) to 6(F) respectively correspond to the vertical dashed lines denoted by capital letters B to F shown in FIG. 2.

[0052] As shown in FIG. 6(B), similar to Embodiment 1, in the select jack 3 of this example, the end surface of the selection butt 31 on the back end side of the needle 1 serves as the first engaging portion 3A. Furthermore, in the select jack 3 of this example, the protruding second engaging portion 3B is formed at a position in an intermediate part of the select jack 3 that is only slightly on the A position side. The second engaging portion 3B protrudes to the selector 4 side (opening side of the needle groove 2g). On the other hand, the selector 4 has an engaging projection 4p at a position in an intermediate part of the selector 4 that is only slightly on the advanced position side. When the select jack 3 is at the B position and the selector 4 is at the bottom position, the engaging projection 4p is arranged on the A position side of the second engaging portion 3B. The engaging projection 4p and the second engaging portion 3B are separated from each other in the depth direction of the needle groove 2g.

[0053] In FIG. 6(C), the selector 4 is moved to the intermediate position. At this time, the first engaging portion 3A of the select jack 3 is pushed up by the leading end portion 4F of the selector 4. As a result, the select jack 3 is also moved to the H position. The selection butt 31 of the select jack 3 is arranged on the switching cam 6.

[0054] In FIG. 6(D), the selector 4 returns to the bottom position. As a result of the selector 4 returning to the bottom position, the positions, in the gap direction, of the engaging projection 4p and the second engaging portion 3B are replaced by each other, and the engaging projection 4p is arranged further on the back side of the needle 1 than the second engaging portion 3B. At this time, since the selection butt 31 is pushed by the switching cam 6, and the separation distance between the select jack 3 and the selector 4 is kept as is, the engaging projection 4p and the second engaging portion 3B are prevented from interfering with each other.

[0055] In FIG. 6(E), the selection butt 31 is disengaged from the switching cam 6, and the selection butt 31 is raised from the needle groove 2g. At this time, the engaging projection 4p and the second engaging portion 3B are arranged at positions at which they can engage with each other in the depth direction of the needle groove 2g. Accordingly, the engaging projection 4p of the selector 4 engages with the second engaging portion 3B. The

first engaging portion 3A is separated from the leading end portion 4F.

[0056] In FIG. 6(F), the selector 4 is moved from the bottom position to the advanced position, and the select jack 3 pushed up by the engaging projection 4p is moved to the A position. Referring to FIGS. 6(E) and 6(F), it is clear that, also with the configuration of this example, there is hardly any idle distance for which the selector 4 idles.

Embodiment 4

[0057] Embodiment 4 will describe an example in which the shapes of the upper selector guiding cam 83, the lower selector guiding cam 84, and the select jack lowering cam 82 are different from those of Embodiment 1, with reference to FIG. 7. The functions of the cams 82, 83, and 84 are the same as those of Embodiment 1.

[0058] The lower selector guiding cam 84 of this example includes only one raising portion 84a. Conforming to this shape of the lower selector guiding cam 84, the upper selector guiding cam 83 is shaped so as to be able to return the lowering butt 41 to the B position.

[0059] On the other hand, the select jack lowering cam 82 is shaped such that an intermediate part thereof is recessed in the gap direction (upper direction with respect to the paper plane). Both end portions of the recessed portion respectively have slope surfaces that are raised in the protruding direction (forward direction with respect to the paper plane) from the intermediate part toward the two ends. The width of the recessed portion excluding the slope surfaces is set to be equal to that of an area in which the raising portion 84a is formed, or slightly larger or smaller than this area, so that the selection butt 31 moving from the B position to the H position does not interfere with the slope surfaces. Therefore, the selection butt 31 at the H position can pass by the select jack lowering cam 82 while remaining at the H position.

[0060] The above-described configuration may also employ the switching cam 6 described in Embodiment 1. Similar to Embodiment 1, the switching cam 6 is arranged along the edge portion of the select jack lowering cam 82, and contributes to shifting of the engagement position between the select jack 3 and the selector 4.

Other Embodiment

[0061] Although, Embodiments 1 to 4 have described examples in which the mechanical needle selection actuators 91, 92, 93, and 94 each having an actuator cam are used, the needle selection actuators 91, 92, 93, and 94 may also be of an electromagnetic absorbing type as disclosed in JP 3459514B.

Claims

1. A flat knitting machine comprising:

at least a front and a back needle bed (2);
 a plurality of needles (1) respectively arranged
 in a plurality of needle grooves (2g) formed in
 the needle beds (2);
 a cam system (100) configured to move the needles (1) forward and backward in a direction
 along the needle grooves (2g), so that the needles (1) perform a knitting operation; and
 needle selection actuators (91, 92, 93, 94) configured to perform needle selection on the needles (1),
 each of the needles (1) including:

a select jack (3) having a selection butt (31) that is subjected to the action of the cam system (100), the select jack (3) being configured to cause the needle (1) to perform different knitting operations; and
 a selector (4) configured to change the position of the select jack (3) along the needle groove (2g),

the select jack (3) being configured to move to any of a B position, an H position, and an A position, based on a result of the needle selection performed by the needle selection actuators (91, 92, 93, 94),

the selector (4) being configured to move to any of a bottom position that corresponds to the B position, an intermediate position that corresponds to the H position, and an advanced position that corresponds to the A position,
 the cam system (100) including:

a fixing pressor (5) configured to sink the selection butt (31) at the B position into the needle groove (2g); and
 a select jack lowering cam (82) configured to bring the selection butt (31) at the H position or the A position to the B position,

wherein the select jack (3) includes:

a first engaging portion (3A) with which part of the selector (4) engages when the selector (4) moves from the bottom position to the intermediate position; and
 a second engaging portion (3B) with which part of the selector (4) engages when the selector (4) moves from the bottom position to the advanced position,

the cam system (100) includes
 a switching cam (6) that is provided along an edge portion of the select jack lowering cam (82), and is configured to sink the selection butt (31) into the needle groove (2g) when switching the selector (4) from engaging with the first en-

gaging portion (3A) to engaging with the second engaging portion (3B), and
 the switching cam (6) has a height in a protruding direction that is smaller than the height, in a protruding direction, of the fixing pressor (5).

2. The flat knitting machine according to claim 1, wherein the select jack (3) includes a protruding portion (3P) that protrudes to a back end side of the needle (1) from a base portion, on the back end side, of the selection butt (31),
 the first engaging portion (3A) is constituted by an end surface, on the back end side, of the selection butt (31), and
 the second engaging portion (3B) is constituted by an end surface, on the back end side, of the protruding portion (3P).

3. The flat knitting machine according to claim 1 or 2, further comprising
 a coupling portion (51) provided at an end, in an extending direction, of the fixing pressor (5), and is configured to come close to the switching cam (6), wherein a height, in a protruding direction, of the coupling portion (51) conforms to the height, in the protruding direction, of the switching cam (6).

Fig. 1

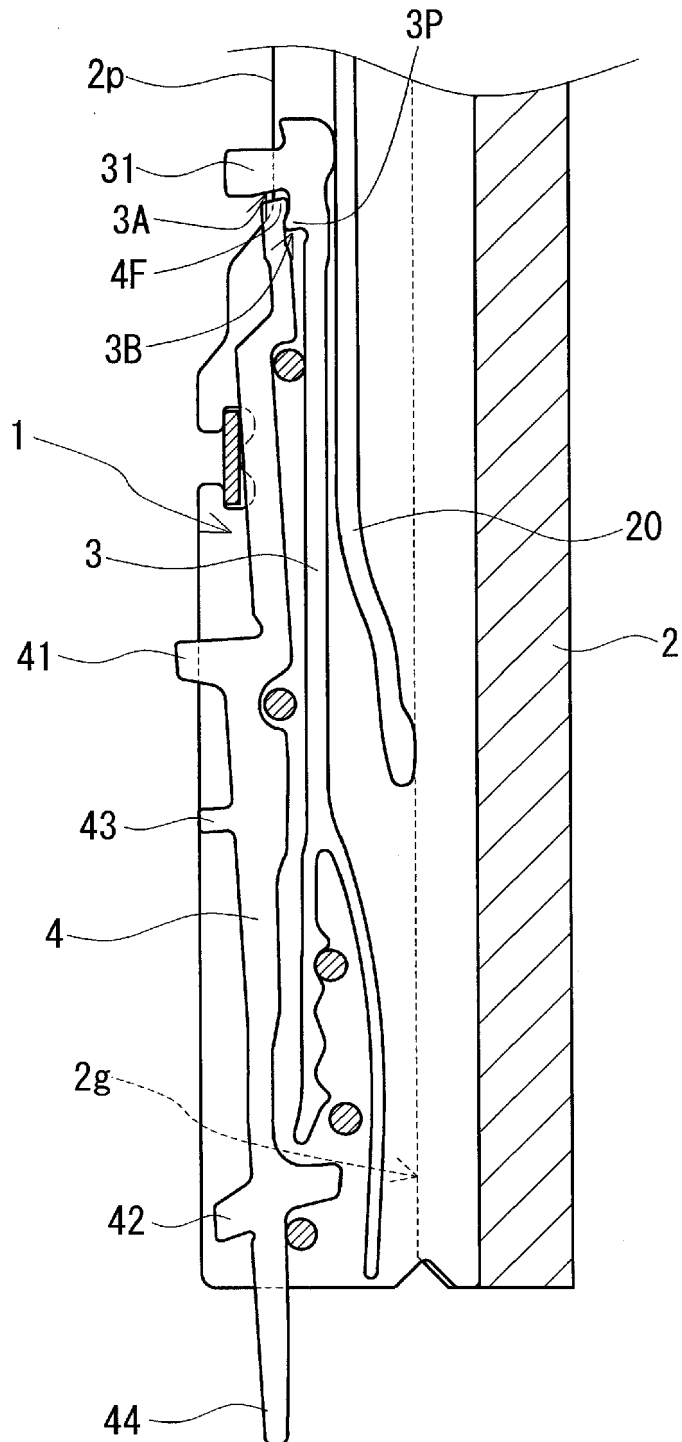

Fig. 2

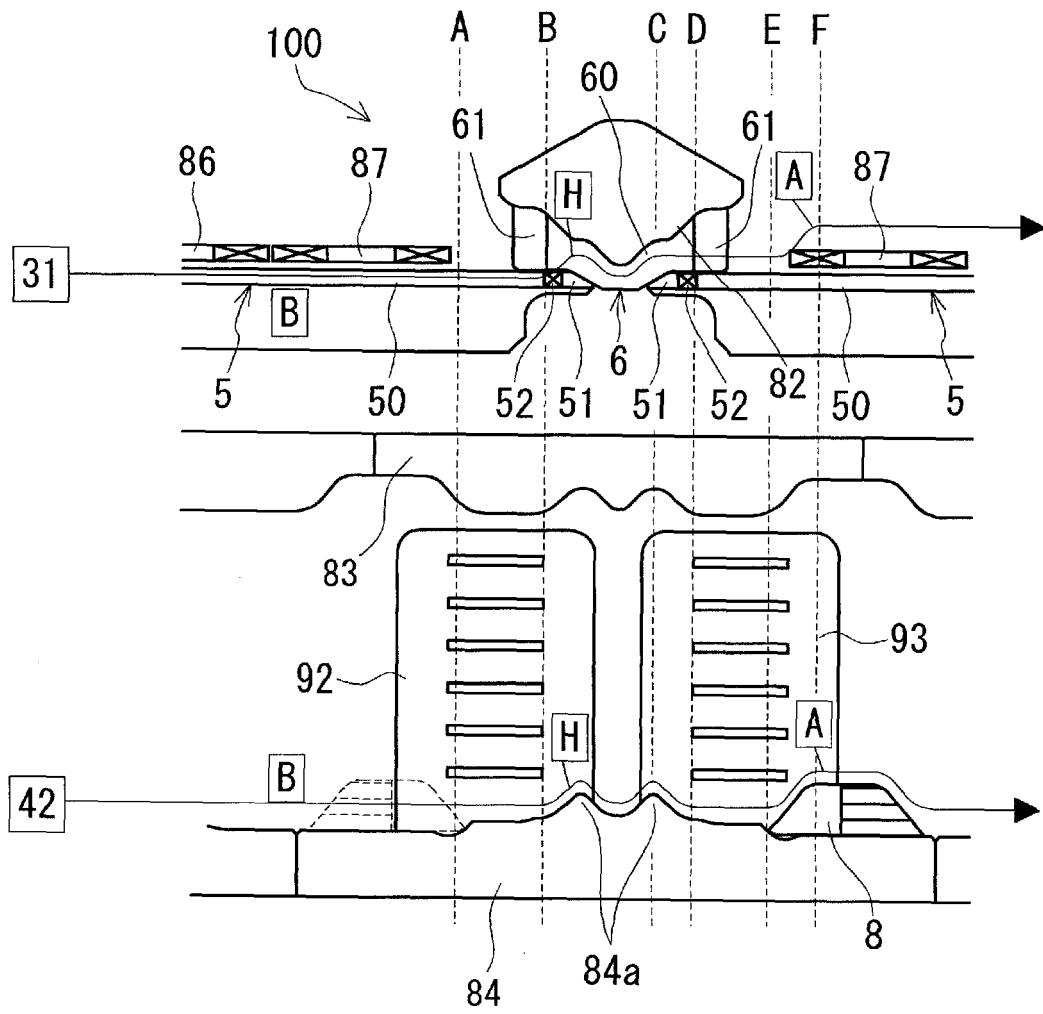

Fig. 3

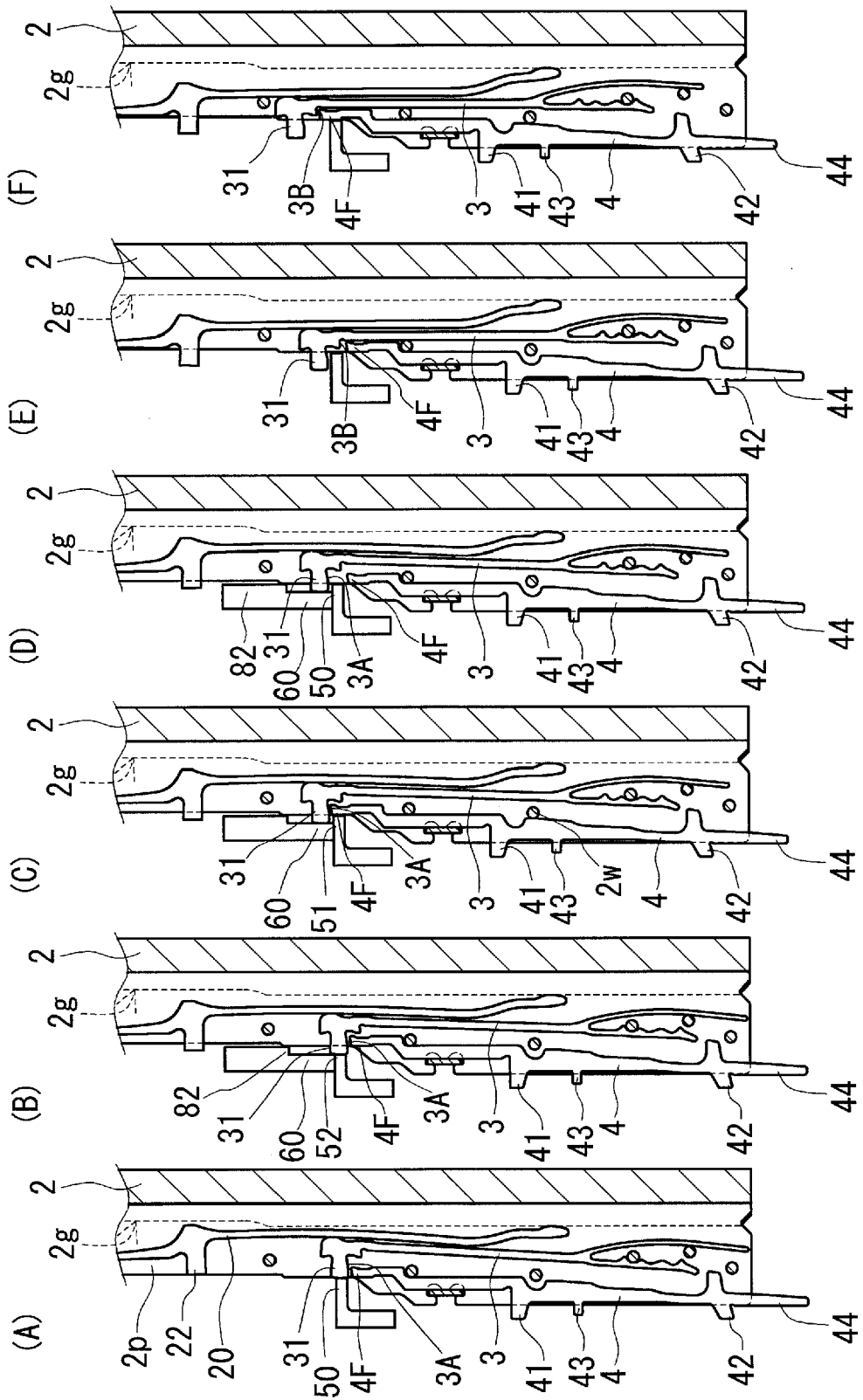

Fig. 4

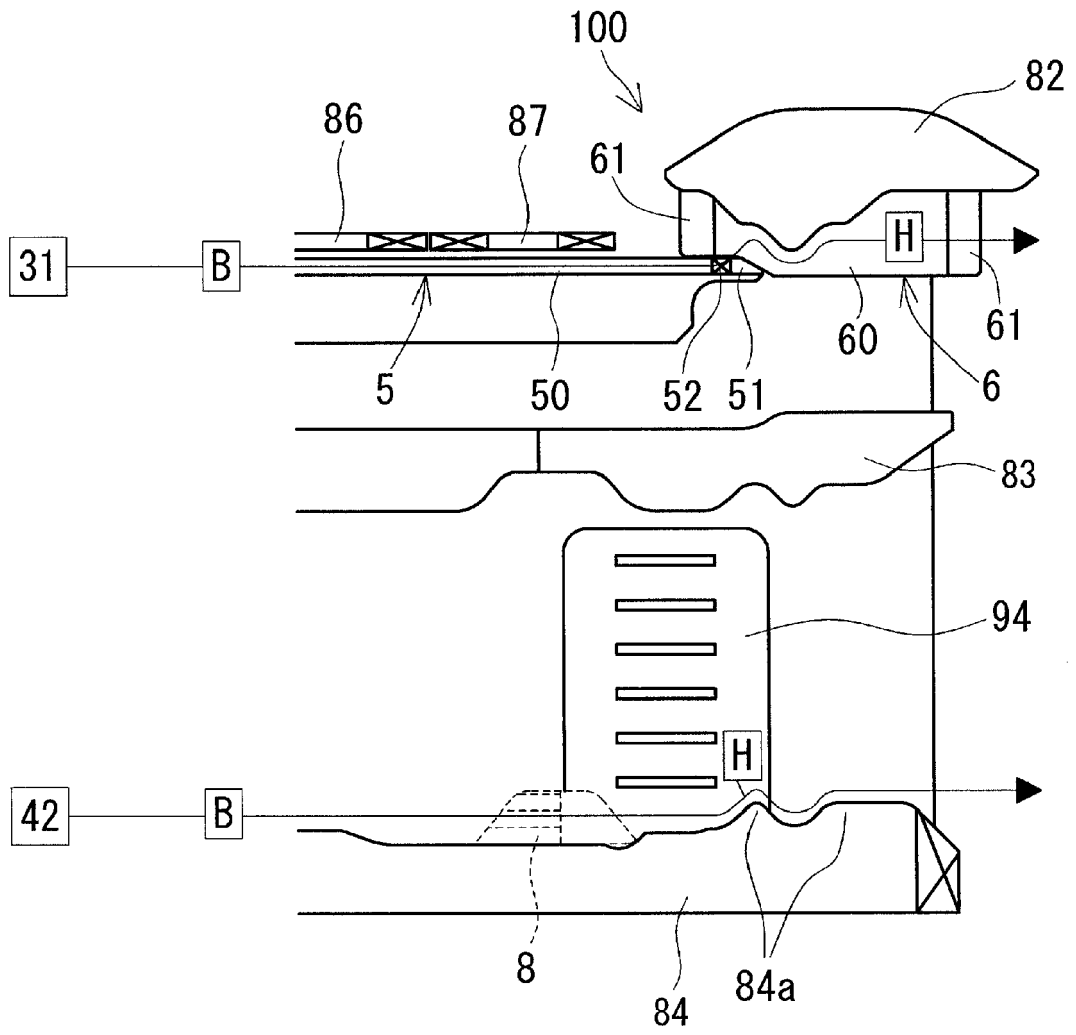

Fig. 5

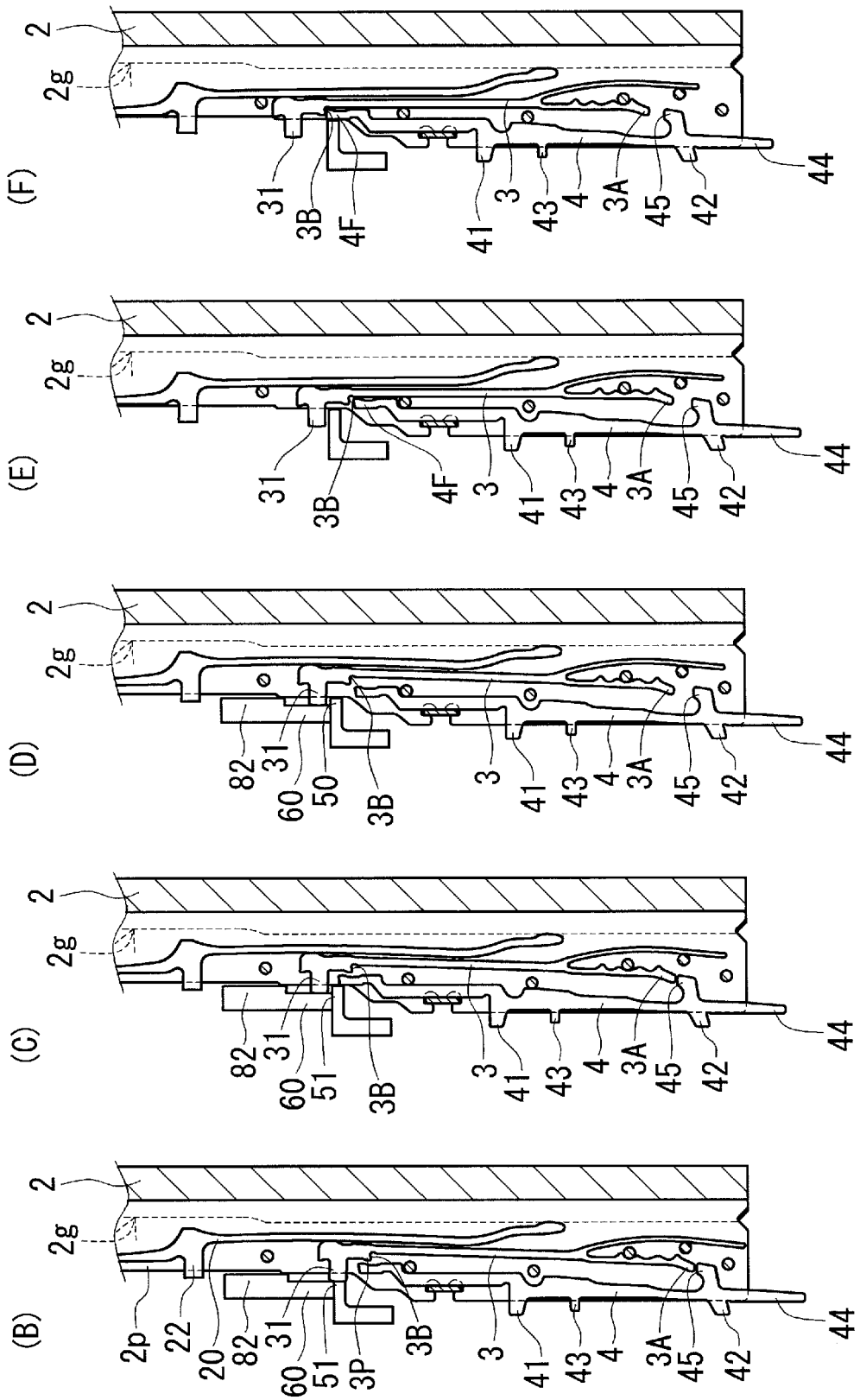

Fig. 6

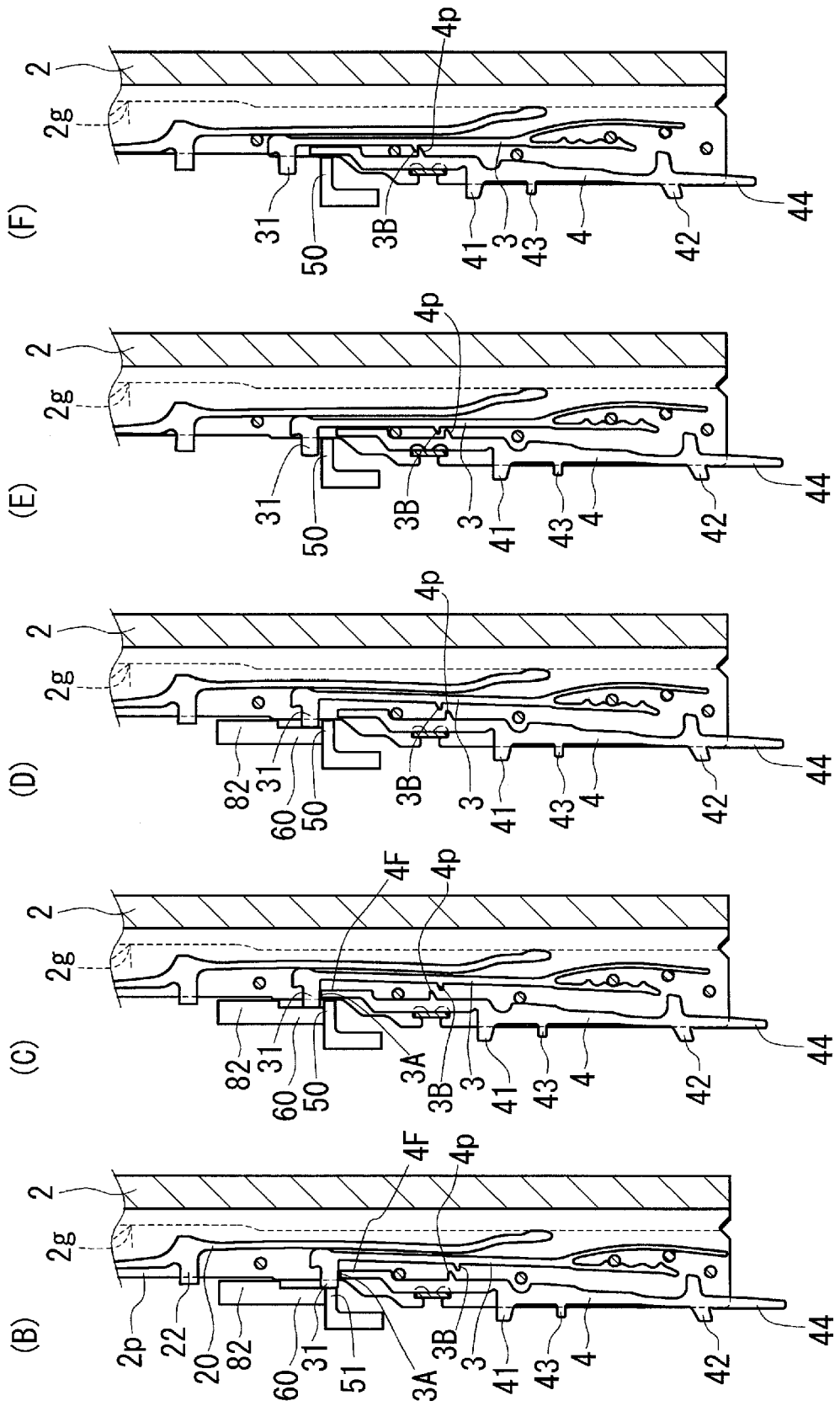

Fig. 7

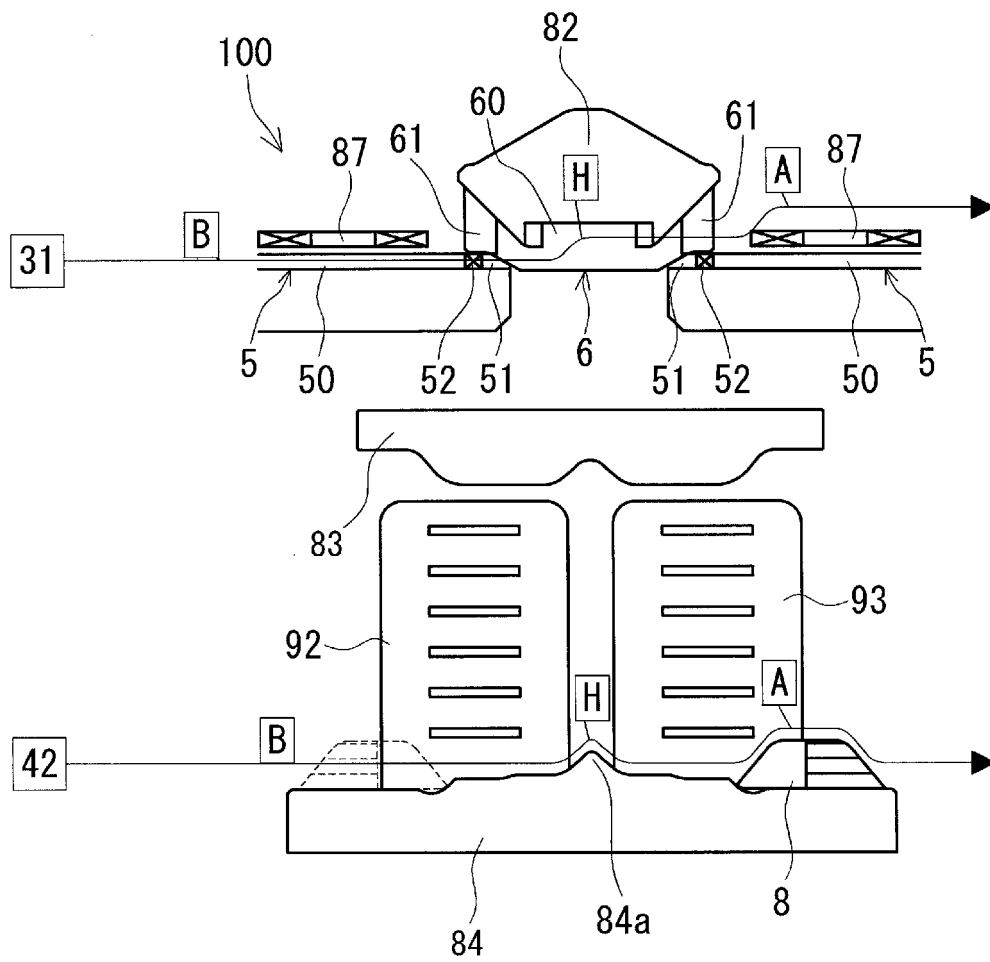

Fig. 8

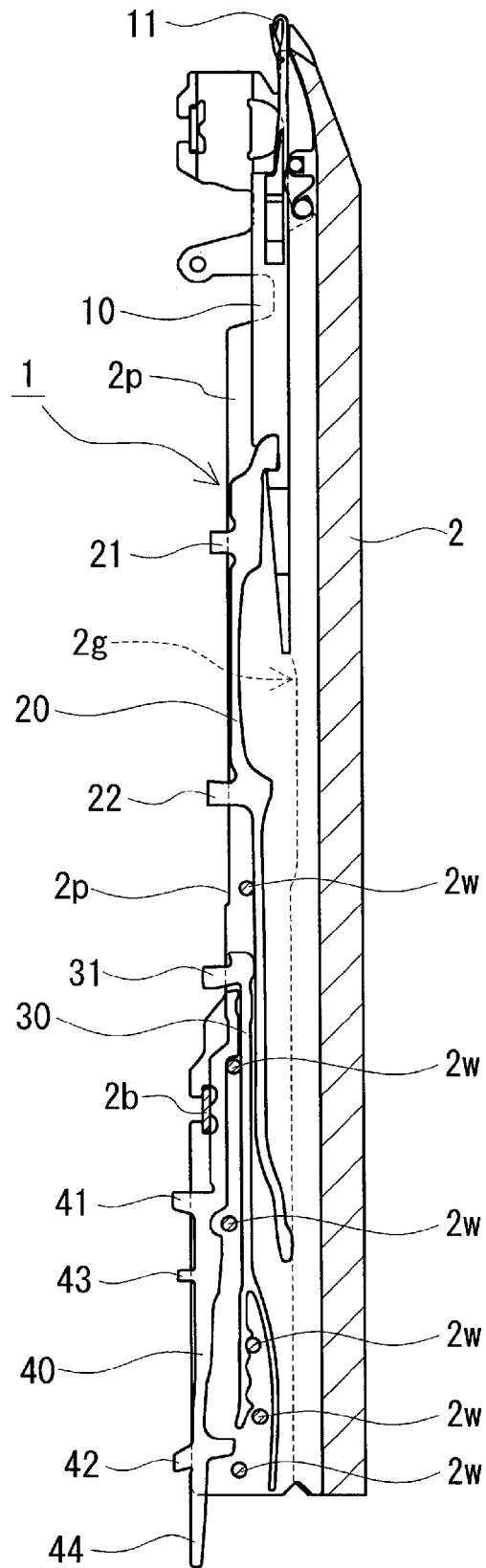
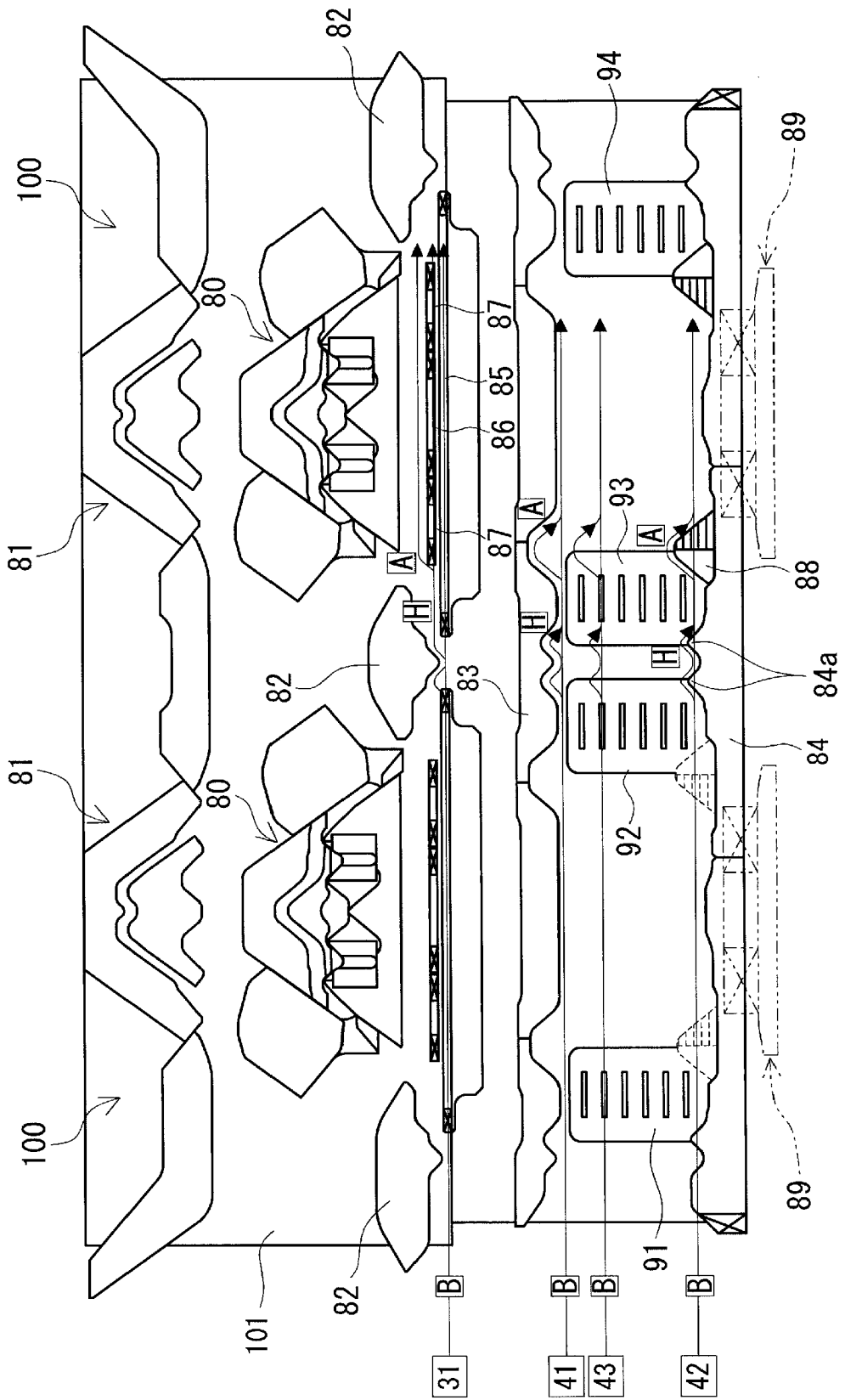

Fig. 9





EUROPEAN SEARCH REPORT

Application Number
EP 20 16 7838

5

10

15

20

25

30

35

40

45

50

55

DOCUMENTS CONSIDERED TO BE RELEVANT			
Category	Citation of document with indication, where appropriate, of relevant passages	Relevant to claim	CLASSIFICATION OF THE APPLICATION (IPC)
Y,D	EP 1 975 295 A1 (SHIMA SEIKI MFG [JP]) 1 October 2008 (2008-10-01) * paragraphs [0003], [0005], [0007], [0013], [0018], [0023], [0028], [0029], [0030], [0031], [0035]; claim 1; figures 1-5 *	1-3	INV. D04B15/68 D04B15/32 D04B15/70
Y	JP H06 200455 A (SHIMA SEIKI MFG) 19 July 1994 (1994-07-19) * paragraph [0033]; figures 1-4 *	1-3	
			TECHNICAL FIELDS SEARCHED (IPC)
			D04B
The present search report has been drawn up for all claims			
Place of search Munich		Date of completion of the search 11 August 2020	Examiner Messai, Sonia
<p>CATEGORY OF CITED DOCUMENTS</p> <p>X : particularly relevant if taken alone Y : particularly relevant if combined with another document of the same category A : technological background O : non-written disclosure P : intermediate document</p> <p>T : theory or principle underlying the invention E : earlier patent document, but published on, or after the filing date D : document cited in the application L : document cited for other reasons & : member of the same patent family, corresponding document</p>			

1
EPO FORM 1503 03.82 (P04C01)

ANNEX TO THE EUROPEAN SEARCH REPORT
ON EUROPEAN PATENT APPLICATION NO.

EP 20 16 7838

5 This annex lists the patent family members relating to the patent documents cited in the above-mentioned European search report.
The members are as contained in the European Patent Office EDP file on
The European Patent Office is in no way liable for these particulars which are merely given for the purpose of information.

11-08-2020

Patent document cited in search report	Publication date	Patent family member(s)	Publication date
EP 1975295 A1	01-10-2008	CN 101351587 A	21-01-2009
		EP 1975295 A1	01-10-2008
		JP 5057996 B2	24-10-2012
		JP WO2007074944 A1	04-06-2009
		KR 20080081149 A	08-09-2008
		WO 2007074944 A1	05-07-2007

JP H06200455 A	19-07-1994	NONE	

REFERENCES CITED IN THE DESCRIPTION

This list of references cited by the applicant is for the reader's convenience only. It does not form part of the European patent document. Even though great care has been taken in compiling the references, errors or omissions cannot be excluded and the EPO disclaims all liability in this regard.

Patent documents cited in the description

- WO 2007074944 A [0013]
- JP 3459514 B [0061]