



US00D344062S

United States Patent [19]

[11] Patent Number: Des. 344,062

Kashiwara et al.

[45] Date of Patent: ** Feb. 8, 1994

[54] AUXILIARY ELEMENT FOR IGNITION PLUGS FOR INTERNAL COMBUSTION ENGINES FOR AUTOMOBILES

[76] Inventors: **Ryohei Kashiwara**, Raitsu Ootori 106, 456-1, Ootori-kitamachi 8-cho, Sakai-shi Osaka-fu; **Hideaki Kashiwara**, 3-B-611, 151-30, Mukojima Ninomarucho, Fushimi-ku, Kyoto-shi; **Hidehiko Noguchi**, 7-14, Taiho 3-chome, Kanancho, Minami-kawchi-gun, Osaka-fu; **Takeaki Kashiwara**, 3-37-411, Nagayoshidedo 3-chome, Hirano-ku, Osaka-shi, all of Japan

[**] Term: 14 Years

[21] Appl. No.: 915,960

[22] Filed: Jul. 21, 1992

[30] Foreign Application Priority Data

Jan. 21, 1992 [JP] Japan 4-1380
[52] U.S. Cl. D13/127; D15/5
[58] Field of Search 123/26, 169, 32, 32 K, 123/191; 313/139, 11.5, 141, 142, 93; D15/1-5; D13/127

[56] References Cited

U.S. PATENT DOCUMENTS

D. 180,302	5/1957	Thomas	D13/127
D. 238,678	2/1976	Hornsby	D13/127
1,224,296	5/1917	Gibson	.	
1,243,205	10/1917	Norman	.	
1,298,368	3/1919	Metzinger	.	
1,360,294	11/1920	Hill	313/139
1,371,488	3/1921	Jacobson	.	
1,644,633	10/1927	Buckingham	123/169
1,659,037	2/1928	MacDonald	.	
1,943,674	1/1934	Woods-Humphrey	123/169
1,963,801	6/1934	O'Marra	123/169
2,071,572	2/1937	Rabazzana et al.	123/169
2,096,199	10/1937	Rabazzana	123/169
2,129,003	9/1938	Grant	123/169
2,208,030	7/1940	Holmes	123/169
2,208,667	7/1940	Devine	123/169

(List continued on next page.)

FOREIGN PATENT DOCUMENTS

0167687 3/1986 European Pat. Off. .
625568 6/1975 France .
2479588 10/1981 France .
53-54774 10/1976 Japan .
53-87331 12/1976 Japan .
52-1243 1/1977 Japan .

(List continued on next page.)

Primary Examiner—A. Hugo Word
Assistant Examiner—R. Seifert
Attorney, Agent, or Firm—Fisher, Christen & Sabol

[57] CLAIM

The ornamental design for an auxiliary element for ignition plugs for internal combustion engines for automobiles, as shown and described.

DESCRIPTION

FIG. 1 is a perspective view of the auxiliary element for ignition plugs for internal combustion engines for automobiles of the invention;
FIG. 2 is a left side plane view of the auxiliary element for ignition plugs for internal combustion engines for automobiles of the invention;
FIG. 3 is a top plane view of the auxiliary element for ignition plugs for internal combustion engines for automobiles of the invention;
FIG. 4 is a bottom plane view of the auxiliary element for ignition plugs for internal combustion engines for automobiles of the invention;
FIG. 5 is a rear plane view of the auxiliary element for ignition plugs for internal combustion engines for automobiles of the invention;
FIG. 6 is a front plane view of the auxiliary element for ignition plugs for internal combustion engines for automobiles of the invention;
FIG. 7 is a left side cross-sectional view of the auxiliary element of the invention along lines 7—7 of FIG. 4;
FIG. 8 is a front cross-sectional view of the auxiliary element of the invention along lines 8—8 of FIG. 4; and,
FIG. 9 is a perspective view of the auxiliary element of the invention, the broken line showing of an ignition plug is for illustrative purposes only.

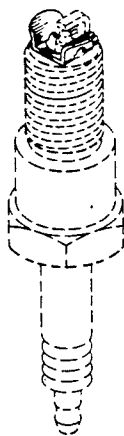

U.S. PATENT DOCUMENTS

2,217,825	10/1940	Twining et al.	123/169
2,246,948	6/1941	McCarty et al.	123/169
2,305,208	12/1942	Trammel et al.	123/191
2,336,569	12/1943	Rabazzana	123/169
2,368,889	2/1945	Setterblade	123/169
2,372,867	4/1945	Tognola	123/169
2,391,459	12/1945	Hensel	123/169
2,616,407	11/1952	Thomas	123/169
2,944,178	7/1960	Schaub	313/141
3,229,139	1/1966	Watson	313/11.5
3,238,447	3/1966	Bychinsky	324/15
3,313,972	4/1967	Beesch	313/130
3,515,925	6/1970	Rickhey	313/139
3,710,772	1/1973	Warner	123/169
3,908,625	9/1975	Romy	123/32
3,921,020	11/1975	Wax	313/123
3,970,885	7/1976	Kasima	313/141
4,023,058	5/1977	Lara et al.	313/139
4,028,576	6/1977	Wofsey	313/143
4,109,633	8/1978	Mitsudo et al.	123/169

4,123,998	11/1978	Heintzelman	123/32 K
4,164,912	8/1979	Beyler	123/26
4,336,477	6/1982	Yamada	313/142
4,401,915	8/1983	Kashiwara et al.	313/142
4,808,878	2/1989	Kashiwara et al.	313/141
4,851,732	7/1989	Kashiwara et al.	313/141
4,901,688	2/1990	Kashiwara et al.	123/169
4,983,877	1/1991	Kashiwara et al.	313/140
5,007,389	4/1991	Kashiwara et al.	123/169
5,090,373	2/1992	Kashiwara et al.	123/169

FOREIGN PATENT DOCUMENTS

53-25743	3/1978	Japan	.
54-91644	7/1979	Japan	.
54-117948	9/1979	Japan	.
61-112726	5/1986	Japan	.
61-30394	7/1986	Japan	.
62-11471	3/1987	Japan	.
1-176690	7/1989	Japan	.
2-142080	5/1990	Japan	.
2-144873	6/1990	Japan	.
187501	10/1922	United Kingdom	.

FIG. 1

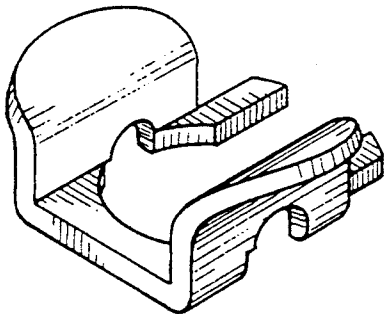

FIG. 2

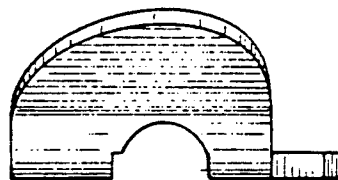

FIG. 3

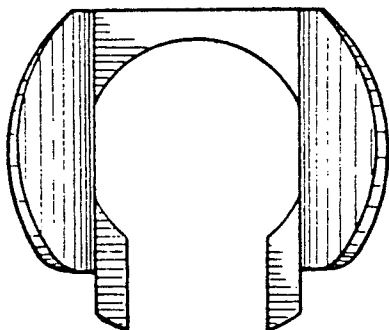

FIG. 4

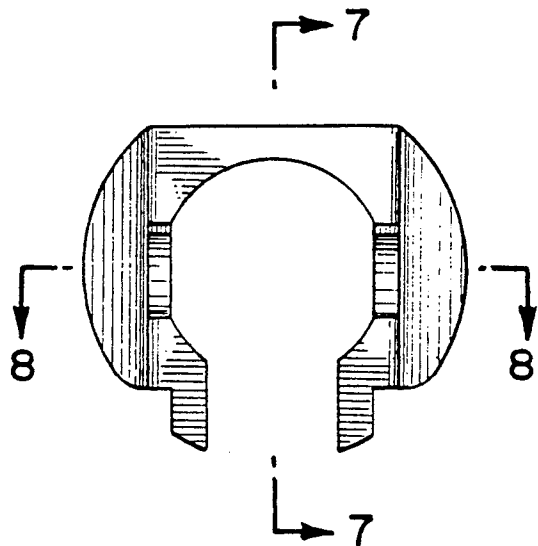

FIG. 5



FIG. 6

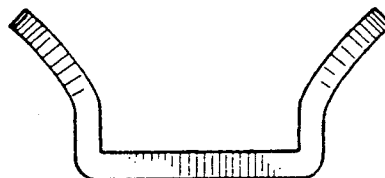

FIG. 7

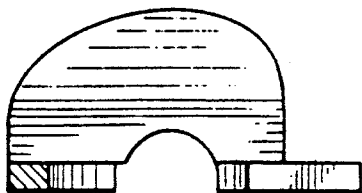

FIG. 8

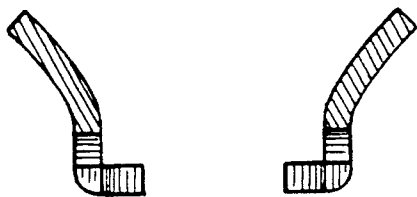

FIG. 9

