



(19) **United States**

(12) **Patent Application Publication**
Berman et al.

(10) **Pub. No.: US 2006/0128454 A1**

(43) **Pub. Date: Jun. 15, 2006**

(54) **APPARATUS AND METHOD FOR DETERMINING GAMING PAYOUTS USING PARTIAL GAME CRITERIA**

Publication Classification

(75) Inventors: **Bradley Berman**, Minnetonka, MN (US); **Jacob Lamb**, Plymouth, MN (US)

(51) **Int. Cl.**
A63F 9/24 (2006.01)
(52) **U.S. Cl.** **463/13**

Correspondence Address:
Hollingsworth & Funk, LLC
Suite 125
8009 34th Avenue South
Minneapolis, MN 55425 (US)

(57) **ABSTRACT**

(73) Assignee: **King Show Games LLC**

(21) Appl. No.: **11/134,975**

(22) Filed: **May 23, 2005**

Related U.S. Application Data

(60) Provisional application No. 60/634,877, filed on Dec. 10, 2004.

Apparatuses and methods for facilitating play in gaming activities and providing manipulation of payout awards based on partial game criteria. A bonus value such as a multiplier is awarded based on a partial result of the gaming activity, if the partial result corresponds to any predetermined partial result(s). The gaming activity is completed to provide a complete result, and a payout is determined for the complete result. If the partial result corresponds to any of the predetermined partial results, the payout for the complete result is adjusted using the awarded bonus value to provide a final payout.

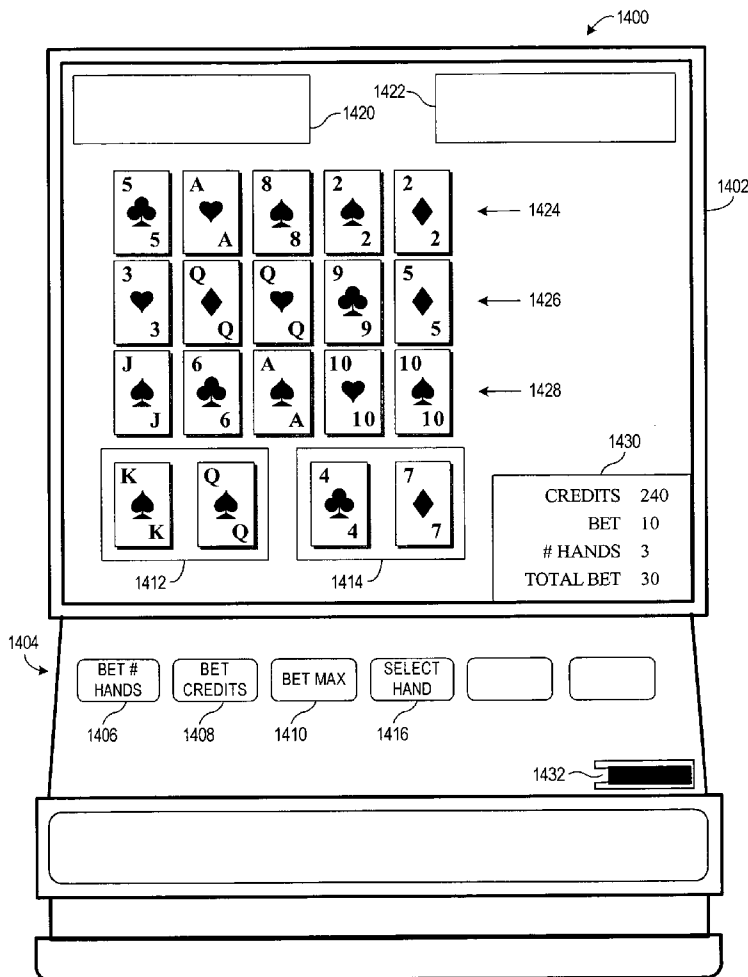

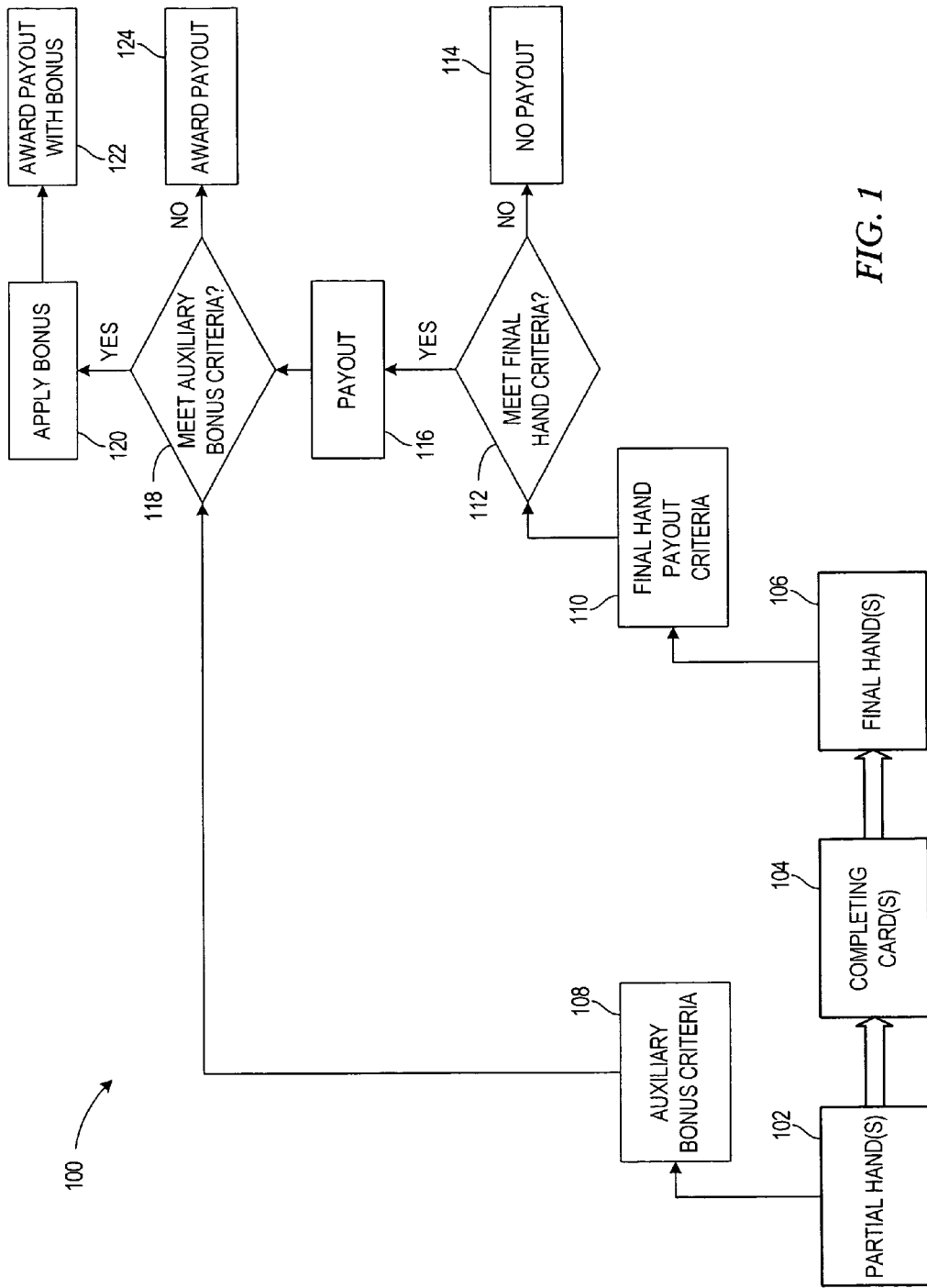

FIG. 1

200

202

204

STARTING HAND TYPE	MULTIPLIER
2 RED ACES	10
SUITED ACE/KING	5
SUITED ACE/QUEEN	4
SUITED ACE/JACK	3
SUITED KING/QUEEN	2
SUITED KING/JACK	2
SUITED QUEEN/JACK	2
PAIR OF ACES	7
PAIR OF KINGS, QUEENS, OR JACKS	4

FIG. 2A

210

202

212

STARTING HAND TYPE	PAY
2 RED ACES	3
SUITED ACE/KING	1
SUITED ACE/QUEEN	1
SUITED ACE/JACK	1
SUITED KING/QUEEN	1
SUITED KING/JACK	1
SUITED QUEEN/JACK	1
PAIR OF ACES	2
PAIR OF KINGS, QUEENS, OR JACKS	1

FIG. 2B

220

202

212

204

STARTING HAND TYPE	PAY	MULTIPLIER
2 RED ACES	3	10
SUITED ACE/KING	1	5
SUITED ACE/QUEEN	1	4
SUITED ACE/JACK	1	3
SUITED KING/QUEEN	1	2
SUITED KING/JACK	1	2
SUITED QUEEN/JACK	1	2
PAIR OF ACES	2	7
PAIR OF KINGS, QUEENS, OR JACKS	1	4

FIG. 2C

300

202	212	204	304	306
STARTING HAND TYPE	PAY	MULT	FINAL HAND TYPE	PAY
2 RED A'S	1	6	ROYAL FLUSH ON THE BOARD	500
SUITED A/K	0	3	ROYAL FLUSH	100
SUITED A/Q	0	3	STRAIGHT FLUSH	50
SUITED A/J	0	2	FOUR A'S	25
SUITED K/Q	0	2	FOUR 2'S THROUGH K'S	10
SUITED K/J	0	2	FULL HOUSE	5
SUITED Q/J	0	2	FLUSH	4
PAIR OF A'S	1	5	STRAIGHT	3
PAIR OF K'S, Q'S, OR J'S	1	2	THREE OF A KIND	2
			TWO PAIRS	1

220

308

310

BET=1 312

FIG. 3A

320

202	212	204	304	306
STARTING HAND TYPE	PAY	MULT	FINAL HAND TYPE	PAY
2 RED A'S	5	6	ROYAL FLUSH ON THE BOARD	2500
SUITED A/K	0	3	ROYAL FLUSH	500
SUITED A/Q	0	3	STRAIGHT FLUSH	250
SUITED A/J	0	2	FOUR A'S	125
SUITED K/Q	0	2	FOUR 2'S THROUGH K'S	50
SUITED K/J	0	2	FULL HOUSE	25
SUITED Q/J	0	2	FLUSH	20
PAIR OF A'S	5	5	STRAIGHT	15
PAIR OF K'S, Q'S, OR J'S	5	2	THREE OF A KIND	10
			TWO PAIRS	5

220

308

310

BET=5 312

FIG. 3B

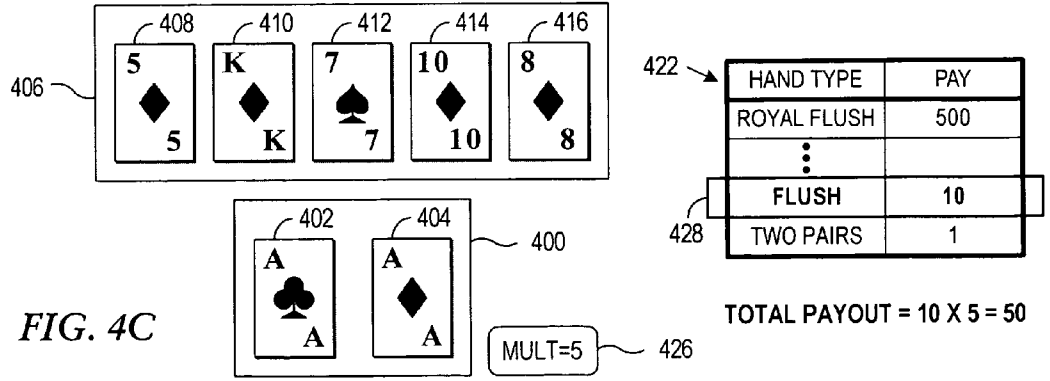
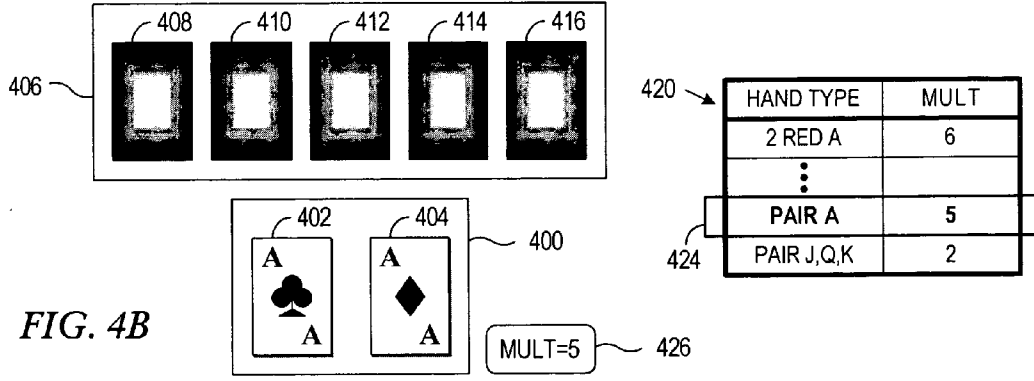
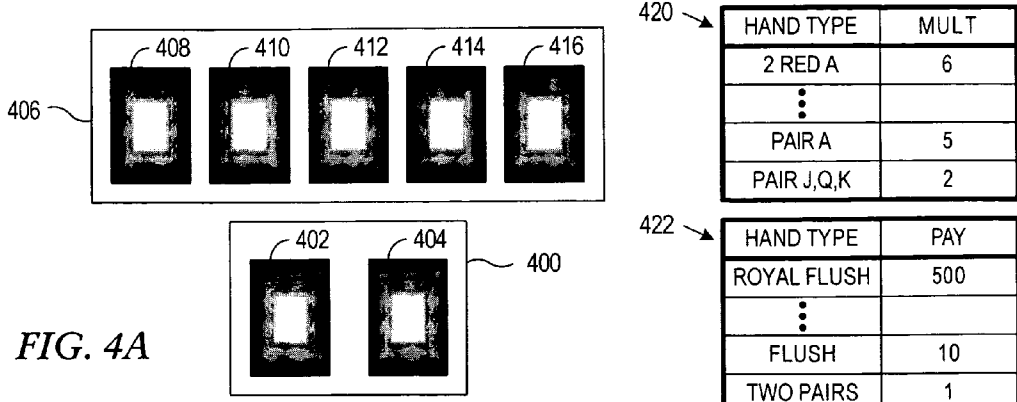

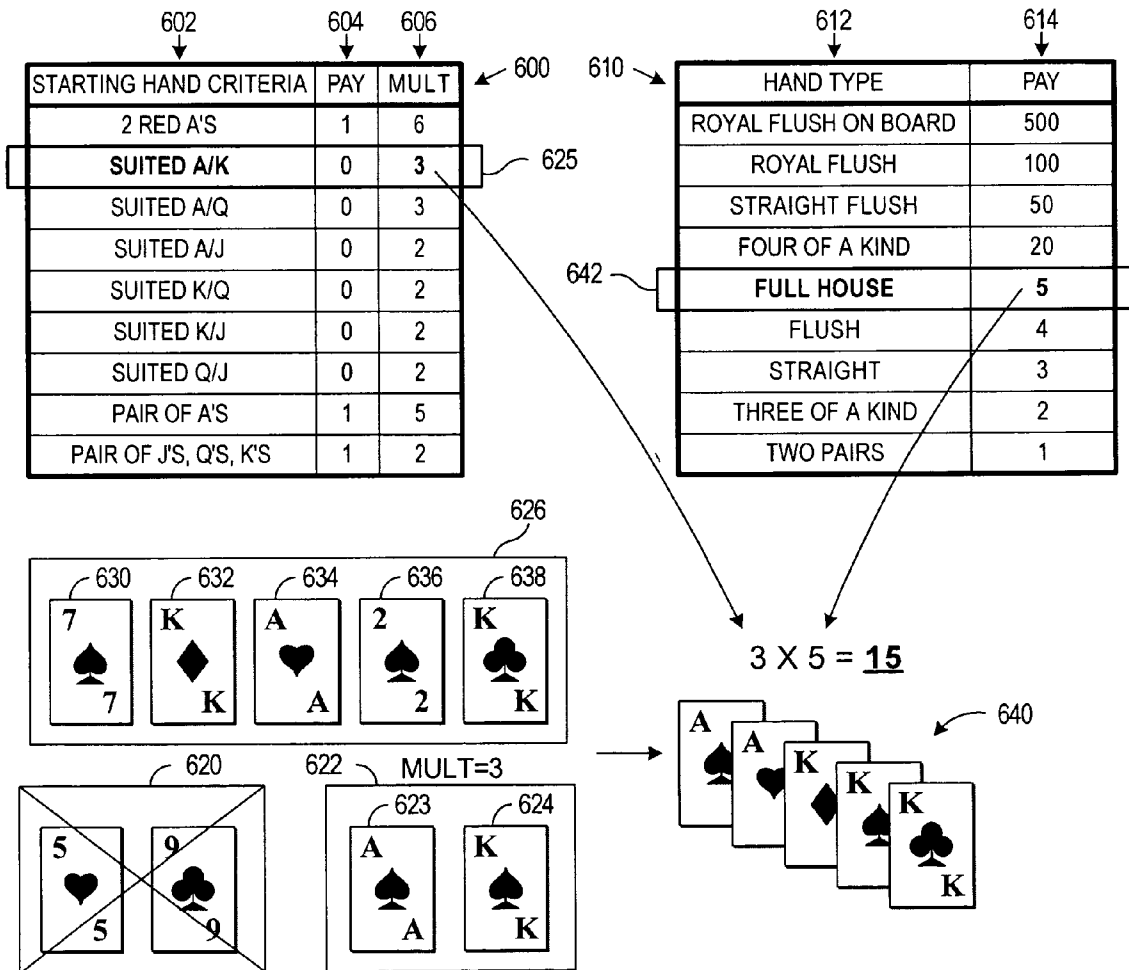
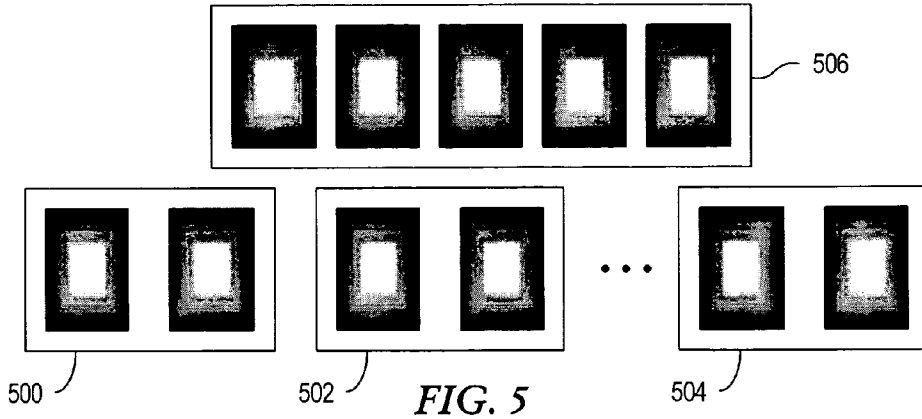

FIG. 6

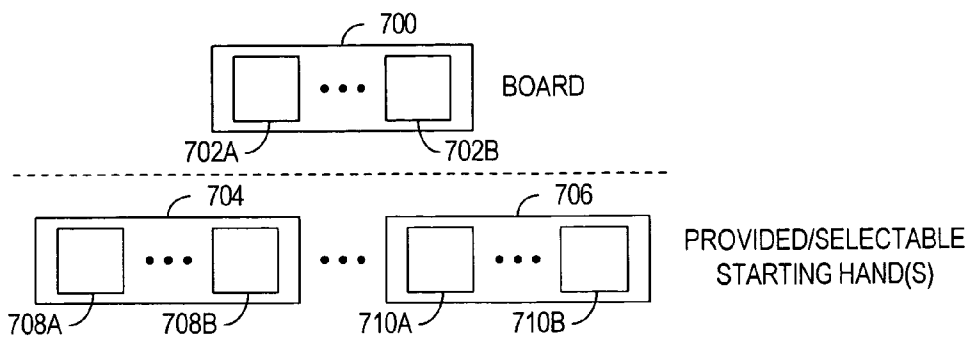

FIG. 7

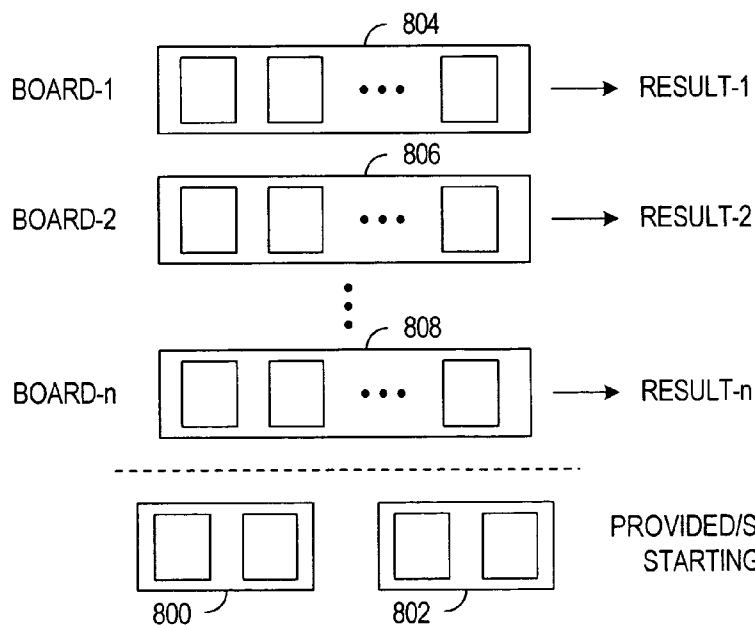

FIG. 8

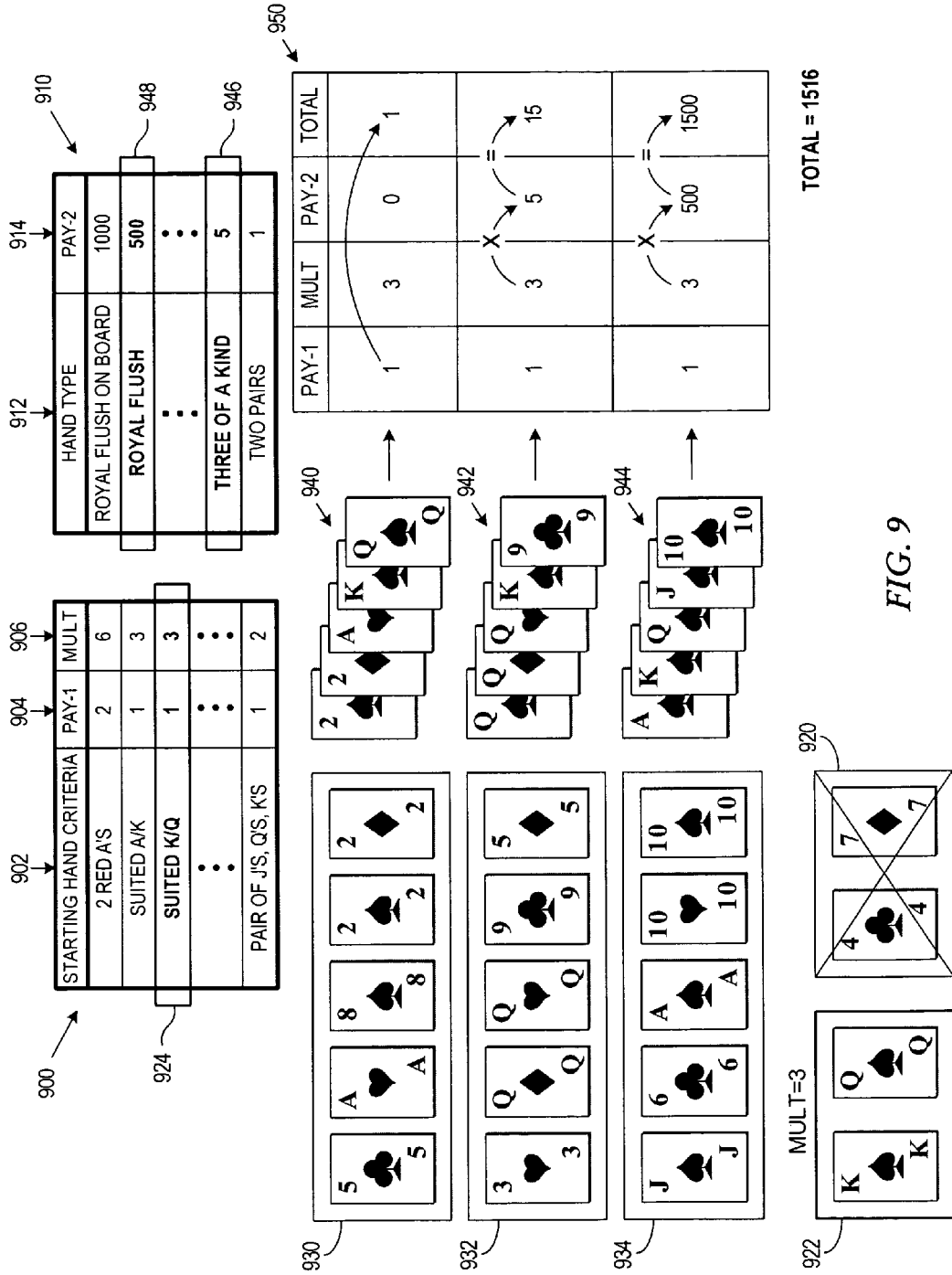

FIG. 9

1000	1002	1004	1006	1008	1010	1012	1014
STARTING HAND TYPE	PAY(1 _S)	PAY(10 _S)	MULT	RESULTING HAND TYPE	PAY(1 _R)	PAY(10 _R)	
2 RED A'S	1	10	6	ROYAL FLUSH ON BOARD	500	5000	
SUITED A/K	0	0	3	ROYAL FLUSH	100	1000	
SUITED A/Q	0	0	3	STRAIGHT FLUSH	50	500	
SUITED A/J	0	0	2	FOUR A'S	25	250	
SUITED K/Q	0	0	2	FOUR 2'S THROUGH K'S	10	100	
SUITED K/J	0	0	2	FULL HOUSE	5	50	
SUITED Q/J	0	0	2	FLUSH	4	40	
PAIR OF A'S	1	10	5	STRAIGHT	3	30	
PAIR OF K'S, Q'S, OR J'S	1	10	2	THREE OF A KIND	2	20	
				TWO PAIRS	1	10	

EXAMPLE-1

BET	HAND BET	TOTAL BET
1	1	1

STARTING HAND	PAY(1 _S)	MULT	RESULTING HAND	PAY(1 _R)	TOTAL PAYOUT
4H,6D	0	0	2 PAIRS	1	1

EXAMPLE-2

BET	HAND BET	TOTAL BET
1	3	3

STARTING HAND	PAY(1 _S)	MULT	RESULTING HAND	PAY(1 _R)	TOTAL PAYOUT
2 RED A'S	1	6	2 PAIRS	1	6
2 RED A'S	1	6	FLUSH	4	24
2 RED A'S	1	6	PAIR A'S	0	1

EXAMPLE-3

BET	HAND BET	TOTAL BET
10	3	30

STARTING HAND	PAY(10 _S)	MULT	RESULTING HAND	PAY(10 _R)	TOTAL PAYOUT
SUITED A/K	0	3	2 PAIRS	10	30
SUITED A/K	0	3	4 A'S	250	750
SUITED A/K	0	3	PAIR A'S	0	0

FIG. 10

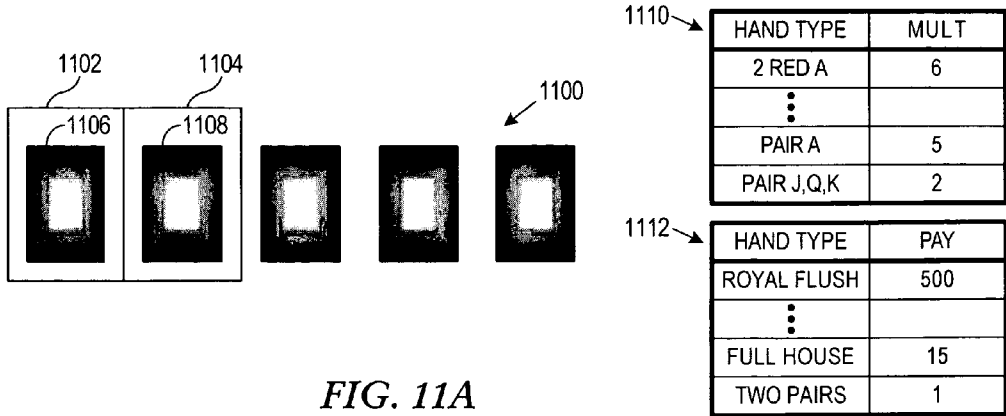

FIG. 11A

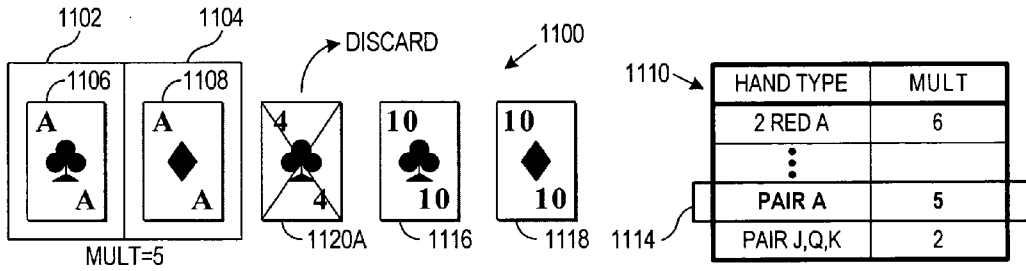

FIG. 11B

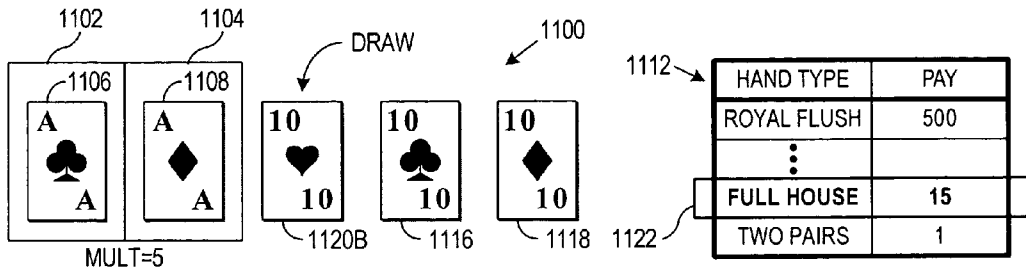

FIG. 11C

TOTAL PAYOUT = 15 X 5 = 75

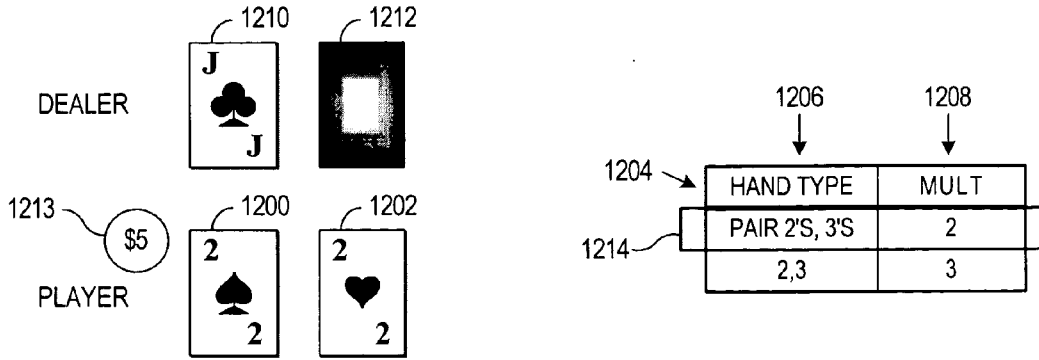

FIG. 12A

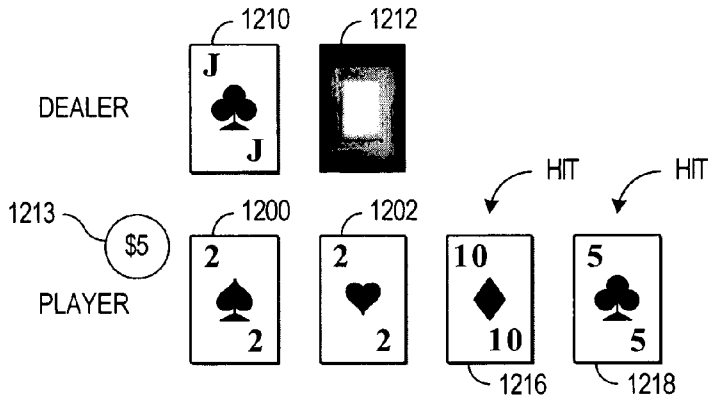

FIG. 12B

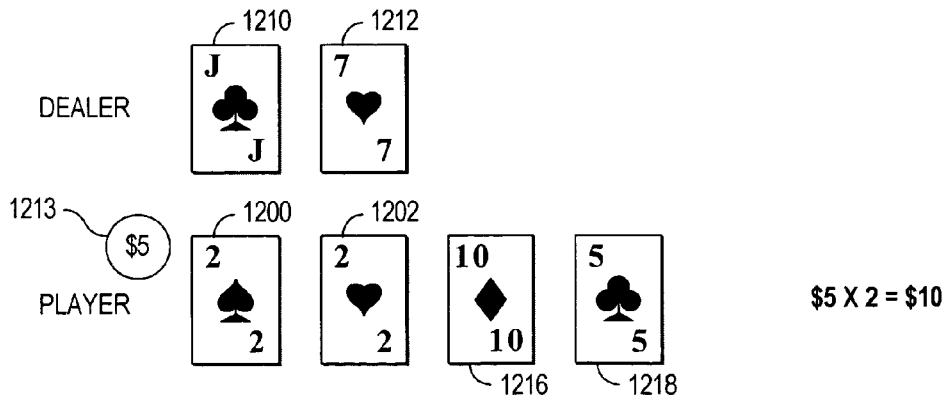

FIG. 12C

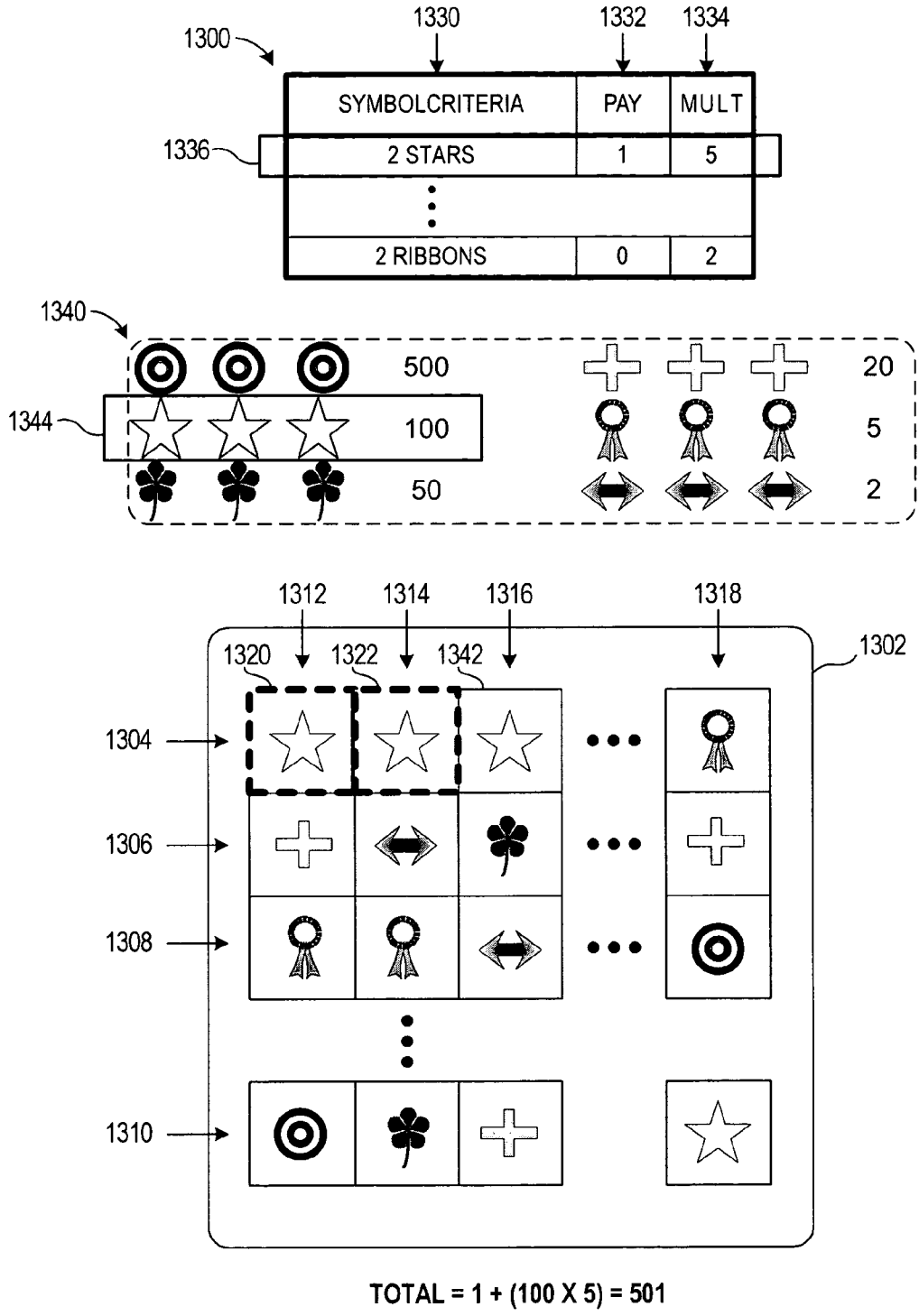

FIG. 13

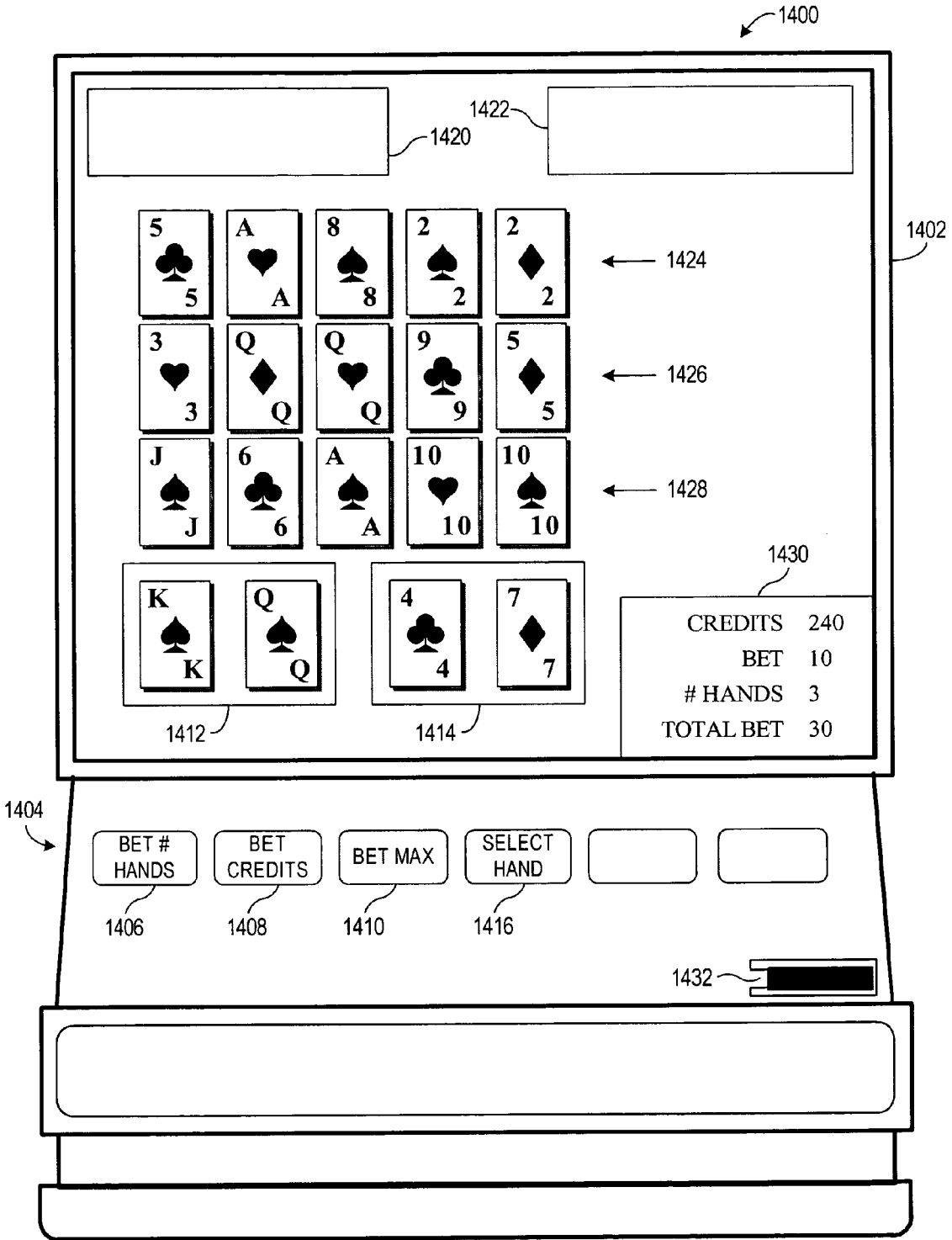

FIG. 14

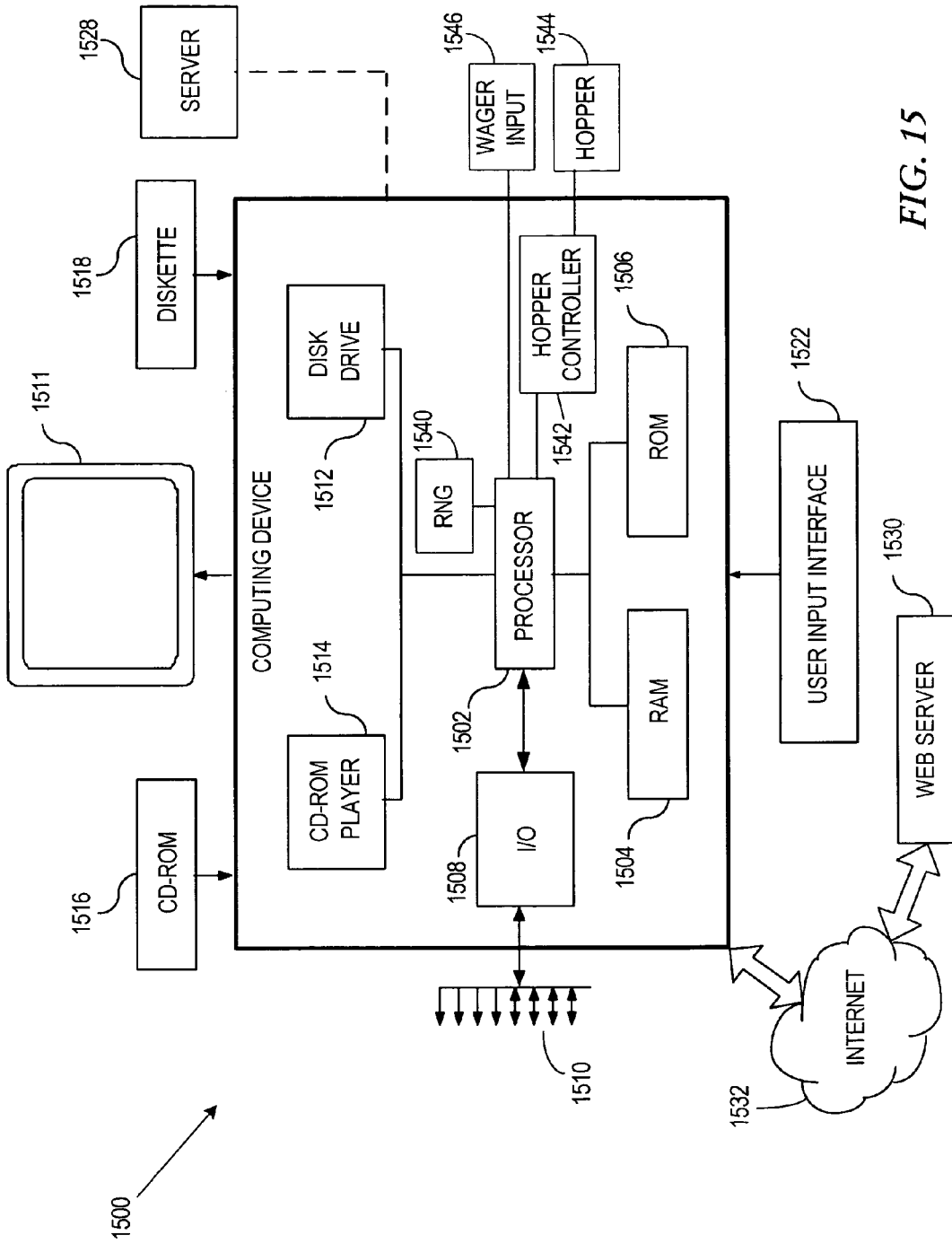

FIG. 15

1625

STARTING HAND TYPE	PAY-1	PAY-2	PAY-3	MULT	FINAL HAND TYPE	PAY-1	PAY-2	PAY-3
2 RED A'S	1	2	3	6	ROYAL FLUSH	100	200	300
SUITED A/K	0	0	0	3	STRAIGHT FLUSH	50	100	150
SUITED A/Q	0	0	0	3	FOUR OF A KIND	25	50	75
SUITED A/J	0	0	0	2	FULL HOUSE	5	10	15
SUITED K/Q	0	0	0	2	FLUSH	4	8	12
SUITED K/J	0	0	0	2	STRAIGHT	3	6	9
PAIR OF A'S	1	2	3	5	THREE OF A KIND	2	4	6
PAIR OF K'S, Q'S, OR J'S	1	2	3	2	TWO PAIRS	1	2	3

1630

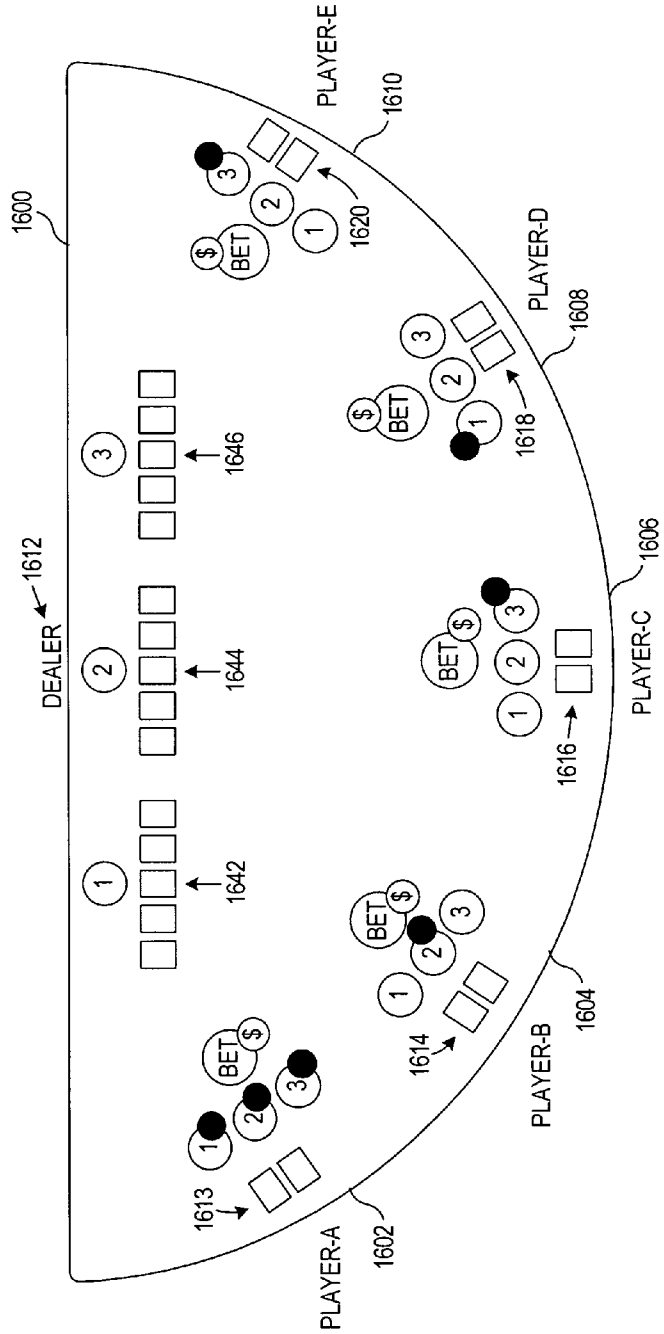

FIG. 16

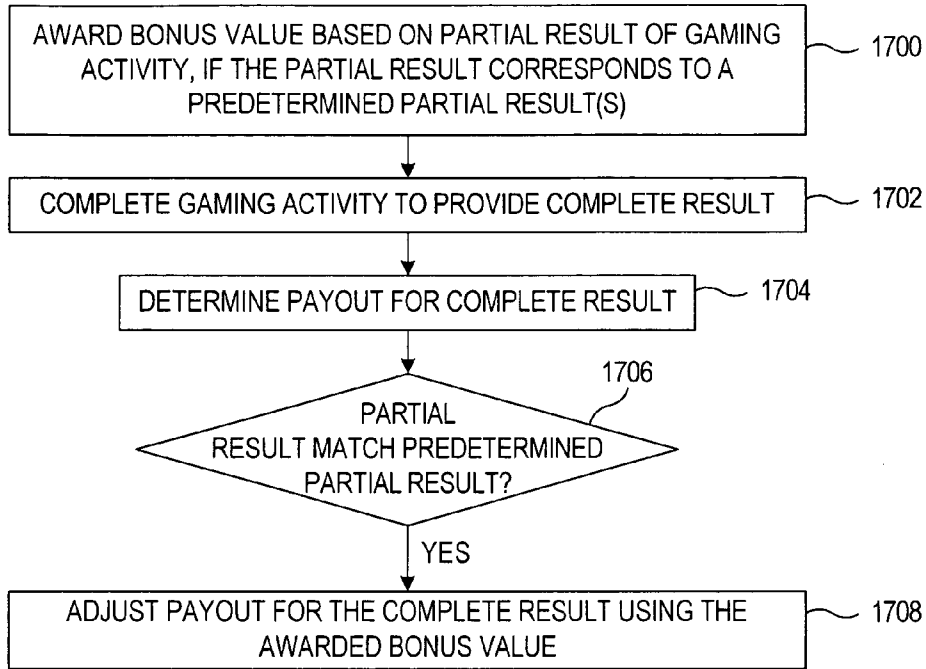

FIG. 17

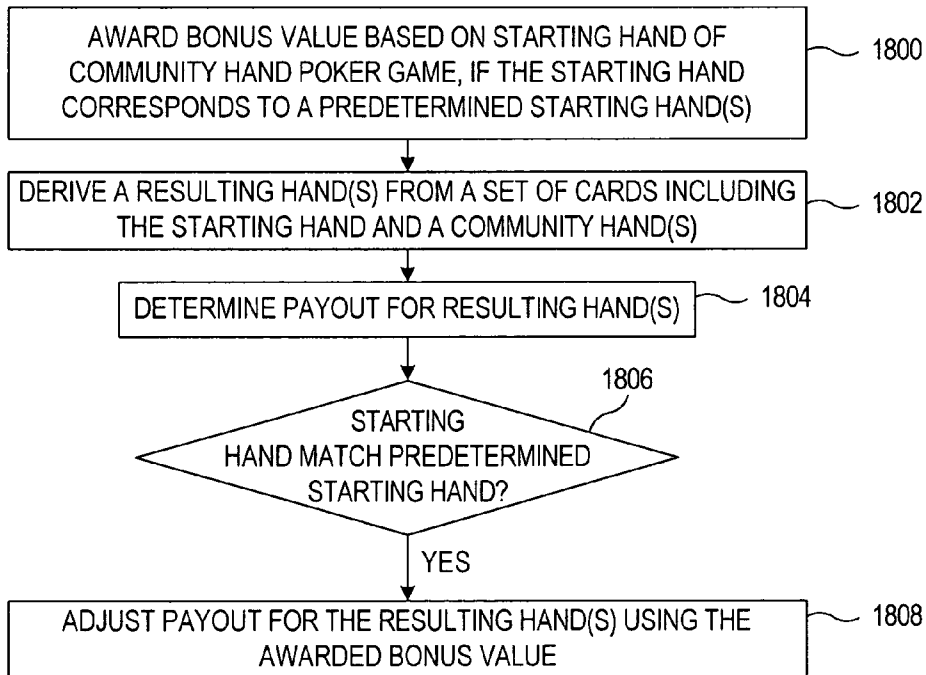

FIG. 18

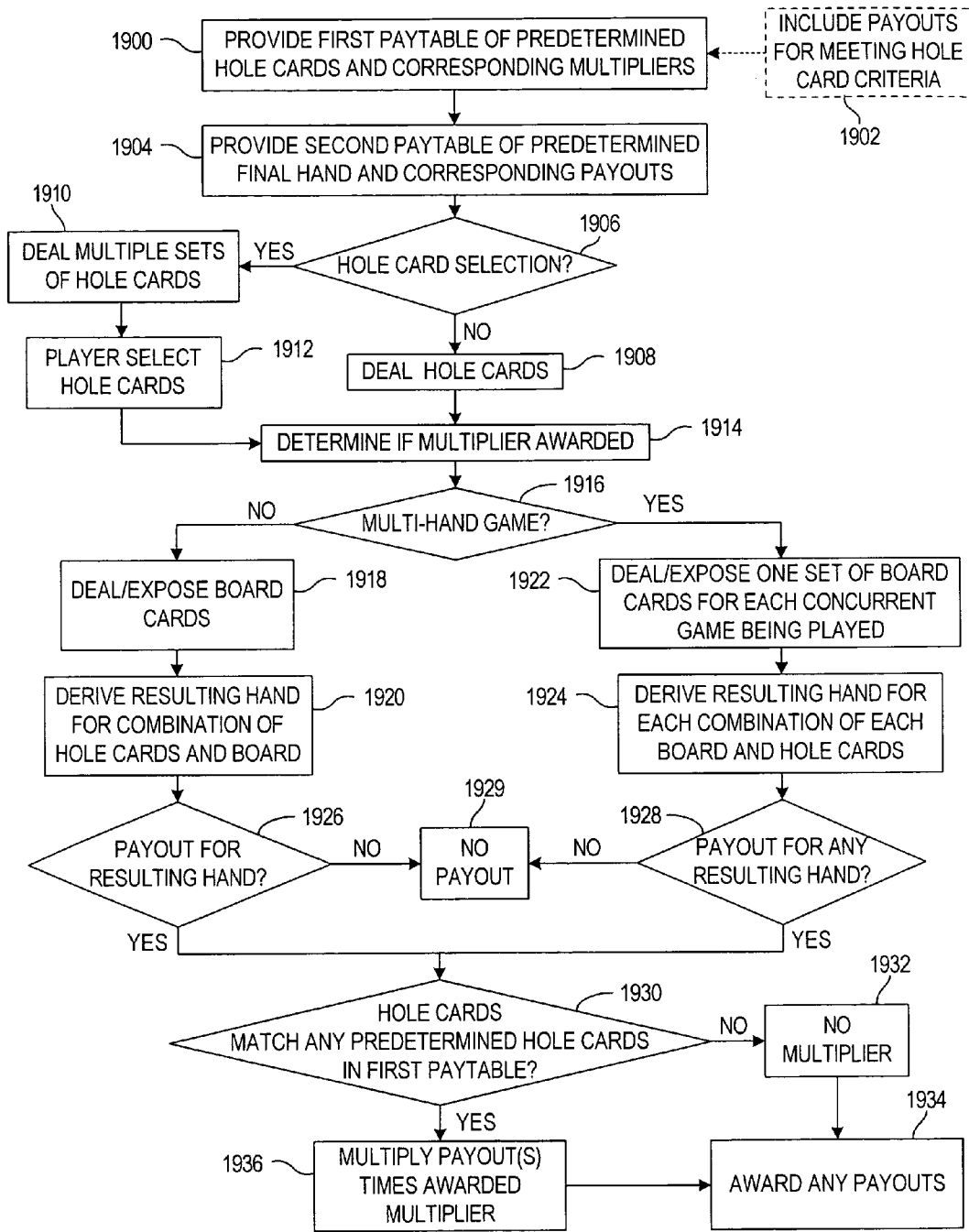

FIG. 19

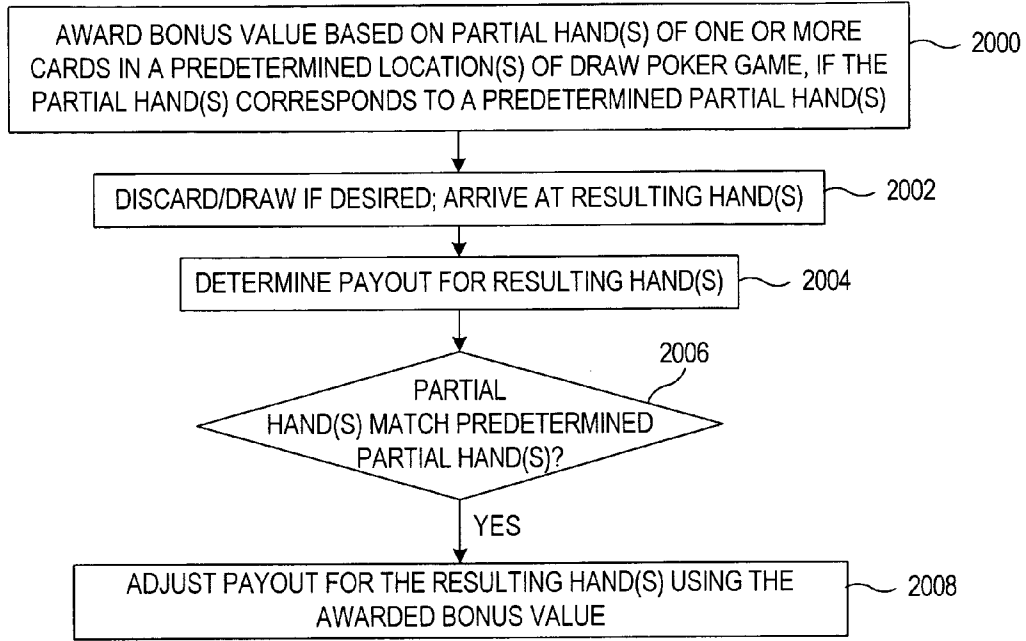

FIG. 20

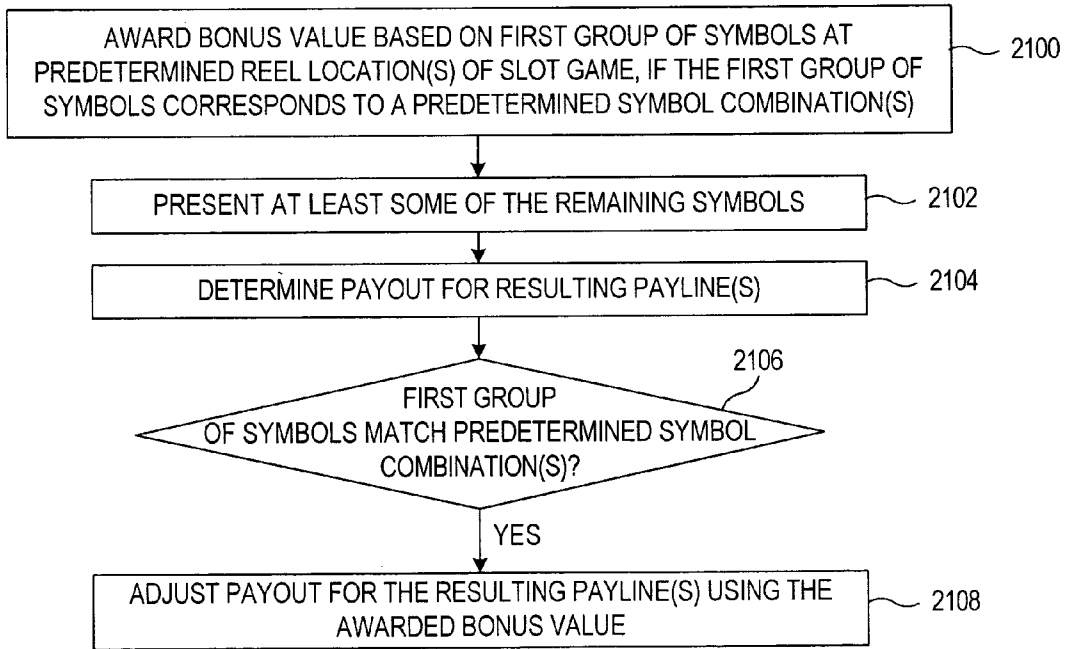

FIG. 21

APPARATUS AND METHOD FOR DETERMINING GAMING PAYOUTS USING PARTIAL GAME CRITERIA

[0001] This application claims the benefit of U.S. Provisional Application No. 60/634,877 filed Dec. 10, 2004, the content of which is incorporated herein by reference in its entirety.

FIELD OF THE INVENTION

[0002] This invention relates in general to games, and more particularly to apparatuses and methods for facilitating play in gaming activities and providing manipulation of payout awards based on partial game criteria.

BACKGROUND OF THE INVENTION

[0003] Card games such as poker have long been enjoyed as a means of entertainment. The popularity of casino gambling with wagering continues to increase, as does recreational gambling such as non-wagering computer game gambling. In some traditional cardroom poker games, players gather to compete against each other, and place bets that their poker hand will have a higher poker rank than the other players' hands. The highest poker rank in each played hand is the winner of the hand. If bets were made by the players, the winner collects the bets made by the losing players for that hand.

[0004] It may be the case that players would rather place their bets against the "house," rather than against each other. Some players would prefer not to be direct adversaries of other players for various reasons, including a lack of player-to-player poker skills, limiting controversy, etc. Other games such as video poker games may not involve other "actual" participants, although other "virtual" participants may be involved. For these and other reasons, it may be desirable to provide an avenue for participants to play against the house, at least with respect to the exchange of money.

[0005] However, when played in their conventional manner, some poker games are not particularly well suited for playing against the house. This may be due to various reasons. For example, the particular manner in which the game is traditionally played may present inherent difficulties in changing the game to a video version or house-banked version. Further, because other players may not be involved, some of the game excitement may be lost when playing against a dealer or participating in a video version. To address the different interests of different gaming participants, and to provide casinos and other gaming hosts with attractive alternatives, new slot machines games, poker games, and other gaming activities are continually sought after.

[0006] For example, "traditional" Hold'em poker implemented in a video poker format arguably does not have the allure of other poker counterpart games. This may be due to any number of reasons. One reason may be that until recently, Hold'em poker has not enjoyed the popularity of other forms of poker. However, due to the recent enormous increase in the popularity and exposure of Hold'em-type poker games played in table format, a potential demand is present for video alternatives.

[0007] Another drawback of traditional Hold'em poker when presented in video format is the lack of payout

variation. While player anticipation and excitement is present as to the final hand that may be presented, video presentations generally lack the intra-hand betting interaction and/or other play variations. Thus, other than the face value of cards (or other symbols/indicia) that leads to the final outcome, player anticipation and excitement at earlier stages of the hand/activity is generally limited or otherwise nonexistent.

[0008] The shortcomings of the prior art are also applicable to other gaming activities. Accordingly, there is a need in the gaming industry for a manner of introducing anticipation and excitement for players participating in gaming activities at earlier stages in the card hand or other gaming activity. A further need exists to provide casinos or other gaming providers with the means to attract and retain players at video and table versions of such gaming activities. The present invention fulfills these and other needs, and offers other advantages over prior art gaming approaches.

SUMMARY OF THE INVENTION

[0009] To overcome limitations in the prior art described above, and to overcome other limitations that will become apparent upon reading and understanding the present specification, the present invention discloses apparatuses and methods for facilitating play in gaming activities and providing manipulation of payout awards based on partial game criteria.

[0010] In accordance with one embodiment of the invention, a method is provided for facilitating play of a gaming activity. The method involves awarding a bonus value based on a partial result of the gaming activity, if the partial result corresponds to any predetermined partial result(s). The gaming activity is completed to provide a complete result, and a payout is determined for the complete result. If the partial result corresponds to any of the predetermined partial results, the payout for the complete result is adjusted using the awarded bonus value to provide a final payout.

[0011] According to more particular embodiments of such a method, awarding the bonus value includes awarding a value to be mathematically applied to the payout to arrive at the final payout. This may include, for example, awarding a multiplier value to be multiplied to the payout to arrive at the final payout. In one embodiment, the adjustment to the payout involves increasing the payout by a mathematical function of the bonus value such as, for example, increasing the payout proportionately using the bonus value, increasing the payout exponentially using the bonus value, etc. In one embodiment, any adjustment to the payout will not occur unless the partial result corresponds to at least one of the predetermined partial results. In another embodiment, if the partial result matches any of the predetermined partial results but no payout was awarded for the complete result, a fixed bonus payout identified by the predetermined partial result that corresponds to the partial result of the gaming activity may be provided. In yet another embodiment, if the partial result matches any of the predetermined partial results and if the payout available for the complete result is less than a fixed bonus payout identified by the predetermined partial result that corresponds to the partial result of the gaming activity, further comprising providing as the final payout the fixed bonus payout identified by the predetermined partial result that corresponds to the partial result.

[0012] In other particular embodiments of such a method, user selection of the partial result from a plurality of possible partial results is allowed. For example, in a Hold'em embodiment, a plurality of partial starting hands may be presented to the player, who in turn selects one or more to play.

[0013] In one particular embodiment, such a method according to the invention may be implemented in a poker game. The partial result of the poker game may include a first set of cards, and the predetermined partial result(s) may include predetermined set(s) of card(s). The poker game is completed to provide a complete result by deriving a resulting hand from a set of cards including the first set of cards and a second set of cards. A payout for the complete result may be determined by comparing the resulting hand to a payable to determine the payout, if any, that corresponds to the resulting hand. The payout is adjusted using the awarded bonus value if the first set of cards corresponds to any of the predetermined sets of cards. In a more particular embodiment, the first set of cards may include a two-card starting hand, and the second set of cards may include a five-card community hand. A resulting hand is derived by deriving a five-card resulting hand from the set of cards including the two-card starting hand and the five-card community hand.

[0014] In another particular embodiment, such a method according to the invention may be implemented in a draw poker game. The partial result of the draw poker game may include a group of one or more cards at particular locations within a dealt hand of cards, and the predetermined partial result(s) includes one or more predetermined groups of cards. The draw poker game is completed to provide a complete result by allowing one or more cards of the dealt hand to be discarded and replaced by draw cards to create a resulting hand. A payout for the complete result is determined by comparing the resulting hand to a payable to determine the payout, if any, that corresponds to the resulting hand. The payout for the resulting hand is adjusted using the awarded bonus value if the group of cards corresponds to any of the predetermined groups of cards. In a more particular embodiment, the particular locations include one or more card locations of the dealt hand of cards. In another embodiment, card values themselves, regardless of their locations, may serve as the criteria to be matched to the predetermined partial hands. The invention may be similarly applied to stud poker, without the discard/draw aspect.

[0015] In another particular embodiment, such a method according to the invention may be implemented in a blackjack poker game. The partial result of the blackjack poker game may include the first two cards dealt to the participant of the blackjack game. The blackjack game may be completed to provide a complete result by allowing zero, one or more additional cards to be dealt to the participant to create a resulting hand. A payout for the complete result may be determined by comparing the resulting hand to a dealer's hand, and covering a participant wager if the resulting hand has a higher poker rank than the dealer's hand. This resulting payout may then be adjusted using the awarded bonus value if the first two cards dealt to the participant correspond to any of the predetermined partial results. In a more particular embodiment, the predetermined partial results may involve predetermined two-card combinations.

[0016] In another particular embodiment, such a method according to the invention may be implemented in a "slot

game" of the type where symbols are presented, and certain symbol combinations provide winning payouts. The partial result of the slot game may involve a group of one or more symbols at respective reel locations, and the predetermined partial results may involve one or more predetermined symbol combinations. The slot game is completed to provide a complete result by presenting additional symbols at additional reel locations to reveal resulting paylines, and a payout for the complete result is determined by comparing the resulting paylines to a payable to determine the payout, if any, that corresponds to the resulting paylines. This payout for the resulting paylines may be adjusted using the awarded bonus value if the group(s) of symbols corresponds to any of the predetermined symbol combinations. Such a slot game embodiment may be implemented in mechanical and/or electronic embodiments.

[0017] In accordance with another embodiment of the invention, a method is provided for facilitating play of a poker game, where resulting hand payout awards are provided for particular resulting hands. Such a method includes correlating one or more particular starting hands with one or more bonus values, and providing at least one starting hand to each of player(s) participating in the poker game. It is determined whether the starting hand(s) of each player matches any of the particular starting hands, and if so, reserving the bonus value corresponding to the matching particular starting hand for use in determining the respective player's total payout award. At least one resulting hand is created for each of the players, and it is determined whether the resulting hand(s) of each player matches any of the particular resulting hands, and if so, awarding the corresponding resulting hand payout award. The resulting hand payout award is increased to arrive at the player's total payout award by increasing the player's total payout award as a function of the respective reserved bonus value. In more particular embodiments, a player may fold prior to receiving some or all of the additional cards used in the creation of the resulting hand.

[0018] In accordance with another embodiment of the invention, a method is provided for facilitating play of a poker game. The method involves providing a first payable of one or more designated starting hands of cards representing a subset of a set of available starting hands of cards. A multiplier is associated with at least some, or all, of the designated starting hands. A player starting hand of cards is provided to a participant of the poker game, and the player starting hand is compared to the designated starting hands to identify whether an associated multiplier is available for the player's starting hand. One or more additional cards are provided for use with the player starting hand to create one or more player resulting hands. A second payable is provided that identifies a plurality of designated resulting hands and associated payout values. The player resulting hands are compared to the designated resulting hands, and any associated payout values of the player resulting hands that correspond to any of the designated resulting hands are identified. A total payout value is calculated for each of the player resulting hands by multiplying the identified associated multiplier and the identified associated payout values of each of the player resulting hands.

[0019] In accordance with another embodiment of the invention, a method is provided for facilitating play of a Hold'em poker game. The method involves providing a first

paytable of one or more designated starting hands of cards representing a subset of a set of available starting hands of cards. A multiplier is associated with each of the designated starting hands, and a player starting hand of cards is provided to a participant of the Hold'em poker game. The player starting hand is compared to the designated starting hands, and an associated multiplier is identified if the player starting hand corresponds to any of the designated starting hands. One or more additional cards are provided for use with the player starting hand to create a player resulting hand. A second paytable is provided identifying a plurality of designated resulting hands and associated payout values. The player resulting hand is compared to the designated resulting hands, and the associated payout value of the player resulting hand is identified if it corresponds to any of the designated resulting hands. If an associated multiplier has been identified by way of the player starting hand corresponding to any of the designated starting hands, a total value is calculated by multiplying the identified multiplier and the identified payout value.

[0020] In more particular embodiments of such a Hold'em embodiment, associating a multiplier with each of the designated starting hands involves associating a different multiplier with each of the designated starting hands. In another embodiment, associating the multiplier involves associating a common multiplier with at least some of the designated starting hands, and associating different multipliers some or all of the remaining designated starting hands.

[0021] In another embodiment of the invention, a method is provided for facilitating play of a video Hold'em poker game by a participant. The method involves providing a first paytable of designated hole card combinations, associating a multiplier with each of the designated hole card combinations, and providing a player starting hand including player hole cards to the participant. The player hole cards are compared to the designated hole card combinations, and the associated multiplier is identified if the player hole cards match any of the designated hole card combinations. At least one set of one or more additional cards are provided for use with the player starting hand to create a player resulting hand. A second paytable is provided identifying a plurality of designated resulting hands and associated payout values. The player resulting hand is compared to the plurality of designated resulting hands, and the associated payout value of the player resulting hand is identified if it corresponds to any of the designated resulting hands. If a multiplier has been identified due to the player hole cards matching any of the designated hole card combinations, a total payout value is calculated by multiplying the multiplier and the identified payout value.

[0022] According to more particular embodiments of such a video Hold'em embodiment, a plurality of selectable player starting hands may be presented, and the system may allow the participant to select at least one of the selectable player starting hands. The selected player starting hand then represents the player starting hand. In another embodiment, providing at least one set of one or more additional cards involves providing a multiple-card community hand. In another embodiment, providing at least one set of one or more additional cards involves providing a plurality of community hands, where a player resulting hand is created from each combination of the player starting hand and the respective community hands. In still another embodiment,

an initial payout may also be associated with each of the designated hole card combinations. Such an initial payout may be dependent on a participant wager amount that increases as the participant wager amount increases, such as, for example, increasing proportionately to the participant wager amount. In another embodiment, at least one of the initial payouts provides a positive initial payout award, and at least one of the initial payouts provides zero payout award. In another embodiment, the initial payout is awarded to the participant only if the payout value identified for the resulting hand is less than an amount of the initial payout, while in other embodiments the initial payout is awarded to the participant only if the payout value identified for the resulting hand is zero.

[0023] In accordance with another embodiment of the invention, a computer-implemented gaming apparatus for allowing player participation in an electronic gaming activity is provided. The gaming apparatus includes a display, a first paytable identifying one or more predetermined partial results and corresponding bonus values for each of the predetermined partial results, and a second paytable identifying one or more predetermined complete results and corresponding resulting payouts for each of the predetermined complete results. A processor is configured to direct the display to present at least one partial result of the electronic gaming activity to the player and award a bonus value based on the partial result if the partial result matches any of the predetermined partial results of the first paytable. The processor is further configured to complete the gaming activity to provide a complete result and determine a payout for the complete result, and to adjust the payout for the complete result using the awarded bonus value to provide a final payout if a bonus value was awarded.

[0024] In accordance with another embodiment of the invention, a computer-implemented poker apparatus for allowing player participation in an electronic poker game is provided. The poker apparatus includes a display, a first paytable identifying one or more predetermined partial hands and corresponding bonus values for each of the predetermined partial hands, and a second paytable identifying one or more predetermined resulting hands and corresponding resulting payouts for each of the predetermined resulting hands. A processor is configured to direct the display to present at least one partial hand of the electronic poker game to the player and award a bonus value based on the partial hand if the partial hand matches any of the predetermined partial hands of the first paytable. The processor is further configured to direct the display to present one or more additional cards available for combination with the partial hand to arrive at a resulting hand, to determine a resulting payout for the resulting hand if the resulting hand matches any of the predetermined resulting hands of the second paytable, and to adjust the resulting payout for the resulting hand using the awarded bonus value to provide a final payout if the partial hand matched any of the predetermined partial hands of the first paytable.

[0025] According to more particular embodiments of such a poker apparatus, the processor is configured to direct the display to present a plurality of the partial hands, where the poker apparatus further includes a user interface to facilitate player selection of at least one of the partial hands. According to another embodiment, the bonus values are multiplier values, where the first paytable includes a list of the prede-

terminated partial hands and their corresponding multipliers. In another embodiment, the bonus values further include fixed payout values payable to the player if the resulting hand does not match any of the predetermined resulting hands of the second payable, or alternatively if the resulting hand provides a resulting payout that is less than the fixed payout value.

[0026] In accordance with another embodiment of the invention, a computer-readable medium is provided having instructions stored thereon that are executable by a computer system for facilitating play of a gaming activity by performing steps including awarding a bonus value based on a partial result of the gaming activity if the partial result corresponds to any of one or more predetermined partial results, completing the gaming activity to provide a complete result and determining a payout for the complete result, and if the partial result corresponds to any of the one or more predetermined partial results, adjusting the payout for the complete result using the awarded bonus value to provide a final payout.

[0027] In accordance with another embodiment of the invention, a computer-readable medium is provided having instructions stored thereon that are executable by a computer system for facilitating play of a Hold'em poker game by performing steps including providing a first payable of designated hole card combinations, associating a multiplier with each of the designated hole card combinations, providing a player starting hand including player hole cards to the participant, comparing the player hole cards to the designated hole card combinations, and identifying the associated multiplier if the player hole cards match any of the designated hole card combinations. The executed steps further include providing at least one set of one or more additional cards for use with the player starting hand to create a player resulting hand, providing a second payable of a plurality of designated resulting hands and associated payout values, comparing the player resulting hand to the plurality of designated resulting hands, and identifying the associated payout value of the player resulting hand if it corresponds to any of the designated resulting hands. The executed steps further include calculating a total payout value by multiplying the multiplier and the identified payout value, if a multiplier has been identified due to the player hole cards matching any of the designated hole card combinations.

[0028] These and various other advantages and features of novelty which characterize the invention are pointed out with particularity in the claims annexed hereto and form a part hereof. However, for a better understanding of the invention, its advantages, and the objects obtained by its use, reference should be made to the drawings which form a further part hereof, and to accompanying descriptive matter, in which there are illustrated and described representative examples of systems, apparatuses, and methods in accordance with the invention.

BRIEF DESCRIPTION OF THE DRAWINGS

[0029] The invention is described in connection with the embodiments illustrated in the following diagrams.

[0030] FIG. 1 illustrates a representative manner for facilitating play in a gaming activity, and enabling payout awards to be manipulated based on partial game criteria, in accordance with one embodiment of the present invention;

[0031] FIGS. 2A, 2B and 2C illustrate representative examples of paytables that may be used as the auxiliary bonus criteria for the partial results of the gaming activity;

[0032] FIGS. 3A and 3B illustrate additional payable examples further including paytables relating to exemplary final outcomes of the gaming activity;

[0033] FIGS. 4A, 4B and 4C are diagrams illustrating a progression of a Hold'em poker hand played in accordance with one embodiment of the present invention;

[0034] FIG. 5 illustrates an embodiment of the invention allowing player selection of a partial result from a plurality of available partial results;

[0035] FIG. 6 illustrates an embodiment of the invention allowing player selection of a starting hand from a plurality of available starting hands in a poker embodiment;

[0036] FIG. 7 generally illustrates the applicability of the present invention in, among other things, a variety of poker games including one or more starting hands and additional cards such as one or more community cards;

[0037] FIG. 8 illustrates an alternative embodiment of a Hold'em-type poker game implementing the principles of the present invention, and facilitating multi-hand play by the participant(s) of the game;

[0038] FIG. 9 illustrates another embodiment of a Hold'em-type poker game wherein multi-hand play by the participant is allowed through participation with multiple boards and/or multiple starting hands;

[0039] FIG. 10 illustrates an example of how total payouts may be calculated in view of varying bet amounts and varying numbers of concurrent hands played;

[0040] FIGS. 11A, 11B and 11C are diagrams illustrating a progression of an exemplary draw poker hand played in accordance with one embodiment of the present invention;

[0041] FIGS. 12A, 12B and 12C are diagrams illustrating a progression of an exemplary blackjack poker game which implements principles of the present invention;

[0042] FIG. 13 is a diagram illustrating a representative example in which the present invention may be integrated into a slot game;

[0043] FIG. 14 illustrates a representative embodiment of a casino-style gaming device in which the principles of the present invention may be applied;

[0044] FIG. 15 illustrates a representative example of a computing system capable of carrying out operations in accordance with the invention;

[0045] FIG. 16 illustrates an exemplary table layout for participating in a poker game implementing one embodiment of the present invention;

[0046] FIG. 17 is a flow diagram directed to a general embodiment of the present invention which introduces additional/bonus payout awards into gaming activities;

[0047] FIG. 18 is a flow diagram illustrating a community hand poker method implementing the principles of the present invention;

[0048] FIG. 19 is a flow diagram illustrating one particular embodiment of a Hold'em embodiment implementing one embodiment of the invention;

[0049] FIG. 20 is a flow diagram illustrating a representative embodiment of the invention in connection with a draw poker methodology; and

[0050] FIG. 21 is a flow diagram illustrating one particular embodiment of the invention in a slot game context.

DETAILED DESCRIPTION OF THE INVENTION

[0051] In the following description of various exemplary embodiments, reference is made to the accompanying drawings which form a part hereof, and in which is shown by way of illustration various embodiments in which the invention may be practiced. It is to be understood that other embodiments may be utilized, as structural and operational changes may be made without departing from the scope of the present invention.

[0052] Generally, the present invention provides a manner of introducing bonus or otherwise additional payout awards into gaming activities. In various forms, the invention utilizes a subset(s) of the gaming elements/items otherwise associated with the gaming activity to determine whether a conditional payout increase, contingent upon a final result of the gaming activity, will be awarded. The invention may be integrated with a variety of different known gaming activities, or introduced into new gaming activities, where such a subset(s) of the gaming elements is already available or can be devised.

[0053] FIG. 1 illustrates one embodiment of a manner for facilitating play in a gaming activity, and enabling payout awards to be manipulated based on partial game criteria. In the illustrated embodiment, a poker game 100 is depicted, which includes a partial hand(s) 102, one or more completing cards 104, and a final or "resulting" hand(s) 106. A partial hand 102 may be represented by, for example, the starting hand or "hole cards" in a Hold'em poker game. The completing cards 104 represent any cards that are available for use together with the partial hand 102 in creating a final or resulting hand 106. For example, the completing cards may represent the community cards in a Hold'em poker game. In a Hold'em context, the resulting hand 106 may be derived from the set of cards comprising the partial hand 102 (e.g., hole cards) and the completing cards 104 (e.g., community cards).

[0054] Various games such as Hold'em poker, draw poker, blackjack, and the like often include a first set or group of cards that are provided to the player. Additional cards are generally provided to provide the player with an opportunity to better his/her hand, in an ultimate effort to maximize a resulting payout award. Some games such as Hold'em poker may allow multiple bets to be placed during play of the hand, such as upon receipt of the hole cards, and again after each of the flop, the turn, and the river. However, such wagers are merely additive wagers placed on only what the final hand will be. The particular cards provided along the way to the final hand are irrelevant in and of themselves, and are relevant only at the time that the final hand is derived from the aggregation of the cards. This holds true for other poker games as well, such as draw poker, blackjack, etc.

[0055] The present invention provides, among other things, a manner of making a subset(s) of the cards in such games independently relevant of the final result, while still impacting the final result. An example is shown in FIG. 1, which is described in terms of a poker game. The partial hand(s) 102 may be a natural starting hand such as in the case of the hole cards in Hold'em, or may be established in advance such as particular dealt cards, the dealt location of cards, and/or other predetermined criteria. In the embodiment of FIG. 1, auxiliary bonus criteria 108 are established. These criteria 108 may be established in any manner, such as by way of a paytable. An example is shown in TABLE 1 below:

TABLE 1

AUXILIARY BONUS CRITERIA	BONUS VALUE
2 Red Aces	W
Suited Ace/King	X
Pair of Aces	Y
Pair of Kings, Queens, or Jacks	Z

Thus, the auxiliary bonus criteria of "2 Red Aces" indicates that if the partial hand 102 includes or equals 2 Red Aces, a bonus value of "W" will apply. For example, the bonus value W may correspond to a multiplier of five. This will be described more fully below.

[0056] Payouts for the final hand 106 are also determined by predetermined final hand payout criteria 110, such as poker rank, as shown in the example paytable of TABLE 2:

TABLE 2

FINAL HAND	PAY
Royal Flush	A
Straight Flush	B
...	...
Two Pairs	n

Thus, if a player's final hand 106 is complete, it is determined 112 whether the player's final hand 106 meets any of the final hand payout criteria 110. If it does not, then no payout 114 is awarded. Assume for purposes of example that the final hand 106 includes a Straight Flush, and a Straight Flush is part of the payout criteria 110 as it is in the example of TABLE 2. In such case, the player's final hand 106 meets the final hand criteria, and the player would be awarded a payout 116 equal to some value shown as "A" in TABLE 2.

[0057] In accordance with the present invention, the payout 116 may be adjusted based on the partial hand(s) 102 occurring prior to formulation of the final hand(s) 106. For example, if the partial hand 102 meets the auxiliary bonus criteria 108 as determined at decision block 118, the bonus is applied 120, and the payout is awarded with the bonus applied as shown at block 122. If a payout 116 applies but the bonus criteria have not been met, then only the payout is awarded 124 in the illustrated embodiment. More particular examples are provided in the ensuing description.

[0058] FIGS. 2A, 2B and 2C illustrate representative examples of paytables that may be used as the auxiliary bonus criteria for the partial results of the gaming activity. For purposes of example and not of limitation, these figures

are described in the context of a Hold'em poker game where the partial hand is represented by the starting hand or "hole cards." The first payable 200 of FIG. 2A includes a number of predetermined starting hand types as shown in column 202. Assuming two hole cards as is the case in most Hold'em-style poker games, these starting hand types may include, for example, two red Aces, suited cards such as a suited Ace/King, pairs such as pairs of Aces, Kings, Queens, Jacks, and/or other predetermined card combinations. In accordance with the invention, at least some or all of these predetermined card combinations are associated with a bonus value, which in the exemplary payable 200 is a multiplier as shown in column 204, although it could represent other mathematical functions and/or combinations of mathematical functions. It should be noted that the particular multiplier values in column 204 may, or may not, be dependent on the amount wagered by the player. Further, the multiplier may be an integer value, or may be any number including fractional values (e.g., 1.5, 2-1/2, etc.).

[0059] For payable 200, receiving a suited Ace/King as the starting hand would specify a multiplier of "5" as the bonus value. Similarly, a pair of Aces as the hole cards would specify a multiplier of "7." When a player receives a starting hand that corresponds to any of the predetermined starting hand types designated in the payable 200 column 202, the player will be awarded the corresponding multiplier. It should be noted that the "award" of this multiplier does not, in and of itself, provide the player with any current return or payout. Rather, this multiplier is in essence "reserved" for the player, and is used later in the hand to adjust a subsequent payout amount. For example, if the player wins a payout of \$10 based on his/her final hand, and the multiplier of "5" was previously awarded to that player during that hand, then the player would win a total payout of \$10x5=\$50. In one embodiment, if the player's final/resulting hand did not result in a payout, then the multiplier would have no effect (e.g., \$0x5=\$0).

[0060] However, the bonus value awarded to the player may also include a non-contingent award as well. Paytable 210 of FIG. 2B illustrates one such example. In this example the bonus value provides a fixed or relative payout, which may be used in addition to serving as a multiplier or other bonus function. Using reference numbers analogous to those of FIG. 2A where appropriate, the starting hand column 202 includes a number of predetermined starting hand types as previously described. A bonus value in the "pay" column 212 provides a payout amount for one or more of the starting hand types. For example, where the player's starting hand includes a pair of Aces, a pay amount is shown as "2." This value may represent dollars, tokens, credits, and/or the like. The value may, or may not, be dependent on an amount wagered by the player. For example, where the player wagers 2 credits, the "pay" column 212 may be as illustrated on payable 210, but where the player wagers 4 credits the pay column 212 may be doubled.

[0061] Paytable 220 of FIG. 2C illustrates an example implementing combined partial hand bonus criteria. Paytable 220 includes the starting hand type 202, pay column 212, and multiplier 204. For example, in a Hold'em embodiment where the player receives two red Aces as his/her hole cards, the player will be awarded a payout of "3" units (e.g.,

credits), and a multiplier of "10" will be reserved for use in calculating a total payout when the player's final hand is complete.

[0062] It should be noted that the paytables 200, 210, 220 of FIGS. 2A, 2B and 2C are merely representative examples. Any predetermined, or even partially random, hand types and corresponding bonus values may be utilized. In many cases, the starting hand types and corresponding bonus values are at least in part dependent upon the mathematical payout criteria.

[0063] FIGS. 3A and 3B illustrate additional payable examples, and further include paytables relating to the final outcome of the gaming activity. Referring first to payable 300 of FIG. 3A, and again using reference numbers from FIGS. 2A, 2B and 2C where appropriate, a first portion of the payable 300 includes a payable 220 similar to that described in connection with FIG. 2C. This portion 220 includes the starting hand type 202, pay column 212, and multiplier column 204 as previously described. The payable 300 further includes a second portion 302 that includes a listing of the final hand types 304 that will produce a payout. The particular payout for a particular hand type is shown in the pay column 306. For example, four Aces (FOUR A'S) will provide a 25 unit payout.

[0064] From the payable 300, a total payout award may be calculated for a player for a particular hand. As an example in the Hold'em context, assume the player receives a pair of Kings (K,K) as the hole cards. The player will be awarded a payout of "1" unit as seen at the intersection of row 308 and column 212. A multiplier value of "2" will also be awarded to the player as seen at the intersection of row 308 and column 204. As play continues, assume the player's final hand is a full house (e.g., K,K,3,3,3). As seen at the intersection of row 310 and column 306, the player will be awarded a payout of "5" units. The player's final payout will therefore be as shown in EQUATION 1 below:

$$\text{PAY}_{\text{COLUMN } 212} + (\text{PAY}_{\text{COLUMN } 306} \times \text{MULT}_{\text{COLUMN } 204}) = 1 + (5 \times 2) = 11 \quad \text{EQUATION 1}$$

[0065] It should be noted, however, that other embodiments of the invention provide the PAY_{COLUMN 212} only if the resulting hand does not provide a greater amount. In other words, in one embodiment, the pay 212 amount will be paid to the player if the player does not ultimately obtain a resulting hand that provides a payout. In such an embodiment, the PAY amounts shown in column 212 are provided as a default payment for meeting one of the starting hand criteria 202, when the awarded multiplier or other bonus value obtained cannot be applied because it is contingent upon receiving a payout on the resulting hand. In another embodiment, the PAY_{COLUMN 212} is provided only if the resulting hand does not provide any amount. Such an embodiment is shown in EQUATION 2 below:

[0066] If PAY_{COLUMN 306}=0, Final Payout=PAY_{COLUMN 212}=1

$$\text{Else } \text{PAY}_{\text{COLUMN } 306} \neq 0, \text{ Final Payout} = (\text{PAY}_{\text{COLUMN } 306} \times \text{MULT}_{\text{COLUMN } 204}) = 5 \times 2 = 10 \quad \text{EQUATION 2}$$

[0067] EQUATION 1 assumes a first player wager amount, such as a bet of "1" as shown by bet block 312. Paytable 320 of FIG. 3B, on the other hand, assumes a different player wager amount, such as a bet of "5" as shown by bet block 312. Certain payouts and/or bonus values may

be increased proportionally to the wager, or increased in some manner, as the player's wager increases. In the illustrated embodiment of **FIG. 3B**, the pay column **212** has increased proportionally to the increased wager as compared to **FIG. 3A**. More particularly, because the player bet is "5" in the example of **FIG. 3A**, and the player bet is "1" in the example of **FIG. 3A**, some of the payout amounts are increased by a factor of "5" in the example of **FIG. 3B**. Specifically, the pay column **212** has been increased by a factor of "5" over the pay column **212** of **FIG. 3A**, and the pay column **306** of **FIG. 3B** has also increased by a factor of "5" over the pay column **306** of **FIG. 3A**. It is noted that in the illustrated example, the multiplier values in column **204** of **FIGS. 3A and 3B** did not change as a result of the increased bet amount **312**, although it could also change if desired.

[0068] **FIGS. 4A, 4B and 4C** are diagrams illustrating a progression of a Hold'em poker hand played in accordance with one embodiment of the present invention. As will be described more fully below, various options may exist such as allowing user selection among a plurality of available starting hands, playing multiple hands simultaneously using multiple community card hands, etc. For purposes of illustration and not of limitation, the embodiment of **FIGS. 4A, 4B and 4C** are illustrated using a single starting hand and a single community card hand. Further, the principles described in connection with **FIG. 4A** are equally applicable to other community card games involving a partial/starting hand. It should also be noted that the term "community" when used herein in the context of community cards, community hand, community card games and the like is a term used in the art to represent additional cards, often referred to as the "board." The use of the term "community" does not, as used herein, necessarily require that these additional cards or board(s) be available for use with multiple players, although this may be the case. Thus, in embodiments involving a single player or multiple players, the community hand represents the additional presented cards that are available to the single or multiple players in creating their respective resulting hand(s). In other words, in some embodiments of the invention the "community" cards do not necessarily need to be "shared" by multiple players, such as in an embodiment where a single participant is participating in the game. In multi-player embodiments, the community cards may indeed be shared by multiple players.

[0069] As shown in **FIG. 4A**, the starting hand **400** includes two cards **402, 404** in the illustrated embodiment, although a smaller or larger number may be used. The board **406** represents the community cards that are used as additional cards to assist in creating the player's final or resulting hand. In the illustrated embodiment, five community cards **408, 410, 412, 414, 416** constitute the board **406**, although a smaller or larger number of community cards may be used. A starting hand payable **420** is provided, which identifies predetermined starting hand types and corresponding multiplier values. Resulting hand payable **422** identifies predetermined resulting hands and corresponding payout amounts.

[0070] Referring to **FIG. 4B**, the player has received a pair of Aces (A,A) as cards **402, 404** of the starting hand **400**. The payable **420** indicates that the player will therefore be entitled to multiply any payout associated with a resulting hand by "5" as shown at row **424**. In some embodiments,

any received multiplier value may be displayed to the player as shown by presentation field **426**. This may be particularly useful in a video embodiment, although it may be used in live table embodiments as well. Alternatively, the multiplier may simply be used in the total payout calculation without any specific presentation. In the illustrated example, no starting hand payout is provided (see, e.g., column **212** of **FIGS. 2B, 2C, 3A, 3B**), although in other embodiments such a starting hand payout may be provided.

[0071] **FIG. 4C** illustrates a final progression stage of the poker hand, where the cards **408, 410, 412, 414, 416** of the board **406** are exposed. The cards of the board **406** may all be exposed at once, or may be exposed sequentially, or in any predetermined manner. In one embodiment, additional bets are allowed such that the player may place additional bets after one or more of the cards **408-416** are exposed. For example, the first three cards **408, 410, 412** (i.e., the flop) may be exposed, and the player may place an additional bet. The fourth card **414** (i.e., the turn) may be exposed, allowing the player to place another bet. The last card **416** (i.e., the river) may then be exposed, and further bets may be placed. This is dependent on the particular implementation. For example, the additional bets may be implemented in embodiments where multiple players are participating against each other, and additional total payouts due to the existence of a multiplier are paid by the house (in which case monies are paid to the house to fund such payouts). In a slot machine context, there may not be such additional wagers, and exposing the cards of the board **406** may be performed in any desired manner (e.g., all at once, sequentially, etc.).

[0072] In the illustrated embodiment of **FIG. 4C**, the player's resulting hand is derived using a number of cards (five in the present example) selected from the total cards in the starting hand **400** and board **406**. In the illustrated embodiment, the player has received a Flush of diamonds (A, K, 10, 8, 5 of diamonds). From the resulting hand payable **422**, it can be seen at row **428** that a Flush pays "10" units. In accordance with the present invention, the previous multiplier of "5" awarded to the player as a result of the qualifying starting hand **400** is multiplied by the "10" units awarded to the player as a result of the player's resulting hand. Thus, the total payout is "10" units times the multiplier of "5" for a total payout of "50."

[0073] It is interesting to note that the "pair" of Aces received in the starting hand **400** resulted in a multiplier that caused an additional payout amount, even though the "pair" of Aces in the starting hand **400** were not used in the resulting hand (only the Ace of diamonds was used). Thus, in this embodiment, the multiplier is awarded regardless of how the starting hand cards (that gave rise to the multiplier) are ultimately used. In fact, the multiplier still applies even if none of the starting hand cards **402, 404** are used in the resulting hand (e.g., a three-seven Straight occurs on the board **406** cards).

[0074] In another embodiment, the multiplier or other bonus value may be used only where all of the starting hand cards are ultimately used in the resulting hand. For example, where a pair of Aces is received in the starting hand **400** giving rise to a multiplier of "5," a resulting hand utilizing that pair of Aces will allow the multiplier to be used. More particularly, resulting hands including four Aces, a full

house, three of a kind, two pair, or other designated poker rank that includes the two Aces **402**, **404** will give rise to the use of the multiplier.

[0075] The present invention may be implemented with various alternative embodiments. One such alternative embodiment is to allow the player to select a starting hand(s) from a plurality of starting hands. **FIG. 5** generally illustrates such an embodiment. As can be seen, a plurality of starting hands **500**, **502** through **504** may be presented to the user. The number presented to the user may be two, three, or any other number from which a reasonable selection may be made. The cards of each of the starting hands **500**, **502**, **504** may be presented face up, face down, some face up and some face down, or in any desired manner. In one embodiment of the invention, the plurality of starting hands **500**, **502**, **504** are each presented face up, thereby allowing the player to select the starting hand that is believed to be the most likely to result in a favorable resulting hand, and/or the starting hand that is associated with a bonus value (e.g., multiplier) or the highest bonus value if multiple starting hands are associated with bonus values. The selected starting hand is then used in combination with the hand of community cards, i.e., the board **506**, to derive the resulting hand. It should also be noted that in some embodiments, multiple starting hands may be selected by the player, such as in an embodiment where the player is allowed to participate (with or without multiple wagers) in multiple hands by playing multiple starting hands.

[0076] **FIG. 6** illustrates a more particular embodiment of the invention involving selection of a starting hand. In this embodiment, a starting hand payable **600** is provided, which lists the starting hand criteria **602**, as well as a payout **604** and multiplier **606** if the player's selected starting hand matches one of the predetermined starting hands in column **602**. A resulting hand payable **610** is also provided, which lists the resulting hand criteria **612**, as well as the payout **614** to be awarded to the player if the player's resulting hand matches one of the predetermined resulting hands in column **614**.

[0077] As illustrated in **FIG. 6**, the player has been presented with (e.g., dealt) two possible starting hands **620**, **622**, although a larger number may have been dealt. Starting hand **620** does not meet the starting hand criteria **602**, and therefore has no pay **604** or multiplier **606** associated therewith. On the other hand, starting hand **622** includes a suited Ace/King **623**, **624** (A,K Spades), which matches one of the starting hand criteria **602** as shown at row **625**. This particular starting hand has a "pay"**604** value of "0," meaning that no automatic payout is awarded for achieving this particular starting hand. However, a multiplier of "3" is awarded for this starting hand **622**. In the illustrated embodiment, the player selects starting hand **622**. This selection may be made in any known manner, whether played via a live table version or slot machine version. For example, in a slot machine embodiment, the user may select the desired starting hand **622** using any known user interface mechanism, such as a button, pointer, touchscreen, voice command, etc.

[0078] The board **626** in the illustrated embodiment includes five cards **630**, **632**, **634**, **636**, **638**. Using five of the total seven cards to derive the best possible resulting hand, a Full House becomes the resulting hand **640** (i.e., two Aces,

three Kings). A Full House is listed on the resulting hand payable **610**, and provides a payout of "5" as shown at row **642**. Therefore, the previously awarded multiplier of "3" shown at row **625**, taken times the payout value of "5" shown at row **642**, results in a total payout of 15 units.

[0079] It is noted that had the player selected the other starting hand **620**, the player would not have been awarded any bonus value (e.g., multiplier), nor would the player have won any payout. In one embodiment of the invention, the non-selected starting hand(s) is still displayed to the player, so that the player can see what would have been won had he/she selected a different starting hand.

[0080] In one embodiment, the cards of the starting hand that are not selected, such as starting hand **620**, are not "returned to the deck(s)" of cards that are subsequently used for the board cards **626**. In another embodiment, the cards of the starting hand that are not selected, such as starting hand **620**, are returned to the deck(s) of cards and are therefore available for use as cards of the board **626**.

[0081] As seen above, the present invention is particularly interesting in the context of Hold'em poker games. As shown in **FIG. 7**, the present invention is applicable in any Hold'em-type poker game where at least one board **700** including one or more cards **702A . . . 702B**, and one or more provided or selectable starting hands **704**, **706** each including one or more cards **708A . . . 708B**, **710A . . . 710B** respectively. Other alternatives also exist, and the invention may be applied in other environments beyond community card poker games such as Hold'em. Some representative examples of such alternatives and different environments follow.

[0082] **FIG. 8** illustrates an alternative embodiment of a Hold'em-type poker game implementing the principles of the present invention, and facilitating multi-hand play by the participant(s) of the game. Again, one or more provided or selectable starting hands **800**, **802** are provided. In the illustrated embodiment, multiple boards **804**, **806** through **808** are provided to allow the player to simultaneously participate in multiple hands. There may be one board, two boards, three boards, or any number of boards that is reasonable in the gaming context. Multiple boards may be presented as a standard part of the game, or may be presented upon user selection of participating in multiple games, which may require additional wagers by the player. For example, if a wager of a single unit allows participation in one hand with one board **804**, then a wager of three units may allow for participation in three hands with three boards **804**, **806**, **808**. More particular examples are set forth in **FIG. 9**.

[0083] In the representative embodiment of **FIG. 9**, a starting hand payable **900** is provided, which lists the starting hand criteria **902**, as well as a payout (PAY-1) **904** and multiplier (MULT) **906** if the player's selected starting hand matches one of the predetermined starting hands in column **902**. A resulting hand payable **910** is also provided, which lists the resulting hand criteria **912**, as well as the payout (PAY-2) **914** to be awarded to the player if any one or more of the player's resulting hands match any of the predetermined resulting hands in column **912**.

[0084] The embodiment of **FIG. 9** also allows player selection of a starting hand, so the player has been dealt two

possible starting hands **920**, **922** (although any number may have been presented). Starting hand **920** does not meet the starting hand criteria **902**, and therefore has no associated pay **904** or multiplier **906**. Starting hand **922** includes a suited King/Queen (K,Q Spades), which matches one of the starting hand criteria **902** as shown at row **924**. This particular starting hand has a “pay”**904** value of “1,” meaning that “1” unit is awarded to the player regardless of any further results. Further, a multiplier of “3” is awarded for this starting hand **922**. In the illustrated embodiment, the player selects starting hand **922**.

[**0085**] The present invention supports the use of multiple boards to allow multi-hand play by the player. The embodiment of **FIG. 9** includes three boards **930**, **932**, **934**, each of which includes five cards. Using the best five cards from the set of cards including the player’s selected starting hand **922** and each respective board **930**, **932**, **934**, three five-card resulting hands **940**, **942**, **944** are formed.

[**0086**] Table **950** summarizes the payouts for each of these resulting hands **940**, **942**, **944**. Because the player’s selected starting hand **922** met one of the starting hand criteria **902**, the PAY-**1904** may apply for all three played hands. However, in one embodiment of the invention, the PAY-**1904** is only awarded to the player if the player does not receive a payout on a particular resulting hand to which an awarded multiplier can be applied to. In the illustrated embodiment of **FIG. 9**, it is assumed that the PAY-**1904** amount is paid only if a higher result is not obtained by way of the resulting hand. The multiplier value (MULT) of “3” is shown in table **950** for each of the resulting hands. This is because the selected starting hand **922** met the starting hand criteria **902** as shown in row **924**, and therefore applies to each of the resulting hands.

[**0087**] Resulting hand **940** is derived from the cards including the selected starting hand **922** and the board **930**. The highest poker rank that can be obtained from these cards is a pair of Twos, as shown in resulting hand **940**. Resulting hands **942** and **944** are derived in an analogous fashion. Resulting hand **942** has produced Three of a Kind (three Queens), and resulting hand **944** has produced a Royal Flush (A,K,Q,J,10 Spades). Therefore, the PAY-**2914** for resulting hand **940** is “0,” the PAY-**2914** for resulting hand **942** is “5” as shown on row **946**, and the PAY-**2914** for resulting hand **944** is “500” as shown on row **948**.

[**0088**] In accordance with the present invention, each of the PAY-**2914** payouts can be adjusted by an awarded bonus value, which is a multiplier in the present example. Because resulting hand **940** did not result in any PAY-**2914** award, then the PAY-**1904** amount of “1” unit is awarded as shown in table **950**. Resulting hand **942** resulted in a payout (PAY-**2**) **914** of “5,” so the PAY-**1** is disregarded. However, the multiplier of “3” is applied to the PAY-**2** of “5,” resulting in a total payout for resulting hand **942** of “15” units. For the Royal Flush in resulting hand **944**, the payout (PAY-**2**) of “500” units, which is then multiplied by the multiplier of “3,” resulting in a total payout of “1500” units for resulting hand **944**. The aggregate total payout for the multi-hand play is therefore $1+15+1500=1516$ units.

[**0089**] In one embodiment, the cards in each of the boards **930**, **932**, **934** are provided from separate decks of cards. In another embodiment, a single deck of cards may supply all of the cards of the multiple boards **930**, **932**, **934**. In still

other embodiments, X number of decks may supply the cards for Y number of boards, where X and Y represent any positive number while ensuring that an adequate supply of cards is available for the board cards.

[**0090**] It should be noted that multi-hand games may also be played using multiple starting hands and a single board. For example, the player can be provided with (or select) multiple starting hands, each of which may be used with a common board to provide a number of resulting hands equal to the number of provided/selected starting hands. In other multi-hand embodiments, both multiple starting hands and multiple boards may be used, to provide a number of resulting hands equal to the number of provided/selected starting hands times the number of available boards.

[**0091**] **FIG. 10** illustrates an example of how total payouts may be calculated in view of varying bet amounts and varying numbers of concurrent hands played. The paytable **1000** includes a first portion including the starting hand type **1002**, a first pay column **1004** referred to as PAY(**1_S**), a second pay column **1006** referred to as PAY(**10_S**), and a multiplier column **1008**. The PAY(**1_S**) column **1004** represents the payout awarded due to a matching starting (S) hand, where “1” unit is bet and the resulting hand does not result in a higher payout. The PAY(**10_S**) column **1006** represents the payout awarded due to a matching starting hand, where “10” units are bet and the resulting hand does not result in a higher payout. The paytable **1000** could include other PAY(**n_S**) columns for other bet amounts. Such columns **1004**, **1006** may be presented for each possible bet amount, or a single column may change in response to the player changing his/her wager amount.

[**0092**] The paytable **1000** further includes a second portion which lists the resulting hand types **1010** that will produce a payout. The particular payout for a particular hand type is shown in the pay columns **1012** and **1014**, depending on the bet amount. For example, if the player bets “1” unit, then PAY(**1_R**) of column **1012** is used as the payout amount, and if the player bets “10” units, then PAY(**10_S**) of column **1014** is used as the payout amount. Again, other PAY(**n_R**) columns may be provided for other bet amounts, or a single PAY(**n_R**) column may dynamically change in response to the player’s particular wager amount.

[**0093**] **FIG. 10** illustrates three representative examples. In **EXAMPLE-1**, the bet is “1” unit, and the number of hands bet (HAND BET) is “1,” resulting in a total bet amount of “1” unit. If the starting hand includes a Four of Hearts (4H) and a Six of Diamonds (6D), this does not match any of the starting hand types **1002**, and therefore the PAY(**1_S**) **1004** and MULT **1008** equal “0.” In such case, if the resulting hand is Two Pairs, then the PAY(**1_R**) equals “1,” thereby resulting in a total payout of “1” unit.

[**0094**] **EXAMPLE-2** of **FIG. 10** includes a bet amount of “1” unit, but differs from **EXAMPLE-1** in that the number of hands bet (HAND BET) is “3,” which results in a total bet of “3.” Assuming the starting hand includes two red Aces (i.e., Ace of Hearts and Ace of Diamonds), this matches a starting hand type **1002**. Because “1” unit was bet, the PAY(**1_S**) column **1004** determines the payout if no larger result ultimately occurs on the resulting hand. The PAY(**1_S**) amount for this matching starting hand type equals “1” unit. Further, the multiplier in column **1008** for this starting hand equals “6.” Because three hands are being concurrently

played in EXAMPLE-2, three resulting hands are produced. Assuming the first resulting hand is Two Pairs, the resulting hand payout $PAY(1_R)$ from column 1012 is "1" unit. However, because of the awarded multiplier of "6," the total payout for the first resulting hand is equal to "6." Assuming the second resulting hand is a Flush, the resulting hand payout $PAY(1_R)$ from column 1012 is "4" units, providing a total result for the second resulting hand of "24" units due to the multiplier of "6." Where the third resulting hand is a single pair of Aces, the resulting hand payout $PAY(1_R)$ from column 1012 is "0" units as it is not a qualifying resulting hand type 1010. In this case, no payout is provided due to the resulting hand, but the $PAY(1_S)$ amount of "1" unit is awarded to the player.

[0095] EXAMPLE-3 of FIG. 10 includes a bet amount of "10" units, and like EXAMPLE-2 involves three concurrently played hands (HAND BET equals "3"), resulting in a total bet of "30" units. Assuming the starting hand includes a suited Ace/King (e.g., A/K Clubs; A/K Spades; A/K Diamonds; A/D Hearts), this matches a starting hand type 1002. Because "10" units were bet, the $PAY(10_S)$ column 1006 determines the payout if no larger result ultimately occurs on the resulting hand. However, the $PAY(10_S)$ amount for this matching starting hand type equals "0" units. Further, the multiplier in column 1008 for this starting hand equals "3." Because three hands are being concurrently played in EXAMPLE-3, three resulting hands are produced. Assuming the first resulting hand is Two Pairs, the resulting hand payout $PAY(10_R)$ from column 1014 is "10" units. However, because of the awarded multiplier of "3," the total payout for the first resulting hand is equal to "30" units. Assuming the second resulting hand is four Aces, the resulting hand payout $PAY(10_R)$ from column 1014 is "250" units, providing a total result for the second resulting hand of "750" units due to the multiplier of "3." Where the third resulting hand is a single pair of Aces, the resulting hand payout $PAY(10_R)$ is "0" units as it is not a qualifying resulting hand type 1010. In this case, no payout is provided due to the resulting hand, and because the $PAY(10_S)$ was also "0" units.

[0096] As previously indicated, the present invention is applicable to other poker games. The partial result occurring prior to the resulting hand may be a natural starting hand as in the case of the hole cards in a Hold'em-type poker game, or may be a logical, or predetermined, subset of cards in any poker game. FIGS. 11A, 11B and 11C illustrate this by implementing the principles of the present invention with a draw poker game.

[0097] FIGS. 11A, 11B and 11C are diagrams illustrating a progression of a draw poker hand played in accordance with one embodiment of the present invention. While various options may exist such as allowing the player to concurrently participate in multiple draw poker hands, the present example is limited to a single hand. From the description provided herein, those skilled in the art can readily apply these principles to a multi-hand embodiment and/or other poker games involving a draw.

[0098] The example of FIGS. 11A, 11B and 11C assume a five-card draw poker game. In accordance with the present invention, a partial hand is used to determine an initial bonus value that may be applied to a resulting hand payout. This "partial hand" may be the cards that are held (i.e., not

discarded) by the player. In such an embodiment, various partial hand types may be provided, where some of these partial hand types may include different numbers of cards. For example, one predetermined qualifying partial hand may be a pair, if the player holds two cards and elects to draw three cards. Another example might be four consecutive cards (e.g., 9, 10, J, Q) where the player holds those four cards and elects to draw one card. For each of these types of predetermined criteria, a bonus value such as a multiplier may be associated therewith. If the player's partial hand, however it may be defined, meets any of the predetermined criteria, the multiplier or other bonus function can be applied to any payout of the resulting hand in the manner previously described.

[0099] In accordance with another embodiment and corresponding to the example of FIGS. 11A, 11B and 11C, one or more specific card locations may be designated in advance to delineate the partial hand. Referring to FIG. 11A, a five-card hand 1100 is dealt to the player, and two locations 1102, 1104 are designated as the partial hand cards. Therefore, the cards 1106, 1108 that are dealt to the locations 1102, 1104 represent the starting hand to be compared to the predetermined starting hand criteria. A starting hand payable 1110 is provided, which identifies predetermined starting hand types and corresponding multiplier values. Resulting hand payable 1112 identifies predetermined resulting hands and corresponding payout amounts.

[0100] Referring to FIG. 11B, the player has received a pair of Aces (A,A) as cards 1106, 1108 at locations 1102, 1104. The payable 1110 indicates that the player will therefore be entitled to multiply any payout associated with a resulting hand by "5" as shown at row 1114. In the illustrated example, no starting hand payout is provided (see, e.g., column 212 of FIGS. 2B, 2C, 3A, 3B), although in other embodiments such a starting hand payout may be provided. The player chooses to hold the pair of Aces 1106, 1108 and the pair of Tens 1116, 1118, and opts to discard the Four of Clubs 1120A in an effort to better his/her hand by receiving a replacement/draw card.

[0101] FIG. 11C illustrates a final progression stage of the poker hand, where the Four of Clubs 1120A of FIG. 11B has now been replaced with a new card, which is another Ten 1120B. In the illustrated embodiment, the player has received a Full House (A,A,10,10,10). From the resulting hand payable 1112, it can be seen at row 1122 that a Full House pays "15" units. In accordance with the present invention, the previous multiplier of "5" awarded to the player as a result of the qualifying starting hand at locations 1102, 1104 is multiplied by the "15" units awarded to the player as a result of the player's resulting hand. Thus, the total payout is "15" units times the multiplier of "5" for a total payout of "75" units.

[0102] The present invention is applicable to yet other poker games. FIGS. 12A, 12B and 12C illustrate yet another example, where the present invention is implemented in a blackjack poker game. In one embodiment, the starting hand is the two cards 1200, 1202 initially dealt to the player. A payable 1204 illustrating a starting hand type 1206 and corresponding bonus values 1208 is provided. For example, a pair of Twos or a pair of Threes will provide a multiplier of "2," and a Two/Three combination will provide a multiplier of "3." In blackjack, the resulting hand of the player

must beat the dealer's hand, which generally includes one face up card **1210** and one face down card **1212**. If the player's resulting hand in fact beats the dealer's hand, the player will win an amount commensurate with the player's bet **1213**, which is \$5 in the illustrated embodiment. In accordance with the present invention, that resulting amount may be increased by the bonus value (e.g., multiplier) earlier awarded to the player if the player's initial cards **1200**, **1202** match any of the starting hand types **1206**. In the example of **FIG. 12A**, the player has been awarded a multiplier of "2," because the player's initial cards **1200**, **1202** match a predetermined starting hand type **1206** as shown at row **1214**.

[0103] The progression of this blackjack hand can be seen in **FIG. 12B**. The player has opted to "hit," and received a Ten of Diamonds **1216**, and to hit again to receive a Five of Clubs **1218**. The player stands on a total of "19" ($2+2+10+5$). As seen in **FIG. 12C**, the dealer then turns over the face down card **1212** to expose a Seven, resulting in a total of Seventeen ($10+7$) for the dealer. It is assumed that the dealer must stand on "16," and therefore the player wins the hand. Typically the player would win \$5 to cover his/her \$5 bet **1213**. However, because the player's starting hand **1200**, **1202** resulted in a multiplier of "2," the player's \$5 award is multiplied by "2," resulting in a total payout of \$10.

[0104] As evidenced by the various representative embodiments described herein, the present invention may be implemented in a number of different card playing contexts. In situations where a partial/starting hand may naturally occur, and/or where a partial/starting hand may be devised, the present invention may be implemented such that the partial/starting hand is compared to predetermined criteria, and if a match occurs a bonus value contingent upon a final result may be used to adjust that final result. The invention, however, may be utilized in other gaming activity contexts where a subset(s) of the gaming elements/items otherwise associated with the gaming activity can be devised. For example, traditional slot machine games utilize symbol-bearing mechanical and/or electronic reels to present symbol combinations, where symbol combinations matching predetermined symbol combinations present payouts. The present invention can be integrated into such gaming activities as well, as described in connection with the example of **FIG. 13**.

[0105] **FIG. 13** is a diagram illustrating a representative example in which the present invention may be integrated into a slot game where obtaining certain symbol combinations can provide a payout (hereinafter referred to as "slot games"). A first payable **1300** may be provided to set forth the predetermined partial result criteria to receive the bonus values. The partial result may be devised in any desired fashion, such as the symbols in predetermined locations of the symbol presentation. For example, a mechanical or electronic display **1302** presents various symbol locations, shown at the intersections of rows **1304**, **1306**, **1308**, **1310** and columns **1312**, **1314**, **1316**, **1318**. As is known in the art, the number of rows and columns depends on the particular slot game, the number of reels, the number of paylines, and/or other factors. For example, a three "reel" (electronic or mechanical) slot machine may have one payline, thereby presenting one row and three columns for a total of three "display segments" in which symbols may be presented on a single payline. Other embodiments may include many

reels, many rows, and many paylines. The partial result may be devised from the symbols occurring at predetermined locations of any one or more of these display segments. For example, the display segments **1320**, **1322** may be determined to be the locations at which the symbols presented therein are used to compare against predetermined criteria to determine whether a bonus value may be applied to a final result. Thus, if a symbol combination in display segments **1320**, **1322** match the symbol criteria **1330** of the payable **1300**, a bonus value (e.g., multiplier "MULT") **1334** and optionally a non-contingent payout **1332** may be awarded to the player. It should be noted that any number of predetermined symbol locations may be utilized and in any desired pattern, and the two horizontally placed positions **1320**, **1322** is only an example.

[0106] More particularly, the payable **1300** may include one or more symbol criteria **1330**, such as "2 STARS" in the predetermined locations **1320**, **1322**, or "2 RIBBONS" in the predetermined locations **1320**, **1322**, or any other or different desired criteria. The representative payable **1300** indicates that if "2 STARS" are presented at locations **1320**, **1322**, a bonus value (a multiplier in this instance) of "5" is awarded. Optionally, an automatic payout of "1" unit may also be provided where "2 STARS" are achieved in the predetermined locations **1320**, **1322**. A second payable **1340** is also provided for final results of the slot game, which may be a traditional slot game payable. For example, if the player receives three stars in a row, the player will be awarded with 100 units/credits.

[0107] In the illustrated embodiment, the player has received two STAR symbols in the predetermined locations **1320**, **1322**. In one embodiment, the symbols at the predetermined locations **1320**, **1322** are presented prior to other symbols on the display **1320**; i.e., the other positions continue to spin or otherwise do not yet present a symbol in their respective symbol locations. In another embodiment, only the symbols on the vertical reels associated with the reels of the predetermined locations **1320**, **1322** are presented, while the remaining reels continue to spin. For example, in a mechanical embodiment, each of the columns **1312**, **1314**, **1316**, **1318** may be implemented using respective vertically-spinning reels, where the reels associated with columns **1312** and **1314** are stopped, while any remaining reels continue to spin. An analogous embodiment would be where the reels spin horizontally and the predetermined locations **1320**, **1322** are positioned vertical relative to one another. In another embodiment, all of the symbols may be presented substantially simultaneously, whereby the symbols in the predetermined locations **1320**, **1322** are presented substantially contemporaneously with the final result of the slot game. Alternatively, all of the symbols may be presented substantially simultaneously, but the symbols not associated with the predetermined locations **1320**, **1322** are temporarily hidden, obscured, or otherwise not clearly presented. Any number of different options may be utilized.

[0108] The two STAR symbols in the predetermined locations **1320**, **1322** are compared to the symbol criteria **1330** of payable **1300**. Because "2 STARS" in the predetermined locations **1320**, **1322** matches one of the predetermined symbol criteria **1330**, a PAY **1332** of "1" unit is awarded, and a multiplier (MULT) of "5" is awarded as shown at row **1336**. When all symbol locations (i.e., display segments) have presented their respective symbols (including null or

blank symbols), this final result is compared to the second payable **1340** to determine the standard payout. In the illustrated embodiment, the player has received three STARS in a row at locations **1320**, **1322**, **1342**, which corresponds to an award of "100" units as shown at row **1344**. Because the player had been awarded a multiplier of "5," the total payout will therefore be "500" units, plus the "1" unit awarded from the PAY **1332**, for a total payout of "501" units. In one embodiment, the multiplier is multiplied by the total of all payline winnings. For example, if the player received payouts on four different paylines that totaled "20" units, the multiplier of "5" would result in a total payout of "100" units.

[0109] In one variation of this embodiment, the final result producing a payout that is available for increase by the bonus value (multiplier in this example) must include the predetermined locations **1320**, **1322**. In such an embodiment, three STAR symbols in a row at locations of the display **1302** that do not include at least one or up to all of the predetermined locations **1320**, **1322** will not be subject to a payout increase via the multiplier. In another embodiment, any resulting payout will be increased by an awarded multiplier, regardless of whether the winning symbol combinations include symbols from predetermined locations **1320**, **1322** or not.

[0110] In one embodiment, the predetermined locations (e.g., **1320**, **1322** and/or other predetermined display segments) are not part of the standard play grid of rows **1304**, **1306**, **1308**, **1310** and columns **1312**, **1314**, **1316**, **1318**. Rather, a separate display of symbols, such as one, two or more separate display segments, may be provided independent of such a standard grid. For example, a separate area including two display segments may be provided which spins before the standard grid. The symbols presented in such separate display segments may then be used as the partial result that determines the multiplier or other bonus value. Other embodiments are also within the scope and spirit of the invention.

[0111] The present invention may be implemented in different manners, such as via a live table game or an electronic embodiment. **FIG. 14** illustrates a representative embodiment of a casino-style gaming device in which the principles of the present invention may be applied. For purposes of explanation, the description of the gaming device in **FIG. 14** is provided in terms of a gaming device in the form of a kiosk or slot machine **1400**. However, the present invention is analogously applicable to other computer-based systems.

[0112] The illustrated gaming machine **1400** includes a computing system (not shown) to carry out operations according to the invention. The illustrated gaming machine **1400** includes a display **1402**, and a user interface **1404**, although some or all of the user interface may be provided via the display **1402** in touch screen embodiments. The user interface **1404** allows the user to control and engage in play of the gaming machine **1400**. The particular user interface mechanisms associated with user interface **1404** is dependent on the type of gaming machine. For example, the user interface **1404** may include one or more buttons, switches, joysticks, levers, pull-down handles, trackballs, voice-activated input, or any other user input system or mechanism that allows the user to play the particular gaming activity.

The user interface **1404** may allow the user to enter coins, bills, or otherwise obtain credits through vouchers, tokens, credit cards, tickets, etc. Various mechanisms for entering such vouchers, tokens, credit cards, coins, tickets, etc. are known in the art. For example, coin/token input mechanisms, card readers, credit card readers, smart card readers, punch card readers, and other mechanisms may be used to enter wagers. It is through the user interface **1404** that the user can initiate and engage in a gaming activity in accordance with the invention. While the illustrated embodiment depicts various buttons for the user interface **1404**, it should be recognized that a wide variety of user interface options are available for use in connection with the present invention, including pressing buttons, touching a segment of a touch-screen, entering text, entering voice commands, or other known user entry methodology. The particular user interface mechanism utilized is not relevant to the present invention.

[0113] The display device **1402** may include one or more of an electronic display, a mechanical display, and fixed display information such as information such as payable information associated with a glass/plastic panel on the gaming machine **1400**. The cards or other indicia associated with the play of the game may be presented on an electronic display device.

[0114] Assuming a multi-hand Hold'em embodiment such as described in connection with **FIG. 9**, the player uses the user interface **1404** (including the possibility of touch screen or other interface not specifically shown on interface **1404**) to bet the appropriate number of hands to play such as via the BET # HANDS button **1406**. The player can also select the number of credits to bet via the BET CREDITS button **1408**, or may opt to bet the maximum number of credits by selecting the BET MAX button **1410**. The player receives a starting hand(s). In the embodiment illustrated in **FIG. 14**, the player receives multiple starting hands **1412**, **1414**, and is allowed to select one of the starting hands to play. The user interface (UI) **1404** provides some manner to allow the player to select one of the starting hands **1412**, **1414**, such as the SELECT HAND button **1416** which may toggle between the available starting hands **1412**, **1414**. Alternatively, discrete buttons on the UI **1404** may be provided, one for each available starting hand, or any other selection manner may be utilized.

[0115] Play continues as previously described. Briefly, the selected starting hand can then be compared to a first payable **1420** which includes the predetermined starting hand types and corresponding bonus values, such as payable **900** of **FIG. 9**. If a match is found, the corresponding bonus value(s) such as a multiplier is awarded to the player for use in potentially increasing a final payout. A second payable **1422** (which may be integrated with the first payable **1420**) provides the predetermined resulting hand types and corresponding payout values, such as payable **910** of **FIG. 9**. As seen in **FIG. 14**, the player is concurrently playing three hands, as three "boards" **1424**, **1426**, **1428** are displayed. The player's selected starting hand and the cards of each of the respective boards **1424**, **1426**, **1428** are used to create three resulting hands. Any resulting hand(s) matching the predetermined resulting hand criteria of payable **1422** will be awarded a payout, which can be increased using an awarded bonus value (if any) from payable **1420**.

[0116] A display segment or panel **1430** may also be provided to display information such as the accumulated credits, current bet amount such as “10” credits (where credits may represent, for example, coins, tokens, dollars, etc.), the number of concurrent hands played, total bet, the number of credits paid out on a particular play, etc. A wager acceptor **1432** is operative to receive wager tokens, coins, bills, credit/debit cards, coupons, smart cards, prepaid casino cards, electronic fund transfer (EFT), tickets, and the like.

[0117] As may now be readily understood, the device **1400** may be programmed to play various embodiments of the invention. The present invention may be implemented as a casino gaming machine such as a slot machine or other special purpose gaming kiosk as described in **FIG. 14**, or may be implemented via computing systems operating under the direction of local gaming software, and/or remotely-provided software such as provided by an application service provider (ASP). The casino gaming machines utilize computing systems to control and manage the gaming activity. An example of a representative computing system capable of carrying out operations in accordance with the invention is illustrated in **FIG. 15**.

[0118] Hardware, firmware, software or a combination thereof may be used to perform the various gaming functions, display presentations and operations described herein. The functional modules used in connection with the invention may reside in a gaming machine as described, or may alternatively reside on a stand-alone or networked computer. The computing structure **1500** of **FIG. 15** is an example computing structure that can be used in connection with such electronic gaming machines, computers, or other computer-implemented devices to carry out operations of the present invention.

[0119] The example computing arrangement **1500** suitable for performing the gaming functions in accordance with the present invention typically includes a central processor (CPU) **1502** coupled to random access memory (RAM) **1504** and some variation of read-only memory (ROM) **1506**. The ROM **1506** may also represent other types of storage media to store programs, such as programmable ROM (PROM), erasable PROM (EPROM), etc. The processor **1502** may communicate with other internal and external components through input/output (I/O) circuitry **1508** and bussing **1510**, to provide control signals, communication signals, and the like.

[0120] Chance-based gaming systems such as slot machines, in which the present invention is applicable, are governed by random numbers and processors. A display device **1511** is used to display the gaming activity as facilitated by a random number generator (RNG). RNGs are well-known in the art, and may be implemented using hardware, software operable in connection with the processor **1502**, or some combination of hardware and software. The present invention is operable using any known RNG, and may be integrally programmed as part of the processor **1502** operation, or alternatively may be a separate RNG controller **1540**.

[0121] The computing arrangement **1500** may also include one or more data storage devices, including hard and floppy disk drives **1512**, CD-ROM drives **1514**, and other hardware capable of reading and/or storing information such as DVD, etc. In one embodiment, software for carrying out the

operations in accordance with the present invention may be stored and distributed on a CD-ROM **1516**, diskette **1518** or other form of media capable of portably storing information. These storage media may be inserted into, and read by, devices such as the CD-ROM drive **1514**, the disk drive **1512**, etc. The software may also be transmitted to the computing arrangement **1500** via data signals, such as being downloaded electronically via a network, such as the Internet. Further, as previously described, the software for carrying out the functions associated with the present invention may alternatively be stored in internal memory/storage of the computing device **1500**, such as in the ROM **1506**.

[0122] The computing arrangement **1500** is coupled to the display **1511**, which represents a display on which the gaming activities in accordance with the invention are presented. The display **1511** may be any type of known display or presentation screen, such as LCD displays, plasma display, cathode ray tubes (CRT), etc. Where the computing device **1500** represents a stand-alone or networked computer, the display **1511** may represent a standard computer terminal or display capable of displaying multiple windows, frames, etc. Where the computing device is embedded within an electronic gaming machine (see **FIG. 14**), the display **1511** corresponds to the display screen of the gaming machine/kiosk. A user input interface **1522** such as a mouse, keyboard/keypad, microphone, touch pad, trackball, joystick, touch screen, voice-recognition system, etc. may be provided.

[0123] The computing arrangement **1500** may be connected to other computing devices or gaming machines, such as via a network. The computing arrangement **1500** may be connected to a network server **1528** in an intranet or local network configuration. The computer may further be part of a larger network configuration as in a global area network (GAN) such as the Internet. In such a case, the computer accesses one or more web servers **1530** via the Internet **1532**.

[0124] Other components directed to gaming machine implementations include manners of gaming participant payment, and gaming machine payout. For example, a gaming machine including the computing arrangement **1500** may also include a hopper controller **1542** to determine the amount of payout to be provided to the participant. The hopper controller may be integrally implemented with the processor **1502**, or alternatively as a separate hopper controller **1542**. A hopper **1544** may also be provided in gaming machine embodiments, where the hopper serves as the mechanism holding the coins/tokens of the machine. The wager input module **1546** represents any mechanism for accepting coins, tokens, coupons, bills, electronic fund transfer (EFT), tickets, credit cards, smart cards, membership cards, etc., for which a participant inputs a wager amount.

[0125] In addition to electronic embodiments, embodiments of the present invention may be played in a live table version. An example table layout **1600** is illustrated in **FIG. 16** for use as a gaming table cover or top surface in playing live casino versions of poker games employing the invention. For purposes of illustration and not of limitation, **FIG. 16** is described in the context of a Hold'em poker game in accordance with the present invention.

[0126] The embodiment of **FIG. 16** includes a plurality of player locations **1602**, **1604**, **1606**, **1608**, **1610** spaced

around a periphery at which one or more players will situate themselves during play of the game. A dealer **1612** may deal one or more starting hands **1613**, **1614**, **1616**, **1618**, **1620** to each of the players. Using the starting hand payable **1625**, it can be determined whether each player receives a multiplier, or optionally other bonus amounts such as fixed pay amounts. Each player places a bet, and in multi-hand embodiments, may designate which of a plurality of community hands are to be played. For example, Player-A **1602** has placed an identifier on each of the hand designators **1**, **2**, **3**, which indicates that three hands will be concurrently played using each of the community card boards **1642**, **1644**, **1646**. Player-B **1604**, on the other hand, has identified only community card board **1644** by identifying the board **1644** labeled "2."

[0127] When each player has arrived at his/her resulting hand(s), the payable **1630** is used to determine a payout, and if the player was previously awarded a multiplier, then that multiplier is applied to any winning payouts based on the resulting hand. Different payouts may be provided for different wagered amounts. In other embodiments, the players may be playing against each others' hands rather than using the payable **1630**. In such an embodiment, the house is funded in some predetermined manner, so that the house can pay increased winnings due to the multipliers. In other embodiments such as the embodiment illustrated in **FIG. 16**, play is against the house, and wagering transactions occur only between each player and the house. Other variations are also within the scope and spirit of the invention.

[0128] As seen from the foregoing representative embodiments, the present invention provides a manner of introducing bonus or otherwise additional payout awards into gaming activities. In various forms, the invention utilizes a subset(s) of the gaming elements/items otherwise associated with the gaming activity to determine whether a conditional payout increase, contingent upon a final result of the gaming activity, will be awarded. A number of these various gaming activity methodologies in accordance with the present invention are summarized below.

[0129] **FIG. 17** is a flow diagram directed to a general embodiment of the present invention. In the illustrated embodiment, a bonus value is awarded **1700** based on a partial result of a gaming activity, if the partial result corresponds to a predetermined partial result(s). The bonus value may be a multiplier as described above, or may be another value impacting a final result payout award. For example, different mathematical functions may similarly be used, and/or combinations of mathematical functions. As a more particular example, the bonus value could be an exponent to the final payout result. If the bonus value was a "3," and the final payout was "4" units, then $4^3=64$ units. The bonus value may be contingently applied to any final payout value.

[0130] The gaming activity is completed **1702** to provide a complete result. In a poker embodiment, this typically involves completing the hand to the point that the player has received all of the cards from which to create the resulting hand. A payout is determined **1704** for the complete result. If the partial result matched any of the predetermined results as determined at decision block **1706**, then the payout for the complete result is adjusted **1708** accordingly, using the awarded bonus value.

[0131] One particularly interesting embodiment of the invention is in the context of Hold'em poker games, as previously described. **FIG. 18** is a flow diagram illustrating a community hand poker method (e.g., Hold'em poker or other community card game) implementing the principles of the present invention. In the illustrated embodiment, a bonus value such as a multiplier, exponent, or other function is awarded **1800** based on the player's starting hand, if the starting hand corresponds to any of a set of one or more predetermined starting hands. One or more resulting hands are derived **1802** from a set of cards including the starting hand and a community hand(s). A payout for the resulting hand(s) is determined **1804**, and if the starting hand matched any of the predetermined starting hands as determined at decision block **1806**, the payout is adjusted **1808** for the resulting hand(s) using the awarded bonus value.

[0132] **FIG. 19** is a flow diagram illustrating one particular embodiment of a Hold'em embodiment of the invention. A first payable of predetermined hole cards and corresponding multipliers is provided **1900**. If payouts are also desired for particular starting hand combinations, they may be included **1902** in the first payable. A second payable of predetermined final hands and corresponding payouts is also provided **1904**. If the game does include the option for the player to select from a plurality of starting hands as determined at decision block **1906**, then the hole cards are dealt **1908** without such selection. Otherwise, multiple sets of hole cards are dealt **1910**, and the player selects **1912** a set of hole cards from the plurality of sets of selectable hole cards.

[0133] Based on the player's hole cards, it is determined **1914** whether a multiplier is awarded to the player. This may be determined by comparing the player's hole cards to the set of predetermined hole cards in the first payable, and if a match is found, identifying the corresponding multiplier for that particular hole card combination.

[0134] The game may be a single-hand game or a multiple-hand game. If the game is not a multi-hand game as determined at decision block **1916**, the board cards are dealt or otherwise exposed as shown at block **1918**, and a resulting hand is derived **1920** from a combination of the hole cards and the cards of the board. If it is a multi-hand game, one set of board cards is dealt/exposed **1922** for each concurrent game being played. For example, if three games are concurrently played, then three boards are dealt or otherwise exposed. A resulting hand is derived **1924** for each combination of the hole cards and the plurality of boards. If no payout results from any of the resulting hands as determined at decision blocks **1926**, **1928** then no payout **1929** is provided and any awarded multiplier has no effect. An exception is the case where payouts are awarded based on the player's hole cards, in which case the player may receive some known payout based on the hole cards that match the predetermined hole cards in the first payable.

[0135] If a payout results in either the single-hand or multi-hand embodiments, the multiplier will be applied to the resulting payouts if a multiplier was awarded at block **1914**. More particularly, if the hole cards did not match any of the predetermined hole cards in the first payable as illustrated at decision block **1930**, then no multiplier is applied as shown at block **1932**, and any payout from the resulting hand is awarded **1934**. If any of the hole cards

matched any of the predetermined hold cards in the first payable as illustrated at decision block **1930**, then the resulting payout, or potentially multiple payouts in a multi-hand embodiment, are increased using the multiplier as shown at block **1936**. The increased payout can then be awarded **1934** to the player.

[**0136**] As previously indicated, the invention may be integrated with a variety of different known gaming activities where a subset(s) of the gaming elements is already available or can be devised. **FIG. 20** is a flow diagram illustrating a draw poker game incorporating the present invention as was previously described in connection with **FIGS. 11A, 11B, 11C**. A bonus value such as a multiplier is awarded **2000** based on a partial hand(s) of one or more cards in a predetermined location(s) of a draw poker game, if the partial hand corresponds to any predetermined partial hands. As shown at block **2002**, the player may discard and draw cards if desired to arrive at a resulting hand, or multiple resulting hands if multiple hands are being played. The payout is determined **2004** for any resulting hands, and if the partial hand matched any of the predetermined partial hands as determined at decision block **2006**, the payout is adjusted **2008** using the awarded bonus value.

[**0137**] **FIG. 21** is a flow diagram illustrating yet another embodiment in a slot game context, such as the embodiment described in connection with **FIG. 13**. A bonus value may be awarded **2100** based on a first group of one or more symbols being presented at particular locations of the slot game, if the first group of symbols corresponds to a predetermined symbol combination. The particular locations may be determined in advance, or may change but with highlighting or other delineations to identify which locations are relevant for comparison to the predetermined symbol combinations. Some or all of the remaining reel locations are then presented **2102**, and a payout is determined **2104** for active paylines. If the first group of symbols matches any of the predetermined symbol combinations as determined at decision block **2106**, then any payout received as a result of the resulting active paylines is adjusted **2108** using the bonus value.

[**0138**] The foregoing description of the exemplary embodiment of the invention has been presented for the purposes of illustration and description. It is not intended to be exhaustive or to limit the invention to the precise form disclosed. Many modifications and variations are possible in light of the above teaching. For example, the present invention is equally applicable in electronic or mechanical gaming machines, and is also applicable to live table versions of the gaming activities. It is intended that the scope of the invention be limited not with this detailed description, but rather determined from the claims appended hereto.

What is claimed is:

1. A method for facilitating play of a gaming activity, comprising:

awarding a bonus value based on a partial result of the gaming activity, if the partial result corresponds to any of one or more predetermined partial results;

completing the gaming activity to provide a complete result;

determining a payout for the complete result; and

if the partial result corresponds to any of the one or more predetermined partial results, adjusting the payout for the complete result using the awarded bonus value to provide a final payout.

2. The method of claim 1, wherein awarding a bonus value comprises awarding a value to be mathematically applied to the payout to arrive at the final payout.

3. The method of claim 2, wherein awarding a value comprises awarding an integer value to be multiplied to the payout to arrive at the final payout.

4. The method of claim 1, wherein awarding a bonus value comprises awarding a multiplier value based on the partial result of the gaming activity, if the partial result corresponds to any of the one or more predetermined partial results.

5. The method of claim 1, wherein adjusting the payout comprises increasing the payout by a mathematical function of the bonus value.

6. The method of claim 5, wherein increasing the payout by a mathematical function of the bonus value comprises increasing the payout proportionately using the bonus value.

7. The method of claim 5, wherein increasing the payout by a mathematical function of the bonus value comprises increasing the payout exponentially using the bonus value.

8. The method of claim 1, further comprising disregarding an adjustment to the payout if the partial result does not correspond to any of the one or more predetermined partial results.

9. The method of claim 1, if the partial result corresponds to any of the one or more predetermined partial results and if no payout is available for the complete result, further comprising providing a fixed bonus payout identified by the predetermined partial result that corresponds to the partial result of the gaming activity.

10. The method of claim 1, if the partial result corresponds to any of the one or more predetermined partial results and if the payout available for the complete result is less than a fixed bonus payout identified by the predetermined partial result that corresponds to the partial result of the gaming activity, further comprising providing as the final payout the fixed bonus payout identified by the predetermined partial result that corresponds to the partial result.

11. The method of claim 1, further comprising facilitating user selection of the partial result from a plurality of possible partial results.

12. The method of claim 1, wherein determining a payout for the complete result comprises:

correlating one or more predetermined complete results with respective payout amounts;

comparing the complete result of the gaming activity to the one or more predetermined complete results; and

if the complete result matches any of the predetermined complete results, identifying the payout amount corresponding to the predetermined complete result that matches the complete result.

13. The method of claim 1, wherein:

the gaming activity comprises a poker game;

the partial result of the poker game comprises a first set of cards, and the one or more predetermined partial results comprise one or more predetermined sets of cards;

completing the poker game to provide a complete result comprises deriving a resulting hand from a set of cards including the first set of cards and a second set of cards;

determining a payout for the complete result comprises comparing the resulting hand to a payable to determine the payout, if any, that corresponds to the resulting hand; and

adjusting the payout comprises adjusting the payout for the resulting hand using the awarded bonus value if the first set of cards corresponds to any of the one or more predetermined sets of cards.

14. The method of claim 13, wherein:

the first set of cards comprises a two-card starting hand; the second set of cards comprises a five-card community hand; and

deriving a resulting hand comprises deriving a five-card resulting hand from the set of cards including the two-card starting hand and the five-card community hand.

15. The method of claim 13, wherein the first set of cards comprises one or more cards.

16. The method of claim 13, wherein the second set of cards comprises one or more cards.

17. The method of claim 13, wherein the second set of cards comprises one or more community cards.

18. A method for facilitating play of a poker game, wherein resulting hand payout awards are provided for particular resulting hands, the method comprising:

correlating one or more particular starting hands with one or more bonus values;

providing at least one starting hand to each of one or more players participating in the poker game;

determining whether the at least one starting hand of each player matches any of the one or more particular starting hands, and if so, reserving the bonus value corresponding to the matching particular starting hand for use in determining the respective player's total payout award;

creating at least one resulting hand for each of the players;

determining whether the at least one resulting hand of each player matches any of the particular resulting hands, and if so, awarding the corresponding resulting hand payout award; and

increasing the resulting hand payout award to arrive at the player's total payout award by increasing the player's total payout award as a function of the respective reserved bonus value.

19. The method of claim 18, wherein each player's starting hand is available for use in creating the respective player's resulting hand.

20. The method of claim 18, wherein creating at least one resulting hand for each of the players comprises creating the at least one resulting hand for each of the players using at least one of the cards of the respective player's starting hands and at least one community card.

21. The method of claim 18, wherein creating at least one resulting hand for each of the players comprises creating the at least one resulting hand for each of the players using a

subset of cards of a set of cards including the respective player's starting hand and one or more additional cards.

22. The method of claim 21, wherein creating the at least one resulting hand for each of the players using a subset of cards of a set of cards including the respective player's starting hand and one or more additional cards comprises creating the at least one resulting hand for each of the players using a subset of cards of a set of cards including the respective player's starting hand and one or more community cards available to each of the one or more players.

23. The method of claim 18, further comprising creating the resulting hand for each player that had not folded prior to receiving additional cards used in the creation of the resulting hand.

24. A method for facilitating play of a poker game, comprising:

providing a first payable of one or more designated starting hands of cards representing a subset of a set of available starting hands of cards;

associating a multiplier with at least some of the designated starting hands;

providing a player starting hand of cards to a participant of the poker game;

comparing the player starting hand to the one or more designated starting hands, and identifying the associated multiplier if the player starting hand corresponds to any of the designated starting hands;

providing one or more additional cards for use with the player starting hand to create one or more player resulting hands;

providing a second payable of a plurality of designated resulting hands and associated payout values;

comparing the one or more player resulting hands to the plurality of designated resulting hands, and identifying the associated payout value of the one or more player resulting hands that correspond to any of the designated resulting hands; and

calculating a total payout value for each of the player resulting hands by multiplying the identified associated multiplier and the identified associated payout values of each of the player resulting hands.

25. The method of claim 24, wherein providing one or more additional cards comprises providing a plurality of sets of the one or more additional cards, and wherein each of the plurality of sets is separately used with the player starting hand to create a corresponding plurality of the player resulting hands.

26. A method for facilitating play of a poker game, comprising:

providing a first payable of one or more designated starting hands of cards representing a subset of a set of available starting hands of cards;

associating a multiplier with each of the designated starting hands;

providing a player starting hand of cards to a participant of the poker game;

comparing the player starting hand to the one or more designated starting hands, and identifying the associ-

ated multiplier if the player starting hand corresponds to any of the designated starting hands;

providing one or more additional cards for use with the player starting hand to create a player resulting hand;

providing a second payable of a plurality of designated resulting hands and associated payout values;

comparing the player resulting hand to the plurality of designated resulting hands, and identifying the associated payout value of the player resulting hand if it corresponds to any of the designated resulting hands; and

if an associated multiplier has been identified by way of the player starting hand corresponding to any of the designated starting hands, calculating a total payout value by multiplying the identified multiplier and the identified payout value.

27. The method of claim 26, wherein associating a multiplier with each of the designated starting hands comprises associating a different multiplier with each of the designated starting hands.

28. The method of claim 26, wherein associating a multiplier with each of the designated starting hands comprises associating a common multiplier with at least some of the designated starting hands, and associating different multipliers with at least some of the remaining designated starting hands.

29. A method for facilitating play of a video Hold'em poker game by a participant, comprising:

providing a first payable of designated hole card combinations;

associating a multiplier with each of the designated hole card combinations;

providing a player starting hand including player hole cards to the participant;

comparing the player hole cards to the designated hole card combinations, and identifying the associated multiplier if the player hole cards match any of the designated hole card combinations;

providing at least one set of one or more additional cards for use with the player starting hand to create a player resulting hand;

providing a second payable of a plurality of designated resulting hands and associated payout values;

comparing the player resulting hand to the plurality of designated resulting hands, and identifying the associated payout value of the player resulting hand if it corresponds to any of the designated resulting hands; and

if a multiplier has been identified due to the player hole cards matching any of the designated hole card combinations, calculating a total payout value by multiplying the multiplier and the identified payout value.

30. The method of claim 29, further comprising presenting a plurality of selectable player starting hands and facilitating participant selection of one of the selectable player starting hands, and wherein the selected player starting hand represents the player starting hand.

31. The method of claim 29, wherein providing at least one set of one or more additional cards comprises providing a multiple-card community hand.

32. The method of claim 29, wherein providing at least one set of one or more additional cards comprises providing a plurality of community hands, and wherein a player resulting hand is created from each combination of the player starting hand and the respective community hands.

33. The method of claim 29, further comprising associating an initial payout with each of the designated hole card combinations.

34. The method of claim 33, wherein the initial payout is dependent on a participant wager amount and increases as the participant wager amount increases.

35. The method of claim 33, wherein the initial payout is dependent on a participant wager amount and increases proportionately to an increase in the participant wager amount.

36. The method of claim 33, wherein at least one of the initial payouts provide a positive initial payout award, and at least one of the initial payouts provide zero payout award.

37. The method of claim 33, wherein the initial payout is awarded to the participant only if the payout value identified for the resulting hand is less than an amount of the initial payout.

38. The method of claim 33, wherein the initial payout is awarded to the participant only if the payout value identified for the resulting hand is zero.

39. A computer-implemented gaming apparatus for allowing player participation in an electronic gaming activity, the gaming apparatus comprising:

a display;

a first payable identifying one or more predetermined partial results and corresponding bonus values for each of the predetermined partial results;

a second payable identifying one or more predetermined complete results and corresponding resulting payouts for each of the predetermined complete results;

a processor configured to direct the display to present at least one partial result of the electronic gaming activity to the player and award a bonus value based on the partial result if the partial result matches any of the predetermined partial results of the first payable, to complete the gaming activity to provide a complete result and determine a payout for the complete result, and to adjust the payout for the complete result using the awarded bonus value to provide a final payout if a bonus value was awarded.

40. A computer-implemented poker apparatus for allowing player participation in an electronic poker game, the poker apparatus comprising:

a display;

a first payable identifying one or more predetermined partial hands and corresponding bonus values for each of the predetermined partial hands;

a second payable identifying one or more predetermined resulting hands and corresponding resulting payouts for each of the predetermined resulting hands;

a processor configured to direct the display to present at least one partial hand of the electronic poker game to

the player and award a bonus value based on the partial hand if the partial hand matches any of the predetermined partial hands of the first payable, to direct the display to present one or more additional cards available for combination with the partial hand to arrive at a resulting hand; to determine a resulting payout for the resulting hand if the resulting hand matches any of the predetermined resulting hands of the second payable, and to adjust the resulting payout for the resulting hand using the awarded bonus value to provide a final payout if the partial hand matched any of the predetermined partial hands of the first payable.

41. The computer-implemented poker apparatus as in claim 40, wherein the processor is configured to direct the display to present a plurality of the partial hands, and further comprising a user interface to facilitate player selection of at least one of the partial hands.

42. The computer-implemented poker apparatus as in claim 40, wherein the bonus values comprise multiplier values, and wherein the first payable comprises a list of the predetermined partial hands and their corresponding ones of the multipliers.

43. The computer-implemented poker apparatus as in claim 42, wherein the bonus values further comprise fixed payout values payable to the player if the resulting hand does not match any of the predetermined resulting hands of the second payable.

44. The computer-implemented poker apparatus as in claim 42, wherein the bonus values further comprise fixed payout values payable to the player if the resulting hand provides a resulting payout that is less than the fixed payout value.

45. A computer-readable medium having instructions stored thereon which are executable by a computer system for facilitating play of a gaming activity by performing steps comprising:

awarding a bonus value based on a partial result of the gaming activity, if the partial result corresponds to any of one or more predetermined partial results;

completing the gaming activity to provide a complete result;

determining a payout for the complete result; and

if the partial result corresponds to any of the one or more predetermined partial results, adjusting the payout for the complete result using the awarded bonus value to provide a final payout.

46. A computer-readable medium having instructions stored thereon which are executable by a computer system for facilitating play of a Hold'em poker game by performing steps comprising:

providing a first payable of designated hole card combinations;

associating a multiplier with each of the designated hole card combinations;

providing a player starting hand including player hole cards to the participant;

comparing the player hole cards to the designated hole card combinations, and identifying the associated multiplier if the player hole cards match any of the designated hole card combinations;

providing at least one set of one or more additional cards for use with the player starting hand to create a player resulting hand;

providing a second payable of a plurality of designated resulting hands and associated payout values;

comparing the player resulting hand to the plurality of designated resulting hands, and identifying the associated payout value of the player resulting hand if it corresponds to any of the designated resulting hands; and

calculating a total payout value by multiplying the multiplier and the identified payout value, if a multiplier has been identified due to the player hole cards matching any of the designated hole card combinations.

47. A gaming system for facilitating play of a gaming activity, comprising:

means for awarding a bonus value based on a partial result of the gaming activity, if the partial result corresponds to any of one or more predetermined partial results;

means for completing the gaming activity to provide a complete result;

means for determining a payout for the complete result; and

means for adjusting the payout for the complete result using the awarded bonus value to provide a final payout if the partial result corresponds to any of the one or more predetermined partial results.

48. A gaming system for facilitating play of a Hold'em poker game by at least one participant, comprising:

means for informing the participant of a first payable of designated hole card combinations and associated multipliers;

means for presenting a player starting hand including player hole cards to the participant;

means for comparing the player hole cards to the designated hole card combinations, and for identifying the associated multiplier if the player hole cards match any of the designated hole card combinations;

means for presenting at least one set of one or more additional cards for use with the player starting hand to create a player resulting hand;

means for informing the participant of a second payable of a plurality of designated resulting hands and associated payout values;

means for comparing the player resulting hand to the plurality of designated resulting hands, and for identifying the associated payout value of the player resulting hand if it corresponds to any of the designated resulting hands; and

means for calculating a total payout value by multiplying the multiplier and the identified payout value, if a multiplier has been identified due to the player hole cards matching any of the designated hole card combinations.