

(19) World Intellectual Property Organization
International Bureau



(43) International Publication Date
13 September 2001 (13.09.2001)

PCT

(10) International Publication Number
WO 01/67813 A1

- (51) International Patent Classification⁷: H04R 25/02, 9/00, 9/02
- (21) International Application Number: PCT/SE01/00484
- (22) International Filing Date: 7 March 2001 (07.03.2001)
- (25) Filing Language: Swedish
- (26) Publication Language: English
- (30) Priority Data:
0000810-2 9 March 2000 (09.03.2000) SE
- (71) Applicant (for all designated States except US): OSSEO-FON AB [SE/SE]; Splintvedsgatan 7, S-416 80 Göteborg (SE).
- (72) Inventor; and
- (75) Inventor/Applicant (for US only): HÅKANSSON, Bo [SE/SE]; Splintvedsgatan 7, S-416 80 Göteborg (SE).
- (74) Agent: GÖTEBORGS PATENTBYRÅ DAHLS AB; Sjöporten 4, S-417 64 Göteborg (SE).
- (81) Designated States (national): AE, AG, AL, AM, AT, AT (utility model), AU, AZ, BA, BB, BG, BR, BY, BZ, CA, CH, CN, CO, CR, CU, CZ, CZ (utility model), DE, DE (utility model), DK, DK (utility model), DM, DZ, EE, EE (utility model), ES, FI, FI (utility model), GB, GD, GE, GH, GM, HR, HU, ID, IL, IN, IS, JP, KE, KG, KP, KR, KZ, LC, LK, LR, LS, LT, LU, LV, MA, MD, MG, MK, MN, MW, MX, MZ, NO, NZ, PL, PT, RO, RU, SD, SE, SG, SI, SK, SK (utility model), SL, TJ, TM, TR, TT, TZ, UA, UG, US, UZ, VN, YU, ZA, ZW.
- (84) Designated States (regional): ARIPO patent (GH, GM, KE, LS, MW, MZ, SD, SL, SZ, TZ, UG, ZW), Eurasian patent (AM, AZ, BY, KG, KZ, MD, RU, TJ, TM), European patent (AT, BE, CH, CY, DE, DK, ES, FI, FR, GB, GR, IE, IT, LU, MC, NL, PT, SE, TR), OAPI patent (BF, BJ, CF, CG, CI, CM, GA, GN, GW, ML, MR, NE, SN, TD, TG).
- Published:
— with international search report
- For two-letter codes and other abbreviations, refer to the "Guidance Notes on Codes and Abbreviations" appearing at the beginning of each regular issue of the PCT Gazette.

(54) Title: ELECTROMAGNETIC VIBRATOR

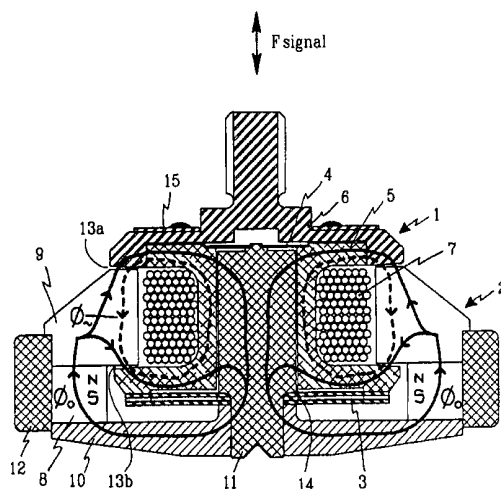

(57) Abstract: The present invention relates to an electromagnetic vibrator of variable reluctance type, according to a new principle which provides higher efficiency, smaller dimension, and higher reliability compared to known technology. This has been obtained by the magnetic signal flux around the coil is closed through a bobbin body and a yoke and through air gaps formed between bobbin body and yoke(s) where a static flux from one or more of the permanent magnets and the signal flux cooperates so that static forces are outbalanced and so that axial signal forces are generated. The new vibrator principle has been named: Balanced Electromagnetic Separation Transducer (BEST).



WO 01/67813 A1

TITLE**ELECTROMAGNETIC VIBRATOR****DESCRIPTION****Technical field**

5 The present invention relates to a bone transmitting hearing aid/bone transmitting vibrator for generating or monitoring vibrations in accordance with the variable reluctance principle comprising a coil for generating/monitoring a magnetic signal flux, a bobbin body of a magnetic conductive material, one or more yokes of magnetic conductive material, and one or more permanent magnets for generating a magnetic biasing flux.

10

Background of the invention

Bone transmitting hearing aids are used by patients who can not use conventional air transmitting hearing aids e.g., due to chronic middle ear disease or a congenital/acquired deformity. A traditional bone transmitting hearing aid consists of a bone transmitting vibrator enclosed in a polymer shell which is pressed with a constant pressure of 3-5 Newton against the skin over the bone behind the ear. Microphone, amplifier, and current source are placed in their own enclosure at a suitable site and at a secure distance from the vibrator to avoid feedback coupling problems. The most essential drawbacks of this type of bone transmitting hearing aids is that it is uncomfortable to wear due to the constant pressure and that the soft skin over the bone deteriorate the transmission of vibrations to the bone.

Since the beginning of the 1980's there is a new type bone transmitting device - a bone anchored hearing aid (BAHA) - where the bone transmitting vibrator is connected directly to the bone via a skin penetrating and bone anchored implant of titanium, cf e.g., SE-A- 81 07 161-5, SE-A- 94 04 188-6 or Tjellström & Håkansson, The Bone Anchored Hearing Aid - Design principles, indications, and long-term clinical results, Otolaryngol. Clin. N. Am. Vol. 28, No. 1, (1995). In this way a bone transmitting hearing aid is obtained which provides for higher amplification, splendid carrying comfort, and where all parts can be enclosed in the same housing. In a future solution the vibrator can be implanted completely and thereby skin and soft tissue can remain intact. Signal and necessary energy can in this case be transferred

30

through intact skin by means of inductive connection. At more severe hearing damages where the energy demand is large the energy can be transferred by means of skin penetrating (percutaneous) electric connection device, cf e.g., SE 9704752-6. The advantages implanting the whole vibrator into the temporal bone compared with a vibrator being externally situated
5 is, besides the pure medical ones, that an increased sensitivity is obtained, the size of the externally placed unit becomes smaller and stability margins becomes improved.

It is of course of utmost importance that BAHA vibrators in general and implantable ones in particular are (1) efficient, to keep current consumption down, (2) small, in order to be able to
10 be placed in the temporal bone, and (3) reliable, as a repair/exchange of the vibrator requires a surgical incision. The need to improve conventional bone transmitting hearing aids in the above mentioned respects is perhaps the most important motif behind the present invention.

Another area of application where the bone transmitting vibrator is used is within clinical
15 audiometry. At a conventional audiometry examination both air transmitting and bone transmitting threshold values are regularly determined. The vibrator used at bone transmitting audiometry is of the same kind as used for bone transmitting hearing aids with the difference that the audiometry vibrator shall be capable of determining bone thresholds down to 250 Hz. It is commonly known the vibrators of today to be used in audiometry, e.g., B71 from Radio
20 Ear, shows dissatisfactory high distortion at low frequencies due to an intrinsic problem of this construction. Thus even here there is a great demand for improving the technology.

Vibrators based on piezo electricity, magnetostriction (magnetic elongation), and electromagnetism of the moving coil type are not used in bone transmitting hearing aids or
25 audiometry vibrators mainly due to bad response at low frequencies. The devices used are electromagnetic vibrators of the variable reluctance type.

Prior art

A cross-section of a conventional (State of the Art) vibrator of variable reluctance type of hitherto known type is shown in Fig. 1. The vibrator of figure 1 is substantially circularly symmetric. It consists of on one hand an annular permanent magnet, a coil coiled around an annular bobbin body, as well, and a counter mass connected in a suitable manner to a rigid unit (lower part), and on the other hand of a vibrator plate connected with a spring element and a suitable adapter for connection to the load (top part). The bobbin body and the vibrator plate are made of magnetic field well conductive material, suitably special treated soft iron. The vibrator plate functions as a yoke closing both the static (biasing) magnetic flux Φ_0 generated by the permanent magnet and the signal flux Φ_s generated by a signal current flowing through the coil. The total development of force in the air gap is determined under certain presumptions approximatively by

$$F_{tot} \propto (\Phi_0 + \Phi_s)^2 = \Phi_0^2 + 2 \cdot \Phi_s \cdot \Phi_0 + \Phi_s^2 \quad \text{Equ. 1}$$

15

The term Φ_0^2 represents the static force of the permanent magnet, the term $2 \cdot \Phi_s \cdot \Phi_0$ represents the useful signal flux and the term Φ_s^2 represents a non-desired distortion. The primary task of the counter mass is to add mass to obtain a suitable resonance frequency f_r according to the relation

$$f_r \propto 1 / \sqrt{m \cdot c} \quad \text{Hz} \quad \text{Equ. 2}$$

Wherein m is the mass of the lower part of the vibrator (including the outer rigid part of the spring element) and c is the compliance (resilience) of the spring element. In the following the mass m is called the counter holding unit. The resonance frequency may, e.g., in accordance with Equ. 2 be lowered by increasing the weight of the counter holding unit (m) or increasing the compliance of the spring element (c).

25

Drawbacks at conventional variable reluctance vibrator

Of the above description it is evident that a conventional variable reluctance vibrator is construed in such a way that the magnetic signal flux coincides/follows the static flux (biasing flux) along its entire run, cf figure 1. It leads to the fact that the properties of the electrodynamic change deteriorate as permanent magnets as a rule have a low relative

30

permeability μ (low permeability provides for a high magnetic flux resistance, which decreases the generation of signal force).

In order to prevent that the air gap which is created between the vibrator plate and the lower
5 part of the vibrator does not collapse due to the static force ($\mu\Phi_0^2$) a spring element is
required that keeps the parts apart. This spring element consists normally of a plate spring
package with or without dampening coating as described in SE-A- 85 02426-3. In resting
condition which corresponds to an air gap of 50 to 100 nm the spring is so bent out to such a
degree that its returning force exactly balances the attracting force of the permanent magnet.
10 The Attraction force of the permanent magnet thus all the time strives to reduce the air gap
created by balancing the magnet force and the spring force. Ageing of the spring as well as
outer mechanical strains may thus lead to that the air gap of the vibrator collapses. If this
should occur the sound of the vibrator becomes strongly distorted and the vibrator has to be
repaired.

15

Another problem is that this type of vibrator, at higher signal levels, creates a high harmonic
distortion of the second order due to the term Φ_0^2 , cf Equ. 1. In order to obtain a good linearity
a high biasing flux (Φ_0) is required, which requires high stiffness of the returning spring
which in turn leads to a higher resonance frequency. This increase of the resonance frequency
20 can be counteracted by increasing the counter holding mass (cf Equ 2) but at the price of
increased weight and size.

Balanced armature

In order both to be able to maintain a high biasing flux and simultaneously to use a softer
25 returning spring one has, since long, used a so called Abalanced armature@-principle , cf e.g.,
US-A-3,491,435 by Elmer V. Carlsson when constructing small loud speakers for placement
in the auditory meatus (generation of air spread sound). The thin arm (Aarmature reed”)of soft
iron material which also functions as returning spring, is placed between two permanent
magnets. In the middle position the magnets draw equally much and the arm is situated in a
30 balanced position. The demand on the spring constant of the returning spring will hereby
become much smaller than if a magnet circuit of the traditional type was to be used. These

transducers are adapted to drive a light weight membrane for air borne creation of sound and the construction can not be transferred to a bone transmitting vibrator the load and working conditions (i.e. the skull bone) differ considerably from air. Further, the signal flux is hereby not only lead through the soft iron material and the air gap but also through the permanent
5 magnet material which as a rule possesses a high reluctance (magnetic flux resistance) relative to the soft iron material.

Summary of the present invention

The proposed invention is a new vibrator of variable reluctance type which is characterized in
10 that the signal flux is closed through the bobbin body and yoke as well as by two or more common air gaps where biasing flux and signal flux cooperates for generating the signal force. Both the bobbin body and yoke are made of material which leads magnetism very well, such as e.g., specially prepared soft iron material. The permanent magnets generating biasing flux can be placed in many different ways under the condition that the biasing flux in each
15 embodiment is led in such a way that it cooperates with the signal flux in the air gaps for generating the signal force in accordance with Equ. 1. Different from known technology the signal flux, in the proposed solution herein, is closed through the soft iron material and air gaps without passing the permanent magnet(s). One advantage using this solution is that the efficiency of the vibrator is improved as the permanent magnets, as mentioned above, in
20 general have bad dynamic (signal providing) properties compared with the soft iron material. Another advantage is that the static flux cooperates in the air gaps according to the principle of Abalanced armature@ so that the static forces eliminates each other. This means that the vibrator can be made smaller for a given resonance frequency as the returning spring (the spring element) can be softer as it need not counteract any static force in the neutral position
25 and the counter mass can thus be lighter, i.e., smaller to a corresponding degree.

Another advantage using the balanced armature is that even the quadratic distortion terms will be outbalanced. Most of all it is due for the second harmonic overtone which otherwise can be very dominating at low frequencies, which is particularly annoying at audiometry vibrators.
30

The return to neutral position is secured by one or more spring elements. The spring elements can e.g., consist of plate springs with or without dampening coating. Furthermore the air gap can be provided small elastic pillows to provide for a progressive resiliency which also provides a soft restriction (compression) of high sounds. The pillows in the air gap
5 counteracts the possibility to air gap collapse as well.

In the two embodiments of the invention described in detail below, the coil and the permanent magnet(s), as different from known technology, been split in a new way which has been made possible due to the balanced hanging. In one unit the generation of the magnetic signal (coil
10 and bobbin body) flux is carried out, and in the other unit the generation of the magnetic biasing flux (permanent magnet(s) and yoke) is carried out. The spring element connects the two units while observing, as described above, that it is formed two or more air gaps between the units where the static forces are outbalanced and where magnet bias and signal flux cooperate for generating the signal force. The advantage splitting the units in this way is that
15 vibrational stress on the thin connecting lines to the coil become minimal as the coil via the bobbin body is connected to the skull bone which has a very high mechanical impedance (Håkansson et al, The mechanical point impedance of the human head, with and without skin penetration, J. Acoust. Soc. Am., Vol. 80, No. 4, Oct. 1986). At resonance frequency the counteracting unit will swing with relatively large amplitudes while the coil moves relatively
20 little and transfers, mainly, forces only. High reliability when it comes to the durability of the lines of the coil will be of utmost importance when the vibrator is implanted.

The application of the invention is not restricted to bone transmitting hearing aids but can, with advantage, also be used as audio metry vibrator and other loudspeaker applications as
25 well as vibration provider.

Description of the figures

- Figure 1: Prior art - cross-section of a conventional variable reluctance vibrator
- Figure 2: Cross-section of a first embodiment of the invention
- 30 Figure 3: Details of the first embodiment
- Figure 4: A second and preferred embodiment of the invention
- Figure 5: A general embodiment showing different magnet positions

Figure 6: A general embodiment showing Aouter@ air gaps only.

Detailed description

A first embodying example according to the present invention is shown in Figure 2. The picture of the embodiment has a substantially circular symmetry. The vibrator consists of a generation unit 1 of signal flux and a biasing flux unit 2 which are elastically bound to each other by means of a plate spring element 3 and a guiding spring 4. The generation unit of signal flux 1 consists of a bobbin body 5, adapter yoke 6, and a coil 7, all been fixedly attached to each other. The fact that the upper arm of the bobbin body 5 is shortened for being adaptable to the adapter yoke 6 is only dependent upon the fact that it shall be simple to mount the circular yoke 9. From a magnetic point of view the bobbin body and the adapter yoke to be regarded as an integral unit. The biasing flux unit 2 consists of permanent magnet 8, yoke 9, bottom plate 10, pole 11, and counteracting mass 12, all fixedly connected to each other. Between the generation unit 1 of signal flux and the biasing flux unit 2 there are created circular radially extending axial air gaps 13a and 13b, through which the biasing flux Φ_0 and the signal flux Φ_1 are led in such a way that the axial forces in the air gaps, acting between the units, works in push-pull mode. The term axial direction means the direction which is parallel to the direction shown by the double directed arrows which show the direction of the signal force (F_{signal}) of Figures 1-6.

The effect of this solution is evident from Equ. 3-5 below:

$$F_1 \propto \frac{(\Phi_0 + \Phi_-)^2}{2} = \frac{\Phi_0^2}{4} + \Phi_- \cdot \Phi_0 + \Phi_-^2 \quad \text{Equ. 3}$$

$$5 \quad F_2 \propto \frac{(\Phi_0 - \Phi_-)^2}{2} = \frac{\Phi_0^2}{4} - \Phi_- \cdot \Phi_0 + \Phi_-^2 \quad \text{Equ. 4}$$

$$F_{\text{tot}} = F_1 - F_2 = F_{\text{signal}} \propto 2 \cdot \Phi_0 \cdot \Phi_- \quad \text{Equ. 5}$$

- 10 As evident the two static forces ($\Phi_0^2/4$) and the distortion term (Φ_-^2) will become outbalanced and the remainder is the axially directed signal force F_{signal} , se Equ 5. A very important advantage using this construction is that the signal flux is substantially closed through soft iron 5, 6, 9 without passing the permanent magnet 8. In this embodying example the signal flux way around the coil also shortest possible which is important to reduce the iron losses. Completely
15 independent of the signal flux circuit the permanent flux Φ_0 can be controlled by varying the thickness of the radial air gap 14.

The connecting lines of the coil is soldered to the circuit board 15. As the coil and coil lines are fixedly connected to the adapter yoke, which in turn is conected to the skull bone which has a
20 very high mechanical impedance, the mechanical stress on the coil lines will be minimized. That part of the vibrator which will show large vibration amplitudes is the rigid and vibrational insensitive counteracting unit.

It is important to note that the flux lines in the embodying example described herein are only
25 symbolically drawn and describe in which parts the main flux runs. In reality the fluxes are distributed across the cross-section surfaces and leakage outside the physical components exist. In this embodiment the leakage of signal flux which takes place through the permanent magnet to add to the generation of signal force when it passes the upper air gap 13a.

30 In figure 3 it i shown that the air gaps 13a and 13b can be provided with cushions of a suitable elastic materil 15, e.g., silicone rubber, which prevents collapse of the air gap. Further, there is shown that the air gaps can be formed by somewhat inclined surfaces in order to better distribute the magnetic fluxes in the air gaps and to prevent air gap collapse. Finally, in figure 3 it is shown that the coil 7 can be fixedly attached in a simple way to the yoke 9 in stead of to the bobbin body

5 using a suitable glue.

Connection to the load (e.g., a titanium fixture implanted into the temporal bone or the house
in an audiometry vibrator) can be made either via the signal flux unit 1 or the biasing flux
5 unit 2. In the embodiment disclosed here (figure 2) a connection to the signal flux unit is
shown only.

In the above description of the vibrator it is supposed to be completely circular symmetric but
it can likewise be rectangular symmetric. At rectangular symmetry the yoke 9 and the
10 permanent magnet 8 are divided into two parts. The one pair of the yoke and the permanent
magnet (now being rectangular as to their form) is fitted into the left opening of the bobbin
body and the other pair of yoke and permanent magnet is fitted into the right opening in the
same way as shown by the cross-section of figure 2.

15 By using, as in this first circular symmetric embodiment (figures 2 and 3) only one magnet a
construction is obtained which will obtain less possible geometric dimensions. The
construction has, however, turned out to be hard to produce, and it is hard to inspect and
control the radial air gap 14. Further it is requested a relatively stiff spring to secure that the
balanced air gaps are maintained as this middle point is unstable from a force point of view.

20

In figure 4 there is shown a second and preferred embodying example which completely or
partly solves the drawbacks of the first embodiment. The vibrator has hereby a rectangular
symmetry but can also be realized using circular symmetry. The now totally integral H-formed
bobbin body 20 is elastically hanged using two spring elements 21 to the biasing flux uunit
25 22. The biasing flux unit consists of two yokes 23, four magnets 24a, b, c, d, four biasing
yokes 28a, b, c, d, and a counter acting mass 25. Each magnet biases the neighbouring inner
air gap 26a, b, c, d, but the biasing flux runs through the outer air gaps 27a, b, c, d, and the
through the bias yokes 28a, b, c, d, as well. The spring element 21 can be made as plate
springs with or without dampening coating. One or more of the air gaps can also here be
30 provided with an elastic material e.g., silicone rubber to prevent air gaps collapse (not shown
in figure 4). The circuit board 29 for soldering the lines of the coil 7 to, is fixedly connected to
the bobbin body to avoid unnecessary vibrational stress on the connecting lines.

An substantial advantage using this embodiment compared to the one according to figure 2 is that the mounting becomes easier and that the trimming of suitable air gaps and bias flux to provide a stable and optimal signal force development is facilitated. The air gaps can be
5 inspected from the outside as well.

Another advantage using this construction where the bias flux runs through both the inner 26 and the outer 27 air gaps are, that the return to the middle point (the balanced position) becomes more easy as a reduced inner air gap (e.g., 26a) compensates by a simultaneously
10 increased outer air gap 27a. Finally, all leakage of signal flux through the permanent magnet via the outer air gaps is fully utilized at signal force generation.

If the vibrator shall be implanted it can be housed in a shell 30 of a tissue compatible material e.g., titanium. The housing consists, suitably, of two halves which are laser welded together
15 (not shown in figure 4). The shell has a protrusion 31 with e.g., threads 32 for connection to the load.

As previously mentioned the permanent magnets can, to produce a static flux, be placed in a number of different ways. For example the magnets, besides the positions 24a, b, c, d, also be
20 placed according to 40a, b, c, d or 41a, b, in figure 5 or according to 50a, b, c, d, of figure 6. The embodiments according to figures 5 and 6 can have rectangular or circular symmetry.

The embodiments of figures 2, 4 and 5 have a H-shaped bobbin body where the signal forces are developed mainly in air gaps which are formed between the yoke(s) and the inner sides
25 13a, b and 26a, b, c, d, of the arms of the H-shaped bobbin body - which are here called inner air gaps. In the embodiment of figure 6 the signal forces are developed in air gaps shaped on the outside 53a, b, c, d, of the arms of the H-shaped bobbin body 51 - which are called outer air gaps. A drawback of the embodiment of figure 6 may be that the magnetic signal flux way through the yoke 52 becomes longer than in the other embodiments and thereby the losses in
30 the iron material can be expected to be larger. Another drawback is the leakage of the signal flux through the magnets 50a, b, c, d may reduce the signal force generation.

It is evident from the embodiments of figure 2, 4, 5, 6 each individually or in combination that there are a number of different possibilities to realize/introduce biasing flux from the permanent magnets. The technical effect and the specific solution of the signal flux circuit including the air gaps and the interaction with biasing flux to generate the signal force is the
5 same in all embodiments.

In spite of the fact that all embodiments have been presented to describe the invention it is evident that the one skilled in the art may modify, add or reduce details without diverging from the scope and basics of the present invention as defined in the following claims.
10

CLAIMS

1. Device for generating or monitoring vibrations in accordance with the variable reluctance principle consisting of a coil (7) for generating/monitoring a magnetic signal flux, a bobbin
5 body of a magnetic conductive material (5, and 6; 20; 51), one or more yokes of magnetic conductive material (9; 23; 52), and one or more permanent magnets for generating a magnetic biasing flux, and one or more permanent magnets (8; 24a, b, c, d; 40a, b, c, d; 41a, b; 50a, b, c, d) for generating magnetic biasing flux,
characterized in
- 10 that the signal flux being generated/monitored by the coil is closed through the bobbin body and the yoke(s) as well as through two or more air gaps (13a, b, c, d; 26a, b, c, d; 53a, b, c, d) created between yoke and bobbin body, and wherein the permanent magnet(s) are arranged in such a way that its/their static flux coincides with and cooperates with the signal flux of the
15 air gaps so that the static forces between the yoke(s) and the bobbin body are outbalanced and so that axial signal forces are generated or axial movements are monitored, alternatively, between the yoke(s) and the bobbin body by voltage induced in the coil.
2. Device according to claim 1,
characterized in that the air gaps are axial.
- 20
3. Device according to claims 1-2,
characterized in that the axial air gaps are substantially radially extending.
4. Device according to claim 1,
25 **characterized** in that the coil can be fixed either to the bobbin body or the yoke(s).
5. Device according to claims 1-4,
characterized in that the bobbin body is H-shaped and that the air gaps are formed at the inside and/or at the outside of the arms and yoke(s) of the H-shaped bobbin body.

6. Device according to claims 1 and 5,

characterized in that the bobbin body, yoke(s) and magnet(s) are made according to circular or rectangular symmetry.

5

7. Device according to claim 6,

characterized in that the yoke(s) and bobbin body are resiliently connected to each other by means of one or more spring elements (3, 4; 21a, b) having suitable elastic properties to secure a stable air gap and to provide the desired resonance frequency.

10

8. Device according to claim 7,

characterized in that the spring elements are plate springs provided with dampening mass.

9. Device according to claim 8,

15 **characterized** in that elastic and dampening cushions (15) are provided in one or more of the common air gaps.

10. Device for generating or monitoring vibrations in accordance with the variable reluctance principle consisting of a first unit containing a soft iron material (9, 10, 11; 23a, b, 28a, b, c, d; 51; 20 52) and one or more permanent magnets (8; 24a,b,c,d; 40a,b,c,d; 41a,b; 50a,b,c,d) for generating magnetic biasing flux and a second unit containing soft iron material and a coil (7) for generating a magnetic signal flux according to claim 1,

characterized in

25 that the units are resiliently connected to each other by means of one or more spring elements (3, 4; 21a,b) having elastic properties to secure a stable air gap and to obtain a resonance frequency.

11. Device according to claim 10,

characterized in that the spring elements are plate springs provided with dampening mass.

12. Device according to claim 11,

characterized in that cushions having elastic and dampening properties are arranged in one or more of the common air gaps.

5

13. Device according to claim 10,

characterized in that the vibrator is enclosed in a shell (30) of tissue compatible material, such as titanium.

10 14. Device according to claim 13,

characterized in that the shell consists of two halves being laser welded together.

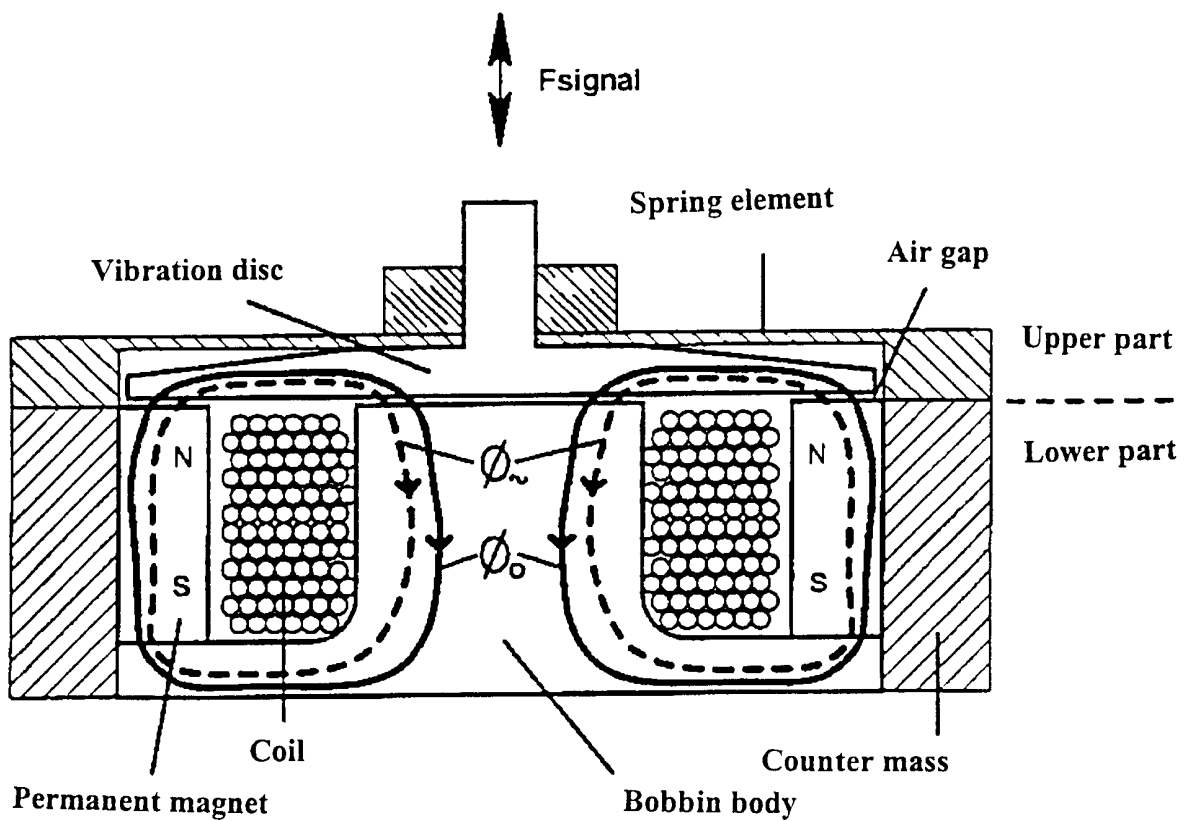

Fig.1

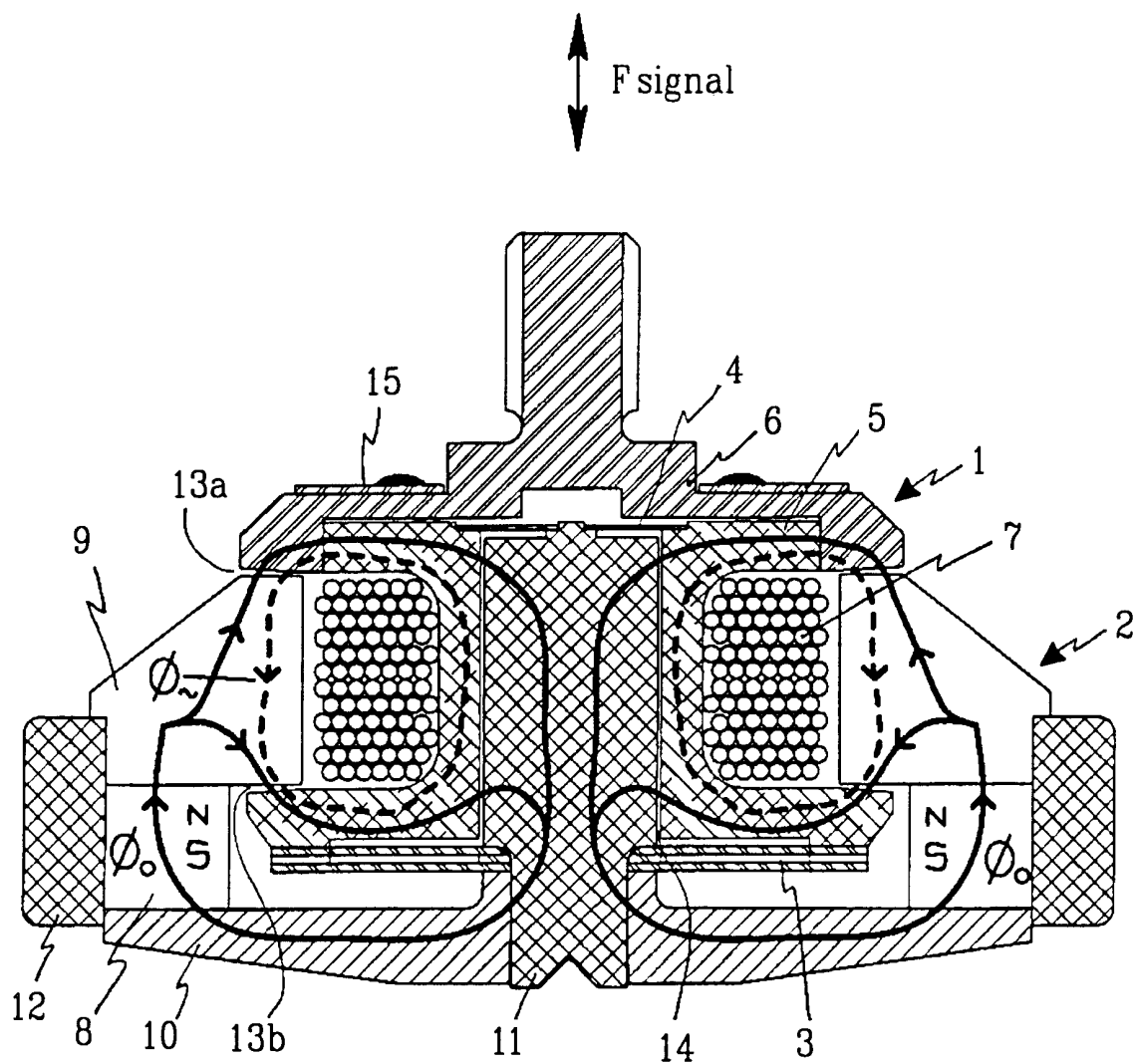

Fig.2

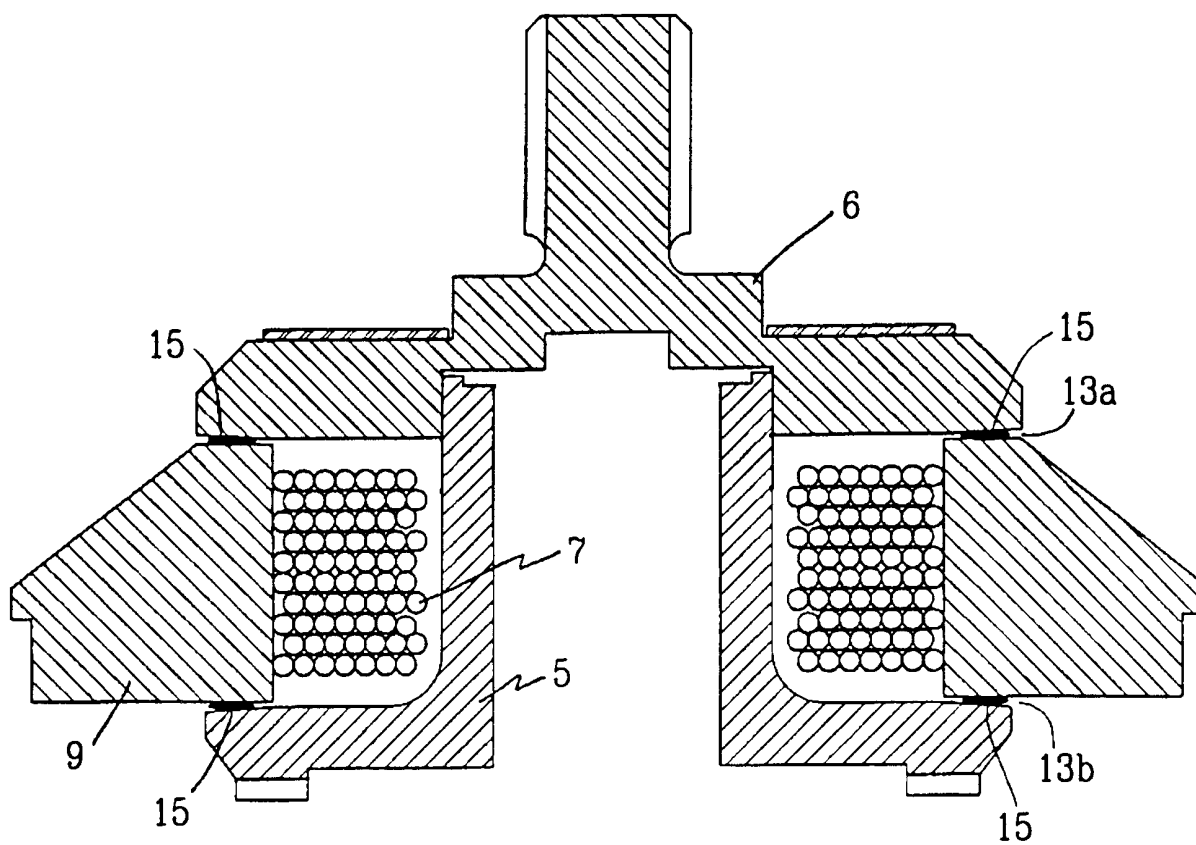

Fig.3

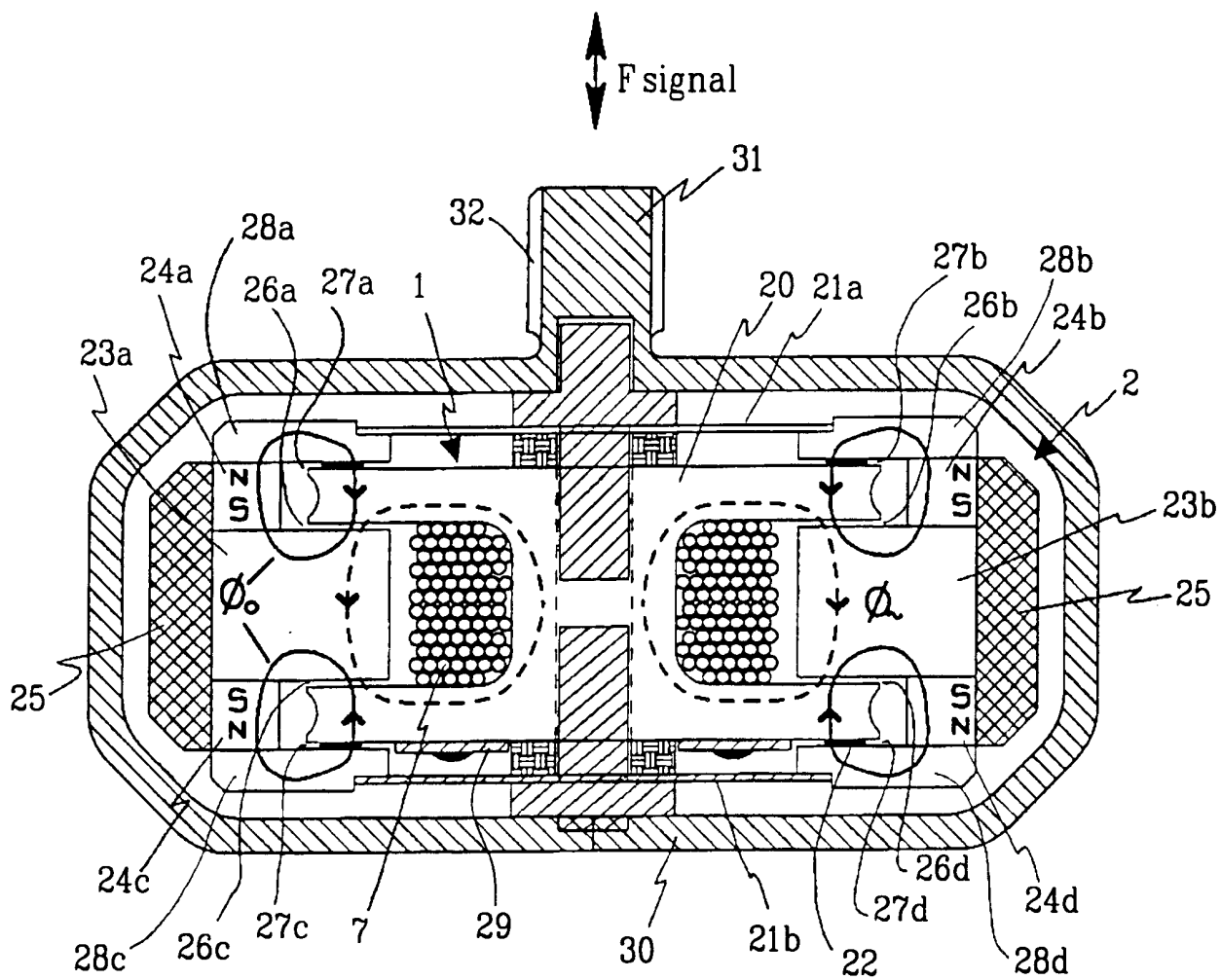

Fig.4

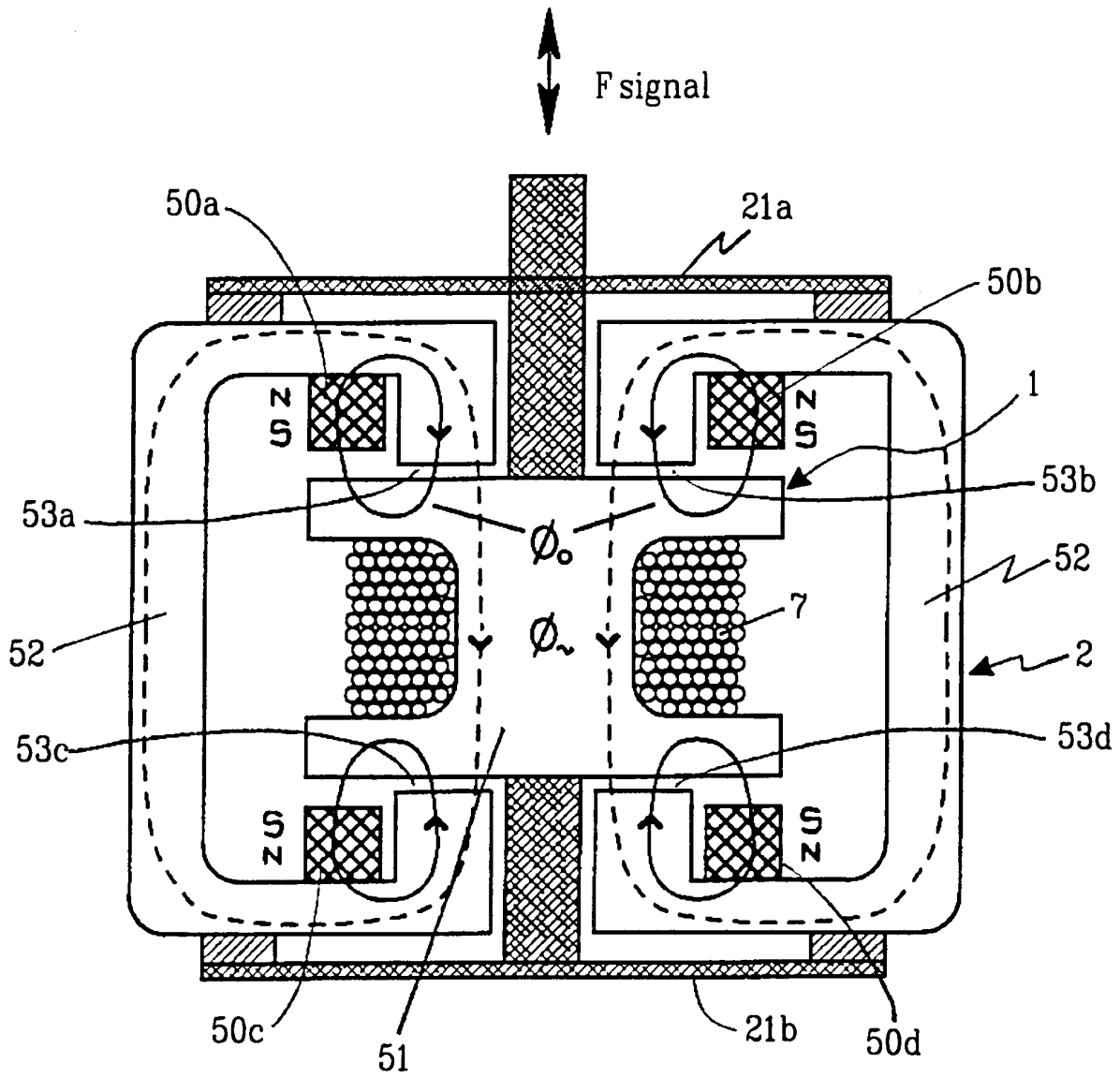

Fig.6

INTERNATIONAL SEARCH REPORT

International application No.

PCT/SE 01/00484

A. CLASSIFICATION OF SUBJECT MATTER		
IPC7: H04R 25/02, H04R 9/00, H04R 9/02 According to International Patent Classification (IPC) or to both national classification and IPC		
B. FIELDS SEARCHED		
Minimum documentation searched (classification system followed by classification symbols)		
IPC7: H04R		
Documentation searched other than minimum documentation to the extent that such documents are included in the fields searched		
SE,DK,FI,NO classes as above		
Electronic data base consulted during the international search (name of data base and, where practicable, search terms used)		
C. DOCUMENTS CONSIDERED TO BE RELEVANT		
Category*	Citation of document, with indication, where appropriate, of the relevant passages	Relevant to claim No.
E,X	SE 514929 C2 (ENTIFIC MEDICAL SYSTEMS AB), 21 May 2001 (21.05.01) --	1-14
E,X	SE 514930 C2 (ENTIFIC MEDICAL SYSTEMS AB), 21 May 2001 (21.05.01) --	1-14
A	US 5528697 A (SAITO), 18 June 1996 (18.06.96) --	1-14
A	WO 9709858 A1 (VERITY GROUP PLC), 13 March 1997 (13.03.97) -- -----	1-14
<input type="checkbox"/> Further documents are listed in the continuation of Box C. <input checked="" type="checkbox"/> See patent family annex.		
* Special categories of cited documents: "A" document defining the general state of the art which is not considered to be of particular relevance "E" earlier application or patent but published on or after the international filing date "L" document which may throw doubts on priority claim(s) or which is cited to establish the publication date of another citation or other special reason (as specified) "O" document referring to an oral disclosure, use, exhibition or other means "P" document published prior to the international filing date but later than the priority date claimed "I" later document published after the international filing date or priority date and not in conflict with the application but cited to understand the principle or theory underlying the invention "X" document of particular relevance: the claimed invention cannot be considered novel or cannot be considered to involve an inventive step when the document is taken alone "Y" document of particular relevance: the claimed invention cannot be considered to involve an inventive step when the document is combined with one or more other such documents, such combination being obvious to a person skilled in the art "&" document member of the same patent family		
Date of the actual completion of the international search		Date of mailing of the international search report
30 May 2001		08-06-2001
Name and mailing address of the ISA / Swedish Patent Office Box 5055, S-102 42 STOCKHOLM Facsimile No. +46 8 666 02 86		Authorized officer Henrik Andersson /OGU Telephone No. +46 8 782 25 00

INTERNATIONAL SEARCH REPORT

Information on patent family members

30/04/01

International application No.

PCT/SE 01/00484

Patent document cited in search report			Publication date	Patent family member(s)			Publication date
SE	514929	C2	21/05/01	NONE			

SE	514930	C2	21/05/01	NONE			

US	5528697	A	18/06/96	JP	4281657	A	07/10/92
				JP	2929745	B	03/08/99
				JP	4281240	A	06/10/92

INTERNATIONAL SEARCH REPORT
Information on patent family members

30/04/01

International application No.
PCT/SE 01/00484

Patent document cited in search report	Publication date	Patent family member(s)	Publication date
WO 9709858 A1	13/03/97	AT 176826 T	15/03/99
		AT 177281 T	15/03/99
		AT 177282 T	15/03/99
		AT 177574 T	15/03/99
		AT 177575 T	15/03/99
		AT 177576 T	15/03/99
		AT 177577 T	15/03/99
		AT 177578 T	15/03/99
		AT 177579 T	15/03/99
		AT 177580 T	15/03/99
		AT 177581 T	15/03/99
		AT 177582 T	15/03/99
		AT 177583 T	15/03/99
		AT 179043 T	15/04/99
		AT 179044 T	15/04/99
		AT 179045 T	15/04/99
		AT 179296 T	15/05/99
		AT 179297 T	15/05/99
		AT 179563 T	15/05/99
		AT 179564 T	15/05/99
		AT 186617 T	15/11/99
		AU 699890 B	17/12/98
		AU 702863 B	11/03/99
		AU 702865 B	11/03/99
		AU 702867 B	11/03/99
		AU 702873 B	11/03/99
		AU 702920 B	11/03/99
		AU 702999 B	11/03/99
		AU 703000 B	11/03/99
		AU 703004 B	11/03/99
		AU 703015 B	11/03/99
		AU 703020 B	11/03/99
		AU 703058 B	11/03/99
		AU 703061 B	11/03/99
		AU 703065 B	11/03/99
		AU 703071 B	11/03/99
		AU 703122 B	18/03/99
		AU 703198 B	18/03/99
		AU 703296 B	25/03/99
		AU 704227 B	15/04/99
		AU 704299 B	22/04/99
		AU 705592 B	27/05/99
		AU 6880196 A	27/03/97
		AU 6880296 A	27/03/97
		AU 6880396 A	27/03/97
		AU 6880496 A	27/03/97
		AU 6880596 A	27/03/97
		AU 6880696 A	27/03/97
		AU 6880796 A	27/03/97
		AU 6880896 A	27/03/97
		AU 6880996 A	27/03/97
		AU 6881096 A	27/03/97
		AU 6881296 A	27/03/97
		AU 6881396 A	27/03/97
		AU 6881496 A	27/03/97

INTERNATIONAL SEARCH REPORT
Information on patent family members

30/04/01

International application No.

PCT/SE 01/00484

Patent document cited in search report	Publication date	Patent family member(s)	Publication date
WO 9709858 A1	13/03/97	AU 6881596 A	27/03/97
		AU 6881696 A	27/03/97
		AU 6881896 A	27/03/97
		AU 6881996 A	27/03/97
		AU 6882096 A	27/03/97
		AU 6882196 A	27/03/97
		AU 6882296 A	27/03/97
		AU 6882396 A	27/03/97
		BR 9610355 A	21/12/99
		BR 9610374 A	21/12/99
		BR 9610426 A	21/12/99
		BR 9610427 A	29/06/99
		BR 9610428 A	21/12/99
		BR 9610436 A	17/02/99
		BR 9610437 A	17/02/99
		BR 9610440 A	17/02/99
		BR 9610450 A	15/06/99
		BR 9610466 A	02/03/99
		BR 9610502 A	21/12/99
		BR 9610545 A	21/12/99
		BR 9610553 A	21/12/99
		CA 2229857 A	13/03/97
		CA 2229858 A	13/03/97
		CA 2229998 A	13/03/97
		CA 2230053 A	13/03/97
		CA 2230064 A	13/03/97
		CA 2230075 A	13/03/97
		CA 2230104 A	13/03/97
		CA 2230154 A	13/03/97
		CA 2230155 A	13/03/97
		CA 2230161 A	13/03/97
		CA 2230234 A	13/03/97
		CA 2230438 A	13/03/97
		CA 2230444 A	13/03/97
		CA 2230449 A	13/03/97
		CA 2230459 A	13/03/97
		CA 2230461 A	13/03/97
		CA 2230701 A	13/03/97
		CA 2230702 A	13/03/97
		CA 2230704 A	13/03/97
		CA 2234944 A	13/03/97
		CN 1194085 A	23/09/98
		CN 1194086 A	23/09/98
		CN 1195454 A	07/10/98
		CN 1195455 A	07/10/98
		CN 1195456 A	07/10/98
		CN 1195457 A	07/10/98
		CN 1195458 A	07/10/98
		CN 1195459 A	07/10/98
		CN 1195460 A	07/10/98
		CN 1195461 A	07/10/98
		CN 1195462 A	07/10/98
		CN 1195463 A	07/10/98
		CZ 9800572 A	15/07/98
		CZ 9800573 A	15/07/98

INTERNATIONAL SEARCH REPORT
Information on patent family members

30/04/01

International application No.
PCT/SE 01/00484

Patent document cited in search report	Publication date	Patent family member(s)	Publication date
WO 9709858 A1	13/03/97	CZ 9800574 A	15/07/98
		CZ 9800575 A	15/07/98
		CZ 9800576 A	11/11/98
		CZ 9800577 A	15/07/98
		CZ 9800578 A	15/07/98
		CZ 9800579 A	15/07/98
		CZ 9800580 A	15/07/98
		CZ 9800581 A	15/07/98
		CZ 9800582 A	15/07/98
		CZ 9800583 A	15/07/98
		CZ 9800584 A	12/08/98
		CZ 9800585 A	12/08/98
		DE 69601554 D,T	16/09/99
		DE 69601647 D,T	16/09/99
		DE 69601648 D,T	16/09/99
		DE 69601723 D,T	16/09/99
		DE 69601724 D,T	16/09/99
		DE 69601725 D,T	16/09/99
		DE 69601726 D,T	16/09/99
		DE 69601728 D,T	16/09/99
		DE 69601729 D,T	16/09/99
		DE 69601731 D,T	16/09/99
		DE 69601732 D,T	16/09/99
		DE 69601733 D,T	16/09/99
		DE 69601734 D,T	16/09/99
		DE 69602100 D,T	16/09/99
		DE 69602101 D,T	16/09/99
		DE 69602102 D,T	16/09/99
		DE 69602203 D,T	16/09/99
		DE 69602204 D,T	16/09/99
		DE 69602279 D,T	16/09/99
		DE 69602281 D,T	16/09/99
		DE 69605123 D,T	06/04/00
		DK 847567 T	20/09/99
		DK 847659 T	27/09/99
		DK 847660 T	27/09/99
		DK 847661 T	27/03/00
		DK 847662 T	27/09/99
		DK 847663 T	27/09/99
		DK 847664 T	08/11/99
		DK 847665 T	25/10/99
		DK 847666 T	04/10/99
		DK 847667 T	04/10/99
		DK 847668 T	25/10/99
		DK 847669 T	27/09/99
		DK 847670 T	27/09/99
		DK 847671 T	27/09/99
		DK 847672 T	27/09/99
		DK 847673 T	27/09/99
		DK 847674 T	25/10/99
		DK 847675 T	27/09/99
		DK 847676 T	25/10/99
		DK 847677 T	25/10/99
		DK 847678 T	25/10/99
		EA 980172 A	29/10/98

INTERNATIONAL SEARCH REPORT
Information on patent family members

30/04/01

International application No.
PCT/SE 01/00484

Patent document cited in search report	Publication date	Patent family member(s)	Publication date
WO 9709858 A1	13/03/97	EP 0847567 A,B	17/06/98
		EP 0847659 A,B	17/06/98
		EP 0847660 A,B	17/06/98
		EP 0847661 A,B	17/06/98
		SE 0847661 T3	
		EP 0847662 A,B	17/06/98
		EP 0847663 A,B	17/06/98
		EP 0847664 A,B	17/06/98
		EP 0847665 A,B	17/06/98
		EP 0847666 A,B	17/06/98
		EP 0847667 A,B	17/06/98
		EP 0847668 A,B	17/06/98
		EP 0847669 A,B	17/06/98
		EP 0847670 A,B	17/06/98
		EP 0847671 A,B	17/06/98
		EP 0847672 A,B	17/06/98
		EP 0847673 A,B	17/06/98
		EP 0847674 A,B	17/06/98
		EP 0847675 A,B	17/06/98
		EP 0847676 A,B	17/06/98
		EP 0847677 A,B	17/06/98
		EP 0847678 A,B	17/06/98
		ES 2130845 T	01/07/99
		ES 2130846 T	01/07/99
		ES 2130847 T	01/07/99
		ES 2130848 T	01/07/99
		ES 2130849 T	01/07/99
		ES 2131407 T	16/07/99
		ES 2131408 T	16/07/99
		ES 2131409 T	16/07/99
		ES 2131410 T	16/07/99
		ES 2131953 T	01/08/99
		ES 2131954 T	01/08/99
		ES 2131955 T	01/08/99
		ES 2131956 T	01/08/99
		ES 2131957 T	01/08/99
		ES 2131958 T	01/08/99
		ES 2132952 T	16/08/99
		ES 2132953 T	16/08/99
		ES 2132954 T	16/08/99
		ES 2132955 T	16/08/99
		ES 2133996 T	16/09/99
		ES 2140127 T	16/02/00
		GB 9517918 D	00/00/00
		HK 1008591 A	00/00/00
		HK 1008593 A	00/00/00
		HK 1008596 A	00/00/00
		HK 1008626 A	00/00/00
		HK 1008636 A	00/00/00
		HK 1008637 A	00/00/00
		HK 1008638 A	00/00/00
		HK 1008639 A	00/00/00
		HK 1008640 A	00/00/00
		HK 1008641 A	00/00/00
		HK 1008642 A	00/00/00

INTERNATIONAL SEARCH REPORT
Information on patent family members

30/04/01

International application No.
PCT/SE 01/00484

Patent document cited in search report	Publication date	Patent family member(s)	Publication date
WO 9709858 A1	13/03/97	HK 1008643 A	00/00/00
		HK 1008644 A	00/00/00
		HK 1008645 A	00/00/00
		HK 1008646 A	00/00/00
		HK 1008647 A	00/00/00
		HK 1008648 A	00/00/00
		HK 1008649 A	00/00/00
		HK 1008650 A	00/00/00
		HK 1008651 A	00/00/00
		HK 1008652 A	00/00/00
		HU 9802067 A	28/12/98
		HU 9802389 A	01/02/99
		HU 9900168 A	28/04/99
		HU 9900177 A	28/04/99
		HU 9900179 A	28/04/99
		HU 9900181 A	28/05/99
		HU 9901393 A	30/08/99
		HU 9901396 A	30/08/99
		HU 9903872 A	28/03/00
		HU 9903873 A	28/03/00
		HU 9903875 A	28/03/00
		HU 9903877 A	28/03/00
		HU 9903879 A	28/03/00
		IL 123371 D	00/00/00
		IL 123374 D	00/00/00
		IL 123375 D	00/00/00
		IL 123438 D	00/00/00
		IL 123480 D	00/00/00
		IL 123481 D	00/00/00
		IL 123482 D	00/00/00
		IL 123483 D	00/00/00
		IL 123484 D	00/00/00
		IL 123485 D	00/00/00
		IL 123486 D	00/00/00
		IL 123487 D	00/00/00
		IL 123488 D	00/00/00
		IL 123489 D	00/00/00
		JP 11512245 T	19/10/99
		JP 11512246 T	19/10/99
		JP 11512247 T	19/10/99
		JP 11512248 T	19/10/99
		JP 11512249 T	19/10/99
		JP 11512250 T	19/10/99
		JP 11512251 T	19/10/99
		JP 11512252 T	19/10/99
		JP 11512253 T	19/10/99
		JP 11512254 T	19/10/99
		JP 11512255 T	19/10/99
		JP 11512256 T	19/10/99
		JP 11512257 T	19/10/99
		JP 11512258 T	19/10/99
		JP 11512259 T	19/10/99
		JP 11512260 T	19/10/99
		JP 11512261 T	19/10/99
		JP 11512262 T	19/10/99

INTERNATIONAL SEARCH REPORT

Information on patent family members

30/04/01

International application No.

PCT/SE 01/00484

Patent document cited in search report	Publication date	Patent family member(s)	Publication date
WO 9709858 A1	13/03/97	JP 11513210 T	09/11/99
		JP 11514509 T	07/12/99
		JP 11515122 T	21/12/99
		NZ 316543 A	28/10/98
		NZ 316545 A	27/05/98
		NZ 316546 A	27/05/98
		NZ 316547 A	28/10/99
		NZ 316549 A	27/05/98
		NZ 316550 A	28/10/98
		NZ 316551 A	27/05/98
		NZ 316552 A	27/05/98
		NZ 316555 A	27/05/98
		NZ 316556 A	27/05/98
		NZ 316558 A	28/10/98
		NZ 316562 A	27/05/98
		NZ 316563 A	27/05/98
		NZ 316565 A	25/11/98
		PL 325211 A	06/07/98
		PL 325235 A	06/07/98
		PL 325236 A	06/07/98
		PL 325237 A	06/07/98
		PL 325239 A	06/07/98
		PL 325244 A	06/07/98
		PL 325245 A	06/07/98
		PL 325246 A	06/07/98
		PL 325248 A	06/07/98
		PL 325272 A	20/07/98
		PL 325273 A	20/07/98
		PL 325274 A	20/07/98
		PL 325284 A	20/07/98
		PL 325285 A	20/07/98
		SI 847661 T	00/00/00
		SK 25398 A	09/09/98
		SK 25498 A	07/10/98
		SK 25598 A	07/10/98
		SK 25698 A	09/09/98
		SK 25798 A	09/09/98
		SK 25898 A	09/09/98
		SK 25998 A	09/09/98
		SK 26098 A	09/09/98
		SK 26198 A	09/09/98
		SK 26298 A	09/09/98
		SK 26398 A	09/09/98
		SK 26498 A	09/09/98
		SK 26598 A	09/09/98
		SK 26698 A	09/09/98
		TR 9800357 T	00/00/00
		TR 9800358 T	00/00/00
		TR 9800359 T	00/00/00
		TR 9800360 T	00/00/00
		TR 9800361 T	00/00/00
		TR 9800362 T	00/00/00
		TR 9800364 T	00/00/00
		TR 9800365 T	00/00/00
		TR 9800366 T	00/00/00

INTERNATIONAL SEARCH REPORT

Information on patent family members

30/04/01

International application No.

PCT/SE 01/00484

Patent document cited in search report	Publication date	Patent family member(s)	Publication date
WO 9709858 A1	13/03/97	TR 9800367 T	00/00/00
		TR 9800368 T	00/00/00
		TR 9800369 T	00/00/00
		TR 9800370 T	00/00/00
		TR 9800372 T	00/00/00
		US 6003766 A	21/12/99
		US 6151402 A	21/11/00
		US 6181799 B	30/01/01
		US 6188775 B	13/02/01
		US 6192136 B	20/02/01
		US 6198831 B	06/03/01
		US 6201878 B	13/03/01
		US 6215881 B	10/04/01
		WO 9709698 A	13/03/97
		WO 9709840 A	13/03/97
		WO 9709841 A	13/03/97
		WO 9709842 A	13/03/97
		WO 9709843 A	13/03/97
		WO 9709844 A	13/03/97
		WO 9709845 A	13/03/97
		WO 9709846 A	13/03/97
		WO 9709847 A	13/03/97
		WO 9709848 A	13/03/97
		WO 9709849 A	13/03/97
		WO 9709852 A	13/03/97
		WO 9709853 A	13/03/97
		WO 9709854 A	13/03/97
		WO 9709855 A	13/03/97
		WO 9709856 A	13/03/97
		WO 9709857 A	13/03/97
		WO 9709859 A	13/03/97
		WO 9709861 A	13/03/97
		WO 9709862 A	13/03/97
		GB 9522281 D	00/00/00
		GB 9606836 D	00/00/00
		HU 9904010 A	28/04/00
