



INTERNATIONAL APPLICATION PUBLISHED UNDER THE PATENT COOPERATION TREATY (PCT)

<p>(51) International Patent Classification ⁶ : A61B 17/11</p>	<p>A2</p>	<p>(11) International Publication Number: WO 97/12555 (43) International Publication Date: 10 April 1997 (10.04.97)</p>
<p>(21) International Application Number: PCT/US96/15926 (22) International Filing Date: 3 October 1996 (03.10.96) (30) Priority Data: 538,575 3 October 1995 (03.10.95) US 705,190 29 August 1996 (29.08.96) US (71) Applicant: CEDARS-SINAI MEDICAL CENTER [US/US]; 8700 Beverly Boulevard, Los Angeles, CA 90048 (US). (72) Inventors: POPOV, Alexander, 8342 West Fourth Street, Los Angeles, CA 90048 (US). BARATH, Peter, 344 South 7th Street, Hinsdale, IL 60521 (US). (74) Agent: POPLAWSKI, Edward, G.; Pretty, Schroeder & Poplawski, Suite 2000, 444 South Flower Street, Los Angeles, CA 90071 (US).</p>		<p>(81) Designated States: AL, AM, AT, AU, AZ, BA, BB, BG, BR, BY, CA, CH, CN, CU, CZ, DE, DK, EE, ES, FI, GB, GE, HU, IL, IS, JP, KE, KG, KP, KR, KZ, LC, LK, LR, LS, LT, LU, LV, MD, MG, MK, MN, MW, MX, NO, NZ, PL, PT, RO, RU, SD, SE, SG, SI, SK, TJ, TM, TR, TT, UA, UG, UZ, VN, ARIPO patent (KE, LS, MW, SD, SZ, UG), Eurasian patent (AM, AZ, BY, KG, KZ, MD, RU, TJ, TM), European patent (AT, BE, CH, DE, DK, ES, FI, FR, GB, GR, IE, IT, LU, MC, NL, PT, SE), OAPI patent (BF, BJ, CF, CG, CI, CM, GA, GN, ML, MR, NE, SN, TD, TG).</p> <p>Published <i>Without international search report and to be republished upon receipt of that report.</i></p>
<p>(54) Title: DEVICES FOR PERFORMING VASCULAR ANASTOMOSES</p>		
<p>(57) Abstract</p> <p>A method and devices are provided for performing end-to-side anastomoses between the severed end of a first hollow organ and the side-wall of a second hollow organ utilizing transluminal approach with endoscopic assistance, wherein the first and second hollow organs can be secured utilizing a biocompatible glue, clips or by suturing. In an alternative embodiment, the method utilizes a modified cutter catheter which is introduced into the first hollow organ in combination with a receiver catheter which is introduced into the second hollow organ. The distal end of the receiver catheter includes a receiver cavity and a selectively activatable magnetic material. The magnetic material is selected so that it will interact with a magnetically susceptible material disposed in the distal end of the modified cutter catheter when the modified cutter catheter is disposed in proximity to the proposed site for anastomosis whereby the severed end of the first hollow organ is matingly engaged with the side-wall of the second hollow organ. Thereafter, the severed end of the first hollow organ can be attached in sealing engagement with the side-wall utilizing clips, a biocompatible glue, or other suitable methods. The cutter is then activated to remove a portion of the side-wall of the second hollow organ, thereby creating an opening within the region of securement and establishing the anastomosis. These methods and devices find particular utility in coronary bypass surgery, including, in particular, where the first hollow organ is the left internal mammary artery (LIMA) and the second hollow organ is the left anterior descending coronary artery (LAD).</p>		

FOR THE PURPOSES OF INFORMATION ONLY

Codes used to identify States party to the PCT on the front pages of pamphlets publishing international applications under the PCT.

AM	Armenia	GB	United Kingdom	MW	Malawi
AT	Austria	GE	Georgia	MX	Mexico
AU	Australia	GN	Guinea	NE	Niger
BB	Barbados	GR	Greece	NL	Netherlands
BE	Belgium	HU	Hungary	NO	Norway
BF	Burkina Faso	IE	Ireland	NZ	New Zealand
BG	Bulgaria	IT	Italy	PL	Poland
BJ	Benin	JP	Japan	PT	Portugal
BR	Brazil	KE	Kenya	RO	Romania
BY	Belarus	KG	Kyrgystan	RU	Russian Federation
CA	Canada	KP	Democratic People's Republic of Korea	SD	Sudan
CF	Central African Republic	KR	Republic of Korea	SE	Sweden
CG	Congo	KZ	Kazakhstan	SG	Singapore
CH	Switzerland	LI	Liechtenstein	SI	Slovenia
CI	Côte d'Ivoire	LK	Sri Lanka	SK	Slovakia
CM	Cameroon	LR	Liberia	SN	Senegal
CN	China	LT	Lithuania	SZ	Swaziland
CS	Czechoslovakia	LU	Luxembourg	TD	Chad
CZ	Czech Republic	LV	Latvia	TG	Togo
DE	Germany	MC	Monaco	TJ	Tajikistan
DK	Denmark	MD	Republic of Moldova	TT	Trinidad and Tobago
EE	Estonia	MG	Madagascar	UA	Ukraine
ES	Spain	ML	Mali	UG	Uganda
FI	Finland	MN	Mongolia	US	United States of America
FR	France	MN	Mongolia	UZ	Uzbekistan
GA	Gabon	MR	Mauritania	VN	Viet Nam

DEVICES FOR PERFORMING VASCULAR ANASTOMOSES**BACKGROUND OF THE INVENTION**

This invention relates generally to the field of surgery and, more particularly, to a method and devices for performing anastomoses. More specifically, the present invention relates to a method and devices for performing end-to-side vascular anastomoses utilizing transluminal approach with endoscopic assistance, including, performing end-to-side anastomoses between intact thoracic or abdominal arteries and diseased coronary arteries.

Anastomosis is the union or joinder of one hollow or tubular organ to another so that the interior of the organs communicate with one another. There are generally two types of anastomosis: end-to-end and end-to-side. In an end-to-end anastomosis, the severed end of a first hollow organ is coupled, usually by suturing or stapling, to the severed end of a second hollow organ. In an end-to-side anastomosis, however, the severed end of a first hollow organ is connected around an opening cut into the side of a second hollow organ.

Typically, anastomoses are performed between airways, blood vessels, bowels, and urogenital lumens. The procedure for connecting blood vessels is referred to as vascular anastomosis. One of the best known surgical procedures utilizing vascular anastomoses is the coronary bypass. In the context of coronary artery disease, the flow of oxygenated blood to the myocardium of the heart is inhibited by a stenosis or obstruction in the coronary artery. This flow can be improved by providing a coronary artery bypass graft ("CABG") between the aorta and a point in the coronary artery distal to stenosis. Typically, a section of vein from the leg is removed and attached at

one end to the aorta and at the other end to the coronary artery utilizing end-to-side anastomoses. Such grafts are known as saphenous vein grafts. Alternatively, synthetic grafts can be utilized to effect the bypass.

5 While the typical coronary bypass procedure favorably affects the incidence and severity of angina in patients with coronary artery disease, a variety of risks are associated with such procedures. Among them are mortality, myocardial infarction, postoperative bleeding,
10 cerebrovascular accident, arrhythmias, wound or other infection, aortic dissection and limb ischemia. Furthermore, the vein grafts deteriorate over time, thereby resulting in the recurrence of angina, myocardial infarction and death. In addition, the costs of such
15 procedures are relatively high and the patient recovery relatively long.

 In an attempt to overcome such problems, a number of alternative approaches have been developed. For example,
20 artery to artery bypass procedures have been utilized in which an arterial source of oxygenated blood--such as the left internal mammary artery ("LIMA") or right internal mammary artery ("RIMA")-- is severed and anastomosed to
25 the obstructed coronary artery distally to the stenosis or occlusion. More recently, other arteries have been used in such procedures, including the inferior epigastric arteries and gastroepiploic arteries. In general, artery to artery bypass procedures have demonstrated a better
30 patency rate as compared with autologous vein or synthetic grafts.

 While vascular anastomoses can be effective, and sometimes life-saving procedures, traditionally available

techniques have been associated with a number of complications. For example, conventional techniques for performing vascular anastomoses generally require an extensive incision in the patient's body. Such operations
5 are traumatic to the patient, involve a lengthy recovery, and a relatively high risk of infection or other complications.

In the context of coronary bypass surgery, for example, the bypass graft or artery-to-artery procedure is
10 traditionally performed using an open chest procedure. In particular, each procedure involves the necessity of a formal 20 to 25 cm incision in the chest of the patient, severing the sternum and cutting and peeling back various layers of tissue in order to give access to the heart and
15 arterial sources. As a result, these operations typically require large numbers of sutures or staples to close the incision and 5 to 10 wire hooks to keep the severed sternum together. Furthermore, such procedures leave an unattractive scar and are painful to the patient. Most
20 patients are out of work for a long period after such an operation and have restricted movement for several weeks. Such surgery often carries additional complications such as instability of the sternum, post-operative bleeding and mediastinal infection. Cutting through layers of the
25 patients tissue may also severely traumatize the tissue and upset the patients emotional equilibrium. Above all, open procedures are associated with long recuperation times.

Due to the risks attendant to such procedures, there
30 has been a need to develop procedures which minimize invasion of the patient's body tissue and resulting trauma. In this regard, limited open chest techniques have been developed in which the coronary bypass is

carried out using an abdominal (subxyphoid) approach or, alternatively, a "Chamberlain" incision (an approximately 8 cm incision at the sternocostal junction), thereby lessening the operating area and the associated complication rate. While the risks attendant to such procedures are generally lower than their open chest counterparts, there is still a need for a minimally invasive surgical technique. Nevertheless, each of these techniques is thoracotomic, requiring an incision to be made in the chest wall through which conventional surgical instruments are introduced to perform conventional coronary bypass surgery.

In order to reduce the risk of patient mortality, infection, and other complications associated with surgical techniques, it is advantageous and desirable to utilize endoscopic and thoracoscopic surgical techniques. Such procedures usually involve the use of surgical trocars which are used to puncture the abdomen or chest, thereby facilitating access to a body cavity through the cannula and a relatively small opening in the patient's body. Typically, such trocars have a diameter of about 3 mm to 15 mm. Surgical instruments and other devices such as fiber optic cameras can be inserted into the body cavity through the cannula. Advantageously, the use of trocars minimizes the trauma associated with many surgical procedures.

When traditional vascular anastomoses are performed, it is desirable to effect a suitable leak-proof connection between organs. Typically, such connections are established using suturing techniques. It is significant to note, however, that suturing of vascular structures is a tedious and time consuming process. Furthermore, these

suturing techniques are not readily adapted for to
endoscopic techniques where the surgeon's freedom of
access and movement are more limited. Thus, there is a
need for an alternative to these suturing techniques that
5 would expedite the procedure, and a further need for an
alternative that can be readily adapted for endoscopic
use.

Various stapling techniques are known for providing
anastomotic connections between organs, such as in
10 intestinal and colorectal anastomoses. Due to the size of
these devices, however, they are not easily adapted for
use with vascular organs or endoscopic techniques.
Furthermore, such techniques typically require penetration
of the organ wall. Thus, due to the increased likelihood
15 of clotting associated with penetration of the interior of
the vascular wall, these techniques have not found ready
application to the vascular system.

Recently, a surgical procedure and surgical clip have
been developed which are intended to facilitate the
20 anastomoses of vascular structures. In this technique,
the vascular tissues are approximated, partially everted,
and then clipped by applying the arms of the surgical clip
over the everted tissue and securing the clip so as to
hold the tissue together without penetrating the interior
25 wall of the vessel. Nevertheless, in order to properly
utilize these clips, the tissues should be everted. It
would be desirable if such clipping devices could be
adapted for endoscopic use. Further, it would be
desirable to eliminate the need for everting the tissue
30 prior to application of the clips in order to facilitate
endoscopic assisted anastomoses.

It should, therefore, be appreciated that there is a definite need for a method and devices for performing vascular anastomoses which minimize the risk of infection, trauma, and other complications associated with conventional surgery, and, in particular, a need for a device which can be utilized in conjunction with an endoscopic technique for vascular anastomoses. It will also be appreciated that there exists a need for methods and devices for performing vascular anastomoses utilizing endoscopic assistance in which the first hollow organ can be easily aligned and secured to the second hollow organ.

SUMMARY OF THE INVENTION

The present invention, which addresses these needs, resides in a method and devices for performing vascular anastomoses in a manner that tends to minimize the risk of infection, trauma, and other complications associated with conventional surgery. In this regard, the present invention combines transluminal and endoscopic techniques.

In the preferred embodiment, the present invention relates to a nonthoracotomic, minimally invasive method and devices for establishing end-to-side anastomoses between the severed end of a first hollow organ and the side wall of a second hollow organ utilizing transluminal approach with endoscopic assistance. A catheter having a selectively operable cutter adapted to remove a portion of the sidewall of the second hollow organ, is introduced into the first hollow organ until the distal end of the catheter is substantial adjacent to the severed end of the first hollow organ. The severed end is then positioned in

proximity to the proposed site for anastomosis of the side-wall of the second hollow organ. The severed end of the first hollow organ is secured in sealing engagement with the side-wall of the second hollow organ, thereby
5 defining a zone of securement. The cutter is activated to remove a portion of the side-wall of the second hollow organ within the zone of securement, thereby establishing the anastomosis.

In more detailed aspects of the invention, the distal
10 end of the catheter is sized and shaped to provide support to the severed end of the first hollow organ so that a plurality of clips may be applied to the seam between the severed end of the first hollow organ and the side-wall of the second hollow organ without the necessity of everting
15 the edges. Similarly, the catheter may be adapted to provide support to the severed end of the first hollow organ so that a biocompatible glue may be applied to the seam. Alternatively, the severed end of the first hollow organ can be secured to the side wall of the second hollow
20 organ by suturing with endoscopic assistance.

In still more detailed aspects of the invention, the catheter can be equipped with a corkscrew element adapted to penetrate hold the side wall of the second hollow organ in mating engagement with the severed end of the first
25 hollow organ. A clipping device is described whereby a plurality of clips can be simultaneously applied to the seam between the severed end of the first hollow organ and the side wall of the second hollow organ. In the preferred embodiment, the clips can be applied
30 simultaneously and expeditiously. A gluing device is also described whereby a biocompatible glue can be expeditiously applied along the circumference of the seam

between the severed end of the first hollow organ and the side wall of the second hollow organ.

In an alternative embodiment, a modified cutter catheter having a magnetically susceptible material disposed in proximity to the distal end is utilized in combination with a receiver catheter to perform end-to-side anastomoses. In this embodiment, the receiver catheter includes a magnetic material which can be secured at the proposed site for anastomosis and selectively activated to attract the magnetically susceptible material disposed within the distal end of the modified cutter catheter, thereby facilitating the alignment and engagement of the severed end of the first hollow organ with the side-wall of the second hollow organ at the proposed site for anastomosis. Once the anastomosis has been established, the magnetically susceptible material is released from the modified cutter catheter, and the portion of the side-wall of the second hollow organ removed by the cutter is engaged between the magnetic material and the magnetically susceptible material, preferably within a recess formed in the receiver catheter. The portion of the side-wall removed by the cutter catheter is then be withdrawn from the body along with the receiver catheter.

The method and devices of the present invention find particular application for performing vascular anastomoses, including, in particular, coronary bypass between an arterial source and an obstructed coronary artery. In particular, the method and devices of the present invention find particular application in establishing an anastomoses between the severed end of the

left internal mammary artery ("LIMA") and the side wall of the left anterior descending coronary artery ("LAD").

BRIEF DESCRIPTION OF THE DRAWINGS

5 FIG. 1 is a schematic perspective view of a patient in undergoing a coronary bypass procedure, showing the placement of three surgical trocars and the transluminal approach of a cutter catheter in accordance with the present invention;

10 FIG. 2 is a elevational view of a cutter catheter adapted for use in the coronary bypass procedure shown in FIG. 1;

15 FIG. 3 is a cross-sectional view of the distal end of the cutter catheter shown in FIG. 2 disposed in proximity to the severed end of an arterial source and showing a corkscrew element and a cutter in proximity of the proposed site for anastomosis on the side-wall of a coronary artery;

20 FIG. 4 is a radial cross-sectional view taken along line 4-4 of FIG. 3, showing the distal end of the cutter catheter and the coaxial relationship of the corkscrew element and the cutter;

25 FIG. 5 a cross-sectional view illustrating the position of the clips at the junction between the severed end of the arterial source and the side-wall of the coronary artery after the arterial source has been secured in mating engagement with the side-wall by activation of the corkscrew element;

FIG. 6 a cross-sectional view illustrating the placement of the clips shown in FIG. 5 thereby securing the severed end of the arterial source to the side-wall of the coronary artery;

5 FIG. 7 is a cross-sectional view illustrating activation of the cutter to remove a portion of the side-wall of the coronary artery within the area of securement of the severed end of the arterial source and the coronary artery;

10 FIG. 8 is a perspective view showing the placement of two clipping devices adapted to simultaneously apply a plurality of clips to secure the severed end of the arterial source in sealing engagement with the side wall of the coronary artery;

15 FIG. 9 is a cross-sectional view of the clipping devices shown in FIG. 8 showing the controller utilized in connection with placement and adjustment of a plurality of independently controllable clips thereby securing the severed end of the arterial source to the sidewall of the
20 coronary artery;

FIG. 10 is a perspective view showing the placement of two gluing devices adapted to apply a biocompatible glue to the seam between the severed end of the arterial source and the side-wall of the coronary artery, thereby
25 securing the severed end of the arterial source in sealing engagement with the coronary artery;

FIG. 11 is a cross-sectional view of the gluing devices shown in FIG. 10 showing the controller utilized

in connection with the application of the biocompatible glue;

FIG. 12 is a schematic perspective view of a patient in undergoing a coronary bypass procedure, showing the placement of three surgical trocars and the transluminal approach of a modified cutter catheter disposed in proximity to the severed end of the arterial source and a receiver catheter in accordance with the present invention disposed in proximity to the proposed site for anastomosis in the coronary artery;

FIG. 13 is an elevational view of a modified cutter catheter adapted for use in the coronary bypass procedure shown in FIG. 12;

FIG. 14 is an elevational view of a receiver catheter adapted for use in the coronary bypass procedure shown in FIG. 12 and illustrating a balloon disposed at the distal end in its inflated condition;

FIGS. 15a is a cross-sectional view of the distal end of the modified cutter catheter taken along line 15a-15a of FIG. 13 and FIG. 15b is a cross-sectional view of the receiver catheter taken along line 15b-15b of FIG. 14 wherein the modified cutter catheter is disposed within the arterial source and the distal end of the receiver catheter is disposed within the coronary artery;

FIG. 16 is a radial cross-sectional view taken along line 16-16 of FIG. 15, showing the distal end of the modified cutter catheter and the coaxial relationship of the magnetically susceptible material and the cutter;

FIG. 17 is a bottom view of the distal end of the receiver catheter shown in FIG. 14;

FIG. 18 is a cross-sectional view illustrating alignment of the distal end of the modified cutter catheter of FIG. 13 and the receiver catheter of FIG. 14 and showing the placement of the clipping devices in proximity to the proposed site for anastomosis;

FIG. 19 is a cross-sectional view illustrating the placement of the clips shown in FIG. 18 thereby securing the severed end of the arterial source to the side-wall of the coronary artery;

FIG. 20 is a cross-sectional view illustrating activation of the cutter to remove a portion of the side-wall of the coronary artery within the area of securement of the severed end of the arterial source and the coronary artery; and

FIG. 21 is a cross-sectional view illustrating engagement of the removed portion of the side-wall of the coronary artery between the magnetic material and the magnetically susceptible material within a cavity in the receiver catheter after the magnetically susceptible material has been released from the modified cutter catheter.

DESCRIPTION OF THE PREFERRED EMBODIMENT

25

In preparation for the surgical procedure of the present invention, the patient is placed on the operating table in a supine position, and general anaesthesia administered. The patient is selectively intubated using

conventional methods with a double-lumen endotracheal tube, thereby permitting the left lung to be deflated. The patient is then placed in a lateral decubitus position on his right side. Next, based upon the pathology and anatomy of the patient, the surgeon identifies a suitable position for insertion of a Beress insufflation needle or other suitable needle. Typically, this needle will be inserted between the fifth or sixth intercostal space along the anterior axillary line and into the region between the parietal pleura and the pericardium. The parietal pleura and pericardium are then separated by conventional gas dissection, and the Beress needle is removed.

With reference now to the exemplary drawings, and particularly to FIG. 1, there is shown a schematic perspective view of a patient undergoing an artery-to-artery coronary bypass procedure in accordance with the present invention in which an end-to-side vascular anastomosis is established between the severed end of the left internal mammary artery ("LIMA") 10 and the side-wall of the left anterior descending coronary artery ("LAD") 12 distally to the site of a stenosis. A cutter catheter 14 in accordance with the present invention is disposed within the LIMA 10. The proximal end 14a of the cutter catheter 14 is located outside of the patient and the distal end 14b is located near the severed end of the LIMA.

A first trocar (not shown) and trocar port 16 each having a diameter of approximately 8 to 12 mm and, preferably, 10 mm, are introduced into the thoracic cavity along the same path traveled by the Beress insufflation needle. The trocar is then removed and a conventional

endoscopic telescope (not shown) is introduced through the trocar port 16 into the thoracic cavity. This telescope is used to directly visualize the thoracic cavity and obtain a left lateral view of the heart 18.

5 Based upon (a) direct visualization using the endoscopic telescope; (b) the location of the arterial source (in this case, the LIMA 10), the heart 18 and the coronary artery (in this case, the LAD 12); and (c) the anatomy and pathology of the patient, the surgeon
10 determines a suitable location for insertion of a second trocar (not shown) and trocar port 20 and a third trocar (not shown) and trocar port 22. Typically, however, the second trocar and trocar port 20 will be inserted through the intercostal wall and into the thoracic cavity, and the
15 third trocar and trocar port 22 through the subxyphoid space. Additional trocars or other instruments can be inserted as necessary. Often, it will be advantageous to insert a fourth trocar and trocar port for introducing a clipping or suturing device into the thoracic cavity.

20 Prior to performing the anastomosis, it is also desirable to visualize the coronary artery using conventional angiographic techniques. Typically, the surgeon will already have an angiogram of the affected coronary artery available as a result of the earlier
25 diagnosis of the necessity for the coronary bypass. Similarly, it is desirable to use conventional angiographic techniques to visualize the arterial source. Thus, in the preferred embodiment, the LIMA is visualized using a conventional angiographic LIMA catheter. As a
30 result, as shown in FIG. 1, a standard angiographic LIMA guiding catheter will have been introduced into the femoral artery 24 and advanced under angiographic control

through the aorta and left subclavian artery to the ostium of the LIMA 10.

Under the guidance of the endoscopic telescope, conventional endoscopic instruments are used to isolate the LIMA 10 from surrounding tissue and the chest wall. A number of considerations are taken into account in determining the site for severing the LIMA 10. Using the angiographic and direct visualization, the surgeon can determine a desirable proposed site for severing which will provide a suitable length of artery with a diameter that closely matches that of the coronary artery. A maximum length of the LIMA 10 can be obtained by severing the LIMA 10 at its distal end near the diaphragm. In preparation for severing, blood flow to the side branches of the LIMA 10 is interrupted by clipping or cauterizing the branches of the LIMA proximally of the proposed site for severing. Blood flow through the LIMA 10 is interrupted by applying a first clip on the proximal side of the proposed site for severing and a second clip on the distal side of the proposed site for severing. The LIMA 10 is then severed using conventional endoscopic techniques, thereby creating a proximal severed end and a distal severed end.

Using conventional endoscopic techniques, the parietal pleura is dissected and the pericardial sac is opened. The endoscopic telescope can be used to visualize the LAD 12 while the LAD 12 is then isolated endoscopically from the surrounding tissue proximally and distally of the proposed site for anastomosis.

With reference now to FIG. 2, there is shown a cutter catheter 14 for use in performing vascular anastomoses

which comprises a substantially cylindrical, elongated body **14c** having a proximal end **14a** and a distal end **14b**. The body portion **14c** of the cutter catheter **14** is adapted for introduction into and through the angiographic LIMA guiding catheter (not shown) and into and through the LIMA **10**.

As shown in FIG. 3, the proximal severed end **10a** of the LIMA **10** is then placed in proximity to the proposed site for anastomosis **12a** on the side wall **10a** of the LAD **12** using endoscopic assistance. A cutter catheter **14** in accordance with the present invention has been inserted through the guiding catheter and into the LIMA **10** using a conventional guide wire **28** under angiographic control. The cutter catheter **14** includes a proximal end **14a** which remains outside of the patient and a distal end **14b** which is disposed within the LIMA **10** near the proposed site for severing the LIMA.

As discussed above, insertion of the cutter catheter **14** is accomplished with the assistance of a conventional guide wire **28**. The guide wire **28** and cutter catheter **14** are first inserted into the opening in the proximal end of the angiographic LIMA guiding catheter. The guide wire is then advanced through the angiographic LIMA guiding catheter to the ostium of the LIMA **10**, then further advanced through the LIMA **10** to the clip at the proximal severed end. The cutter catheter **14** is then loaded over the guide wire and the distal end **14b** of the cutter catheter **14** is positioned in proximity to the proximal severed end **10a** of the LIMA **10**. A ligation (not shown) is applied around the exterior of the LIMA **10** and the distal end **14b** of the cutter catheter **14** near the proximal severed end **10a** in order to hold the cutter catheter **14** in

place and also to restrict the flow of fluid once the clip is removed from the proximal severed end 10a. After this ligature is established, the first clip is removed from the proximal severed end 10a.

5 Once these initial preparations have been undertaken, the more detailed aspects of the surgical procedure are initiated. To this end, FIGS. 3-6 depict different stages in the establishment of an end-to-side anastomotic connection in accordance with the present invention. FIG.
10 3 is a cross-sectional view of the distal end 14b of the cutter catheter 14 shown in FIG. 2 disposed in proximity to the proximal severed end 10a of the LIMA 10 and showing a corkscrew element 30 and a cutter 32 contained within the distal end 14b of the body 14c of the cutter catheter
15 14 in proximity to the proximal severed end 10a of the LIMA 10. The proximal severed end 10a of the LIMA 10 is located in a position near the proposed site for anastomosis 26 on the side-wall 12a of the LAD 12.

 As shown in FIG. 3, the distal end 14b of the cutter
20 catheter 14 defines a substantially cylindrical hollow bore 14d. The cutter 32 is disposed within this hollow bore 14d and adapted to extend along and rotate about the longitudinal axis of the cutter catheter 14 beyond the distal end 14b thereby contacting and removing a portion
25 of the side-wall 12a of the LAD 12 at the proposed site for anastomosis 26. Furthermore, the distal end also includes a corkscrew element 30 disposed within the interior of a substantially cylindrical housing 34. The corkscrew element 30 and cylindrical housing 34 are
30 adapted to extend along and rotate about the longitudinal axis of the cutter catheter 14. The corkscrew element 30

may be operated independently from the cylindrical housing
34.

Referring now to FIG. 4, there is shown a radial
cross-sectional view taken along line 4-4 of FIG. 3 of the
5 distal end 14b of the cutter catheter 14 disposed within
the LIMA 10 and placed in proximity to the LAD 12. The
cutter 32 is disposed in substantially coaxial
relationship with the substantially cylindrical hollow
bore 14d near the distal end 14b of the cutter catheter
10 14, and the corkscrew element 30 and cylindrical housing
34, in turn, are also in substantially coaxial
relationship to the bore 14d of the cutter catheter 14.

In the preferred embodiment, the cutter 32 is a
substantially cylindrical hollow body having proximal end
15 32a and a distal end 32b. The distal end 32b of the
cutter 32 includes a sharpened edge or cutting surface
adapted to remove a substantially circular portion of the
side-wall 12a of the LAD 12. Preferably, the length of
the cutter 32 is approximately one-half of the width of
20 the LAD 12 at the proposed site for anastomosis 26, in
order to prevent injury to the opposite wall of the LAD 12
when the cutter 32 is extended into the interior of the
LAD 12.

Movement of the cutter 32 is selectively controlled
25 using a first controller handle 36 located at the proximal
end 14b of the cutter catheter 14. (See, FIG. 2.) The
first control handle 36 and cutter 32 are attached to
opposite ends of a first control conduit 40 disposed
within the body 14c of the cutter catheter 14. By
30 changing the position of the first control handle 36
relative to the proximal end 14a of the cutter catheter

14, the first control conduit 40 is moved longitudinally within the body 14c of the cutter catheter 14 thereby extending the cutter 32. In addition, the first control handle 36 can be rotated thereby rotating the first control conduit 40 and in turn the cutter 32 about the longitudinal axis of the cutter catheter 14. Thus, by combining longitudinal movement and rotation of the first control hand 40, the cutter 32 can be simultaneously extended and rotated, thereby contacting the cutting surface 32b of the cutter 32 with the side-wall 12a of the LAD 12 and extending the cutting surface through the side wall 12a of the LAD 12.

In the preferred embodiment, the corkscrew element 30 is disposed within the cylindrical housing 34, and includes a base 30a, pointed tip 30b adapted to puncture the side-wall 12a of the LAD 12 and a spiral body 30c adapted to be threaded through and engage the side-wall 12a of the LAD 12. Movement of the corkscrew element 30 is selectively controlled using a second controller handle 38 located at the proximal end 14a of the cutter catheter 14. (See, FIG. 2) The second control handle 38 and corkscrew element 30 are attached to opposite ends of a second control wire 42. The control wire is disposed within a control wire conduit 44. By changing the position of the second control handle 38 relative to the proximal end 14a of the cutter catheter 14, the second control wire 42 is moved longitudinally within the control wire conduit body 44 of the cutter catheter 14 thereby extending the corkscrew element 30. Similarly, by changing the position of the control wire conduit 44 relative to the proximal end 14a, the cylindrical housing 34 is moved longitudinally within the distal end 14b of the cutter catheter 14. In addition, the second control

handle 38 can be rotated thereby rotating the second control wire 42 and in turn the corkscrew element 30 about the longitudinal axis of the cutter catheter 14. Thus, by combining longitudinal movement and rotation of the second control handle 38, the corkscrew element 30 can be simultaneously extended and rotated, thereby contacting the pointed tip 30b of the corkscrew element 30 with the side-wall 12a of the LAD 12 and threading the spiral body 30c through the side wall 12a of the LAD 12.

10 Preferably, the length of the corkscrew element 30 is approximately one-half of the width of the LAD, in order to prevent injury to the part of the LAD arterial wall opposite to the point of anastomoses when the corkscrew element is threaded through the side-wall of the LAD.

15 Referring to FIGS. 3 and 5-7, several cross-sectional views are shown illustrating the securement of the proximal severed end 10a of the LIMA 10 to the side-wall 12a of the LAD 12. First, by moving a control wire conduit 44, the cylindrical housing 34 and corkscrew element 30 are moved longitudinally within the distal end 14b of the cutter catheter 14 thereby placing the distal end 34b of the cylindrical housing 34 and tip 30b of the corkscrew element 30 in proximity to the proposed site for anastomosis 26 on the side-wall 12a of the LAD 12.

25 Optionally, the surgeon can aspirate the control wire conduit 44 at the proximal end 14a of the cutter catheter 14, thereby generating an area of negative pressure within the cylindrical housing 34 at the distal end 14b of the cutter catheter 14 and adhering the side-wall 12a of the LAD 12 in mating engagement with the severed end 10a of the LIMA 10 at the proposed site for anastomosis 26.

Thereafter, by combining longitudinal movement and rotation of the second control handle 38, the corkscrew element 30 is extended and rotated so that the pointed tip 30b of the corkscrew element 30 pierces the side-wall 12a of the LAD 12 and the spiral body 30b is threaded through the side wall 12 of the LAD 12 thereby further fixing the proximal severed end 10a in mating engagement with the proposed site for anastomosis 26 on the side wall 12a of the LAD 12. (See FIG. 5.)

Referring to FIGS. 6-7, after the proximal severed end 10a of the LIMA 10 is brought into mating engagement with the site for anastomosis 26 on the side wall 12a of the LAD 12, removable snares (not shown) are applied to the LAD 12 proximally and distally to the proposed site for anastomosis 26 and the LIMA 10 and LAD 12 are secured in sealing engagement using clips 46 and 48 applied along the seam between the proximal severed end 10a of the LIMA 10 and the side wall 12a of the LAD 12, thereby defining a zone of securement between the LIMA 10 and the LAD 12. In particular, it is believed that the surgical clip and applier described in U.S. Patent No. 4,929,240 to Kirsch et al. (incorporated herein by reference) will find ready application in the present method. Alternatively, the anastomosis can be established by other suitable means such as suturing. In the preferred embodiment, however, the distal end 14b of the cutter catheter 14 is sized and shaped to provide support to the severed end 10a of the LIMA 10, so that the clips may be applied without the necessity of everting the tissue at the proposed site for anastomosis 26.

Finally, as shown in FIG. 7, once the LIMA 10 and LAD 12 are secured in sealing engagement, the first controller

handle 36 is activated to extend and rotate the cutter 32, thereby removing a substantially circular portion of the side-wall 12a of the LAD 12 within the area of securement of the proximal severed end 10 of the LIMA 10 and secured
5 by the corkscrew element 30. Thus, the anastomosis is established.

After the side-wall 12 is cut, the first and second control handles are moved thereby retracting the cutter 32 and corkscrew element 30 and the removed portion of the
10 side wall 12a of the LAD 12 within the hollow bore 14d at the distal end 14b of the cutter catheter 14.

As shown in FIGS. 8-9, in the preferred embodiment, the LIMA 10 and LAD 12 are secured in sealing engagement utilizing two clip appliers 50 and 52 that are introduced
15 through the trocar ports 20 and 22 to the proposed site for anastomosis 26. The arcuate edges 50a and 52a of each clip applier are placed along the seam between the proximal severed end 10a of the LIMA 10 and the side wall 12a of the LAD 12. Each clipping device, 50 and 52,
20 includes a plurality of individually operable clips, 46a-f and 48a-f, along its respective arcuate edge, 50a and 52a. Each clip is connected by a clip control wire 54a-f and 56a-f to a controller 58, only one of which is shown. Preferably, the clip appliers 50 and 52 are positioned
25 around the circumference of the seam between the severed end 10a of the LIMA 10 and the side-wall 12a of the LAD 12 whereby each of the clips 46a-f and 48a-f can be simultaneously activated, by activating control button 60, to secure the distal end 10a of the LIMA 10 to the side-
30 wall 12a of the LAD 12. Thereafter, each clip may be individually adjusted utilizing the individual clip controls 62a-f connected to the clip control wires 56a-f.

As discussed above, in the preferred embodiment, the cutter catheter 14 will be sized and shaped to provide support to the LAD as the clips are applied. Thus, it is expected that the clips can be applied without first cutting the side-wall of 12a of the LAD 12 and everting the proximal severed end 10a of the LIMA 10 and the severed edge of the LAD 12. Furthermore, where the surgeon is able to apply the clips simultaneously and thereby expeditiously establish the anastomosis, it is contemplated that the procedure can be performed on the beating heart.

In an alternative embodiment shown in FIGS. 10-11, the LIMA 10 and LAD 12 are secured in sealing engagement utilizing a suitable adherent, such as a biocompatible glue. The glue is applied using two glue applicators 70 and 72 that are introduced through the trocar ports 20 and 22. Each glue applicator 70 and 72, includes a biocompatible glue disposed within channels 70a and 72a formed along each respective arcuate edge 70b and 72b. The glue applicators 70 and 72 are each preferably constructed of a material which is inert to the glue. Each channel 70a and 72a is connected by a glue application control conduit 70c and 72c to a controller, only one of which is shown, controller 74. Preferably, the arcuate edges 70b and 72b of each glue applicator 70 and 72 are placed around the circumference of the seam between the severed end 10a of the LIMA 10 and the side-wall 12a of the LAD 12 whereby the controller for each glue applicator can be simultaneously activated thereby releasing the glue and securing the distal end 10a of the LIMA 10 to the side-wall 12a of the LAD 12.

The glue utilized to secure the severed end of the LIMA to the side wall of the LAD may be any biocompatible glue which gives sufficient strength to secure the severed end of the LIMA in sealing engagement with the side-wall of the LAD. Preferably, the glue is fast acting, so that the region may be secured expeditiously. Examples of such biocompatible glues are the fibrin glue sold under the trade name "TISSEEL" manufactured by Immuno-U.S., Inc. of New York and a gelatin-resorcine-formyl biological glue distributed by Laboratories Cardial.

As discussed in connection with the clipping devices shown in FIGS. 8-9, the distal end **14b** of the cutter catheter **14** is sized and shaped to provide support of the severed end **10a** of the LIMA **10**, thereby facilitating application of the glue. As with the clipping devices shown in FIGS. 8-9, where the glue is fast acting, it is contemplated that the surgeon will be able to establish the anastomosis expeditiously, and, therefore, that the procedure can be performed on the beating heart.

Where the anastomosis is to be performed on the beating heart, it is advantageous to slow the heart to 30-40 beats per minute by the intravenous administration of beta blockers. This slowing of the heart will facilitate securement of the LIMA to the LAD without the necessity of inducing cardiac arrest. Even where it is contemplated that the procedure will be performed on the beating heart, prophylactic measures should be taken so that femoral to femoral cardiopulmonary bypass can be initiated if necessary. Where the method is to be applied to surgery on an arrested heart, preparations should be made for femoral to femoral cardiopulmonary bypass.

Once the anastomosis is established, the ligature around the cutter catheter 14 is released and the cutter catheter 14 is removed along with the portion of the side-wall 12a removed from the LAD 12 and engaged by the corkscrew element 30. The snares can then be removed from the LAD 12. Once an angiographic check of the anastomosis is performed, the guide wire and guiding catheter can be removed. The pericardial sac is then closed and the endoscopic equipment and trocars removed. Finally, any remaining air is aspirated from the thoracic cavity and all incisions closed.

With reference now to FIG. 12, there is shown a schematic perspective view of an alternative embodiment of the present invention. Except as noted below, the patient, LIMA, and LAD are prepared in a manner similar to that described above. In this embodiment, the patient is undergoing an artery-to-artery coronary bypass procedure in which an end-to-side vascular anastomosis is established between the severed end of the LIMA 10 and the side-wall of the LAD 12 distally to the site of a stenosis utilizing a modified cutter catheter 14' disposed within the LIMA 10 in combination with a receiver catheter 100 disposed within the LAD 12. As shown in FIG. 12, the proximal end 14a' of the modified cutter catheter 14' is located outside of the patient and the distal end 14b' is located within the LIMA 10 near the severed end 10a. Similarly, the proximal end 100a of the receiver catheter is located outside the patient while the distal end 100b is located inside the LAD 12 near the proposed site for anastomosis. More detailed aspects of the modified cutter catheter and the receiver catheter are shown in FIGS. 13 and 14, respectively.

With reference now to FIGS. 13-15, there is shown a modified cutter catheter 14' for use in performing vascular anastomoses which includes a substantially cylindrical, elongated body 14c' having a proximal end 14a' and a distal end 14b'. The body portion 14c' and distal end 14b' of the modified cutter catheter 14' are adapted for introduction into and through the angiographic LIMA guiding catheter and into and through the LIMA 10 with the assistance of a guide wire. As shown in partial cross-section in FIG. 15a, the modified cutter catheter 14' further comprises a cutter 32' and a magnetically susceptible material 30' disposed within the distal end 14b'. The modified cutter catheter 14' includes a first control handle 36' and a second control handle 38' which are adapted to control the cutter 32' and the magnetically susceptible material 30', respectively.

Referring further now to FIG. 14, more detailed aspects of the receiver catheter are illustrated. The receiver catheter 100 includes a substantially cylindrical, elongated body 100c having a proximal end 100a and a distal end 100b. The distal end 100b of the receiver catheter includes a selectively inflatable balloon 102, shown in its inflated condition, and a receiver 104. The body portion 100c, balloon 102, and receiver 104 of the receiver catheter 100 are adapted to be introduced into and through a conventional coronary guiding catheter and into and through the LAD 12 up to the proposed site for anastomosis with the assistance of a guide wire.

Referring further now to FIGS. 15a and 15b, there is shown a cross-sectional view of the distal end 14b' of the modified cutter catheter 14' taken along line 15a-15a of

FIG. 13 and also of the distal end **100b** of the receiver catheter **100** taken along the line 15b-15b of FIG 14. As shown in FIG. 15a, the distal end **14b'** of the modified cutter catheter **14'** defines a substantially cylindrical hollow bore **14d'**. The cutter **32'** is disposed in substantially coaxial relationship with the substantially cylindrical hollow bore **14d'** near the distal end **14b'** of the modified cutter catheter **14'**. The cutter **32'** is adapted to extend along and rotate about the longitudinal axis of the modified cutter catheter **14'** beyond the distal end **14b'** thereby contacting and removing a portion of the side-wall **12a** of the LAD **12** at the proposed site for anastomosis **26**. The modified cutter catheter also includes the substantially cylindrical magnetically susceptible material **30'** contained within the interior of the cutter **32'** in the distal end **14b'** of the modified cutter catheter **14'**. Meanwhile, the receiver catheter **100** is disposed within the coronary artery **12**. The receiver cavity **104c** is disposed in proximity to the proposed site for anastomosis **26** whereby, when the balloon **102** is inflated, the receiver cavity **104c** is secured within the coronary artery **12** in alignment with the proposed site for anastomosis **12a**.

As shown in partial cross-section in FIG. 15b, the receiver **104** is preferably a cup-like structure having a substantially cylindrical side-wall **104a** and a base **104b** which define a cavity **104c**. A selectively activatable magnetic material **106** is disposed within the inner portion of the receiver cavity **104c** near the base **104b**. The balloon **102** is adapted, upon inflation, to restrict the flow of fluid through the LAD **12** and to secure the distal end **100b** of the receiver catheter **100** in the interior of

the LAD 12 whereby the receiver cavity 104c may be positioned in proximity to, and aligned with the proposed site for anastomosis of the coronary artery. The magnetic material 106 of the receiver catheter 100 is adapted to
5 selectively engage the magnetically susceptible material 30' of the modified cutter catheter 14' once the distal end 14b' of the receiver catheter 14' has been positioned in proximity to the proposed site for anastomosis. Thus, the attractive force between the magnetic material and the
10 magnetically susceptible material advantageously facilitates positioning and engagement of the severed end of the LIMA with the side-wall of the LAD at the proposed site for anastomosis.

Referring now to FIG. 16, there is shown a radial-cross-sectional view taken along line 16-16 of FIG. 15 of
15 the distal end 14b' of the modified cutter catheter 14' disposed within the LIMA 10. The cutter 32' is disposed in substantially coaxial relationship with the substantially cylindrical hollow bore 14d' near the distal
20 end 14b' of the modified cutter catheter 14', and the magnetically susceptible material 30' is also disposed in substantially coaxial relationship to the bore 14d' of the modified cutter catheter 14'.

Referring now to FIG. 17, there is shown a bottom
25 view of the receiver catheter including the cylindrical sidewall 104a that defines the receiver cavity 104c.

As with the embodiments discussed previously, the cutter 32' is a substantial cylindrical hollow body having proximal end 32a' and a distal end 32b'. The
30 distal end 32b' of the cutter 32' includes a sharpened edge or cutting surface adapted to remove a substantially

circular portion 12b of the side-wall 12a of the LAD 12. Preferably, the diameter and length of the cutter 32' are selected so that the sharpened edge of the cutter 32' may extend into the cavity 104c of the receiver 104 when the cutter 32' is activated. Movement of the cutter 32' is selectively controlled as in the previously described embodiments by using a first controller handle 36' located at the proximal end 14a' of the modified cutter catheter 14'.

10 The modified cutter catheter 14' also includes the substantially cylindrical magnetically susceptible material 30', disposed within the interior of the cutter 32'. The magnetically susceptible material 30' is adapted to be inserted into the cavity 104c in the receiver
15 catheter 100. Movement of the magnetically susceptible material 30' is selectively controlled using the second controller handle 38' located at the proximal end 14a' of the modified cutter catheter 14'. The second control handle 38' and magnetically susceptible material 30' are
20 attached to opposite ends of a control wire 42'. The control wire 42' is disposed within the control conduit 40'. By changing the position of the second control handle 38' relative to the proximal end 14a' of the modified cutter catheter 14', the control wire 42' is
25 moved longitudinally within the control conduit 40' of the modified cutter catheter 14' thereby extending the magnetically susceptible material 30'. In addition, the second control handle 38' can be rotated thereby rotating the control wire 42' about the longitudinal axis of the
30 cutter catheter 14. The control wire 42' is advantageously threadingly inserted into the magnetically susceptible material 30' whereby counterclockwise rotation

of the control wire 42' releases the magnetically susceptible material 30' from the control wire 42'.

5 Preferably, the length of outer surface of the magnetically susceptible material 30' is approximately one-half of the depth of the cavity 104c of the receiver 104 in order to permit the magnetically susceptible material 30' and the portion of the side-wall 12b of the LAD removed by the cutter to both be held within the interior of the cavity 104c in the distal end 100b of the receiver catheter 100.

15 As with the embodiments described previously and shown in FIG. 12, in the practice of the invention, the modified cutter catheter 14' is inserted into and through a guiding LIMA catheter and into and through the LIMA 10 using a conventional guide wire under angiographic control. A ligation is applied around the exterior of the LIMA 10 and the distal end 14b' of the modified cutter catheter 14' near the proximal severed end 10a in order to secure the modified cutter catheter 14' in place and also 20 to restrict the flow of fluid once the clip is removed from the proximal severed end 10a. After this ligature is established, the first clip is removed from the proximal severed end 10a.

25 The receiver catheter 100 is also inserted with the assistance of a conventional angiographic coronary guiding catheter and guide wire. As shown in FIG. 12, the angiographic coronary catheter is advanced through the femoral artery to the ascending aorta and then to the left coronary ostium. Thereafter, the guide wire and receiver catheter 100 are inserted into an opening in the proximal 30 end of the angiographic coronary guiding catheter. The

guide wire is advanced through the angiographic coronary guiding catheter to the ostium of the left coronary artery and into the LAD under angiographic control. The receiver catheter 100 is then loaded over the guide wire 108 and the distal end 100b of the receiver catheter 100 is positioned in proximity to the proposed site for anastomosis 26 in the LAD 12.

As shown in FIG. 15b, after the distal end 100b of the receiver catheter 100 is positioned, the receiver cavity 104c and magnetic material 106 are oriented at the proposed site for anastomosis 26 and the balloon 102 is inflated, whereby the balloon 102 engages the sidewall 12a of the LAD 12, thereby securing the distal end 100b of the receiver catheter 100 within the LAD 12 and placing the receiver cavity 104c in alignment with the proposed site for anastomosis 26. Alternatively, the receiver catheter can be secured by any suitable means, such as a ligation applied around the exterior of the LAD 12. It will also be appreciated that the balloon 102 on the receiver catheter 100 can be adapted to perform a conventional balloon angioplasty at the site of a stenosis in the coronary artery.

Once these initial preparations have been undertaken, more detailed aspects of the surgical procedure are initiated. To this end, FIGS. 18-21 depict different stages in the establishment of an end-to-side anastomotic connection in accordance with the present invention.

As shown in FIG. 18, after the distal end 100b of the receiver catheter 100 is loaded over the guide wire 108 and secured within the LAD 12, the severed end 10a of the LIMA 10 is manipulated with endoscopic assistance in

proximity to the proposed site for anastomosis. By moving the control wire 42', the magnetically susceptible material 30' is moved longitudinally within the distal end 14b' of the cutter catheter 14' thereby placing the tip of the magnetically susceptible material 30' in proximity to the proposed site for anastomosis 26 on the side-wall 12a of the LAD 12. The magnetic material 106 in the receiver catheter 100 is activated by the application of an electromagnetic force through wires (not shown) connected to the magnetic material. The resulting attractive force between the magnetically susceptible material 30' of the modified cutter catheter 14' and the magnetic material 106 of the receiver catheter 100 facilitates engagement and alignment of the severed end 10a of the LIMA 10 with the side-wall 12a of the LAD 12 at the proposed site for anastomosis 26, as illustrated in FIG. 18.

The magnetic material 106 is preferably constructed of a selectively activatable magnetic material that can be controlled by the application of an electromagnetic force. Examples of such materials are sintered neodymium-iron-boron magnets which can be obtained from Magnet Sales and Manufacturing Inc. of Culver City. The magnetically susceptible material 30' can be a metal such as a composite metal containing iron which would be attracted to the magnetic material 106. Alternatively, the magnetically susceptible material can also be constructed of a magnetic material which can also be selectively activated to engage the magnetic material 106 in the receiver. It will be appreciated that variations of the materials and arrangements of the magnetically susceptible material are within the ordinary skill in the art. In particular, it will be appreciated that the magnetic material and magnetically susceptible material could both

be constructed of conventional magnetic materials, which, when placed in the proper orientation experience an attractive force. Similarly, the locations of the magnetically susceptible material 30' and the magnetic material 106 could be reversed, with the magnetic material 106 located in the distal end of the modified cutter catheter 14' and the magnetically susceptible material 30' in the distal end of the receiver catheter 100. Alternatively, conventional magnets can be utilized in both the modified cutter catheter 14' and the receiver catheter 100. It will also be observed that modifications could be made to the size and shape of the magnetically susceptible material 30' and receiver cavity 104c in accordance with the teachings of the present invention.

As shown in FIG. 19, after the LIMA 10 and LAD 12 are brought into engagement, they may be secured in sealing engagement utilizing the clipping appliers 46 and 48 described above. Preferably, where clipping is contemplated, the distal end 14b' of the modified cutter catheter 14' and the distal end of the receiver catheter are sized and shaped to provide support to the severed end 10a of the LIMA 10 and the LAD 12, respectively, to facilitate application of the clips. It will be appreciated, however, that the LIMA 10 and LAD may be secured by any suitable means, including the gluing system described above.

Finally, as shown in FIG. 20, once the LIMA 10 and LAD 12 are secured in sealing engagement, the first controller handle 36' is activated to extend and rotate the cutter 32', thereby removing a substantially circular portion 12b of the side-wall 12a of the LAD 12 within the

area of securement of the proximal severed end 10 of the LIMA 10, thereby establishing the anastomosis.

As shown in FIG. 21, after the substantially circular portion 12b of the side-wall 12a of the LAD 12 is cut, the cutter 32' is retracted and the second control handle is advanced longitudinally, advancing the magnetically susceptible material 30' into the receiver cavity 104c whereby the substantially circular portion 12b of the side wall 12a of the LAD 12 is engaged within the cavity 100c at the distal end 14b' of the receiver catheter 100 between the magnetically susceptible material 30' and the magnetic material 106. The second control handle 38' is then rotated, whereby the control wire 42' is unthreaded from the base 30a' of the magnetically susceptible material 30', thereby disengaging the magnetically susceptible material 30' from the modified cutter catheter 14'.

Once the anastomosis is established, the control wire 42' is retracted. As a result of the attractive forces between the magnetic material 106 and the magnetically susceptible material 30', the magnetically susceptible material 30' is held within the cavity 104c of the receiver 104, thereby engaging the substantially circular portion 12b of the side wall 12a of the LAD 12 removed by the cutter 32'. The balloon 102 on the distal end 100b of the receiver catheter 100 is deflated and the receiver catheter 100 is removed along with the portion 12b of the side-wall 12a removed from the LAD 12 and the magnetically susceptible material 30' disengaged from the cutter catheter 14'. Once an angiographic check of the anastomosis is performed, the guide wire and guiding catheter can be removed. The pericardial sac is then

closed and the endoscopic equipment and trocars removed. Finally, any remaining air is aspirated from the thoracic cavity and all incisions closed.

As discussed above in connection with the preferred
5 embodiment, the modified cutter catheter 14' will be sized
and shaped to provide support to the LAD as the clips or
glue or glue is applied. Thus, it is expected that the
clips can be applied without first cutting the side-wall
of 12a of the LAD 12 and everting the proximal severed end
10 10a of the LIMA 10 and the severed edge of the LAD 12.
Furthermore, where the surgeon is able to apply the clips
or glue simultaneously and thereby expeditiously establish
the anastomosis, it is contemplated that the procedure can
be performed on the beating heart.

15 Although a particular form of the invention has been
illustrated and described, it will be appreciated by those
skilled in the art that various modifications can be made
without departing from the spirit and scope of the
invention. Accordingly, the scope of the present
20 invention is not to be limited by the particular
embodiments above, but is to be defined only by the
following claims.

WE CLAIM:

1. A method for establishing an end-to-side anastomosis between a severed end of a first hollow organ and a side-wall of a second hollow organ, the method
5 comprising:

(a) introducing a catheter, having proximal and distal ends, into the first hollow organ and passing the catheter through the first organ until the distal end of the catheter is substantially adjacent to the severed end
10 of the first hollow organ, the catheter having a selectively operable cutter adapted to remove a portion of the side-wall of the second hollow organ;

(b) positioning the severed end of the first hollow organ in proximity with the site for anastomosis of
15 the second hollow organ;

(c) securing the severed end of the first hollow organ in sealing engagement with the side-wall of the second hollow organ, thereby defining a region of securement on a side-wall of the second hollow organ; and
20

(d) activating the cutter to remove a portion of a side-wall of the second hollow organ thereby creating an opening within the region of securement defined by the engagement of the severed end of the first hollow organ with the side-wall of the second hollow organ.

25 2. The method of claim 1, wherein the first and second hollow organs are both vascular lumens.

3. The method of claim 1, wherein the first hollow organ is the left internal mammary artery and the second hollow organ is a coronary artery.

30 4. The method of claim 1, wherein the method further includes:

generating an area of negative pressure in the interior of the catheter near the severed end, thereby engaging the side-wall of the coronary artery with the severed end of the LIMA.

5 5. The method of claim 1, wherein the securing of the severed end of the first hollow organ in sealing engagement with the side-wall of the second hollow organ, includes stapling the first hollow organ to the sidewall of the second hollow organ.

10 6. A method for performing end-to-side anastomosis between a severed end of a first hollow organ and a side-wall of a second hollow organ, the method comprising:

 (a) introducing a catheter, having proximal and distal ends, into the first hollow organ and passing the
15 catheter through the first organ until the distal end of the catheter is substantially adjacent to the severed end of the first hollow organ, the catheter having a corkscrew element and a selectively operable cutter adapted to remove a portion of the side-wall of the second hollow
20 organ;

 (b) positioning the severed end of the first hollow organ in proximity with the site for anastomosis of the second hollow organ;

 (c) activating the corkscrew element whereby
25 corkscrew element penetrates the side wall of the severed hollow organ and the severed end of the first hollow organ is held in mating relationship with the second hollow organ;

 (d) securing the severed end of the first
30 hollow organ in sealing engagement with the side-wall of the second hollow organ, thereby defining a region of securement on a side-wall of the second hollow organ; and

 (e) activating the cutter to remove a portion of a side-wall of the second hollow organ thereby creating

an opening within a region of securement defined by the engagement of the severed end of the first hollow organ with the side-wall of the second hollow organ.

5 7. The method of claim 6, wherein the first and second hollow organs are both vascular lumens.

8. The method of claim 6, wherein the first hollow organ is the left internal mammary artery and the second hollow organ is a coronary artery.

10 9. The method of claim 6, wherein the method further includes:

generating an area of negative pressure in the interior of the catheter near the severed end, thereby engaging the side-wall of the coronary artery with the severed end of the LIMA.

15 10. The method of claim 6, wherein the securing of the severed end of the first hollow organ in sealing engagement with the side-wall of the second hollow organ, includes stapling the first hollow organ to the side-wall of the second hollow organ.

20 11. A catheter for performing an end-to-side anastomosis between a severed end of a first hollow organ and a side-wall of a second hollow organ of a patient, comprising:

25 an elongated body having proximal and distal ends and adapted for introduction into and through the first hollow organ; and

30 a selectively operable cutter disposed within the body and having a cutting surface at the distal end which is configured to remove a portion of a side-wall of the second hollow organ.

12. The catheter of claim 11, wherein the distal end of the catheter defines a bore having an aperture in the distal end of the catheter and the cutter is disposed within the bore.

5 13. The catheter of claim 11, wherein the cutter includes:

an elongated cutter body disposed axially within the elongated catheter body and extendable along a longitudinal axis of the elongated catheter body; and

10 a cutting element associated with the elongated cutter body and configured for engagement with the second hollow organ.

14. The catheter of claim 13, wherein the catheter further includes a controller adapted to control the
15 cutter.

15. The catheter of claim 11, wherein the catheter further includes a corkscrew element adapted to engage the side-wall of second hollow organ whereby the severed end of the first hollow organ is held in mating engagement
20 with the side-wall of the second hollow organ.

16. The catheter of claim 11, wherein the catheter further includes a controller adapted to control the corkscrew element.

17. The catheter of claim 16, wherein the controller
25 includes a control wire disposed within the elongated body and movable along the longitudinal axis of the body of the catheter, the control wire further being connected to a control handle at the proximal end of the catheter and to the at the distal end of the catheter.

18. The catheter of claim 11, wherein the proximate end of the catheter includes a first controller adapted to control the corkscrew element and a second controller adapted to control the cutter.

5 19. A method for establishing an end-to-side anastomosis between a severed end of a first hollow organ and a side-wall of a second hollow organ, the method comprising:

10 (a) introducing a catheter, having proximal and distal ends, into the first hollow organ and passing the catheter through the first organ until the distal end of the catheter is substantially adjacent to the severed end of the first hollow organ, the catheter having a selectively operable cutter adapted to remove a portion of
15 the side-wall of the second hollow organ;

(b) positioning the severed end of the first hollow organ in proximity with the site for anastomosis of the second hollow organ;

20 (c) adhering the severed end of the first hollow organ to the side-wall of the second hollow organ, thereby defining a region of securement on a side-wall of the second hollow organ; and

25 (d) activating the cutter to remove a portion of a side-wall of the second hollow organ thereby creating an opening within the region of securement defined by the engagement of the severed end of the first hollow organ with the side-wall of the second hollow organ.

20. The method of claim 19, wherein the first and second hollow organs are both vascular lumens.

30 21. The method of claim 19, wherein the first hollow organ is the left internal mammary artery and the second hollow organ is a coronary artery.

22. The method of claim 19, wherein the adhering of the severed end of the first hollow organ is effectuated by applying a biocompatible glue.

23. A method for establishing an end-to-side anastomosis between a severed end of a first hollow organ and a side-wall of a second hollow organ, the method comprising:

(a) introducing a first catheter, having proximal and distal ends, into the first hollow organ and passing the first catheter through the first hollow organ until the distal end of the first catheter is substantially adjacent to the severed end of the first hollow organ, wherein the first catheter includes a selectively operable cutter, adapted to remove a portion of the side-wall of the second hollow organ, and a magnetically susceptible material disposed near the distal end of the first catheter;

(b) introducing a second catheter, having proximal and distal ends, into the second hollow organ and passing the second catheter through the second hollow organ until the distal end of the second catheter is substantially adjacent to the proposed site for anastomosis, wherein the second catheter includes a magnetic material disposed near the distal end of the second catheter;

(c) positioning the severed end of the first hollow organ in proximity to the proposed site for anastomosis and thereby placing the magnetically susceptible material in proximity to the magnetic material whereby the magnetic material engages the magnetically susceptible material, and the severed end of the first hollow organ engages the side-wall of the second hollow organ at the site for anastomosis;

(d) securing the severed end of the first hollow organ in sealing engagement with the side-wall of

the second hollow organ, thereby defining a region of securement on a side-wall of the second hollow organ; and

5 (e) activating the cutter to remove a portion of a side-wall of the second hollow organ thereby creating an opening within the region of securement defined by the engagement of the severed end of the first hollow organ with the side-wall of the second hollow organ.

24. The method of claim 23, wherein the first and second hollow organs are both vascular lumens.

10 25. The method of claim 23, wherein the first hollow organ is the left internal mammary artery and the second hollow organ is a coronary artery.

15 26. The method of claim 23, wherein the magnetic material used to engage the magnetically susceptible material is selectively activatable.

27. The method of claim 26, wherein the selectively activatable magnetic material used to engage the magnetically susceptible material comprises neodymium-iron-boron.

20 28. The method of claim 23, wherein the securing of the severed end of the first hollow organ in sealing engagement with the side-wall of the second hollow organ, includes adhering the first hollow organ to the sidewall of the second hollow organ.

25 29. The method of claim 28, wherein securing the severed end of the first hollow organ in sealing engagement with the side wall of the second hollow organ is effected with a biocompatible glue.

30. The method of claim 23, wherein the securing of the severed end of the first hollow organ in sealing engagement with the side-wall of the second hollow organ, includes stapling the first hollow organ to the sidewall
5 of the second hollow organ.

31. The method of claim 23, wherein the securing of the severed end of the first hollow organ in sealing engagement with the side-wall of the second hollow organ, includes suturing the first hollow organ to the sidewall
10 of the second hollow organ.

32. The method of claim 23, wherein the second catheter further includes a means for securing the distal end of the second catheter within the second hollow organ near the proposed site for anastomosis.

15 33. The method of claim 32, wherein the means for securing the distal end of the second catheter within the second hollow organ near the proposed site for anastomosis is a balloon adapted to engage the side walls of the second hollow organ.

20 34. A method for establishing an end-to-side anastomosis between a severed end of a first hollow organ and a side-wall of a second hollow organ, the method comprising:

(a) introducing a first catheter, having
25 proximal and distal ends, into the first hollow organ and passing the first catheter through the first hollow organ until the distal end of the first catheter is substantially adjacent to the severed end of the first hollow organ, wherein the first catheter includes a
30 selectively operable cutter, adapted to remove a portion of the side-wall of the second hollow organ, and a

magnetic material disposed near the distal end of the first catheter;

5 (b) introducing a second catheter, having proximal and distal ends, into the second hollow organ and passing the second catheter through the second hollow organ until the distal end of the second catheter is substantially adjacent to the proposed site for anastomosis, wherein the second catheter includes a magnetically susceptible material disposed near the distal
10 end of the second catheter;

(c) positioning the severed end of the first hollow organ in proximity to the proposed site for anastomosis and thereby placing the magnetic material in proximity to the magnetically susceptible material,
15 whereby the magnetic material engages the magnetically susceptible material, and the severed end of the first hollow organ engages the side-wall of the second hollow organ at the site for anastomosis;

(d) securing the severed end of the first
20 hollow organ in sealing engagement with the side-wall of the second hollow organ, thereby defining a region of securement on a side-wall of the second hollow organ; and

(e) activating the cutter to remove a portion
25 of a side-wall of the second hollow organ thereby creating an opening within the region of securement defined by the engagement of the severed end of the first hollow organ with the side-wall of the second hollow organ.

35. The method of claim 34, wherein the first and second hollow organs are both vascular lumens.

30 36. The method of claim 34, wherein the first hollow organ is the left internal mammary artery and the second hollow organ is a coronary artery.

37. The method of claim 34, wherein the magnetic material used to engage the magnetically susceptible material is selectively activatable.

38. The method of claim 37, wherein the selectively
5 activatable magnetic material used to engage the magnetically susceptible material comprises neodymium-iron-boron.

39. The method of claim 34, wherein the securing of
10 the severed end of the first hollow organ in sealing engagement with the side-wall of the second hollow organ, includes adhering the first hollow organ to the sidewall of the second hollow organ.

40. The method of claim 39, wherein securing the
15 severed of the first hollow organ in sealing engagement with the side wall of the second hollow organ is effected with a biocompatible glue.

41. The method of claim 34, wherein the securing of
20 the severed end of the first hollow organ in sealing engagement with the side-wall of the second hollow organ, includes stapling the first hollow organ to the sidewall of the second hollow organ.

42. The method of claim 34, wherein the securing of
25 the severed end of the first hollow organ in sealing engagement with the side-wall of the second hollow organ, includes suturing the first hollow organ to the sidewall of the second hollow organ.

43. A method for establishing an end-to-side
30 anastomosis between a severed end of a first hollow organ and a side-wall of a second hollow organ, the method comprising:

(a) introducing a first catheter, having proximal and distal ends, into the first hollow organ and passing the first catheter through the first hollow organ until the distal end of the first catheter is substantially adjacent to the severed end of the first hollow organ, wherein the first catheter includes a selectively operable cutter adapted to remove a portion of the side-wall of the second hollow organ and a releasable magnetically susceptible material disposed near the distal end;

(b) introducing a second catheter, having proximal and distal ends, into the second hollow organ and passing the second catheter through the second hollow organ until the distal end of the second catheter is substantially adjacent to the proposed site for anastomosis, wherein the second catheter includes a magnetic material disposed near the distal end of the second catheter and a cavity formed in the distal end of the catheter configured to receive the releasable magnetically susceptible material of the first catheter;

(c) positioning the severed end of the first hollow organ in proximity to the proposed site for anastomosis and thereby placing the magnetically susceptible material in proximity to the magnetic material, whereby the magnetically susceptible material engages the magnetic material, and the severed end of the first hollow organ engages the side-wall of the second hollow organ at the site for anastomosis;

(d) securing the severed end of the first hollow organ in sealing engagement with the side-wall of the second hollow organ, thereby defining a region of securement on a side-wall of the second hollow organ;

(e) activating the cutter to remove a portion of a side-wall of the second hollow organ thereby creating an opening within the region of securement defined by the

engagement of the severed end of the first hollow organ with the side-wall of the second hollow organ; and

(f) releasing the releasable magnetically susceptible material of the first catheter whereby the
5 portion of the side-wall of the second hollow organ removed by activation of the cutter is engaged between the magnetically susceptible material from the first catheter and the magnetic material of the second catheter within the cavity in the distal end of the second hollow organ.

10 44. The method of claim 43, wherein the second catheter further includes means for securing the distal end of the second catheter within the second hollow organ near the proposed site for anastomosis.

15 45. The method of claim 44, wherein the means for securing the distal end of the second catheter within the second hollow organ near the proposed site for anastomosis is an inflatable balloon adapted to engage the side walls of the second hollow organ.

20 46. A method for establishing an end-to-side anastomosis between a severed end of a first hollow organ and a side-wall of a second hollow organ, the method comprising:

(a) introducing a first catheter, having proximal and distal ends, into the first hollow organ and
25 passing the first catheter through the first hollow organ until the distal end of the first catheter is substantially adjacent to the severed end of the first hollow organ, wherein the first catheter includes a selectively operable cutter adapted to remove a portion of
30 the side-wall of the second hollow organ and a releasable magnetic material disposed near the distal end;

(b) introducing a second catheter, having proximal and distal ends, into the second hollow organ and

passing the second catheter through the second hollow organ until the distal end of the second catheter is substantially adjacent to the proposed site for anastomosis, wherein the second catheter includes a magnetically susceptible material disposed near the distal end of the second catheter and a cavity formed in the distal end of the catheter configured to receive the releasable magnetically susceptible material of the first catheter;

5
10 (c) positioning the severed end of the first hollow organ in proximity to the proposed site for anastomosis thereby placing the magnetic material in proximity to the magnetically susceptible material whereby the magnetic material engages the magnetically susceptible material, thereby engaging the severed end of the first hollow organ with the side-wall of the second hollow organ at the site for anastomosis;

15
20 (d) securing the severed end of the first hollow organ in sealing engagement with the side-wall of the second hollow organ, thereby defining a region of securement on a side-wall of the second hollow organ;

(e) activating the cutter to remove a portion of a side-wall of the second hollow organ thereby creating an opening within the region of securement defined by the engagement of the severed end of the first hollow organ with the side-wall of the second hollow organ; and

25
30 (f) releasing the releasable magnetically susceptible material of the first catheter whereby the portion of the side-wall of the second hollow organ removed by activation of the cutter is engaged between the magnetically susceptible material from the first catheter and the magnetic material of the second catheter within the cavity in the distal end of the second hollow organ.

47. The method of claim 46, wherein the second catheter further includes a means for securing the distal

35

end of the second catheter within the second hollow organ near the proposed site for anastomosis.

48. The method of claim 47, wherein the means for securing the distal end of the second catheter within the second hollow organ near the proposed site for anastomosis is a balloon adapted to engage the side walls of the second hollow organ.

49. A catheter for performing an end-to-side anastomosis between a severed end of a first hollow organ and a side-wall of a second hollow organ of a patient, comprising:

an elongated body having proximal and distal ends and adapted for introduction into and through the first hollow organ;

a selectively operable cutter disposed within the body and having a cutting surface at the distal end which is configured to remove a portion of a side-wall of the second hollow organ; and

a magnetically susceptible material disposed within the body wherein the magnetically susceptible material is adapted to engage a magnetic material disposed within the second hollow organ in proximity to the proposed site for anastomosis whereby the severed end of the first hollow organ is held in mating engagement with the side-wall of the second hollow organ.

50. The catheter of claim 49, wherein the distal end of the catheter defines a bore having an aperture in the distal end of the catheter and the cutter and the magnetically susceptible material are disposed within the bore.

51. The catheter of claim 49, wherein the cutter includes:

an elongated cutter body disposed axially within the elongated catheter body and extendable along a longitudinal axis of the elongated catheter body; and

5 a cutting element associated with the elongated cutter body and configured for engagement with the second hollow organ.

52. The catheter of claim 51, wherein the catheter further includes a controller adapted to control the cutter.

10 53. The catheter of claim 49, wherein the catheter further includes a controller adapted to control the magnetically susceptible material.

54. The catheter of claim 49, wherein the proximate end of the catheter includes a first controller adapted to control the magnetically susceptible material and a second controller adapted to control the cutter.

55. A system for performing an end-to-side anastomosis between a severed end of a first hollow organ and a side-wall of a second hollow organ of a patient, comprising:

a first catheter, including

(a) a first elongated body having proximal and distal ends and configured for insertion within the first hollow organ;

25 (b) a selectively operable cutter disposed within the body and having a cutting surface at the distal end which is configured to remove a portion of a side-wall of the second hollow organ, and

(c) a magnetically susceptible material disposed within the first elongated body; and

30 a second catheter, including

(d) a second elongated body having proximal and distal ends and configured for insertion within the second hollow organ, and

5 (e) a magnetic material associated with the second elongated body.

10 56. The system of claim 55, wherein the distal end of the first catheter defines a bore having an aperture in the distal end of the catheter and the cutter and the magnetically susceptible material are disposed within the bore.

57. The system of claim 55, wherein the cutter includes:

15 an elongated cutter body disposed axially within the elongated catheter body and extendable along a longitudinal axis of the elongated catheter body; and

a cutting element associated with the elongated cutter body and configured for engagement with the second hollow organ.

20 58. The system of claim 57, wherein the first catheter further includes a controller adapted to control the cutter.

59. The system of claim 55, wherein the first catheter further includes a controller adapted to control the magnetically susceptible material.

25 60. The system of claim 59, wherein the second catheter further includes an inflatable balloon attached to the distal end of the catheter, the balloon defining a cavity within which the magnetic material is disposed.

61. The system of claim 59, wherein magnetic material used to engage the magnetically susceptible material is selectively activatable.

5 62. The system of claim 56, wherein the selectively activatable magnetic material used to engage the magnetically susceptible material comprises neodymium-iron-boron.

10 63. A system for performing an end-to-side anastomosis between a severed end of a first hollow organ and a side-wall of a second hollow organ of a patient, comprising:

a first catheter, including

15 (a) a first elongated body having proximal and distal ends and configured for insertion within the first hollow organ;

(b) a selectively operable cutter disposed within the body and having a cutting surface at the distal end which is configured to remove a portion of a side-wall of the second hollow organ, and

20 (c) a magnetic material disposed within the first elongated body; and

a second catheter, including

25 (d) a second elongated body having proximal and distal ends and configured for insertion within the second hollow organ, and

(e) a magnetically susceptible material associated with the second elongated body.

30 64. The system of claim 63, wherein the distal end of the first catheter defines a bore having an aperture in the distal end of the catheter and the cutter and the magnetic material are disposed within the bore.

65. The system of claim 63, wherein the cutter includes:

an elongated cutter body disposed axially within the elongated catheter body and extendable along a longitudinal axis of the elongated catheter body; and

a cutting element associated with the elongated cutter body and configured for engagement with the second hollow organ.

66. The system of claim 65, wherein the first catheter further includes a controller adapted to control the cutter.

67. The system of claim 63, wherein the first catheter further includes a controller adapted to control the magnetic material.

68. The system of claim 67, wherein the second catheter further includes an inflatable balloon attached to the distal end of the catheter, the balloon defining a cavity within which the magnetically susceptible material is disposed.

69. The system of claim 67, wherein the magnetic material used to engage the magnetically susceptible material is selectively activatable.

70. The system of claim 67, wherein the selectively activatable magnetic material used to engage the magnetically susceptible material comprises neodymium-iron-boron.

FIG. 1

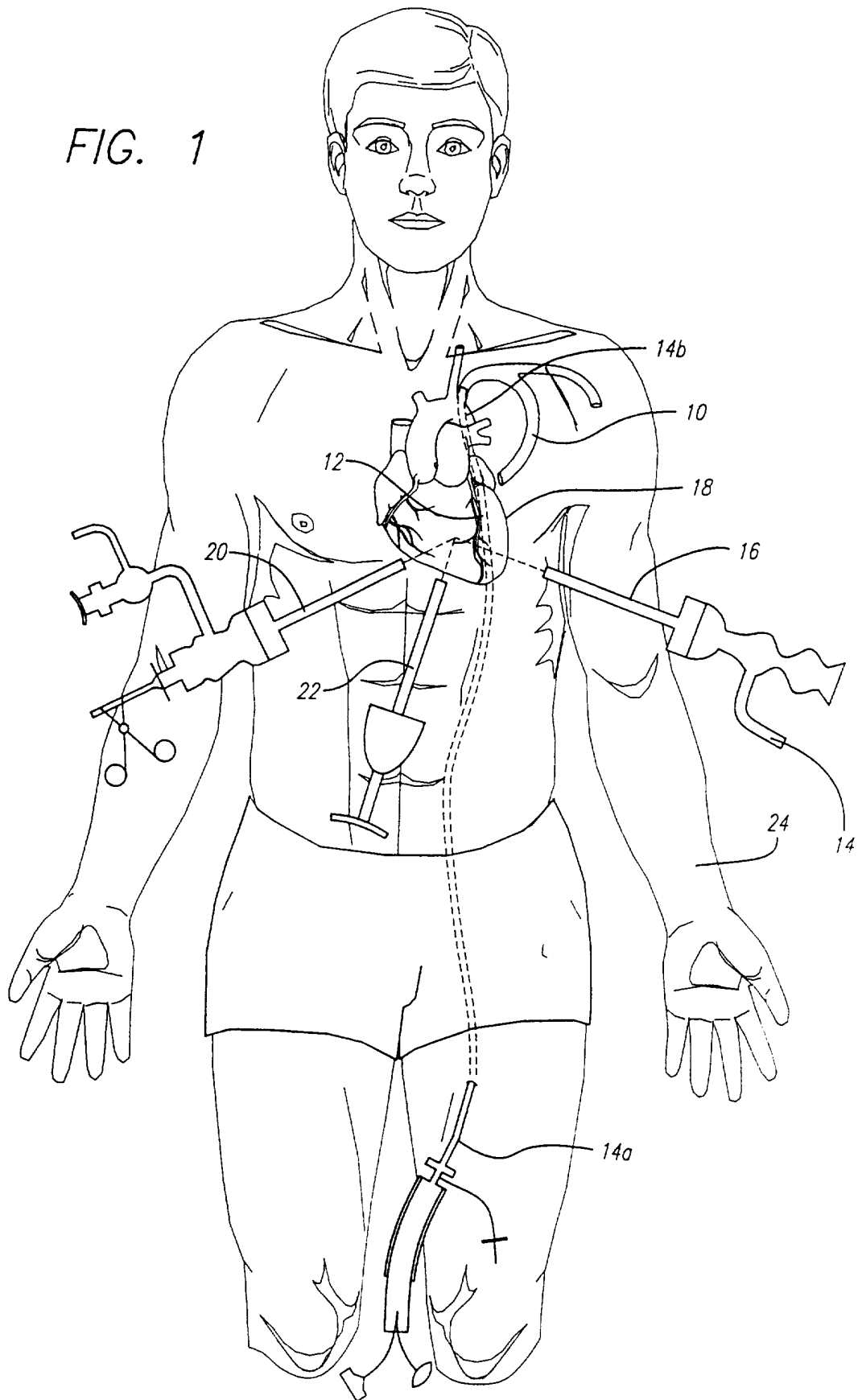

3/11

FIG. 4

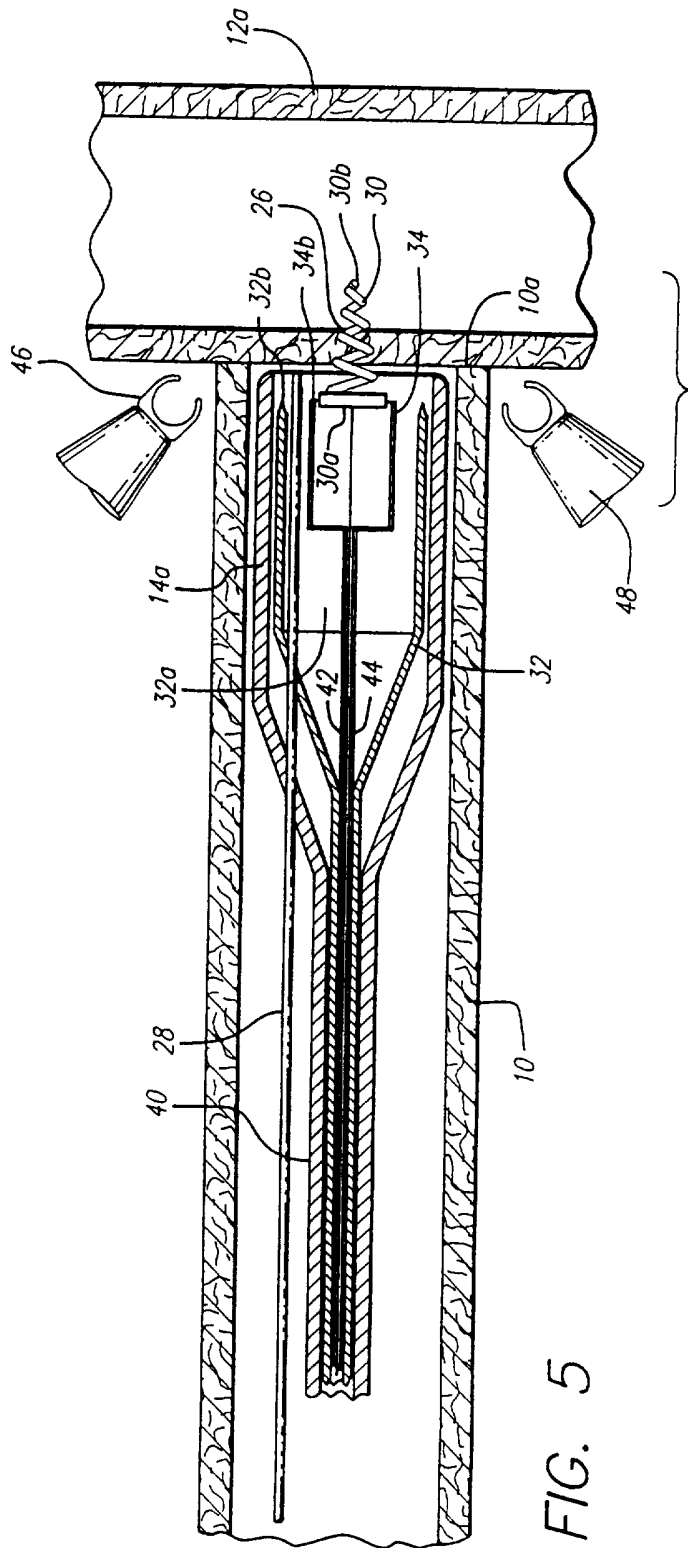
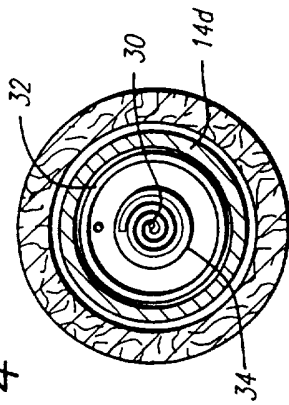

FIG. 5

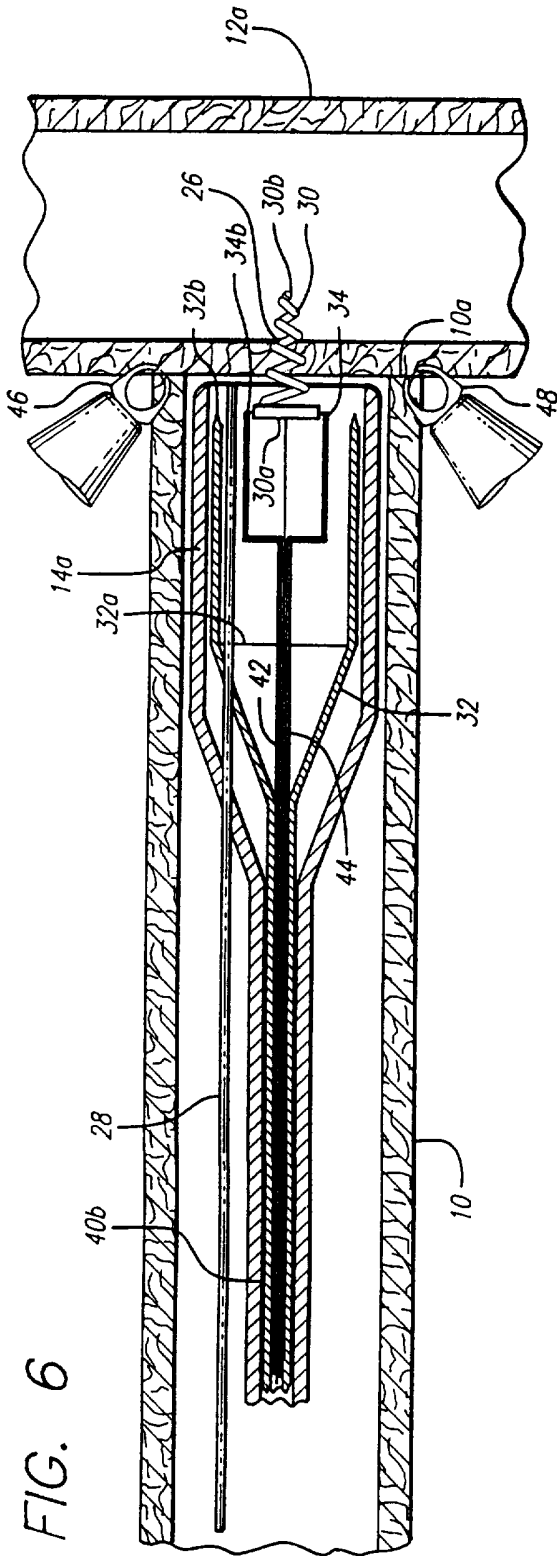

FIG. 6

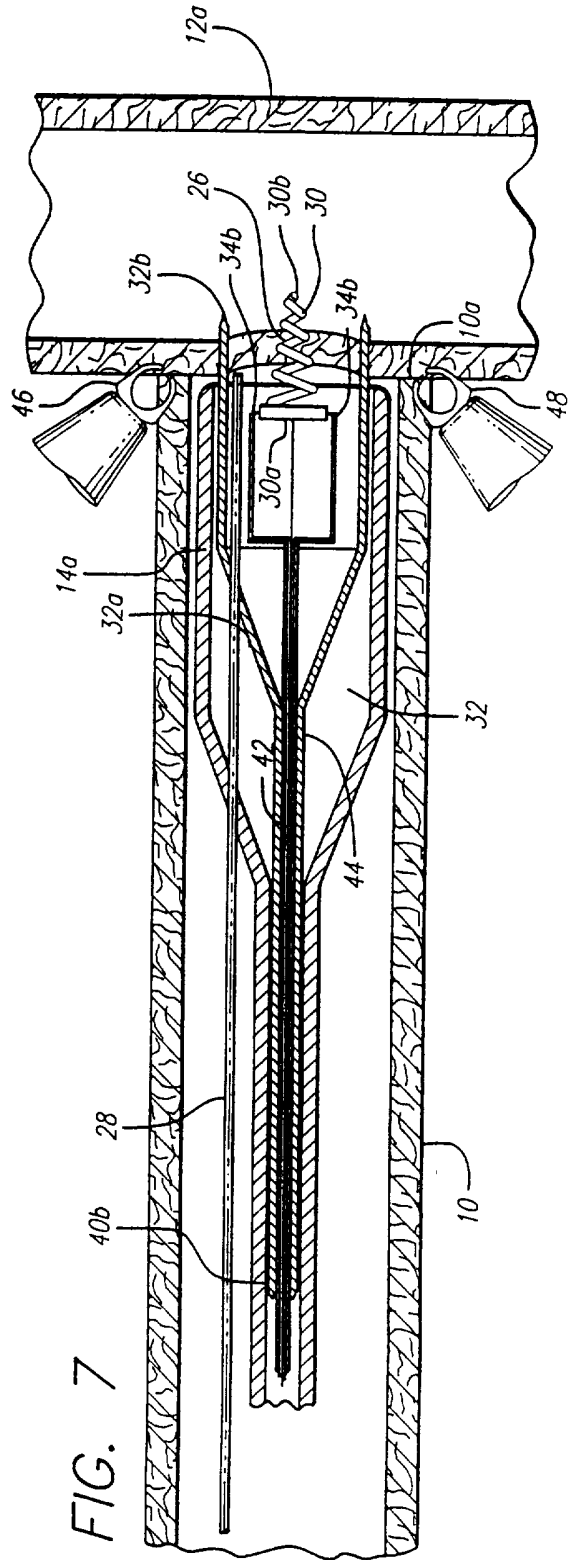

FIG. 7

5/11

FIG. 8

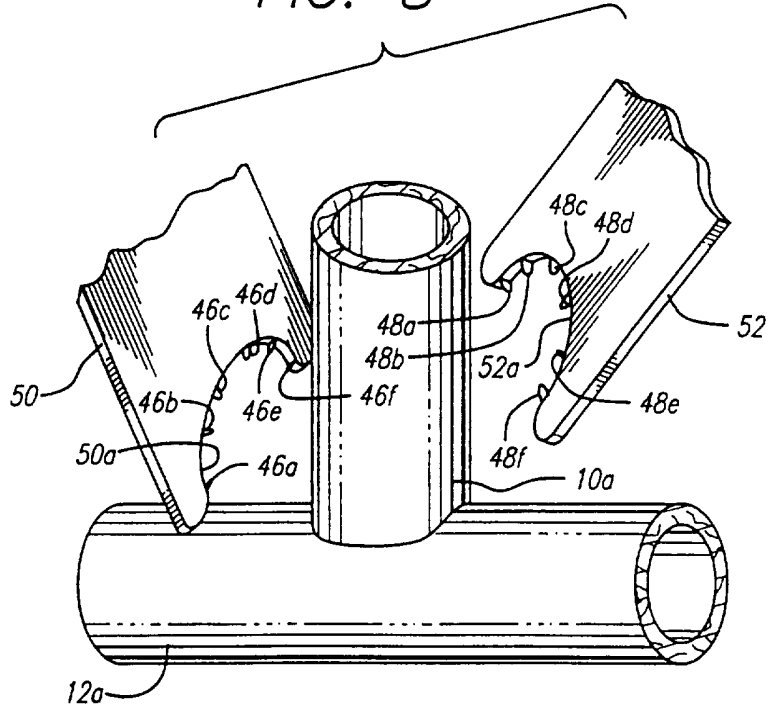

FIG. 9

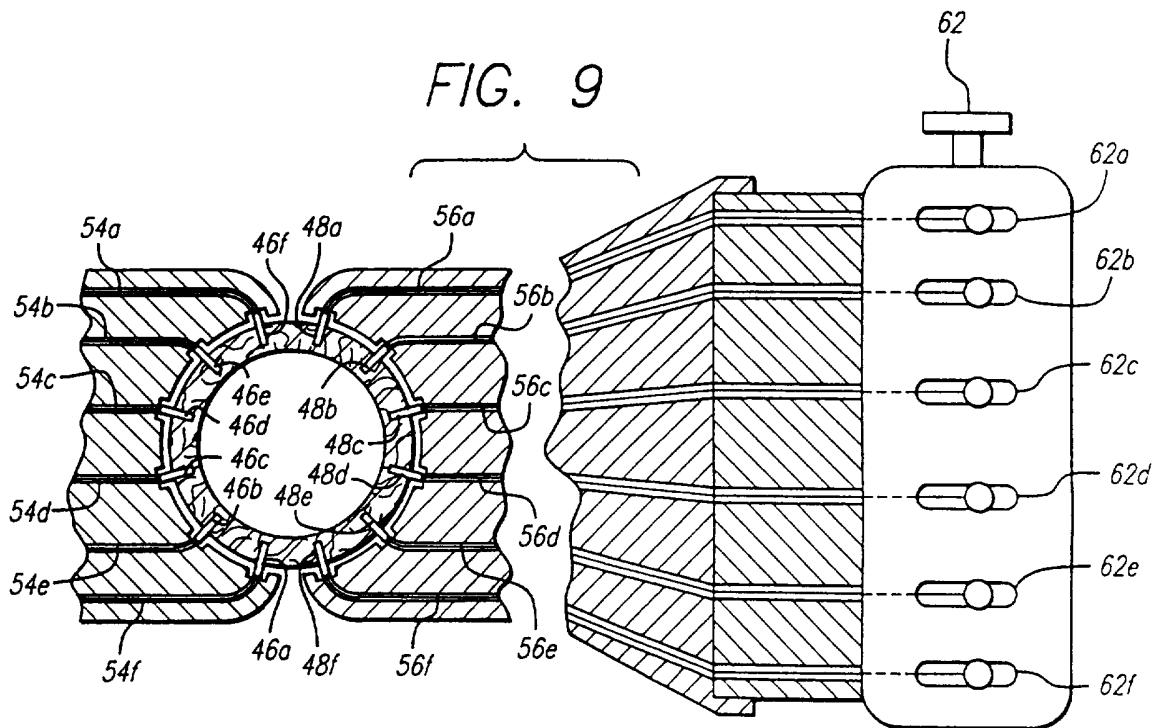

FIG. 10

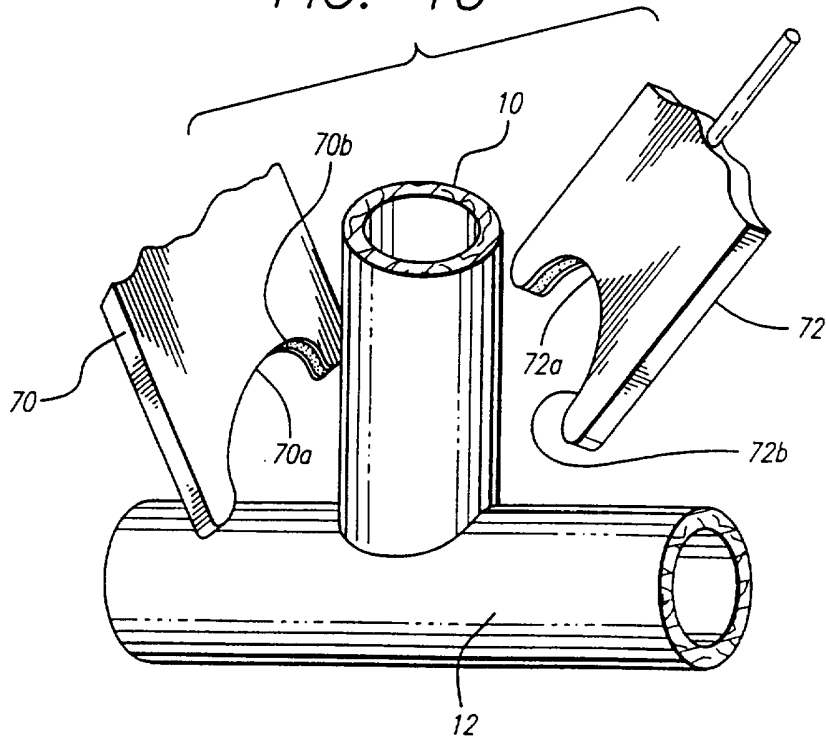

FIG. 11

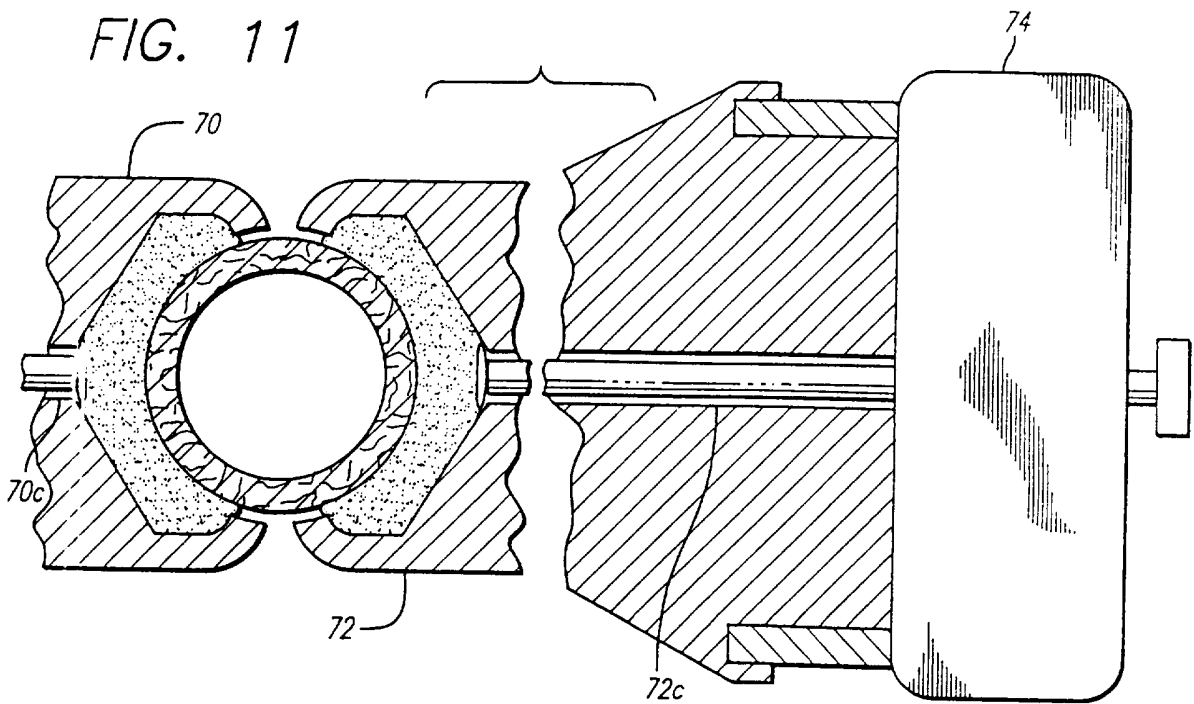
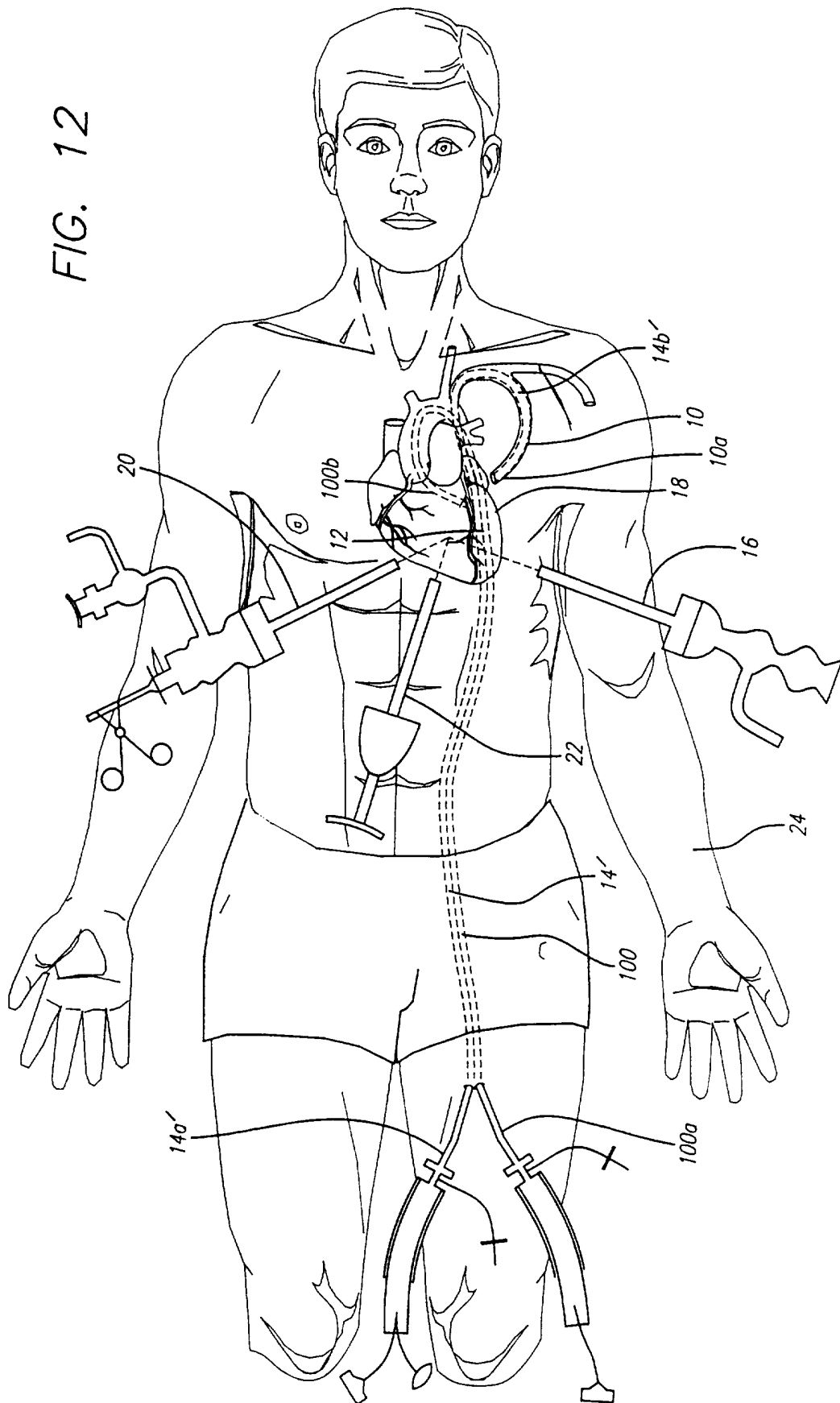

FIG. 12



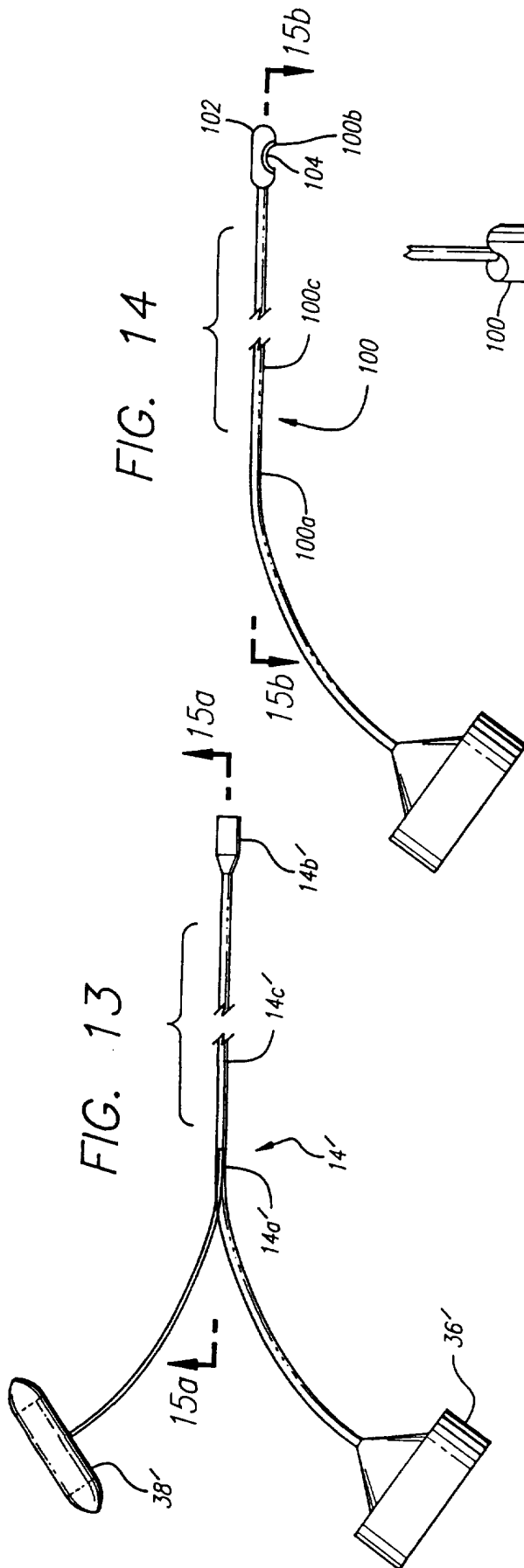

FIG. 14

FIG. 13

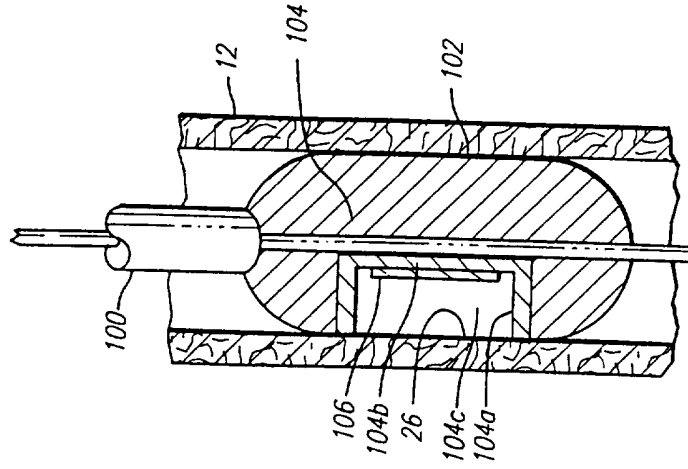

FIG. 15b

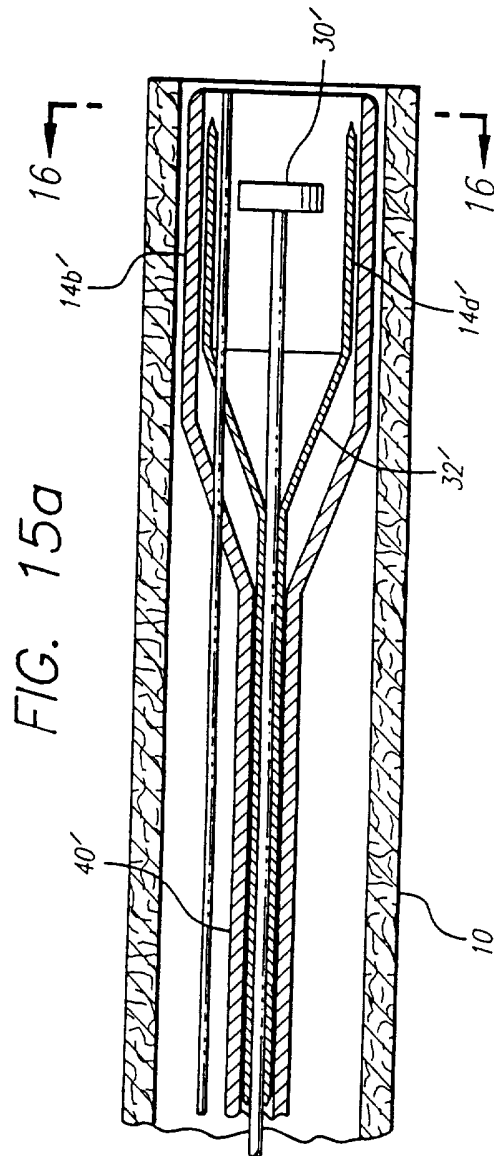

FIG. 15a

FIG. 17

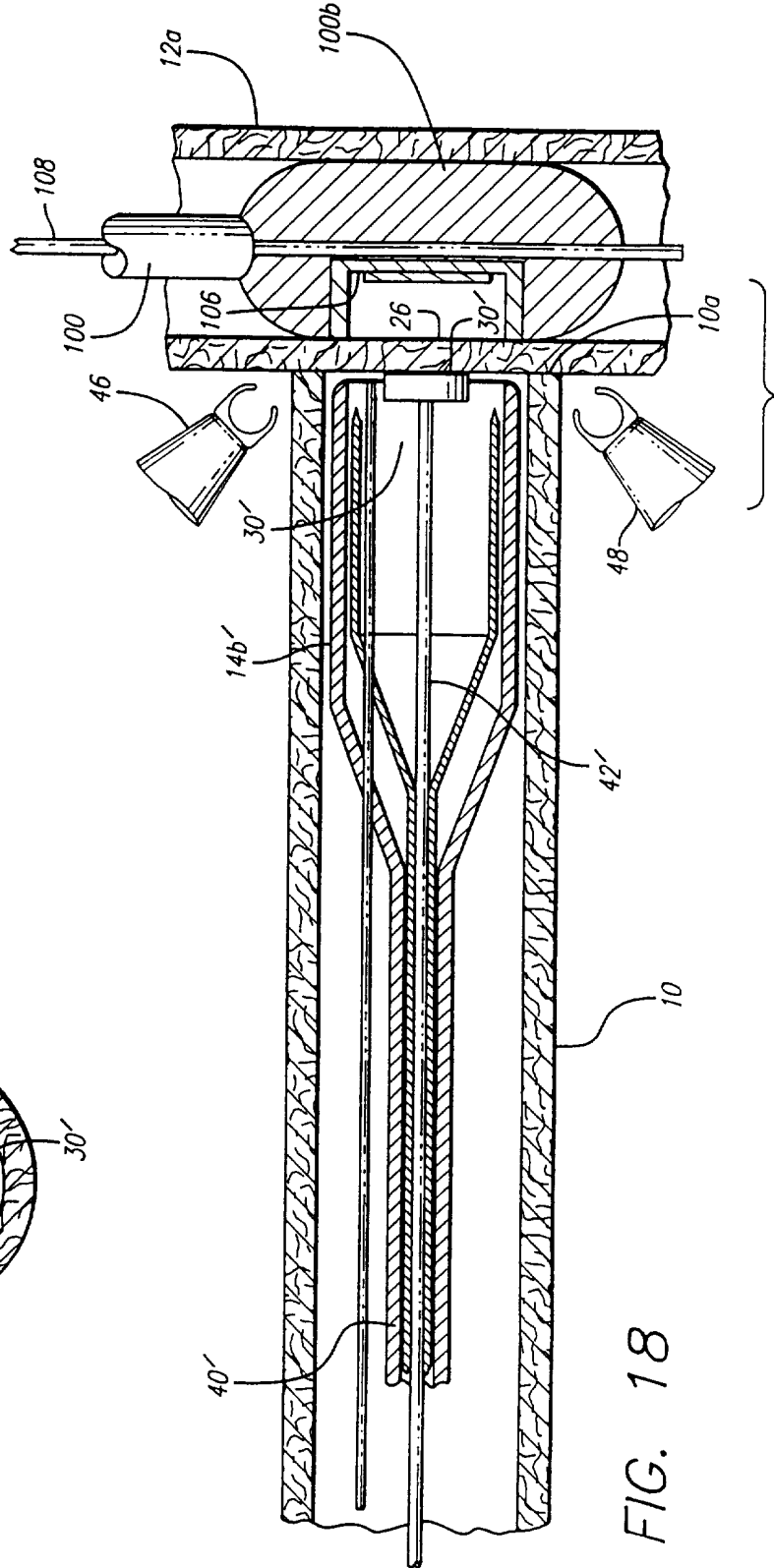
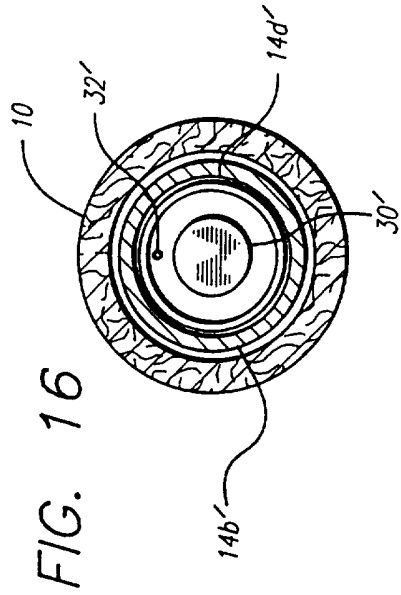
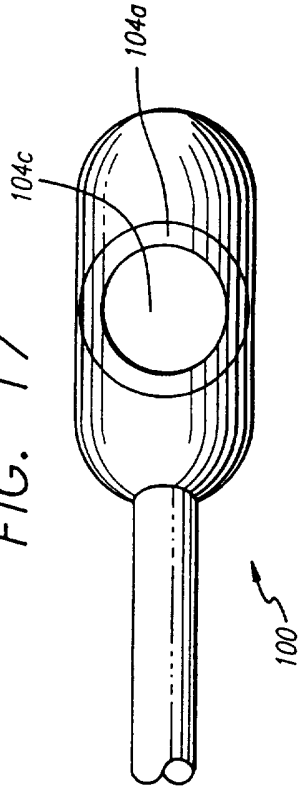

FIG. 18

10/11

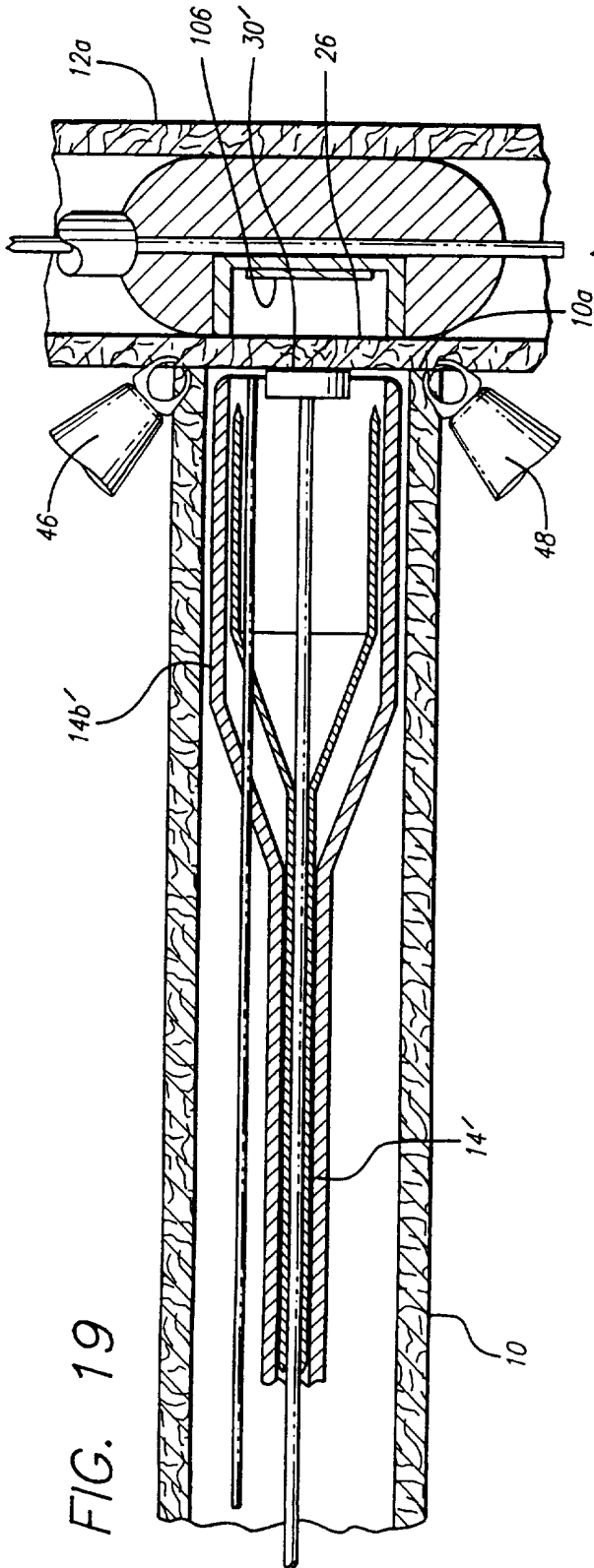

FIG. 19

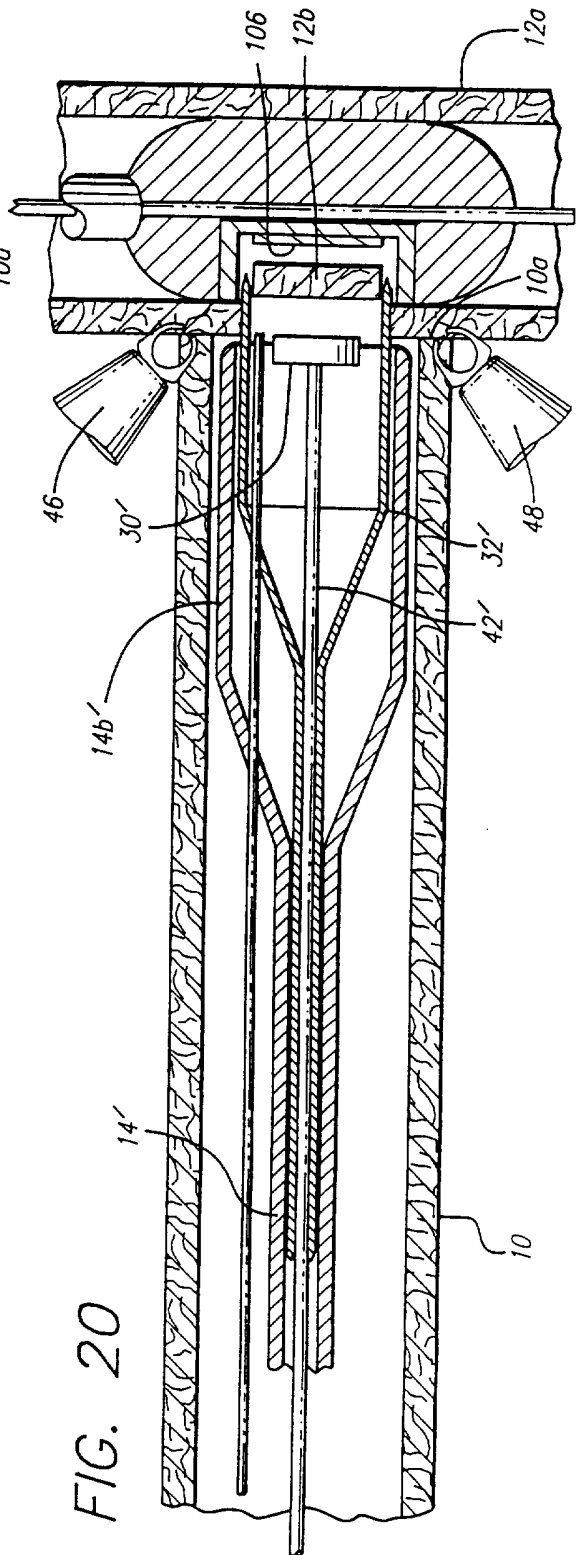

FIG. 20

