



(19) **United States**

(12) **Patent Application Publication**
Riedi

(10) **Pub. No.: US 2002/0134823 A1**

(43) **Pub. Date: Sep. 26, 2002**

(54) **CONTAINER ASSEMBLY**

(57) **ABSTRACT**

(76) Inventor: **Martin Riedi**, Miami, FL (US)

Correspondence Address:
MALLOY & MALLOY, P.A.
2800 S.W. Third Avenue
Historic Coral Way
Miami, FL 33129 (US)

(21) Appl. No.: **09/813,461**

(22) Filed: **Mar. 21, 2001**

Publication Classification

(51) **Int. Cl.⁷ B65D 5/42; B65D 43/08**

(52) **U.S. Cl. 229/122; 229/125.19**

A container assembly which is specifically, but not exclusively, adapted for the storage, shipping and display of relatively fragile products, such as produce, flowers, or the like, wherein the nature of the products renders them particularly vulnerable to damage during the placement within and removal from the interior of the container assembly. Accordingly, the body of the container assembly includes a movably mounted access segment selectively disposable between opened and closed positions, wherein an access opening in the body is established when the access segment is disposed in the opened position. The access opening, when exposed is disposed, dimensioned and configured to facilitate both visual and physical access to the interior of the body as well as a laterally directed positioning of the products as they are placed within and removed from the interior, thereby reducing the possibility of physical damage being done as with vertically directed placement and removal of the products through an open top of a conventional container.

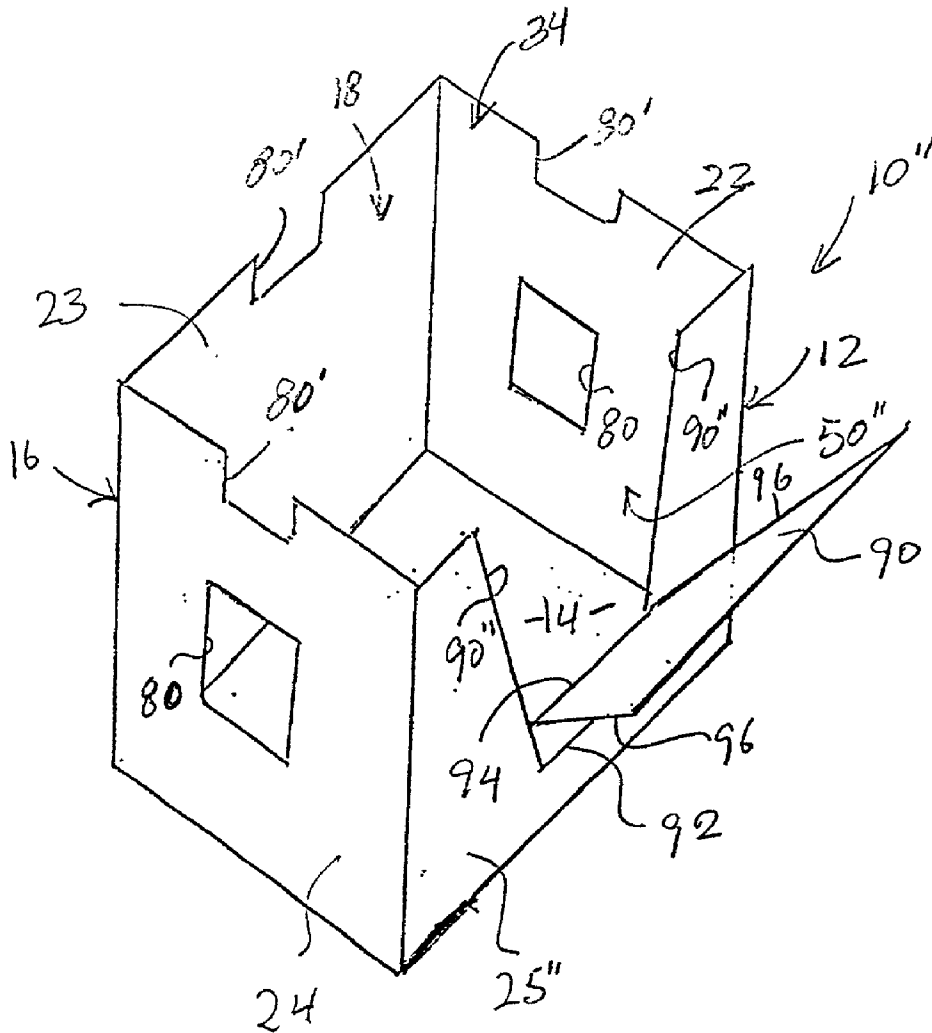

FIG. 1

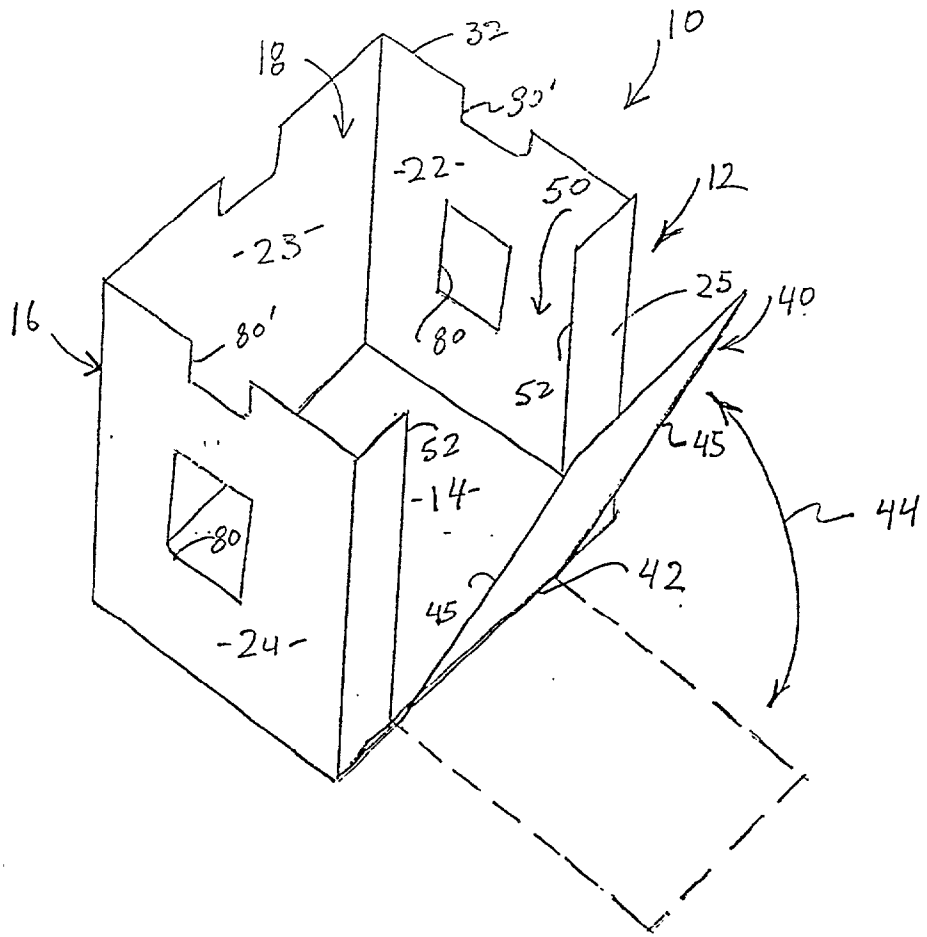

FIG. 2

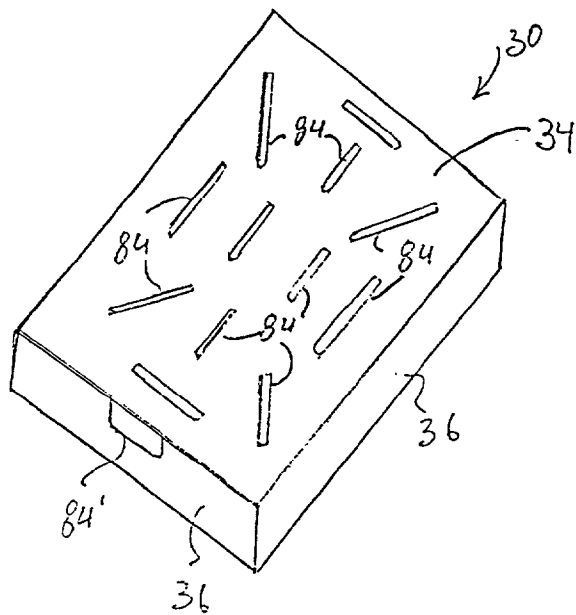

FIG 3

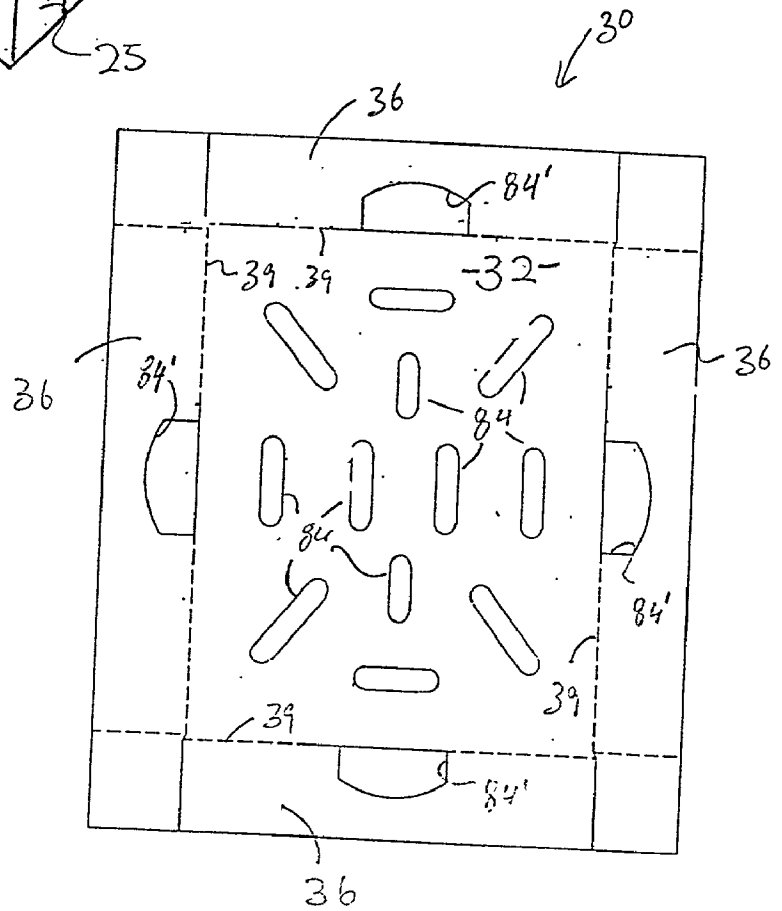
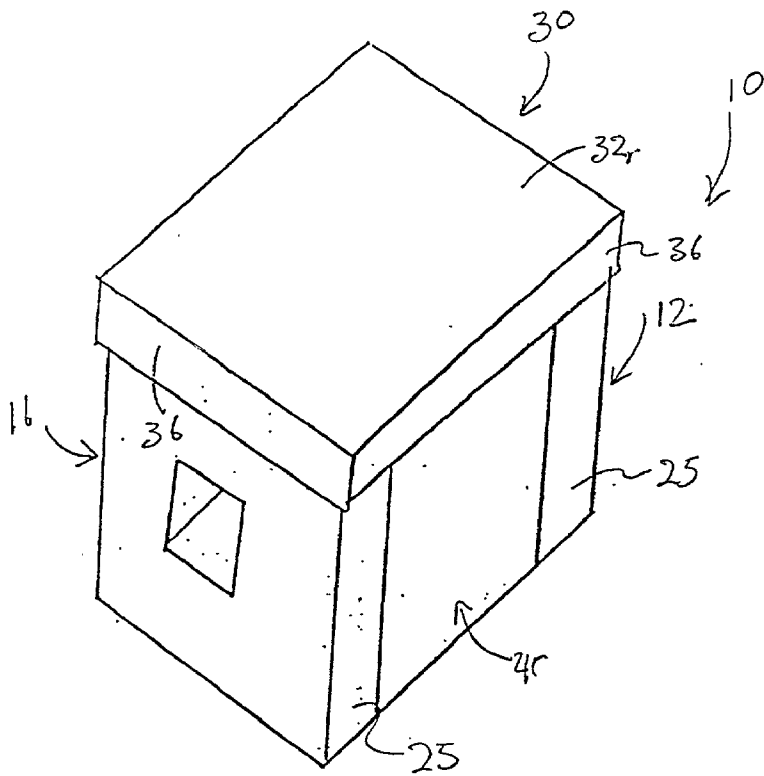

FIG 4

FIG 5

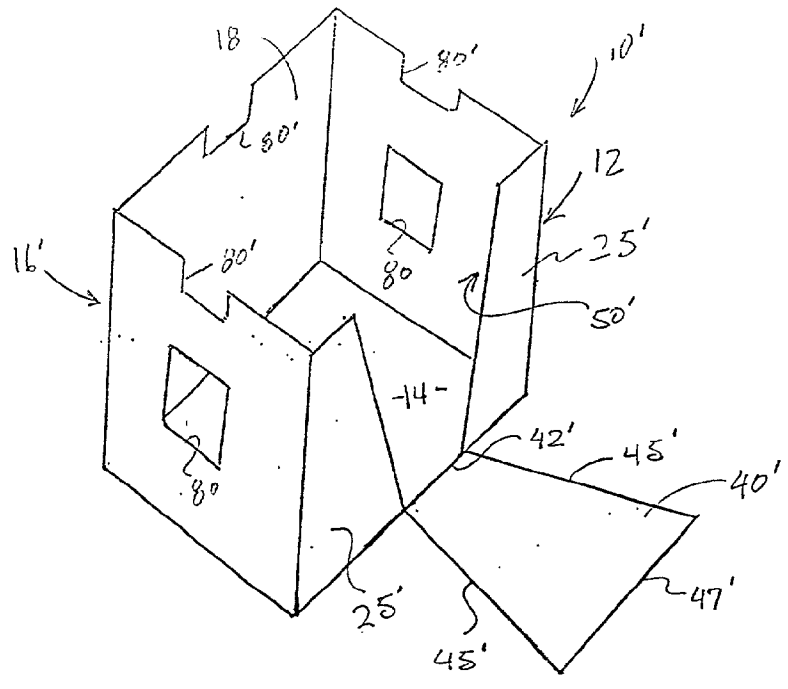
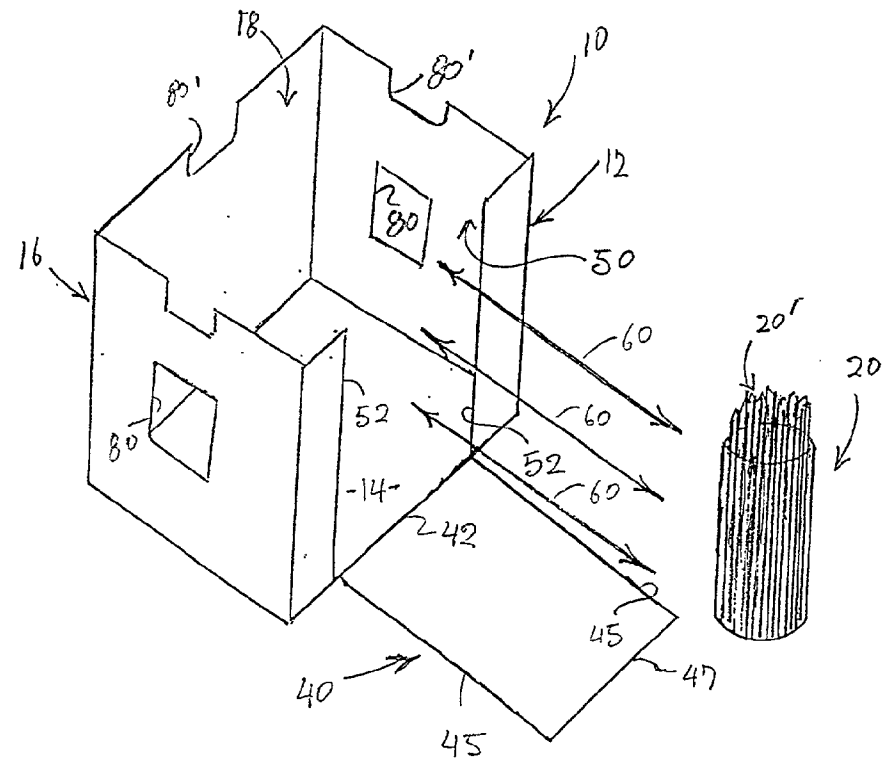

FIG 6



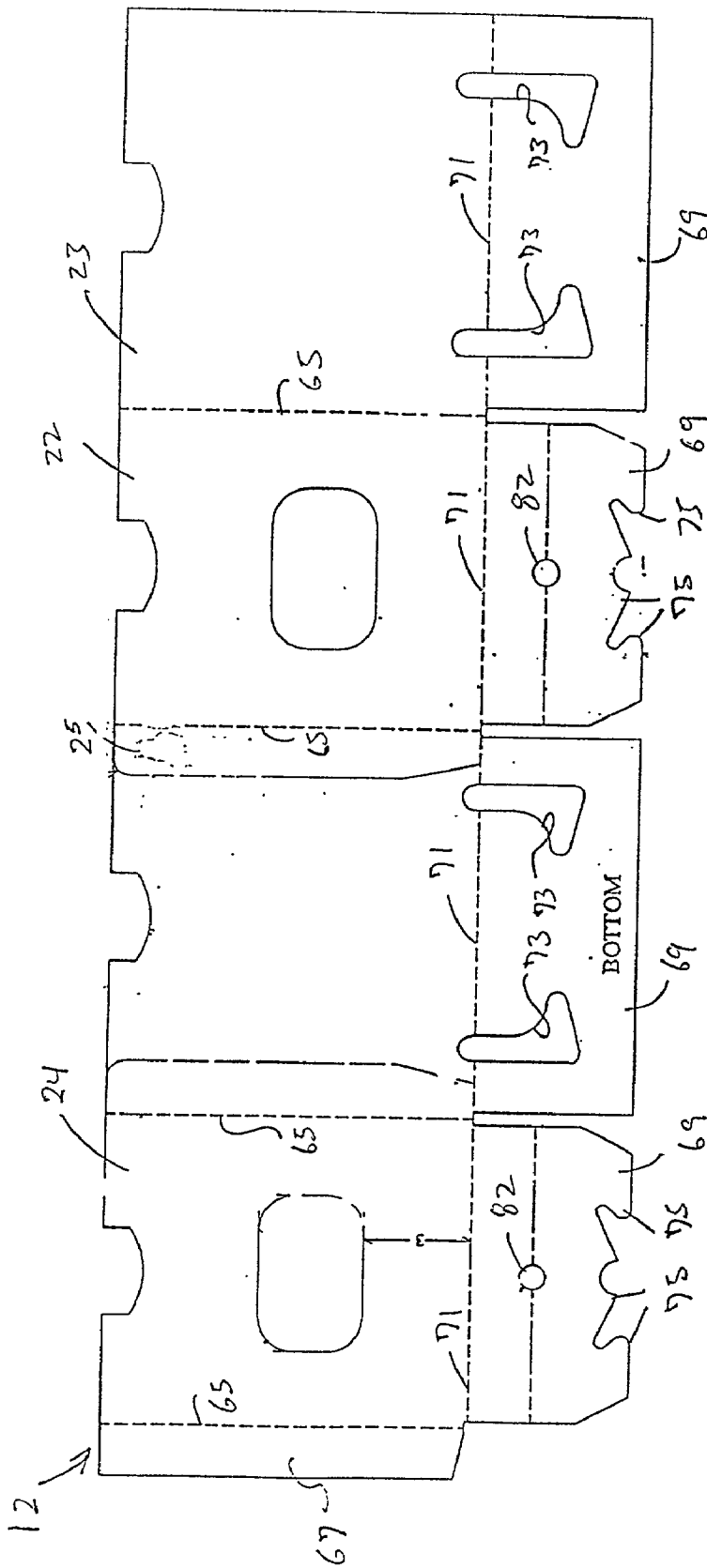

FIG. 7

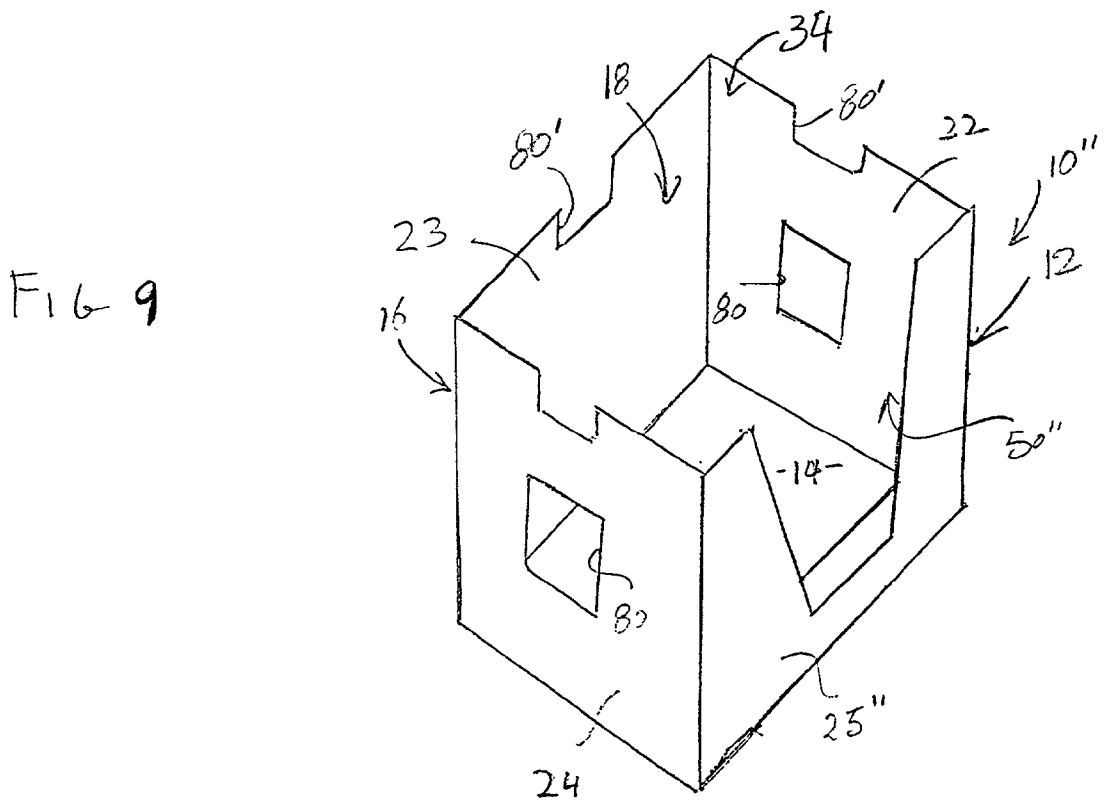
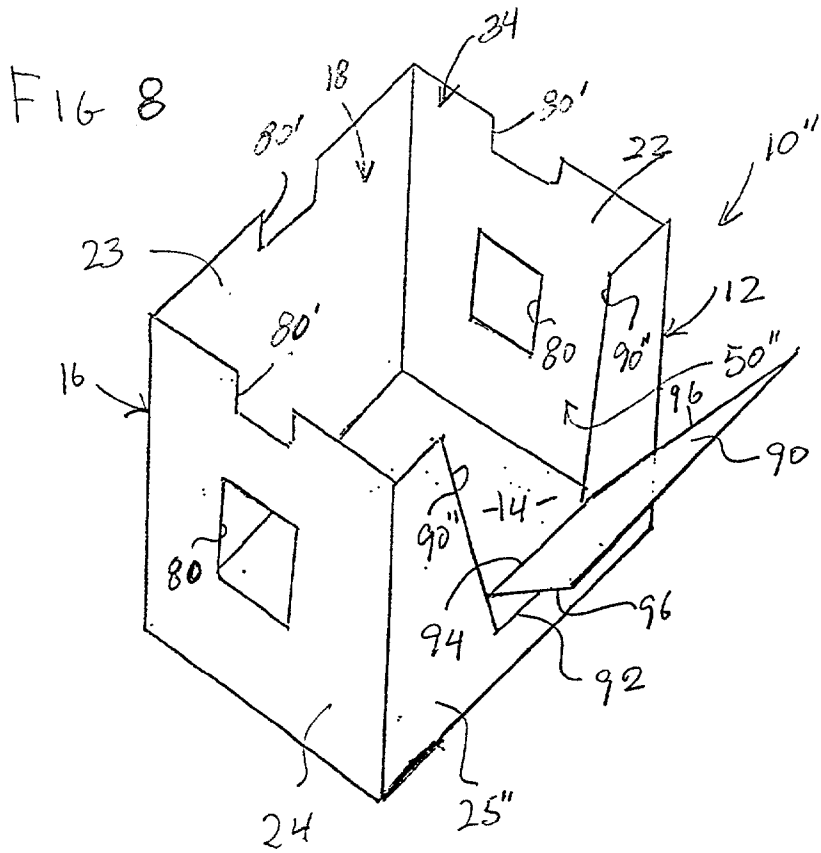

FIG 10

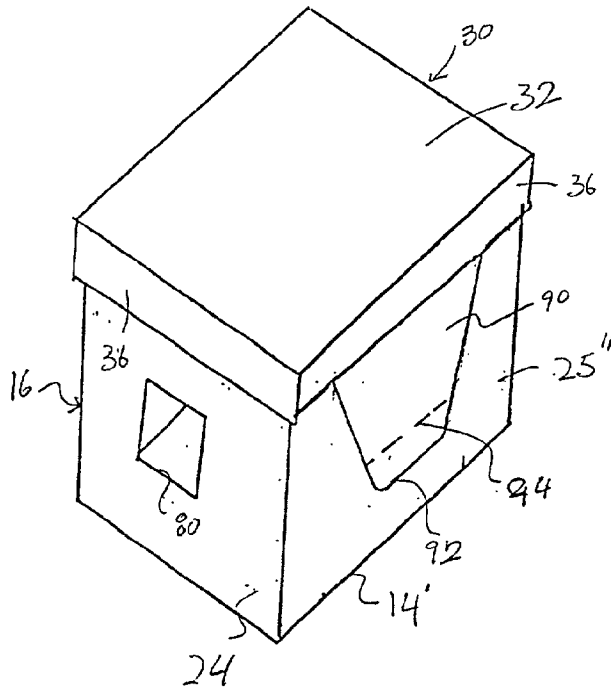

FIG 11

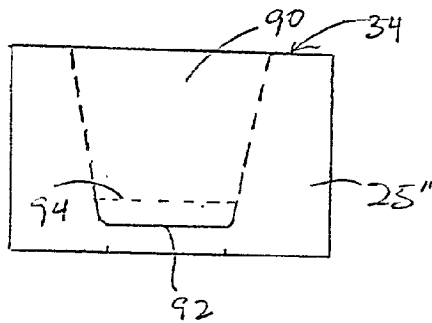

FIG 12

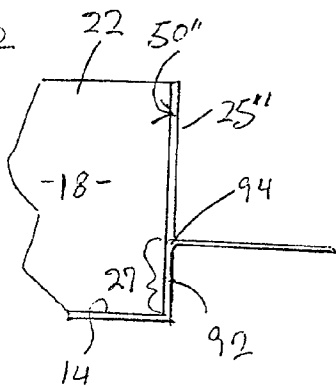
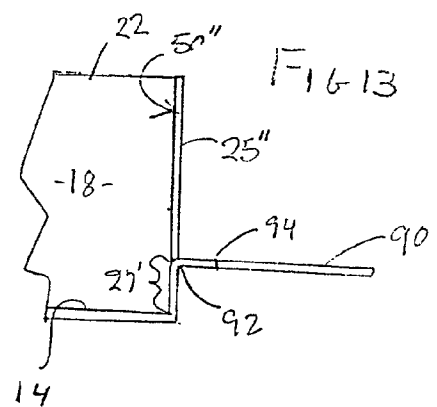

FIG 13



CONTAINER ASSEMBLY

Claim of Priority

[0001] The present application is a continuation-in-part application of previously filed, now pending application Ser. No. (to be determined).

BACKGROUND OF THE INVENTION

[0002] 1. Field of the Invention

[0003] The present invention is directed to a container assembly structured for the containment of relatively fragile products during storage, transportation and display thereof. Moreover, the subject container assembly facilitates product placement into and out of the interior thereof in a manner which eliminates or reduces the possibility of physical damage being done to the products.

[0004] 2. Description of the Related Art

[0005] It is well known that the prior art is replete with containers of various sizes and configurations. Typically containers are used not only for the storage of an immense variety of different products and contents but also are used to protect the products during transport and in some instances, the display of the contained products. The physical characteristics of containers, including the material from which they are formed is, to a large extent, dependent on the products being contained therein. Perhaps the most common material utilized in the construction and formation of known containers is paperboard or cardboard, which in many instances includes a substantially corrugated formation to add strength and stability.

[0006] Also the construction of conventional containers normally involves a single blank or a plurality of interconnected blank sections secured together by fasteners, adhesive or the like and folded along predetermined seam lines so as to define a sidewall and a base. The sidewall and base collectively define the boundaries of a hollow interior in which the contents are placed. Further, the conventional structuring of containers may include the sidewall assembly comprising a plurality of planar, sidewall segments relatively oriented into a multi-sided configuration. The base portion of a typical container structure is folded in overlying, covering relation to a lower open end of the hollow interior and is secured in such covering position by conventional adhesives, fasteners, etc. of the type set forth above.

[0007] A common physical characteristic of the vast majority of known or conventional containers also includes an open top. In order to securely maintain the contents or intended products within the hollow interior, the open top is closed by a removable lid or alternatively by a top portion. The top portion, when not in the form of a removable lid, may comprise a plurality of top panels or segments which are integrally or otherwise secured to the upper peripheral portions of the sidewall assembly. After loading or packing of the intended contents within the hollow interior, such top panels or segments are folded relative to one another and secured by the aforementioned adhesives, fasteners, etc.

[0008] When utilizing the conventional box or container structure, as described above, it is accepted practice to load and un-load the contents into and out of the interior of the container through the open top end after removal of the

closure or top panel segments, as described. The products or contents are substantially vertically directed through the open top and into the hollow interior. Naturally, the precise method and technique of positioning the contents depend on the various characteristics of the contents themselves and more specifically on whether the contents are loosely filled or individually packed. If the product or contents are not particularly fragile, at least in terms of their positioning during packing or unpacking, the vertical passage of these products through the open top end is perfectly acceptable. These commonly applied techniques of packing through the open top end may be most commonly practiced due to the unavailability of alternative and more creative container designs and structures.

[0009] While the loading and unloading through the open top end is acceptable for a large number of the more sturdy products, there exists a more fragile category of products which suffer from the commonly used, vertically directed positioning or passage into and out of the interior of the container. More specifically, many of the more fragile products have a tendency to become physically damaged as they are vertically directed through the open upper top end of a container due to the fact that they physically engage one another or adjacently disposed interior surface portions of the container.

[0010] Also, another common characteristic of the more fragile type of product is that they are typically intended to be maintained in an "up-right" orientation. When such products are positioned or oriented in close proximity to one another, the physical engagement between adjacently disposed products causes the aforementioned damage and because of the vertical direction of their positioning is generally considered to be inevitable. While fragile type products of the type set forth above vary greatly, one specific category of such products comprises vegetables, flowers or other produce, which are typically packed in specific groups or "bunches".

[0011] Based on the above, there is a significant and long recognized need for a container assembly which is structured to eliminate the physical damage commonly suffered by the more fragile type of products, especially during the loading and un-loading procedure. Such an improved or preferred container assembly should also be capable of accomplishing efficient, safe and secured packing of a variety of different products, whether fragile or sturdy, in a manner which is acceptable to mass production techniques and is not overly time consuming. Also, an improved container assembly of the type set forth above, while overcoming the disadvantages and problems associated with vertically directing positioning of products into and out of the container, should be capable of being produced and manufactured at a competitive cost and should be structured, as are conventional containers, to effectively protect the packaged products during storage, shipping, etc. Finally, an improved container assembly should be structured to enhance not only the physical access to the container interior and products contained therein, but the visual access as well.

SUMMARY OF THE INVENTION

[0012] The present invention is directed to a container assembly which is structured to contain, during storage, transportation and display, a variety of different products

which are commonly related by the fact that such products are relatively fragile. However, it is emphasized that the container assembly of the present invention is readily adaptable, with little or no structural modification, for the containment of any number of relatively sturdy or fragile products. Therefore, the structural features incorporated in the subject container assembly, as will be explained in greater detail hereinafter, facilitate the safe, secure and efficient positioning of the products, especially during the loading and un-loading procedures. More specifically, the placement within and removal from the container interior is accomplished in a manner which eliminates or significantly reduces the possibility of physical damage being done to the individual products, due to their engagement or contact with one another or with interior surface portions of the container assembly.

[0013] Accordingly, the container assembly of the present invention comprises a body having a hollow interior portion. The body includes a base disposed in covering relation to one end of the interior. A sidewall assembly is disposed in substantially surrounding relation and, for the most part, defines the lateral boundaries of the hollow interior. The base and the sidewall assembly are integrally or otherwise physically secured to one another so that the base and sidewall assembly can be respectively oriented into the preferred configuration when assembled.

[0014] The body may include an open top or upper end which is normally disposed in spaced, opposed relation to the base of the body. However, in certain embodiments of the container assembly of the present invention, to be described in greater detail hereinafter, the open top or upper end of the body may be limited or eliminated by the provision of a cover or lid type panel disposed in overlying and/or covering relation to the open upper end or top. However, in at least one preferred embodiment of the container assembly of the present invention a cover assembly is provided. The cover assembly is dimensioned and configured to be removably disposed in covering relation to the open top or upper end. As also to be more specifically explained, the cover assembly comprises a panel or like structure disposed in overlying relation to the upper end and a peripheral portion which is connected about the periphery of the panel in depending relation thereto. Moreover, the peripheral portion defines a substantially depending flange having a multi-sided configuration which corresponds to the overall transverse cross-sectional configuration of the sidewall assembly. As such, the depending flange or peripheral portion extends in overlying substantially confronting engagement with the exterior surface of the sidewall assembly adjacent to the open top or upper end of the body.

[0015] Another feature of the present invention is particularly directed to the structuring of the body, including the sidewall assembly and base, in such a manner as to facilitate positioning of contents within and removal from the hollow interior thereof during packing and un-packing. Moreover, product positioning may be easily and efficiently performed in a manner which eliminates or significantly reduces the possibility of physical damage being done to the products or contents.

[0016] In conventional box or container design it is generally accepted practice to load and remove the contents into and out of the interior through the open top end thereof.

While such loading and un-loading procedures are acceptable for a large number of products, a more fragile category of products have a tendency to become physically damaged as they are vertically directed through the open upper top or end of a container by physical contact or engagement with one another or with various interior surface portions of the container. A common characteristic of these fragile-type products is that they are typically maintained in a "up-right" orientation and positioned or "packed" in such close proximity to one another that physical engagement between adjacently disposed products, during such vertically directed positioning is inevitable.

[0017] Accordingly, the container assembly of the present invention, comprises an access segment movably connected to or mounted on the body and selectively positionable between an opened position and a closed position. In the opened position both visual and physical access to the hollow interior of the body, and the contents contained therein, are facilitated. Further, when the access segment is disposed at least partially or completely in the opened position, an access opening is created in the body. The creation or establishment of the access opening occurs upon displacement of the access segment, outwardly from the sidewall of the body or other portion thereof in which it is formed and with which it is aligned when in its closed position. Therefore, the periphery of the access opening substantially corresponds, along at least a significant portion thereof, to the peripheral edge of the access segment thereby facilitating re-alignment between the access segment and the access opening when the access segment is again disposed back into its closed position in co-planar relation with the sidewall or other portion of the body from which the access segment is formed.

[0018] When established, the access opening is disposed, configured and dimensioned to facilitate laterally directed placement of individual products, or groupings of products, into and out of the hollow interior of the body. The referred to laterally directed placement is clearly distinguishable from the vertically directed placement, such as when the products or contents are placed within or removed from the hollow interior through a conventionally disposed opened top end of the body of the container. Further, the laterally directed placement of the contents is accomplished while the contents or products are disposed in a preferred up-right orientation.

[0019] More specifically, the products are capable of being placed within and removed from the hollow interior of the body in the same up-right orientation in which they are maintained while they are being stored or transported within the body. Movable engagement such as physical sliding, rubbing or abutting contact is eliminated or reduced, especially during the loading and unloading procedure. When loaded or when it is desired to maintain the contents or products on the interior of the body in segregated relation from the exterior thereof, such as during storage or transport, the access segment is positioned into the aforementioned closed position. The cover assembly is then placed over the open top or upper end of the body in retaining relation to the upper end of the access segment.

[0020] As set forth above, a preferred embodiment of the cover assembly includes a depending flange. As such, the depending flange may serve as a retaining structure such that

it overlaps and is thereby disposed in confronting engagement with the exterior surface of the upper end of the sidewall assembly. In such a position the upper end of the access segment is also engaged and retained, when the access opening is disposed in the closed position.

[0021] Yet another embodiment of the container assembly of the present invention is structured to include all the physical and operative characteristics and attributes as set forth above, but additionally facilitates the display of the products contained within the interior of the body. Also in this preferred embodiment of the present invention, the products are easily displayed by enhancing both the visual and physical access to the products, through the access opening formed in the sidewall, or other portion of the body. At the same time it is assured that the products are safely retained within the interior, even when the access segment is disposed in the open position for display.

[0022] To further enhance the aforementioned visual and physical access to the products within the interior of the body, and to maintain the laterally directed positioning of the products into and out of the body, the opened position of the access segment may assume a variety of different orientations. More specifically, the access segment or a significant portion thereof may be entirely removed from the body, thereby permanently establishing the access opening. Alternatively, the open position may be defined by the access segment folded outwardly from the sidewall of the body along a plurality of connecting seams, creases, fold lines or the like. However, each of the aforementioned seams or fold lines, about which the access segment may be pivoted, is disposed in spaced relation to the bottom or base of the body. By virtue of this positioning of the fold lines, a significant portion of the sidewall remains and extends upwardly from the base so as to further aid in maintaining the objects on the interior of the body during the visual inspection or display. However, the presence of this additional sidewall section does not inhibit the laterally directed positioning of the products into and out of the body interior.

[0023] Therefore, the container assembly of the present invention, including the various embodiments thereof, overcomes significant and long recognized problems existing in the storage, shipping and display of fragile products such as, but not limited to produce, flowers, and the like. In addition, physical damage to the products, especially during the loading and unloading procedures, is eliminated or significantly reduced by laterally directing, as versus vertically directing, the positioning of the products into and out of the hollow interior of the container.

[0024] It is emphasized that the terms "vertically directed" and "laterally directed" as used herein are meant to describe the direction of movement of the products, as they are disposed into and out of the container interior, in a manner more specifically disclosed in the accompanying drawings. These terms are not intended and should not be construed in a limiting sense, such as when either the container assembly or the products are disposed in an orientation other than that shown in the accompanying drawings.

[0025] These and other objects, features and advantages of the present invention will become more clear when the drawings as well as the detailed description are taken into consideration.

BRIEF DESCRIPTION OF THE DRAWINGS

[0026] For a fuller understanding of the nature of the present invention, reference should be had to the following detailed description taken in connection with the accompanying drawings in which:

[0027] **FIG. 1** is a perspective view in partial phantom of both interior and exterior portions of one embodiment of the container assembly of the present invention.

[0028] **FIG. 2** is a top perspective view of a cover assembly associated with the container assembly of the present invention.

[0029] **FIG. 3** is an exterior perspective view of the embodiment of the container assembly of **FIGS. 1 and 2** in a closed orientation.

[0030] **FIG. 4** is front plan view of a blank from which the cover assembly of the embodiment of **FIG. 2** is formed.

[0031] **FIG. 5** is a perspective view showing both interior and exterior portions of another preferred embodiment of the container assembly of the present invention.

[0032] **FIG. 6** is a perspective view of one preferred embodiment of the present invention wherein laterally directed placement and removal of a product, relative to the interior of the container assembly of the present invention, is schematically demonstrated.

[0033] **FIG. 7** is a front plan view of a blank from which the body of at least one of the preferred embodiments of the container assembly is formed.

[0034] **FIG. 8** is a top perspective view of yet another preferred embodiment of the container assembly of the present invention.

[0035] **FIG. 9** is a top perspective view of the embodiment of **FIG. 8** with at least a portion of the access segment removed.

[0036] **FIG. 10** is an exterior perspective view of the embodiment of **FIGS. 8 and 9** including a closure for maintaining the container assembly of the present invention in a closed orientation.

[0037] **FIG. 11** is a front plan view of a sidewall section of the body of the embodiment of **FIGS. 8 through 10**, with the access segment disposed in a closed position.

[0038] **FIG. 12** is a sectional view in partial cutaway of the embodiments of **FIGS. 8 through 11** with the access segment oriented in one of a plurality of open positions.

[0039] **FIG. 13** is a sectional view in partial cutaway of the embodiments of **FIGS. 1 through 11** with the access segment located in a different one of a plurality of open positions from that of **FIG. 12**.

[0040] Like reference numerals refer to like parts throughout the several views of the drawings.

DETAILED DESCRIPTION OF THE PREFERRED EMBODIMENT

[0041] As shown in the accompanying Figures, the container assembly of the present invention is generally indicated as **10** and includes a body **12** comprising a base **14** and a sidewall assembly generally indicated as **16**. The base **14**

and the sidewall assembly **16** collectively and at least partially defining the boundaries of a hollow interior portion generally indicated as **18**. In conventional fashion, the hollow interior **18** is provided for the containment of a variety of different products and, as will be explained in greater detail hereinafter, is particularly adaptable for containment of a variety of different, relatively fragile products generally indicated as **20** in **FIG. 6**.

[0042] As disclosed in the various Figures, the sidewall assembly comprises a plurality of sidewall segments **22**, **23**, **24**, and **25** which collectively comprise a multi-sided configuration. It is emphasized that the configuration of the sidewall assembly and accordingly the entire body **12** can of course vary and still be included within the spirit and scope of the present invention. The configurations of the body **12** may include a multi-sided configuration, having a plurality of side segments varying in number and being more or less than the four side segments **22** through **25** indicated in the various Figures. Alternatively, the sidewall assembly **12** can be structured to have a partially or completely continuous, substantially cylindrical configuration which would vary the overall configuration of the body **12** accordingly. Naturally, the base **14** is correspondingly dimensioned and configured to correspond to any of the possible plurality of multi-sided or cylindrical configurations which the side assembly **16** may assume. The bottom end of the body **12** would therefore be completely or at least partially closed such that the contents disposed within the hollow interior **18** are capable of being adequately supported in a preferred orientation.

[0043] As best shown in **FIGS. 2 through 4**, the container assembly **10** of the present invention further comprises a cover assembly generally indicated as **30**. The cover assembly **30** is removably disposed in overlying, covering relation to the open top end **34** so as to removably close the top end **34** during storage or shipment of the contents of the container assembly **10** or as otherwise desired. The cover assembly **30** includes a base panel **32** and at least one, but preferably a plurality of depending peripheral flanges or like structures **36** extending outwardly from the base panel **32**. When the cover assembly **30** is disposed in covering relation to the open end **32**, as disclosed in **FIG. 3**, the depending flanges **36** are positioned to overly and confrontingly engage the upper exterior portions of the sidewall assembly **16**. More particularly, each of the upper exterior surfaces of the sidewall segments **22**, **23**, **24**, and **25** are substantially covered. As such, the depending flange or flange segments **36** comprise a retaining structure, as will be explained in greater detail hereinafter.

[0044] With primary reference to **FIG. 4**, the cover assembly **30**, including the cover panel **32** and the depending flange or flange segments **36**, are preferably formed from a single blank of material of the type applicable in the construction of the container assembly **10**. The formation of the cover assembly **30** into its operative configuration, as shown in **FIG. 2**, is accomplished by folding the various individual depending flange segments **36** about predetermined fold lines **39** integrally formed in the blank of **FIG. 4**. When folded into the desired configuration overlapping portions of the flange segments **36**, such as at the perspective corners thereof, are secured to one another such as by adhesive commonly used in the container manufacturing industry. It is emphasized that with all of the preferred embodiments of the container assembly **10** of the present invention it is

preferred that the blank from which the body and the cover assembly are formed are of an integral or one piece construction. As such the respective blanks may be folded into the desired, operative configuration by interlocking flaps or segments as will be explained in greater detail with regard to **FIGS. 4, 7** and **14**. The blanks from which the various structures are formed are therefore structured to eliminate where possible the use of staples or other potentially hazardous connectors or fasteners. It is well recognized in the container industry that such staples or sharpened connectors frequently cause injury during the loading and unloading procedures and particularly during repeated physical access to the interior as when the container products are displayed and frequently removed for physical examination, purchase, etc.

[0045] Another structural feature of the present invention comprises the provision of an access segment generally indicated as **40** in the embodiment of **FIGS. 1, 6**, and **7**. The access segment **40** preferably comprises a panel having a planar or other configuration which corresponds to the configuration of the individual sidewall segments, particularly the sidewall segment **25** with which it is more closely associated. By way of example, if the sidewall assembly **12** was defined by one or more cylindrical sidewall segments, the access segment **40** could also have a corresponding and substantially mating configuration for the reasons which may be best understood hereinafter.

[0046] Moreover, the access segment **40** is movably connected to the body **12** and in the embodiment of **FIGS. 1, 3** and **6** the access segment **40** is pivotally or otherwise movably connected to a periphery of the base **14** such as along seam or fold line **42** which defines a movable connection. By virtue of this movable connection, the access segment **40** can be selectively disposed between an opened position, as clearly shown in **FIG. 6** and partially represented in **FIG. 1**, and a closed position as shown in **FIG. 3**. Positioning of the access segment **40** between the opened and closed positions is schematically represented in **FIG. 1** by directional arrow **44**. Further, the fully opened position of the access segment **40** is represented by it being disposed in substantially coplanar relation to the base **14**. However, the movable connection **42** is constructed to allow the access segment **40** to be oriented at various angles relative to the base **14**. The access segment **40** may even be oriented so as to extend beyond or beneath the base **14**. Therefore, the position of the access segment **40** may at least partially depend on the location and configuration of the support surface on which the body **12** is disposed, when the access segment **40** is in its opened position. It should also be noted that the movable connection **42** of the access segment **40** to the body **12** and in particular to the sidewall segment **25**, may be located other than contiguous to the base **14** as disclosed on the preferred embodiment of **FIGS. 8 through 13**. Also, and by way of example only, a longitudinal peripheral edge **45** could define a hinged connection which allows selective movement of the access segment **40** between its opened and closed positions.

[0047] Another embodiment of the present invention is shown in **FIG. 5** wherein access segment **40'** is also selectively positionable between an opened position, as shown, or a closed position defined by the access segment **40'** being disposed in substantially coplanar relation to the sidewall assembly **16'** and in particular the corresponding sidewall

segment 25'. As with the embodiment of FIG. 1, the access segment 40' is movably connected to the body such as along a movable connection 42'. As such, the lower end of the access segment 40' is pivotally connected to the base 14 such that it may be selectively oriented between the aforementioned opened and closed positions.

[0048] The enhancement of both physical and visual access to the hollow interior 18 is accomplished by the creation or establishment of an access opening 50 or 50' in the respective embodiments of FIGS. 1 and 5. The establishment of the access opening 50 or 50' is of course accomplished by positioning the respective access segments 40 and 40' into the opened position.

[0049] The existence of the access opening 50 or 50' allows direct communication with the hollow interior 18 from the exterior of the body 12, as should be evident. Positioning of the products 20 in a lateral direction into and out of the hollow interior 18 is thereby made possible as well as the displaying the contents within the interior 18.

[0050] The structural features which distinguish the embodiments of FIG. 1 and 5 comprise the relative position and orientations of the longitudinal, peripheral edges or portions 45, 45' of FIG. 1 and 45'45', of FIG. 5. More specifically, in the preferred embodiment of the container assembly 10 of FIGS. 1, 3, and 6, the longitudinal peripheral portions or it edges 45 are disposed in substantially equally spaced apart and accordingly parallel relation to another. Similarly, the access opening 50, being correspondingly configured to that of the access segment 40, has its longitudinal peripheral portions or edges 52 also disposed in substantially parallel relation to one another along their length. Alternatively, in the embodiment of FIG. 6, the access segment 40' has its configuration defined at least in part by a relatively angled orientation of the longitudinal peripheral portions or edges 45'. Therefore, peripheral portions 45' substantially converge as they extend from an upper or outer most end 47' towards the movable connection 42'.

[0051] The variations in the structures between the embodiments of FIGS. 1 and 5 may be attributable to the dimension, configuration or even the type of product being loaded into the hollow interior portion 18. In addition, varying amounts of stability may be attributed to the different structures and configurations of the respective access segments 40 and 40' as well as the formed access opening 50 and 50', as described above.

[0052] Yet another preferred embodiment of the present invention is shown in FIGS. 8 through 13 and comprises the container assembly generally indicated as 10" having a body 12 which is similarly, while not identically structured, relative to the embodiments of FIGS. 1 through 7. More specifically, the body 12 includes a sidewall assembly comprising a plurality of sidewalls 22, 23, 24 and 25" as well as a hollow interior 18 and a base 14. The sidewall assembly 16 and the base 14 at least partially define the boundaries of the hollow interior 18 which is further characterized by having an opened upper or top end 34. As with the previous embodiments, a cover assembly 34 including a base panel 32 and one or more depending retaining flanges or segments 36 is selectively positionable in covering relation to the open end 34 and in an operative, retaining position, as will be described in greater detailed hereinafter.

[0053] More specifically, the preferred embodiment of FIGS. 8 through 13 comprises an access segment 90 selectively disposable between a plurality of opened positions and a closed position. The closed position is shown in FIGS. 10 and 11, wherein the access segment 90 is disposed in co-planar relation to the sidewall assembly 16 and more particularly the sidewall segment 25". In addition, the access segment 90 is disposable into anyone of a plurality of opened positions due to the provision of a plurality of movable connections 92 and 94. Each of the movable connections 92 and 94 are disposed in spaced relation to one another and each are disposed in spaced relation to the base 14. Further, as shown in FIGS. 8 through 10, the movable connections 92 and 94 are disposed in somewhat parallel orientation relative to the junction 14' between the base 14 and the sidewall as segment 25".

[0054] By virtue of the provision of the plurality of movable connections 92 and 94 the access segment 90 is selectively movable outwardly from its normally co-planar relation to the sidewall segment 25", when in its closed position. Accordingly, either of the movable connections 92 and 94 may comprise an elongated seam, crease or fold line about which the remainder or upper portion of the access segment 50 may pivot or be folded as best shown in FIGS. 12 and 13. Accordingly, when the access segment 90 is folded about the movable connection 94 the resulting access opening 50" has a predetermined size and configuration which allows for the lateral positioning of an object or product 20 into and out of the hollow interior 18, as set forth above. However, the lower portion of the sidewall segment 25", indicated as 27, remains in its normally co-planar relation to the sidewall segment 25". In such position, the lower sidewall portion 27 serves to aid in maintaining any number of products 20 within the interior 18.

[0055] With reference to FIG. 13 another one of the plurality of 11: opened positions in which the access segment 90 may be positioned is defined when the access segment 90 is folded about the movable connection 92. As such, the access opening 50" is somewhat enlarged from that shown in FIG. 12. However, a portion 27' of the sidewall segment 25" still remains in its normally co-planar position relative to the remainder of the sidewall section 25". This remaining portion 27" is also of sufficient dimension to facilitate the maintenance or containment of any number of products within the hollow interior 18.

[0056] Another feature of the present invention is shown in FIG. 9 wherein at least one of the plurality of movable connections 92 and 94, and preferably the movable connection 94, is structured so as to facilitate detachment of at least a portion of the access segment 90 from the body 12. The detachable portion of the access segment 90 extends between the movable connection 94 and the upper peripheral edge of the sidewall segment 25" contiguous to the perimeter of the open top end 34.

[0057] Accordingly, it is emphasized that the access segment 90 may be positioned between a plurality of different opened positions represented in FIGS. 12, 13 and 9. More specifically, when folded about the movable connection 94 the access segment 90 is in an opened position wherein the access opening 50" has somewhat of a smaller dimension. However, when the access segment 90 is in the opened position demonstrated in FIG. 13 the access opening 50" is

somewhat enlarged from that of FIG. 12. Yet another opened position of the access segment 90 is shown in FIG. 9 wherein it may be completely detached along the movable connection 94.

[0058] In order facilitate such detachment, the movable connection 94 is structure to be separable such as by at least partially if perforating or segmenting the elongated fold line defining the movable connection 94. A similar structure may be utilized to facilitate separation of the corresponding longitudinal peripheral edges of the access segment 90 such as at 96 from the corresponding peripheral edges 96' of the access opening 50".

[0059] By virtue of the above noted structural features of the embodiment of FIGS. 8 through 13, the container assembly 10' is structured to store and transport fragile or other products 20 in a preferred up-right orientation. The laterally directed positioning of such products 20 into and out of the hollow interior 18 through the access opening 50" is also facilitated. However, another feature of this embodiment is the ability to effectively display any contents located within the hollow interior 18 through the access opening 50" by positioning the access segment 90 into anyone of the plurality of opened positions, which are best applicable to the particular circumstances surrounding the use of the container assembly 10". By way of example in certain situations, it may be best to completely detach the access segment 90 from the remainder of the sidewall assembly 16. However, in other circumstances it may be best to position the access segment 90 in either one of the plurality of opened positions shown in FIGS. 12 and 13 so as to display the contents within the hollow interior 18 and at a later time completely enclose the contents by virtue of repositioning the access segment 90 back into the closed position as shown in FIG. 11.

[0060] Regardless of the specific embodiments utilized, the provision of an access segment 40, 40' or 90 and its selective positioning from a closed to an opened position, thereby clearly facilitates the visual access of the hollow interior 18 and any products 20 contained therein. More importantly, physical positioning of the products 20 through the access opening 50, 50' or 50", in a manner which eliminates or significantly reduces the possibility of damage being done thereto is made possible, during the loading and un-loading procedure. More specifically, as demonstrated in FIG. 6, each of the access openings 50, 50' and 50" are sufficiently configured, dimensioned and disposed to facilitate a laterally directed movement or positioning of the product 20 either into the hollow interior 18 or outwardly therefrom as schematically represented by the directional arrows 60. Further, such lateral directed positioning can be accomplished while the product 20 is oriented in a preferred orientation, such as the substantially up-right orientation as also demonstrated in FIG. 6.

[0061] It is emphasized that the product 20 can represent one of a plurality of "bunches" of produce products such as, but not limited to, asparagus. It is universally recognized that when dealing with a produce product such as asparagus, the tips or upper ends thereof, as at 20', are more valued because of an increased flavor and tenderness. However, the asparagus product is extremely fragile and most likely to be physically damaged during the packaging and un-packaging procedure. utilizing conventional techniques, asparagus or

any of the more fragile products represented as 20 are loaded and un-loaded through the open upper end of a conventional container. As such, the products are vertically directed into and out of the container.

[0062] However, because of the unique structural features of the present invention the individual products 20, whether in the form of asparagus or any other product, may be laterally directed, as indicated by directional arrows 60, into and out of the hollow interior 18 through the access opening 50, 50' or 50" when the respective ones of the access segments 40, 40' or 90 are in the opened positioned. As also demonstrated in FIGS. 6, 9, 12, and 13 it may be desirable to display a plurality of products as they are packed within the hollow interior 18 prior to removing the products 20 individually. Therefore, the access segment 40, 40' and 90 when disposed in the opened position, allows clear viewing and thereby facilitates visual access to the hollow interior 18 and more particularly to the products contained therein.

[0063] In order to maintain the access segment 40, 40' or 90 in the closed position the cover assembly 30 includes the one or more flange segments 36 defining the aforementioned retaining portion as best pictured in FIG. 3. The retaining portion or flanges 36 are disposed in overlapping substantially confronting engagement with the exterior surface of the upper ends of the sidewall segments 22, 23, 24 and 25. The exterior surface adjacent the upper end 47 and 47' of the access segments 40 and 40' are also retained by the corresponding portion of the peripheral flange or flanges 36 due to the aforementioned overlapping confronting disposition thereof. In the closed position the cover assembly 40 thereby maintains either of the access segment 40 and 40' in substantially coplanar relation with the correspondingly positioned sidewall segment 25 and 25' as demonstrated in FIG. 3.

[0064] Another structural feature of the present invention is the formation of the body 12 from either a single blank or a plurality of fixedly attached blank segments. The various sidewall segments 22, 23, 24, and 25 are thereby interconnected to one another as shown in FIG. 7 and foldable into the multi-sided configuration of Figures 1 and 5, along normally vertically oriented fold lines 65. Overlapping or mating flaps or portions 67 may be affixed to one another by adhesive or may be integrally formed into a one piece, unitary construction. Also as shown in FIG. 7, the base 14 may be formed by interlocking base segments 69 once being folded relative to an attached, corresponding sidewall segment 23 through 25, along normally horizontally oriented fold lines 71. Engagement of the various base segments 69 may occur by interlocking connecting apertures and tabs as at 73 and 75.

[0065] Yet another structural feature of the present invention is the provision of a plurality of openings or apertures as at 80 formed in adjacent or oppositely spaced apart segments of the sidewall assembly 16. Similarly, a plurality of openings or apertures are formed in the base 14 as at 82 and in the cover assembly 30 as at 84. These openings or apertures are provided to facilitate ventilation of the hollow interior 18 as well as the products or contents 20 contained therein. In addition, when the products or contents 20 are produce or a variety of other products, it may be common practice to pass such products, while contained within the hollow interior 18, through a spray wash or bath for pur-

poses of disinfecting and/or cleaning. Therefore the plurality of apertures, **80**, **82**, **84**, etc. serve to allow fluid flow of both liquid and air through the interior, as well as provide proper drainage or passage of the fluid from the interior and from the products or contents **20** contained therein.

[**0066**] Also a number of other apertures **80'** and **84'** are located in the sidewall assembly **12** and the cover assembly **30** and may be provided to facilitate the aforementioned passage of fluid flow through the hollow interior **18** as well as provide means to handle and/or lift the body **12** with the cover assembly **30** thereon. These apertures or others may be strategically located to also facilitate viewing of the products **20**, to further facilitate display thereof. Naturally, the number, size, configuration and location of the aforementioned apertures may vary and/or be non-existent, depended upon a number of different factors including a type of products or content being maintained within the hollow interior **18**. Also the material from which both the body **12** and the cover assembly **30** is formed may be at least partially liquid impervious or "water proof" so as to resist damage to the material and the integrity of the container assembly **10** and **10'** if subjected to the aforementioned water spray or bath.

[**0067**] Since many modifications, variations and changes in detail can be made to the described preferred embodiment of the invention, it is intended that all matters in the foregoing description and shown in the accompanying drawings be interpreted as illustrative and not in a limiting sense. Thus, the scope of the invention should be determined by the appended claims and their legal equivalents.

[**0068**] Now that the invention has been described,

what is claimed is:

1. A container assembly comprising:
 - a) a body having a hollow interior and including a sidewall assembly disposed in at least partially surrounding relation to said hollow interior,
 - b) a base connected to said sidewall assembly and disposed in covering relation to one end of said hollow interior,
 - c) an access opening formed in said sidewall assembly in communicating relation to said hollow interior,
 - d) an access segment movably connected to said body in spaced relation to said base and disposable between an opened position and a closed position relative to said access opening, and
 - e) said access opening disposed and dimensioned to facilitate visual access of lateral positioning of an object into and out of said hollow interior through said access opening.
2. An assembly as recited in claim 1 further comprising at least one connection disposed on said sidewall assembly in spaced relation to said base, said connection movably interconnecting said access segment to said sidewall assembly.
3. An assembly as recited in claim 2 wherein said connection comprises an elongated fold line pivotally interconnecting said access segment to said sidewall assembly.
4. An assembly as recited in claim 2 wherein said fold line comprises a separable segment structured to movably and removably connect said access segment to said sidewall assembly.

5. An assembly as recited in claim 4 wherein said opened position is defined by said access segment detached from said body along said connection.

6. An assembly as recited in claim 5 wherein said opened position further defines by said access segment pivotally an disposed outwardly from said sidewall assembly along said connection.

7. An assembly as recited in claim 1 further comprising a plurality of connections disposed in spaced relation to one another, each of said connections pivotally interconnecting said access segment to said sidewall assembly.

8. An assembly as recited in claim 7 wherein each of said connections are relatively disposed to vary the size of said access opening when said access segment is in said opened position.

9. An assembly as recited in claim 8 wherein each of said connections are disposed in spaced relation to said base.

10. An assembly as recited in claim 7 wherein at least one of said plurality of connections is structured to removably and movably connect said access segment to said sidewall assembly.

11. An assembly as recited in claim 10 wherein said opened position is defined by said access segment detached from said body along said one connection.

12. An assembly as recited in claim 11 wherein said opened position is further defined by said access segment pivotally disposed outwardly from said sidewall along said one connection.

13. An assembly as recited in claim 12 wherein said open position is further defined by said access segment pivotally disposed outwardly from said sidewall assembly along a second of said plurality of connections.

14. An assembly as recited in claim 13 wherein each of said plurality of connections are relatively disposed to vary the size of said access opening when said access segment is in said opened position.

15. An assembly as recited in claim 14 wherein each of said plurality of connections are disposed in spaced relation to said base.

16. An assembly as recited in claim 15 wherein said closed position is at least partially defined by said access segment disposed in covering relation to said access opening and in substantially co-planar orientation with at least a portion of said sidewall assembly.

17. An assembly as recited in claim 7 wherein said closed position is at least partially defined by said access segment disposed in covering relation to said access opening and co-planar relation with at least a portion of said sidewall assembly.

18. An assembly as recited in claim 7 further comprising a cover assembly movably disposable into and out of covering relation to an open end of said body, said cover assembly disposed in retaining relation to said access segment when said access segment is in said closed position.

19. An assembly as recited in claim 18 wherein said covering assembly comprises a panel and a retaining portion extending outwardly from said panel, said retaining portion comprising a depending flange disposed and substantially overlapping relation and retaining engagement with a peripheral portion of said access segment when in said closed position.

20. A container assembly comprising:

- a) a body having a hollow interior and including a sidewall assembly disposed in at least partially surrounding relation to said hollow interior,
- b) a base connected to said sidewall assembly and disposed in covering relation to one end of said hollow interior,
- c) an access opening formed in said sidewall assembly in communicating relation to said hollow interior,
- d) an access segment correspondingly configured to said access opening and movably connected to said sidewall assembly; said access segment disposable between a closed position relative to said access opening and any of a plurality of opened positions,
- e) a plurality of connections each pivotally interconnecting said access segment to said sidewall assembly and at least one of said connections disposed in spaced relation to said base, and
- f) said access opening disposed and dimensioned to facilitate visual access and lateral positioning of an object into and out of said hollow interior through said access opening.

21. An assembly as recited in claim 20 wherein at least one of said plurality of connections is structured to removably and movably connect said access segment to said sidewall assembly.

22. An assembly as recited in claim 21 wherein at least one of said plurality of opened positions is defined by said access segment detached from said body along said one connection.

23. An assembly as recited in claim 22 wherein at least one of said plurality of opened positions is further defined by said access segment pivotally disposed outwardly from said sidewall assembly along said one connection.

24. An assembly as recited in claim 23 wherein at least one of said plurality of opened position is further defined by said access segment pivotally disposed outwardly from said sidewall assembly along a second of said plurality of connections.

25. An assembly as recited in claim 24 wherein each of said plurality of connections is disposed in spaced relation to one another and to said base.

* * * * *