

(19)



(11)

EP 4 193 876 B1

(12)

EUROPEAN PATENT SPECIFICATION

(45) Date of publication and mention of the grant of the patent:
26.06.2024 Bulletin 2024/26

(51) International Patent Classification (IPC):
A45D 40/04 ^(2006.01) **A45D 40/16** ^(2006.01)
A45D 40/00 ^(2006.01)

(21) Application number: **21213635.2**

(52) Cooperative Patent Classification (CPC):
A45D 40/04; A45D 40/16; A45D 2040/0031;
A45D 2040/0062

(22) Date of filing: **10.12.2021**

(54) LIPSTICK CONTAINER FOR HOT FILLING WITH REPLACEABLE LIPSTICK ASSEMBLY

LIPPENSTIFTBEHÄLTER ZUR HEISSBEFÜLLUNG MIT AUSWECHSELBARER LIPPENSTIFTANORDNUNG

BÂTON DE ROUGE À LÈVRES POUR REMPLISSAGE CHAUD DOTÉ D'UN ENSEMBLE ROUGE À LÈVRES REMPLAÇABLE

(84) Designated Contracting States:
AL AT BE BG CH CY CZ DE DK EE ES FI FR GB GR HR HU IE IS IT LI LT LU LV MC MK MT NL NO PL PT RO RS SE SI SK SM TR

(43) Date of publication of application:
14.06.2023 Bulletin 2023/24

(73) Proprietor: **Zhuhai Ding Rong Plastic Products Co., Ltd**
Zhuhai, Guangdong 519090 (CN)

(72) Inventor: **LIU, Ting Nan**
New Taipei City 221 (TW)

(74) Representative: **Lang, Christian**
LangPatent Anwaltskanzlei IP Law Firm
Ingolstädter Straße 5
80807 München (DE)

(56) References cited:
EP-A1- 3 552 516

EP 4 193 876 B1

Note: Within nine months of the publication of the mention of the grant of the European patent in the European Patent Bulletin, any person may give notice to the European Patent Office of opposition to that patent, in accordance with the Implementing Regulations. Notice of opposition shall not be deemed to have been filed until the opposition fee has been paid. (Art. 99(1) European Patent Convention).

Description

FIELD OF THE INVENTION

[0001] The invention relates to cosmetic containers and more particularly to a lipstick container for hot filling with replaceable lipstick assembly.

BACKGROUND OF THE INVENTION

[0002] Lipsticks are usually made by the following steps. First, hot filling for the lipsticks is poured in molds. Next, when the filling is cooled down forming the lipsticks, the lipsticks are taken out from the molds and placed in lipstick containers. However, if the desired lipsticks are softer or thinner, the lipsticks are tended to break apart easily when filling. Moreover, when the lipsticks are not taken out from the molds or placed in the lipstick containers in a perfect vertical direction, scratches are easily formed on the lipsticks. As a result, taking the lipsticks out of the molds and placing the lipsticks in the lipstick containers are difficult. Besides, the whole lipstick container including the lipstick is disposed after the contained lipstick is consumed. This not only pollutes the environment but also is not eco-friendly.

[0003] Thus, the need for improvement still exists. A lipstick container comprising a base, a lipstick assembly, and a cap, is known from EP 3 552 516 A1.

SUMMARY OF THE INVENTION

[0004] It is therefore one object of the invention to provide a lipstick container for hot filling with replaceable lipstick assembly, as defined in claim 1. The lipstick container of the present invention comprises a base including a close end and an annular trough disposed on an inner surface of an open end distal the close end; a fixed tube including a first axial channel disposed through a center of the fixed tube, an annular groove formed at an inner surface of a first end, an annular flange disposed at an outer surface of the first end, and the annular flange of the fixed tube is secured with the annular trough of the base; a lipstick assembly including a support tube, a sleeving tube and an ascending and descending tube; wherein the support tube includes a second axial channel disposed through a center of the support tube, an annular protrusion formed at an outer surface of a first end of the support tube, internal threads formed at an inner surface of the first end, a plurality of ridges formed on the outer surface and at a middle portion of the support tube, and an annular shoulder disposed between the ridges and the annular protrusion, the fixed tube is put on the support tube, the ridges are mounted on the annular groove; wherein the sleeving tube includes a third axial channel disposed through a center of the sleeving tube, a top of the sleeving tube being flat or inclined, a bottom of the sleeving tube being flat, and at least one locking hole formed through the sleeving tube, the fixed tube is put

on the sleeving tube, the flat bottom of the sleeving tube urges against the annular shoulder of the support tube, the locking hole receives the annular protrusion of the support tube; wherein the ascending and descending tube includes a fourth axial channel disposed through a center of the ascending and descending tube, a recess formed at a first end, a spiral groove portion communicates with the recess and extends from the recess towards a second end distal the recess, and a plurality of longitudinal ribs are formed on an inner surface of the recess, the ascending and descending tube is disposed through the third axial channel of the sleeving tube and through the second axial channel of the support tube, the spiral groove portion is correspondently screwed with the internal threads of the support tube; and a cap including a close end and an open end, wherein the open end of the cap receives the sleeving tube and is secured to the fixed tube.

[0005] A lipstick can be received in the recess and secured by the longitudinal ribs.

[0006] The invention has the following advantages and benefits in comparison with the conventional art:

[0007] The lipstick assembly is replaceable. When the lipstick is consumed, a user can hold the fixed tube and unscrew the support tube to remove the support tube, the sleeving tube and the ascending and descending tube together, and replace a new one. As a result, the base, the fixed tube, and the cover can be reused. This not only protects the environment but also is eco-friendly with reduced waste.

[0008] Suitable for softer and thinner lipstick. The invention is applicable for hot filling the lipstick by placing the lipstick container upwards and downwards. As a result, it is suitable for softer and thinner lipsticks as well. There's no need to fill a lipstick mold first and take the lipstick out later. Thus, there's no need to worry that scratches may be formed easily if the lipstick is not taken out in a perfect vertical direction or the lipstick may easily break apart when filling.

[0009] The above and other objects, features and advantages of the invention will become apparent from the following detailed description taken with the accompanying drawings.

BRIEF DESCRIPTION OF THE DRAWINGS

[0010]

FIG. 1 is a broken away longitudinal sectional view of a lipstick container according to the invention; FIG. 2 is a first exploded view of the lipstick container; FIG. 3 is a second exploded view of the lipstick container; FIG. 4 is a side elevation of the lipstick container; FIG. 5 is a sectional view taken along line 5-5 of FIG. 4
FIG. 6 schematically depicts a premade lipstick and the lipstick assembly.

FIG. 7 schematically depicts the premade lipstick mounted on the lipstick assembly.

FIG. 8 schematically depicts hot filling the lipstick container when placed upwards.

FIG. 9 schematically depicts hot filling the lipstick container when placed upwards is done.

FIG. 10 schematically depicts hot filling the lipstick container when placed downwards.

FIG. 11 schematically depicts hot filling the lipstick container when placed downwards is done.

FIG. 12 schematically depicts a removal of the cap.

FIG. 13 schematically depicts a removal of the base.

FIG. 14 schematically depicts the removal of the lipstick assembly from the fixed tube.

FIG. 15 schematically depicts assembling steps of replacing the new lipstick assembly; and

FIG. 16 is a perspective view of the assembled lipstick container.

DETAILED DESCRIPTION OF THE INVENTION

[0011] Referring to FIG. 1, a lipstick container in accordance with the invention comprises a base 10, a fixed tube 20, a lipstick assembly 60 and a cap 70 as discussed in detail below. The lipstick assembly 60 includes a support tube 30, a sleeving tube 40 and an ascending and descending tube 50. The fixed tube 20 is mounted on the base 10. Next, the support tube 30 is put in the fixed tube 20, so a second end of the support tube 30 urges against the base 10. The sleeving tube 40 is then disposed on a first end of the support tube 30 distal the base 10. Next, the ascending and descending tube 50 is put in the sleeving tube 40 and the support tube 30. Lastly, the cap 70 is put on the sleeving tube 40 and secured to the fixed tube 20.

[0012] Referring to FIG 2, the base 10 includes a close end. The fixed tube 20 includes a first axial channel 21 disposed through a center of the fixed tube 20 and an annular groove 22 is provided at an inner surface of a first end. An annular flange 23 is disposed on an outer surface of the first end. The support tube 30 includes a second axial channel 31 disposed through a center of the support tube 30. External threads 32 disposed on the support tube 30 adjacent the base 10 are screwed with the base 10. The sleeving tube 40 includes a third axial channel 41 disposed through a center of the sleeving tube 40. A top of the sleeving tube 40 being flat or inclined and a bottom of the sleeving tube 40 being flat. The ascending and descending tube 50 includes a fourth axial channel 51 disposed through a center of the ascending and descending tube 50. A recess 52 forms at a first end of the ascending and descending tube 50 and a spiral groove portion 53 extends from the recess 52 towards a second end distal the recess 52. The spiral groove portion 53 communicates with the recess 52. The cap 70 includes an open end. The open end of the cap 70 further includes an annular slot 71 on an inner surface.

[0013] Referring to FIG.3, the base 10 includes an

open end and an annular trough 11 disposed on an inner surface of the open end distal the close end. The base 10 further comprises a projecting member 12 and a slip resistant member 13. The fixed tube 20 further comprises a plurality of stubs 24 on the outer surface distal the annular flange 23. An annular protrusion 33 formed on an outer surface of the support tube 30 distal the external threads 32. Internal threads 34 are formed on an inner surface of the first end of the support tube 30. A plurality of ridges 35 are formed on the outer surface and at a middle portion of the support tube 30. An annular shoulder 36 is disposed between the ridges 35 and the annular protrusion 33. At least one locking hole 42 is formed through the sleeving tube 40. The sleeving tube 40 further comprises an annular protuberance 43 circulated along an inner surface of the sleeving tube 40. A plurality of longitudinal ribs 54 are formed on an inner surface of the recess 52. The cap 70 includes a close end at another end.

[0014] Referring to FIGS. 1 to 3 again, the projecting member 12 is disposed between an outer surface of the slip resistant member 13 and the inner surface of the base 10. The external threads 32 disposed on the support tube 30 adjacent the base 10 are screwed with the projecting member 12 of the base 10. The annular flange 23 of the fixed tube 20 is secured with the annular trough 11 of the base 10. The fixed tube 20 is put on the support tube 30. The ridges 35 are correspondently mounted on annular grooves 22 of the fixed tube 20. The sleeving tube 35 is put in the fixed tube 20. The flat bottom of the sleeving tube 40 urges against the annular shoulder 36 of the support tube 30. The locking hole 42 receives the annular protrusion 33 of the support tube 30. The ascending and descending tube 50 is disposed through the third axial channel 41 of the sleeving tube 40 and then through the second axial channel 31 of the support tube 30. The annular protuberance 43 urges against an end of the recess 52 which is connected to the spiral groove portion 53. The spiral groove portion 53 is correspondently screwed with the internal threads 34 of the support tube 30. The cap 70 is put on the sleeving tube 40 and secured to the fixed tube 20 by the annular slot 71 snapping the stubs 24.

[0015] Referring to FIGS. 4 to 5, the support tube 30 includes three ridges 35 on each side symmetrically disposed on two sides. The annular grooves 22 are disposed on the inner surface of the fixed tube 20 and correspondent to the ridges 35. The ridges 35 are mounted on and secured with the annular grooves 22, so the support tube 30 and the fixed tube 20 are secured.

[0016] Referring to FIGS.6 to 7 and in conjugation with FIGS.1 to 3, a premade lipstick 81 is mounted on the lipstick assembly 60. The premade lipstick 81 is premade by hot filling a mold and then taken out after cooling down. Next, hold and rotate the fixed tube 20. The spiral groove portion 53 of the ascending and descending tube 50 rotates along the internal threads 34 of the support tube 30 towards the top of the sleeving tube 40, such that the

ascending and descending tube 50 rotates towards the top of the sleeving tube 40. The recess 52 of the ascending and descending tube 50 receives the premade lipstick 81 by mounting the premade lipstick 81 onto the longitudinal ribs 54. The hot filling is not limited to only making the premade lipstick 81, and can be applied to other paste.

[0017] Referring to FIGS. 8 to 9 and in conjugation with FIGS. 1 to 3, hot filling the lipstick container when placed upwards is shown. The spiral groove portion 53 of the ascending and descending tube 50 rotates along the internal threads 34 towards a bottom of the support tube 30, such that the ascending and descending tube 50 rotates towards the bottom. Next, a leakage proof member 90 is placed under the support tube 30. Then hot filling is poured into the fourth axial channel 51 of the ascending and descending tube 50 until the hot filling is filled to the top of the sleeving tube 40. When the hot filling is cooled down, the lipstick 80 is made.

[0018] Referring to FIGS. 10 to 11 and in conjugation with FIGS. 1 to 3, hot filling the lipstick container when placed downwards is shown. The spiral groove portion 53 of the ascending and descending tube 50 rotates along the internal threads 34 and towards an opposite direction of the top of the sleeving tube 40, such that the ascending and descending tube 50 rotates towards the bottom. Next, another leakage proof member 90 is placed under the sleeving tube 40. Then hot filling is poured into the fourth axial channel 51 of the ascending and descending tube 50 until the hot filling is filled to the top of the sleeving tube 40. When the hot filling is cooled down, the lipstick 80 is made.

[0019] Referring to FIGS. 12 to 16 and in accordance to FIG 1, steps of replacing the lipstick assembly 60 is shown. When the lipstick 80 is consumed, remove the cap 70 and the base 10. Next, hold the fixed tube 20 to unscrew the support tube 30, and then the support tube 30, the sleeving tube 40 and the ascending and descending tube 50 can be removed to replace the new lipstick assembly 60. The base 10, the fixed tube 20 and the cap 70 can be reused. This not only protects the environment but also is eco-friendly with reduced waste.

Claims

1. A lipstick container for hot filling with replaceable lipstick assembly comprising:

a base (10) including a close end and an annular trough (11) disposed on an inner surface of an open end distal the close end;
 a fixed tube (20) including a first axial channel (21) disposed through a center of the fixed tube, an annular groove (22) formed at an inner surface of a first end, an annular flange (23) disposed on an outer surface of the first end, and the annular flange of the fixed tube secured with

the annular trough of the base;
 a lipstick assembly (60) including a support tube (30), a sleeving tube (40) and an ascending and descending tube (50), wherein the support tube includes a second axial channel (31) disposed through a center of the support tube, an annular protrusion (33) formed at an outer surface of a first end of the support tube, internal threads (34) formed at an inner surface of the first end, a plurality of ridges (35) formed on the outer surface and at a middle portion of the support tube, and an annular shoulder (36) disposed between the ridges and the annular protrusion, the fixed tube is put on the support tube, the ridges are mounted on the annular groove, wherein the sleeving tube includes a third axial channel (41) disposed through a center of the sleeving tube, a top of the sleeving tube being flat or inclined, a bottom of the sleeving tube being flat, and at least one locking hole (42) formed through the sleeving tube, the fixed tube is put on the sleeving tube, the flat bottom of the sleeving tube urges against the annular shoulder of the support tube, the locking hole receives the annular protrusion of the support tube, wherein the ascending and descending tube includes a fourth axial channel (51) disposed through a center of the ascending and descending tube, a recess (52) formed at a first end, a spiral groove portion (53) communicates with the recess and extends from the recess towards a second end distal the recess, and a plurality of longitudinal ribs (54) formed on an inner surface of the recess, the ascending and descending tube is disposed through the third axial channel of the sleeving tube and through the second axial channel of the support tube, the spiral groove portion is correspondently screwed with the internal threads of the support tube; and
 a cap (70) including a close end and an open end,
 wherein the open end of the cap receives the sleeving tube and is secured to the fixed tube.

2. The lipstick container of claim 1, wherein the base further comprising a slip resistant member (13) and a projecting member (12), the projecting member disposed between an outer surface of the slip resistant member and the inner surface of the base, external threads (32) disposed on the support tube adjacent the base are screwed with the projecting member of the base.
3. The lipstick container of claim 1, wherein the sleeving tube further comprising an annular protuberance (43) circulated along an inner surface of the sleeving tube, the annular protuberance urging against an end of the recess connected to the spiral groove por-

tion.

4. The lipstick container of claim 1, wherein the ascending and descending tube further comprising a lipstick (81) received in the recess and secured by the longitudinal ribs. 5
5. The lipstick container of claim 1, wherein the fixed tube further comprising a plurality of stubs (24) on the outer surface distal the annular flange, and the cap further comprising an annular slot (71) in an inner surface of the open end, the cap being put on the sleeving tube and secured to the fixed tube by the annular slot snapping the stubs. 10 15

Patentansprüche

1. Lippenstiftbehälter zum Heißbefüllen mit einer austauschbaren Lippenstiftanordnung, umfassend: 20

eine Basis (10) mit einem geschlossenen Ende und einer ringförmigen Rinne (11), die an einer Innenfläche eines offenen Endes distal zum geschlossenen Ende angeordnet ist; 25

ein feststehendes Rohr (20) mit einem ersten axialen Kanal (21), der durch eine Mitte des feststehenden Rohrs angeordnet ist, einer ringförmigen Nut (22), die an einer Innenfläche eines ersten Endes ausgebildet ist, einem ringförmigen Flansch (23), der an einer Außenfläche des ersten Endes angeordnet ist, und wobei der ringförmige Flansch des feststehenden Rohrs mit der ringförmigen Rinne der Basis befestigt ist; 30

eine Lippenstiftanordnung (60), die ein Stützrohr (30), ein Mantelrohr (40) und ein aufsteigendes und absteigendes Rohr (50) umfasst, wobei das Stützrohr einen zweiten axialen Kanal (31), der durch eine Mitte des Stützrohrs angeordnet ist, einen ringförmigen Vorsprung (33), der an einer Außenfläche eines ersten Endes des Stützrohrs ausgebildet ist, ein Innengewinde (34), das an einer Innenfläche des ersten Endes ausgebildet ist, und eine Vielzahl von Rippen (35), die an der Außenfläche und an einem mittleren Abschnitt des Stützrohrs ausgebildet sind, und eine ringförmige Schulter (36), die zwischen den Rippen und dem ringförmigen Vorsprung angeordnet ist umfasst, wobei das feststehende Rohr auf das Stützrohr aufgesetzt ist, die Rippen an der ringförmigen Nut angebracht sind, wobei das Mantelrohr einen dritten axialen Kanal (41) aufweist, der durch eine Mitte des Mantelrohrs angeordnet ist, wobei eine Oberseite des Mantelrohrs flach oder geneigt ist, eine Unterseite des Mantelrohrs flach ist, und mindestens ein Verriegelungsloch (42), das durch das Mantelrohr hindurch ausgebildet ist, das 35 40 45 50 55

feststehende Rohr auf das Mantelrohr aufgesetzt wird, die flache Unterseite des Mantelrohrs gegen die ringförmige Schulter des Stützrohrs drückt, das Verriegelungsloch den ringförmigen Vorsprung des Stützrohrs aufnimmt, wobei das aufsteigende und absteigende Rohr einen vierten axialen Kanal (51), der durch eine Mitte des aufsteigenden und absteigenden Rohrs hindurch angeordnet ist, eine Ausnehmung (52), die an einem ersten Ende ausgebildet ist, und einen spiralförmigen Rillenabschnitt (53), der mit der Aussparung in Verbindung steht und sich von der Aussparung zu einem zweiten, distalen Ende der Aussparung erstreckt, und eine Vielzahl von Längsrippen (54), die auf einer Innenfläche der Aussparung ausgebildet sind, enthält, wobei das aufsteigende und absteigende Rohr durch den dritten axialen Kanal des Mantelrohrs und durch den zweiten axialen Kanal des Stützrohrs angeordnet ist, wobei der spiralförmige Rillenabschnitt entsprechend mit den Innengewinden des Stützrohrs verschraubt ist; und eine Kappe (70), die ein geschlossenes Ende und ein offenes Ende aufweist, wobei das offene Ende der Kappe das Mantelrohr aufnimmt und an dem feststehenden Rohr befestigt ist.

2. Lippenstiftbehälter nach Anspruch 1, wobei die Basis ferner ein rutschfestes Element (13) und ein vorstehendes Element (12) umfasst, wobei das vorstehende Element zwischen einer Außenfläche des rutschfesten Elements und der Innenfläche der Basis angeordnet ist, wobei Außengewinde (32), die auf dem Stützrohr angrenzend an die Basis angeordnet sind, mit dem vorstehenden Element der Basis verschraubt sind. 30 35
3. Lippenstiftbehälter nach Anspruch 1, wobei das Mantelrohr ferner einen ringförmigen Vorsprung (43) aufweist, der entlang einer Innenfläche des Mantelrohrs umläuft, wobei der ringförmige Vorsprung gegen ein Ende der mit dem spiralförmigen Rillenabschnitt verbundenen Aussparung drückt. 40 45
4. Lippenstiftbehälter nach Anspruch 1, wobei das aufsteigende und absteigende Rohr ferner einen Lippenstift (81) umfasst, der in der Aussparung aufgenommen und durch die Längsrippen befestigt ist. 50
5. Lippenstiftbehälter nach Anspruch 1, wobei das feststehende Rohr ferner eine Vielzahl von Stümpfen (24) auf der äußeren Oberfläche distal des ringförmigen Flansches aufweist und die Kappe ferner einen ringförmigen Schlitz (71) in einer inneren Oberfläche des offenen Endes aufweist, wobei die Kappe auf das Mantelrohr aufgesetzt und an dem feststehenden Rohr durch den ringförmigen Schlitz befestigt ist. 55

tigt wird, der die Stümpfe einschnappt.

Revendications

1. Contenant de rouge à lèvres pour le remplissage à chaud avec un ensemble de rouge à lèvres remplaçable comprenant :

une base (10) incluant une extrémité fermée et un creux annulaire (11) disposé sur une surface intérieure d'une extrémité ouverte distale de l'extrémité fermée ; un tube fixe (20) incluant un premier canal axial (21) disposé à travers un centre du tube fixe, une rainure annulaire (22) formée au niveau d'une surface intérieure d'une première extrémité, une bride annulaire (23) disposée sur une surface extérieure de la première extrémité, et la bride annulaire du tube fixe étant fixée au creux annulaire de la base ;

un ensemble de rouge à lèvres (60) incluant un tube de support (30), un tube de manchonnage (40) et un tube ascendant et descendant (50), dans lequel le tube de support inclut un deuxième canal axial (31) disposé à travers un centre du tube de support, une saillie annulaire (33) formée au niveau d'une surface extérieure d'une première extrémité du tube de support, des filets internes (34) formés au niveau d'une surface intérieure de la première extrémité, une pluralité de nervures (35) formées sur la surface extérieure et au niveau d'une portion médiane du tube de support, et un épaulement annulaire (36) disposé entre les nervures et la saillie annulaire, le tube fixe est placé sur le tube de support, les nervures sont montées sur la rainure annulaire,

dans lequel le tube de manchonnage inclut un troisième canal axial (41) disposé à travers un centre du tube de manchonnage, un dessus du tube de manchonnage étant plat ou incliné, un dessous du tube de manchonnage étant plat, et au moins un trou de verrouillage (42) formé à travers le tube de manchonnage, le tube fixe est placé sur le tube de manchonnage, le dessous plat du tube de manchonnage pousse contre l'épaulement annulaire du tube de support, le trou de verrouillage reçoit la saillie annulaire du tube de support,

dans lequel le tube ascendant et descendant inclut un quatrième canal axial (51) disposé à travers un centre du tube ascendant et descendant, un évidement (52) formé à une première extrémité, une portion de rainure spiralée (53) communique avec l'évidement et s'étend depuis l'évidement vers une seconde extrémité distale de l'évidement, et une pluralité de nervures longitudinales (54) formées sur une surface inté-

rieure de l'évidement, le tube ascendant et descendant est disposé à travers le troisième canal axial du tube de manchonnage et à travers le deuxième canal axial du tube de support, la portion de rainure spiralée est vissée de manière correspondante aux filets internes du tube de support ; et

un capuchon (70) incluant une extrémité fermée et une extrémité ouverte, dans lequel l'extrémité ouverte du capuchon reçoit le tube de manchonnage et est fixée au tube fixe.

2. Contenant de rouge à lèvres selon la revendication 1, dans lequel la base comprend en outre un élément résistant au glissement (13) et un élément de projection (12), l'élément de projection étant disposé entre une surface extérieure de l'élément résistant au glissement et la surface intérieure de la base, des filets externes (32) disposés sur le tube de support adjacent à la base sont vissés à l'élément de projection de la base.

3. Contenant de rouge à lèvres selon la revendication 1, dans lequel le tube de manchonnage comprend en outre une protubérance (43) annulaire mise en circulation le long d'une surface intérieure du tube de manchonnage, la protubérance annulaire poussant contre une extrémité de l'évidement relié à la portion de rainure spiralée.

4. Contenant de rouge à lèvres selon la revendication 1, dans lequel le tube ascendant et descendant comprenant en outre un rouge à lèvres (81) reçu dans l'évidement et fixé par les nervures longitudinales.

5. Contenant de rouge à lèvres selon la revendication 1, dans lequel le tube fixe comprend en outre une pluralité de talons (24) sur la surface extérieure distale de la bride annulaire, et le capuchon comprend en outre une fente annulaire (71) dans une surface intérieure de l'extrémité ouverte, le capuchon étant placé sur le tube de manchonnage et fixé au tube fixe par la fente annulaire encliquetant les talons.

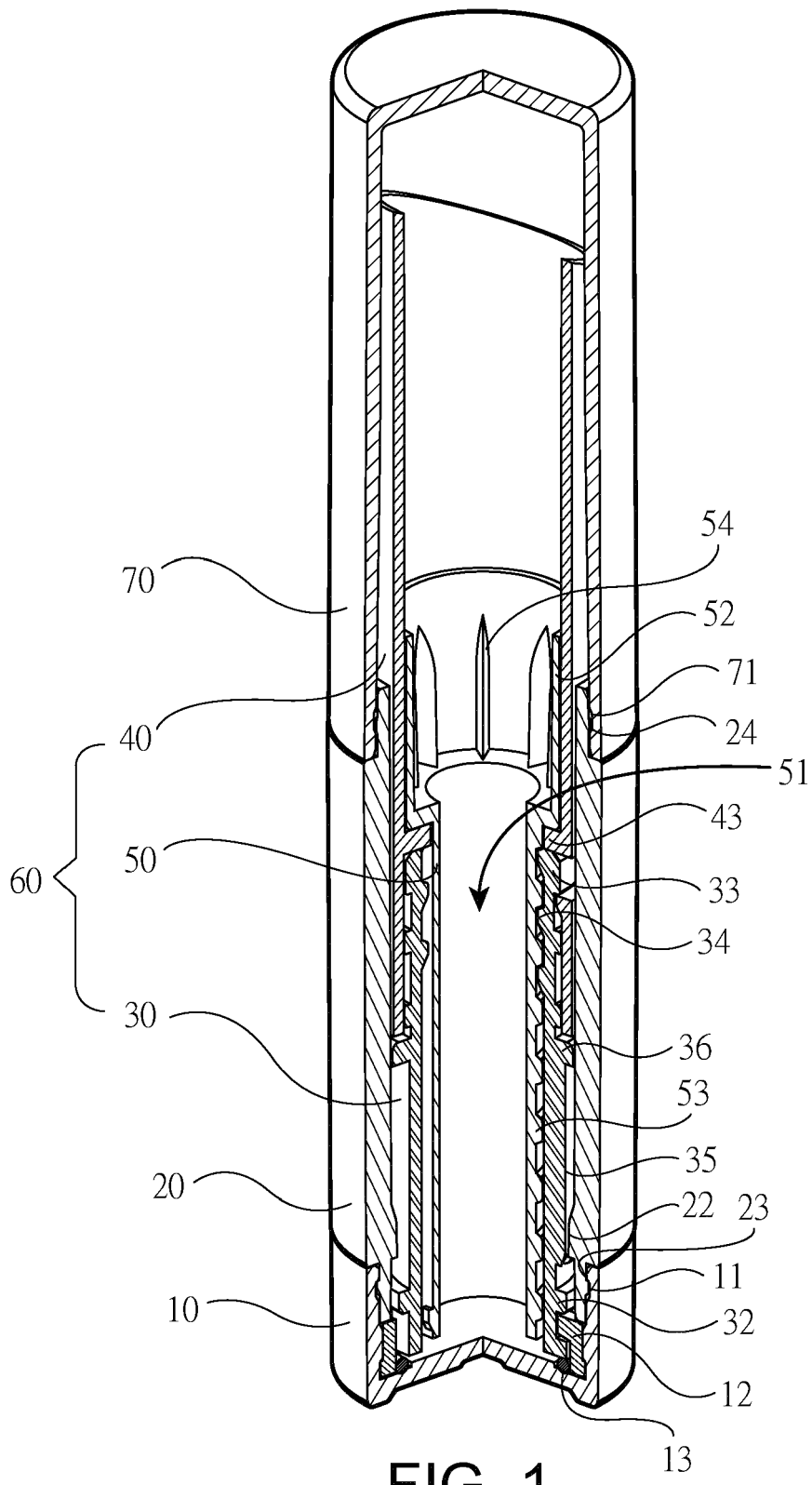

FIG. 1

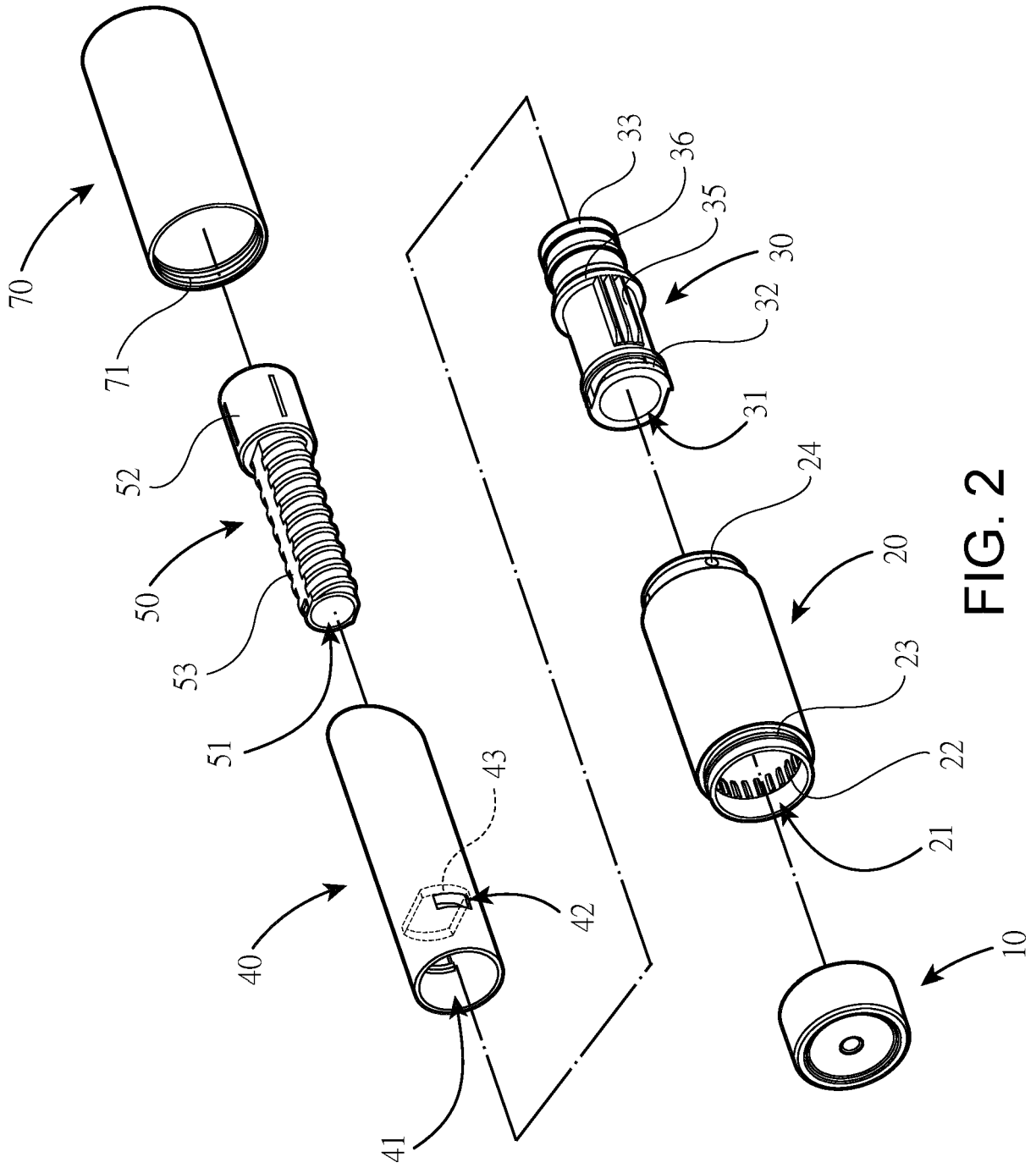

FIG. 2

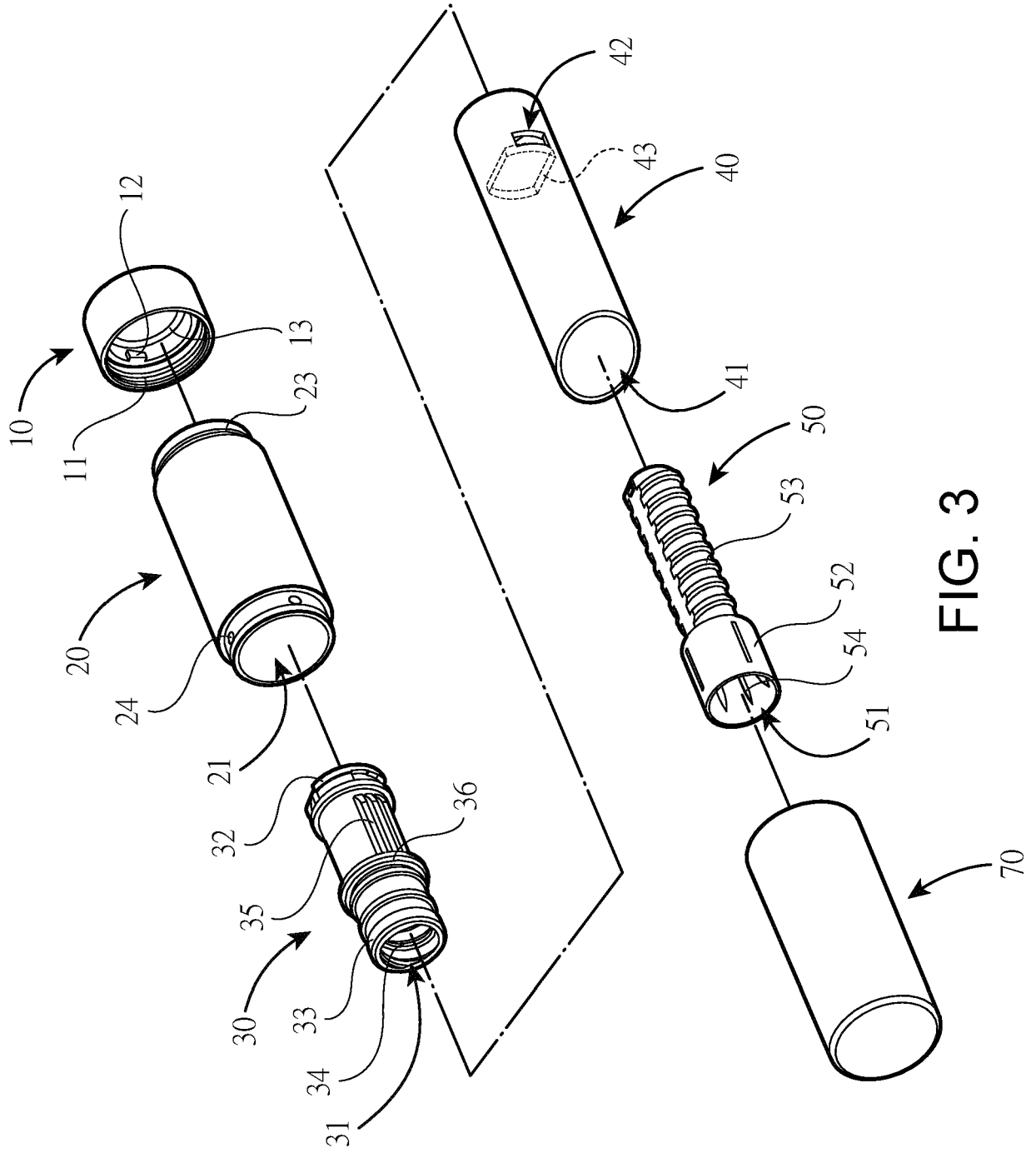

FIG. 3

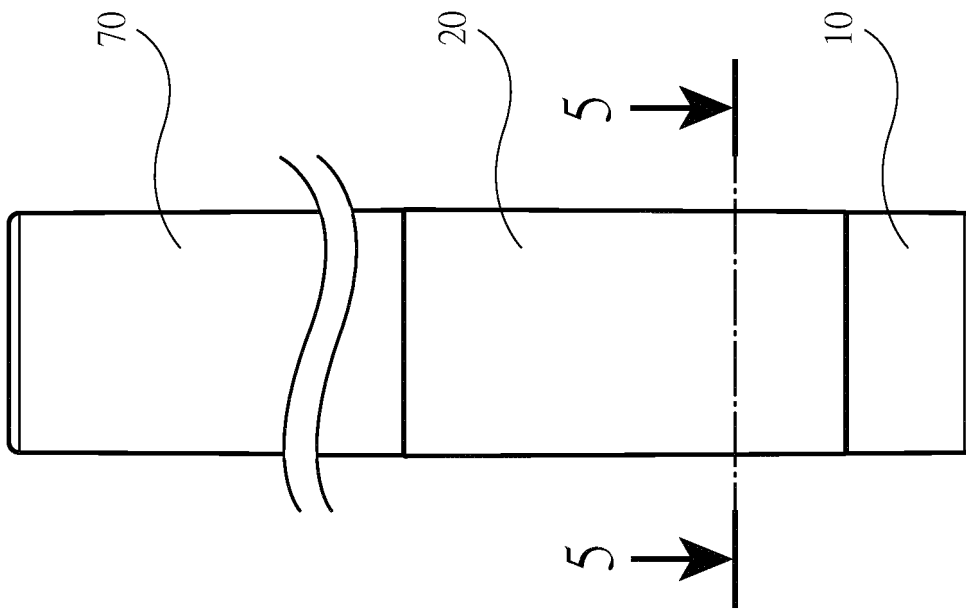

FIG. 4

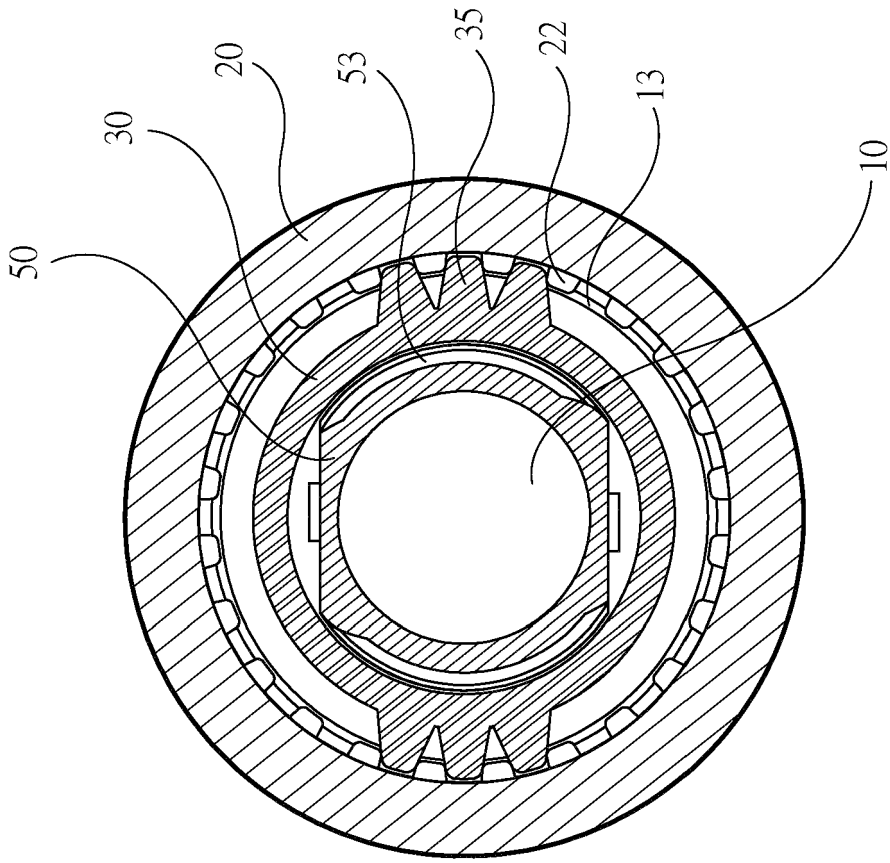

FIG. 5

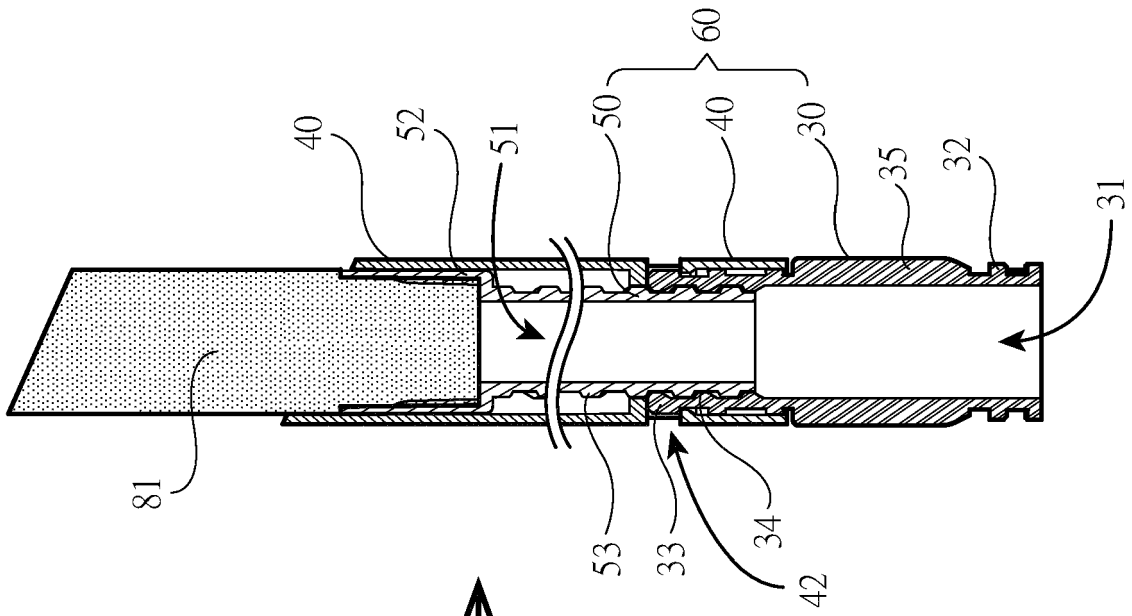

FIG. 7

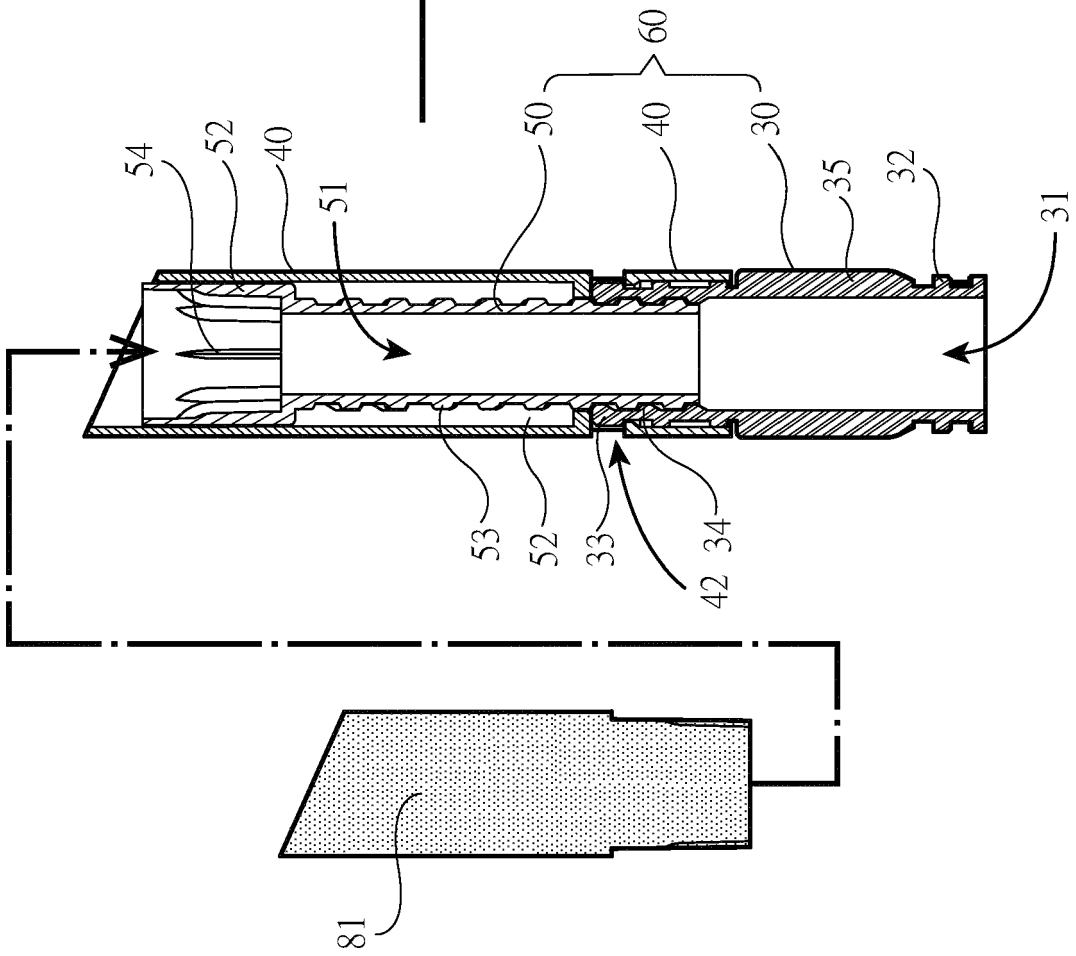

FIG. 6

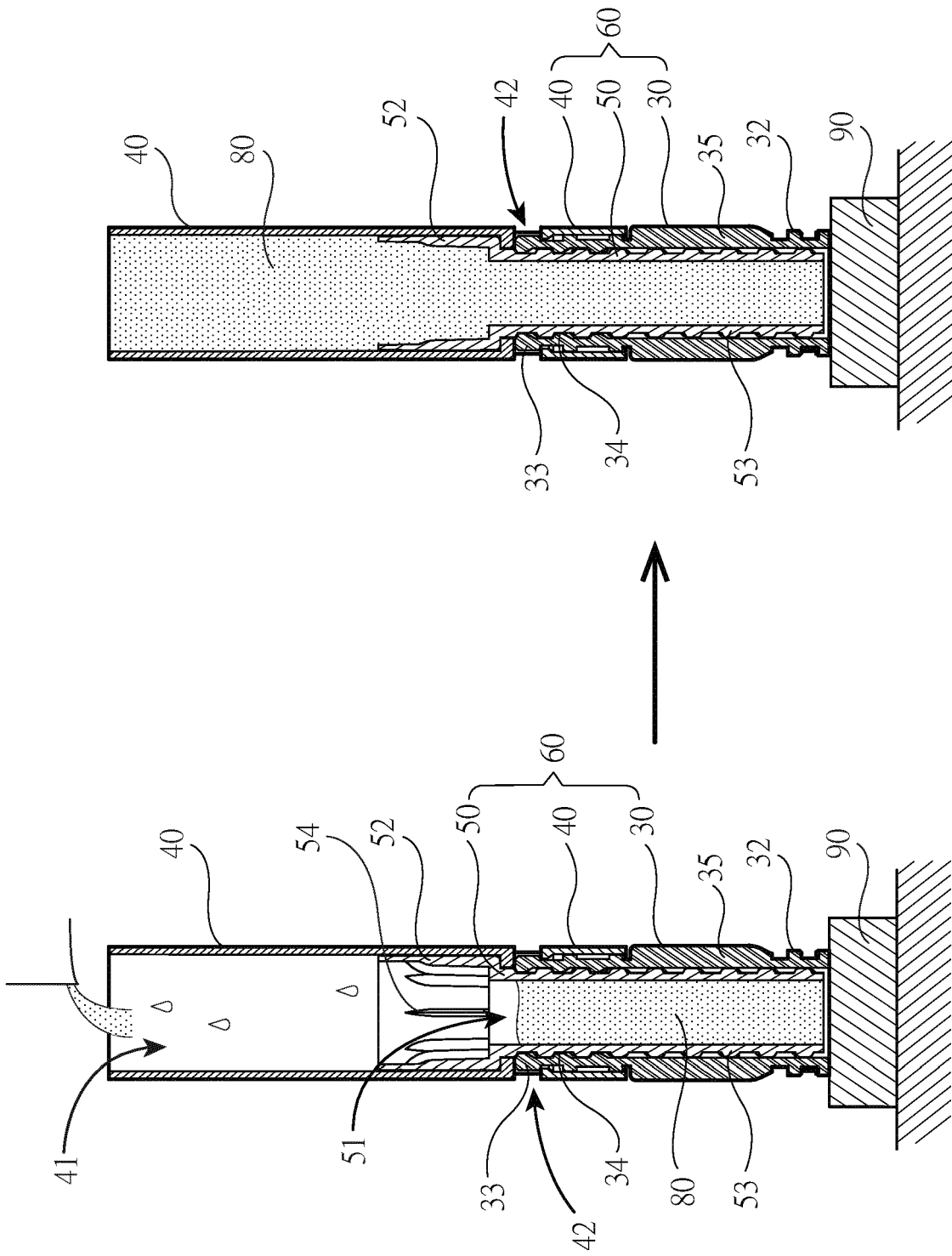

FIG. 9

FIG. 8

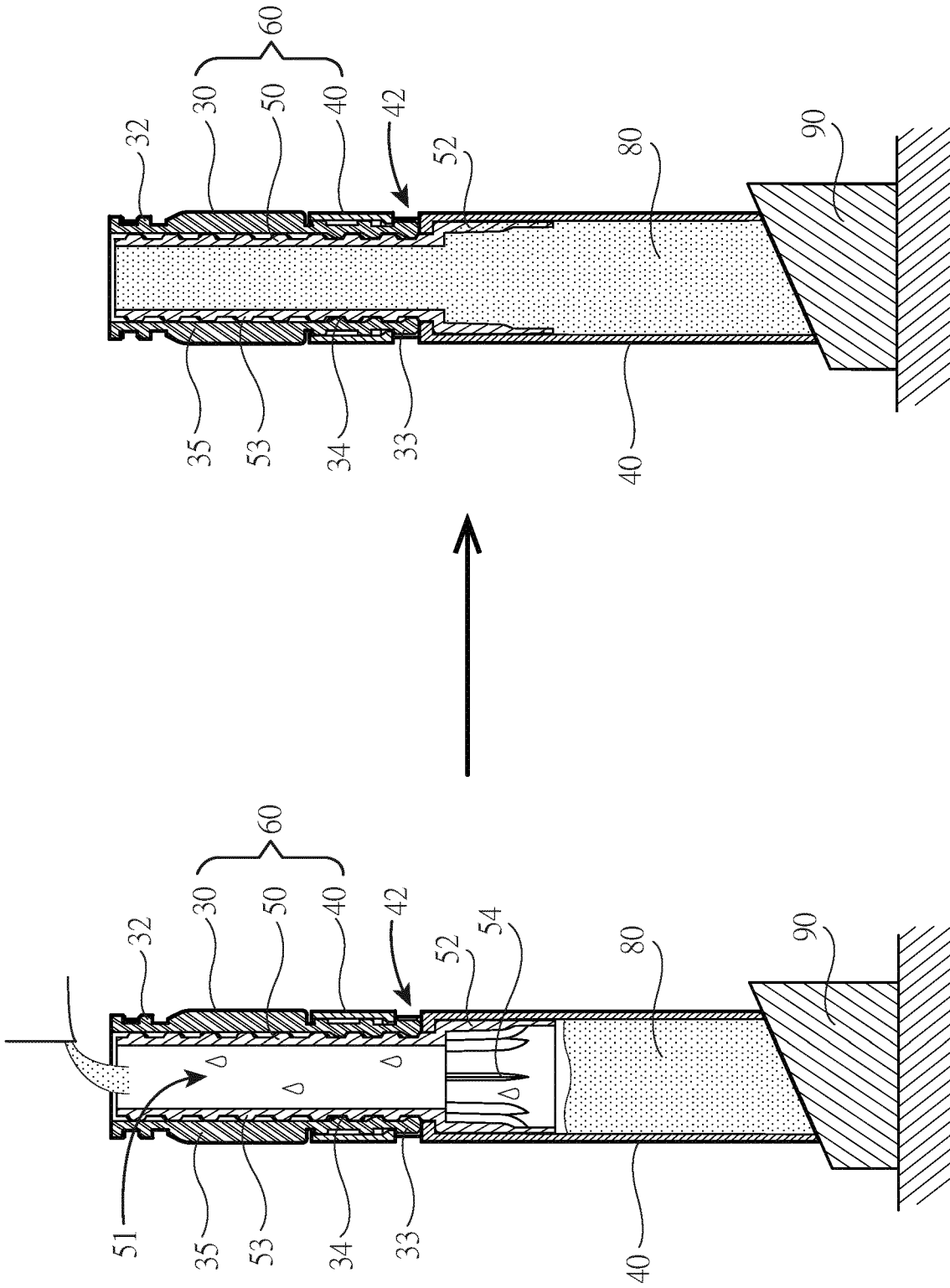

FIG. 11

FIG. 10

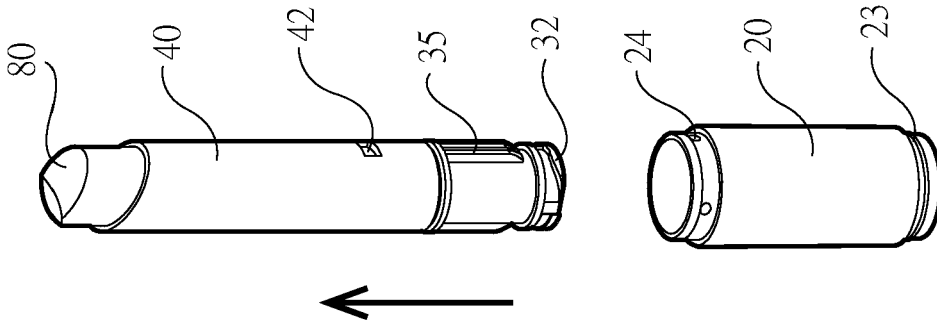

FIG. 14

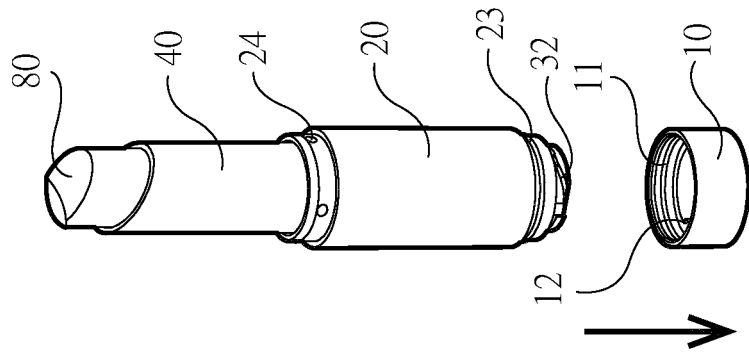

FIG. 13

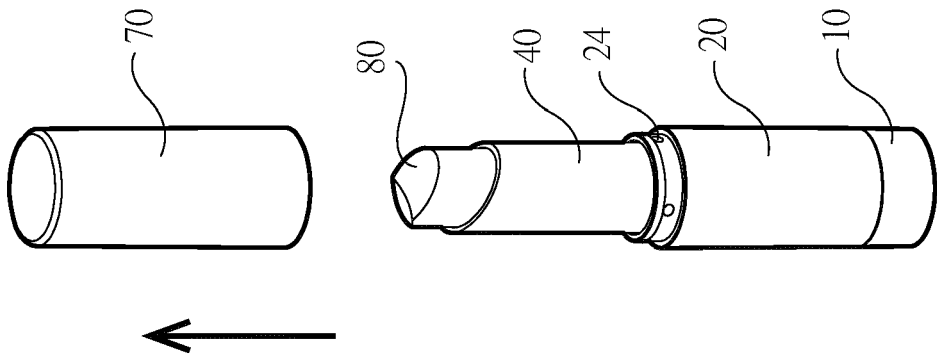

FIG. 12

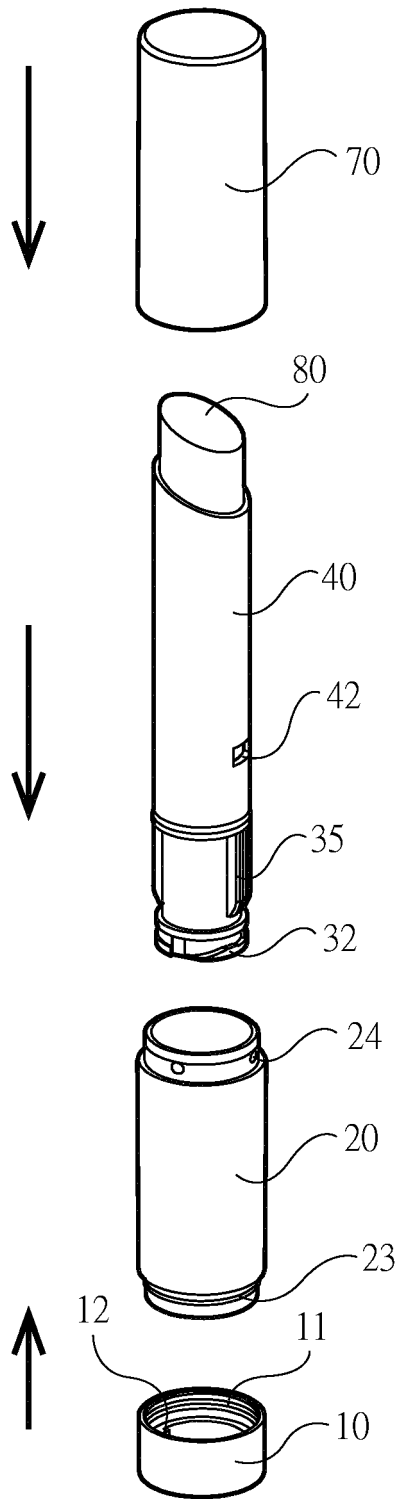

FIG. 15

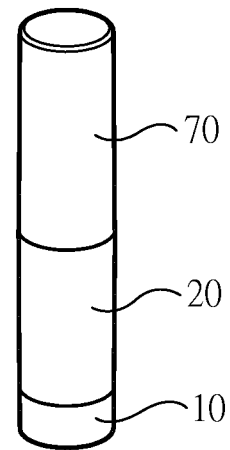

FIG. 16

REFERENCES CITED IN THE DESCRIPTION

This list of references cited by the applicant is for the reader's convenience only. It does not form part of the European patent document. Even though great care has been taken in compiling the references, errors or omissions cannot be excluded and the EPO disclaims all liability in this regard.

Patent documents cited in the description

- EP 3552516 A1 [0003]