

W. READ.  
Water-Wheel.

No. 207,894. *Fig. 1.* Patented Sept. 10, 1878.

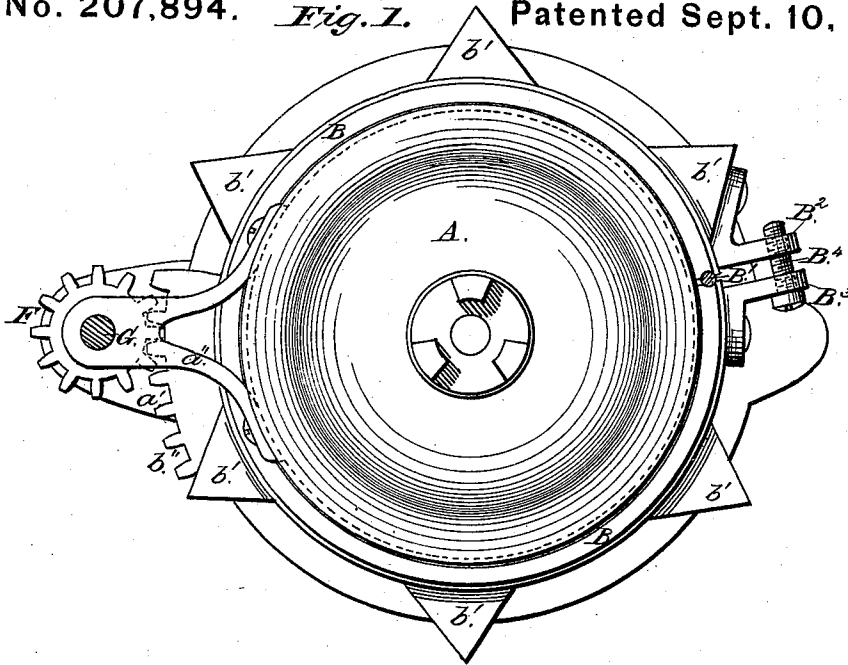

*Fig. 2.*

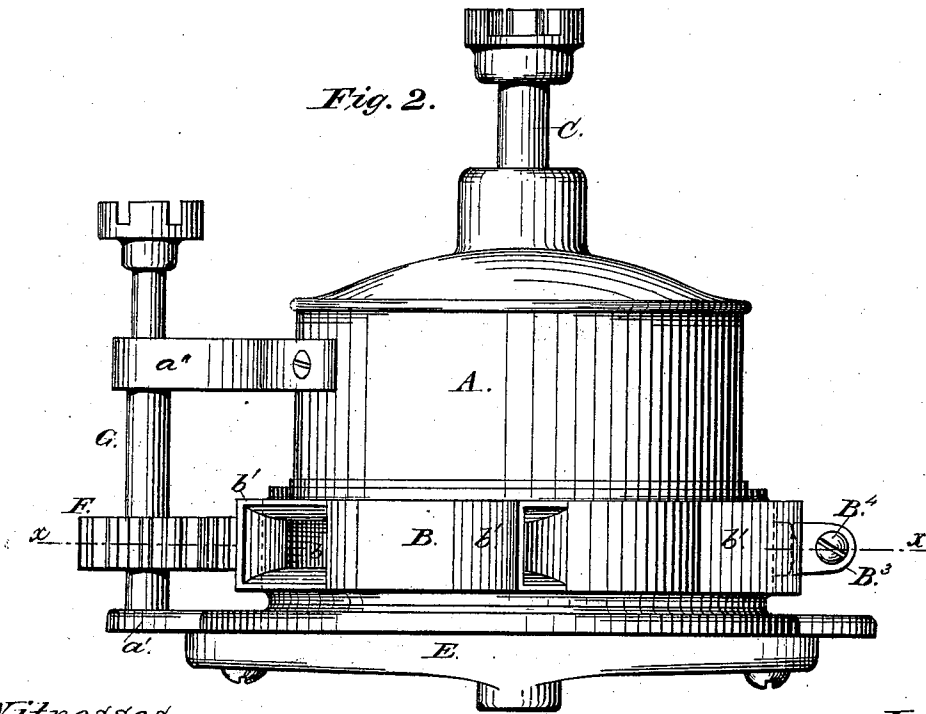

Witnesses:

W. T. Cowd.  
Levi Bacon.

Inventor:

Willis Read.

W. READ.  
Water-Wheel.

No. 207,894.

Fig. 3. Patented Sept. 10. 1878.

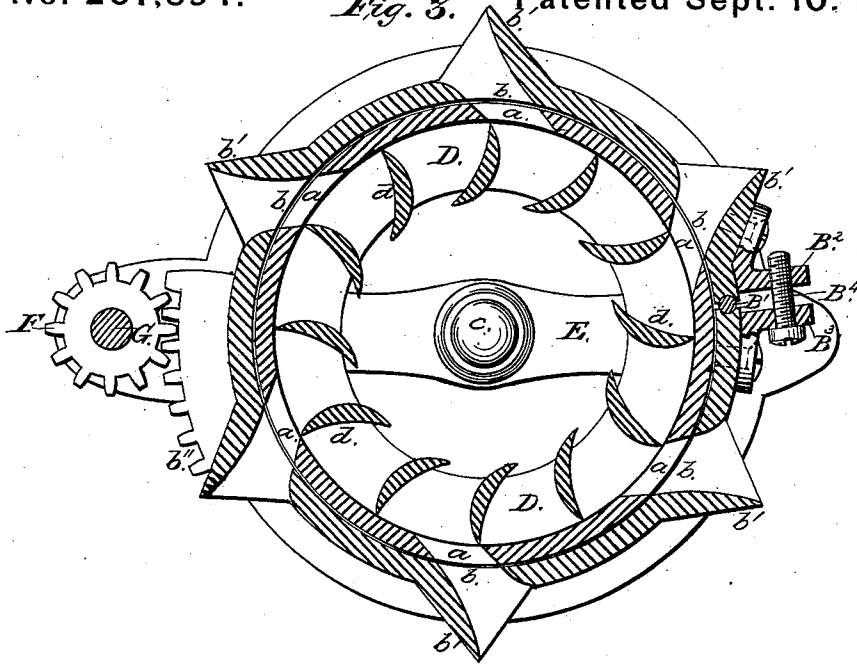

Fig. 4.

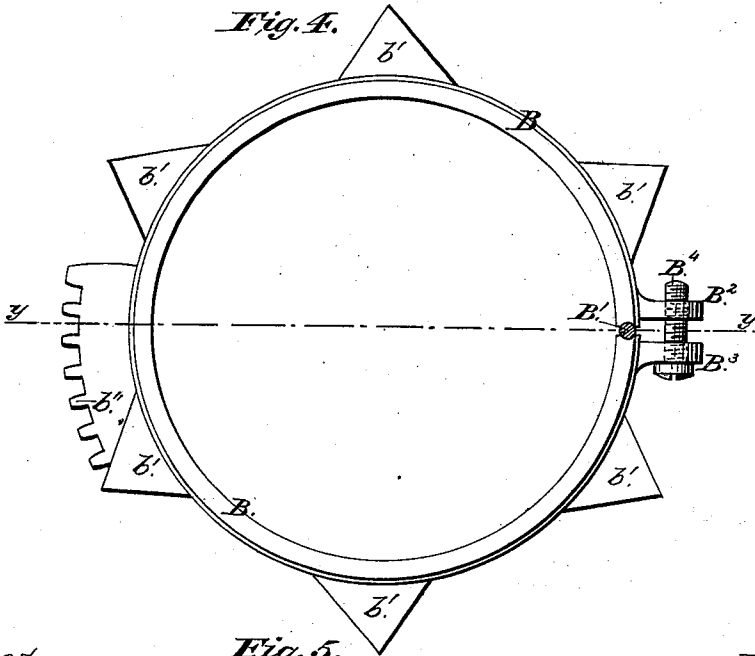
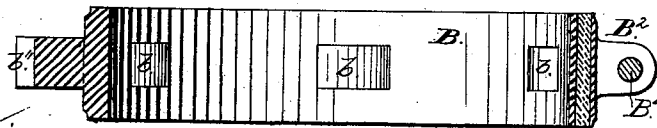

Fig. 5.



Witnesses:

W. P. Cowl.  
Levi Bacon.

Inventor:

W. Read.

# UNITED STATES PATENT OFFICE.

WILLIS READ, OF DANBURY, CONNECTICUT.

## IMPROVEMENT IN WATER-WHEELS.

Specification forming part of Letters Patent No. **207,894**, dated September 10, 1878; application filed March 4, 1878.

*To all whom it may concern:*

Be it known that I, WILLIS READ, of Danbury, in the county of Fairfield and State of Connecticut, have invented certain new and useful Improvements in Water-Wheels; and I do hereby declare that the following is a full, clear, and exact description thereof, which will enable others skilled in the art to which it appertains to make and use the same, reference being had to the accompanying drawings, and to letters of reference marked thereon, which form a part of this specification.

My invention relates to water-wheels, and the object is to improve the water-wheel, its case, and gate, so that the gate can be adjusted when desired and when worn; and it consists in an improvement of the water-wheel for which Letters Patent of the United States were granted to me the 21st day of November, 1871, and numbered 121,195.

In the accompanying drawing, Figure 1 is a plan view of my water-wheel. Fig. 2 is a side elevation of the same. Fig. 3 is a horizontal section on line *xx* of Fig. 2. Fig. 4 is a plan view of the annular gate. Fig. 5 is a vertical section on line *yy* of Fig. 4.

In the drawing, A is a cylindrical case, which is placed in the fore-bay in the ordinary manner, and is provided with a series of openings, *a a*. B is an annular gate or cylinder, cut at one side and surrounding the case A, and fitting thereto sufficiently tight to stop the water at its top or lower edge, and has as many openings *b* through it as there are openings *a* in the case, and they are of the same size and coincident therewith.

The gate B is of peculiar construction, it being cut at one side, and is there recessed for the reception of the packing B<sup>1</sup>, made of rubber, lead, soft wood, or other suitable material. On each side of the cut are secured two brackets, B<sup>2</sup> and B<sup>3</sup>, through which a bolt or screw, B<sup>4</sup>, passes, and by it the gate B can be adjusted as it wears on its inner side. The brackets may, however, be cast on the gate, as shown in Figs. 4 and 5, if desired. The gate B may be revolved on case A far enough to move the openings *b* away from the openings *a* in the case A, or, in other words, to completely cut off the flow of water through the openings.

Over and about the openings *b* of the gate B are the projecting chutes *b'*, having the proper shape to direct the inflowing water through the gate and into the case A.

C is the upright shaft, resting on the center *c* at its lower end, and has the wheel D secured to it in proper position. The wheel D is provided with a number of vertical buckets, *d*, placed at the periphery, and secured between the two heads of the wheel. The buckets *d* are concave on their inner vertical face, and are placed at an angle, and the upper head of the wheel is entire or whole, only admitting the shaft, while the lower head is open within the buckets *d*.

The bridge-tree E supports the wheel D and shaft C on the conical center *c*, upon which it revolves.

The annular gate B is provided on one side with a number of teeth, *b''*, into which a pinion, F, on the shaft G meshes. This shaft is supported on a bracket, *a'*, below, and *a''* above, and by it and the pinion E the gate B is revolved to open and close the openings.

The wheel, its case, chutes, and gate being constructed as described, and being placed within the fore-bay, the water is let on by turning the shaft G and pinion F, and thus revolving the gate B far enough to open or partially open the openings, as desired, for the amount of work required.

The advantages of my wheel are, that the gate can be easily and nicely adjusted as it becomes worn, and the gate and packing can also be easily replaced or repaired by being cut at one side only. It also becomes springy, and will readily expand when loosened from the bolt. It is simple in design, easy of construction, as are also the gate, chutes, and the means of operating them, and none of them are liable to get out of order.

Having thus described my invention, what I claim, and desire to secure by Letters Patent, is—

1. The combination of the wheel D, having buckets *d*, with the case A, having openings *a*, annular gate B, cut at one side, with openings *b* and projecting chutes *b'*, all constructed and arranged as shown, and for the purpose described.

2. In a water-wheel, the annular adjustable

gate B, cut at one side and provided with packing B<sup>1</sup>, brackets B<sup>2</sup> B<sup>3</sup>, and bolt or screw B<sup>4</sup>, and teeth b'', in combination with the case A, wheel D, and pinion F, all constructed and arranged as shown, and for the purpose specified.

In testimony that I claim the foregoing as

my own I affix my signature in presence of two witnesses.

WILLIS READ.

Witnesses:

W. P. COWL,  
LEVI BACON.